

Mechanical Structure for FST

21 January 2021 @ F2F Meeting

Yi Yang, Te-Chuan Huang,
Chan-Jui Feng, Cheng-Wei Lin,
Chun-Wei Su, Han-Sheng Li (Purdue),
Pu-Kai Wang (Paris), Yu-Shan Chang (Purdue),

Department of Physics, NCKU

Chung-De Chen, Pei-Chia Chung,
Bing-Teng Hong, Tsai-Hsuan Hsieh,
Jian-Yu Wang, Tian-Shiang Yang

Department of Mechanical Engineering,
NCKU

Tang-Shiang Chang, Ming-Tang Dong,
Yuan-Ruey Chuang, Yean Ho Liao

Aerospace Industrial
Development Corporation



The Forward Silicon Tracker

Flexible hybrid PCB: **SDU/IU**

Inner Signal Cable: **BNL/IU**

T-Board: **SDU/IU**

APV25 Chip: **UIC**

Mechanical Structure
(+ cooling pipe): **NCKU/AIDC**

Silicon sensor: **UIC/BNL**

Supporting Structure &
Integration: **BNL**

Cooling: **BNL/NCKU**

Simulation: **UIC/BNL/IISER/NCKU**

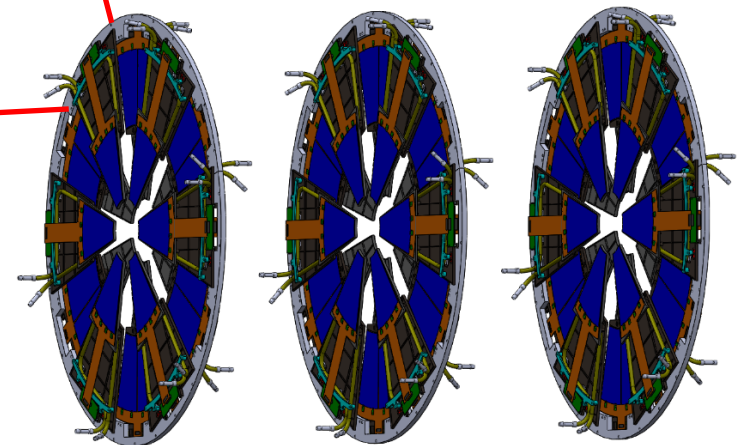



Design of Mechanical Structure

Main structure:

- ❑ Material: PEEK
- ❑ Thermal Conductivity: 0.24 W/m/K
- ❑ ES&H: **Good**
- ❑ Rad.: **Good**

Tube fixture:

- ❑ Material: PEEK
- ❑ ES&H: **Good**
- ❑ Rad.: **Good**

Thermal grease:

- ❑ Material: Thermalrigh TF8 2G
- ❑ ES&H: **Good**
- ❑ Rad.: **Good**

Glue (inner MS+outer MS):

- ❑ Material: Loctite EA 9359.3 AERO
- ❑ ES&H: **Good**
- ❑ Rad.: **Good**

Glue (hybrid+MS):

- ❑ Material: Araldite 2011
- ❑ ES&H: **Good**
- ❑ Rad.: **Good**

Heat sink:

- ❑ Material: Al 6061
- ❑ Size: $\sim 8.2 \times 8.0 \times 3 \text{ mm}^2$
- ❑ ES&H: **Good**
- ❑ Rad.: **Good**

Tube:

- ❑ Material: Stainless 316
- ❑ Size: OD 6.35 mm, ID 5.54 mm
- ❑ Thermal Conductivity: 14 W/m/K
- ❑ ES&H: **Good**
- ❑ Rad.: **Good**

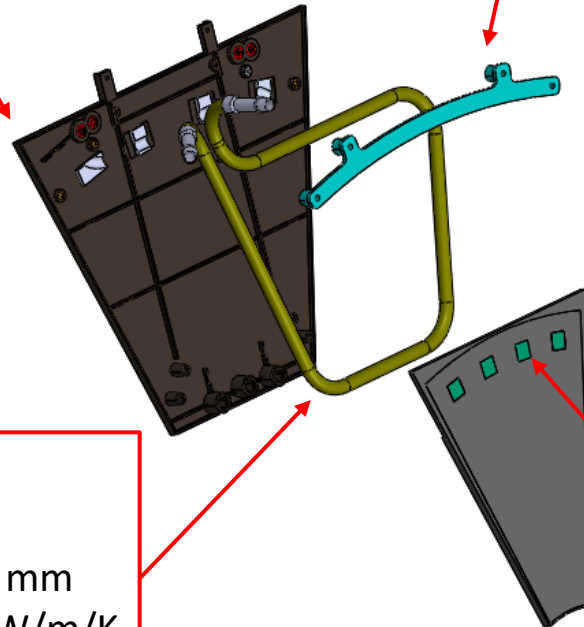

*PEEK has been used in collider experiments: e.g. STAR HFT

Manufacture of Cooling Tube

- 1) Passivation treatment on the raw 316 stainless steel tube
- 2) Use Tube Bending Die (TBD) to bend the tube
- 3) Use 3D printed Miscellaneous Service Tool (MST) to check the dimensions.
- 4) Braze the connectors to the tube
- 5) Leakage test
- 6) Clean the cooling tube

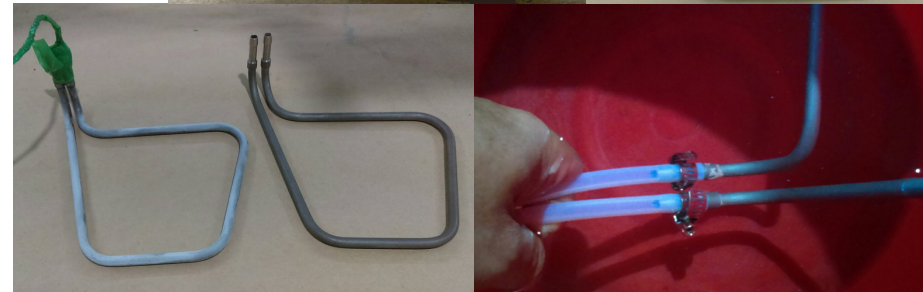
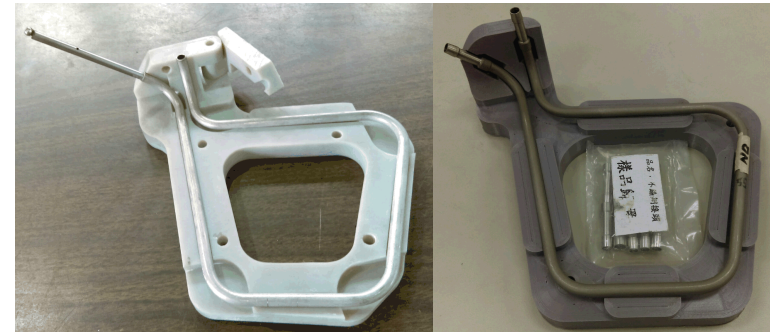
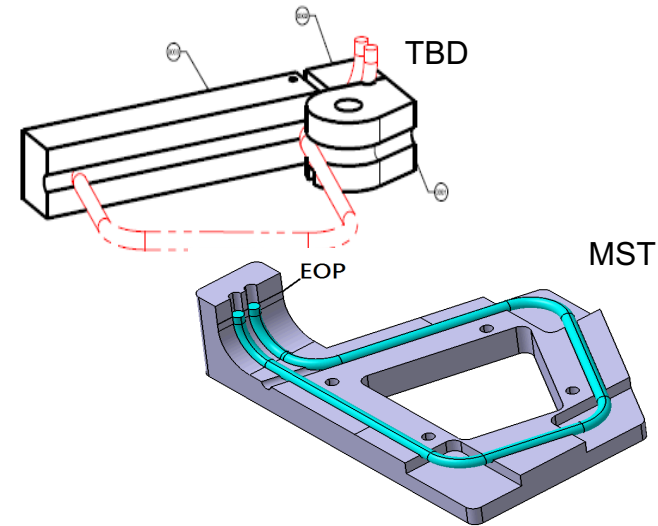

Injection Molding for MS

- ❑ The mechanical structure are made using injection molding method
- ❑ Very challenging: thin + large + complex structure
many components embedded

Moving Half (Core Side)

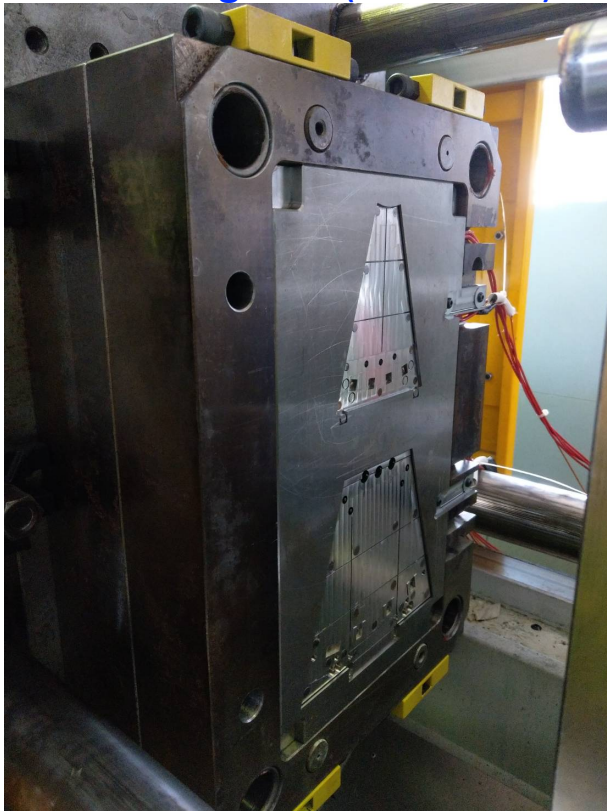

Fixed Half (Cavity Side)

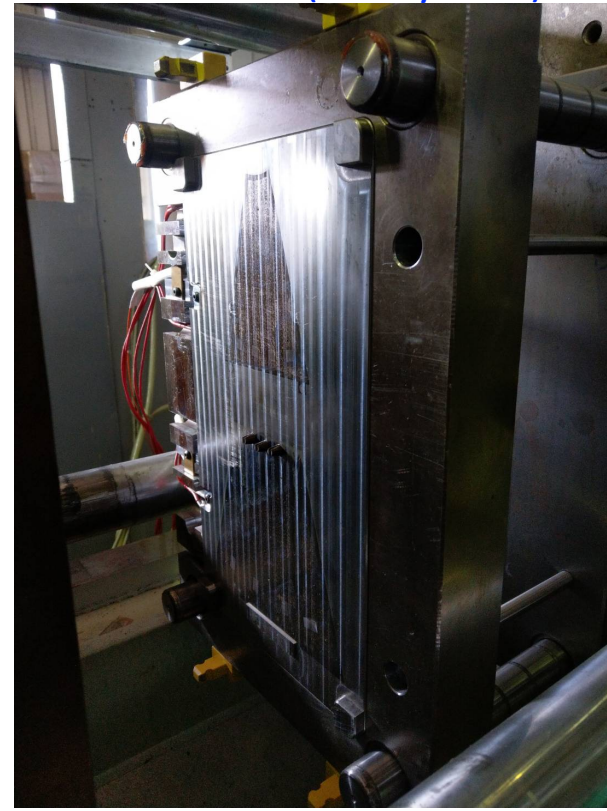

Assembly Procedure: Facilities

- ❑ Use the robotic machine at **Taiwan instrumentation Detector Consortium (TiDC)**, <https://www.taiwan-tidc.org> to assemble
 - 1) Hybrid PCBs to inner and outer structures
 - 2) Inner wedge and outer wedge
- ➔ Moving smoothly at TiDC

Optical Gauging Products (OGP)

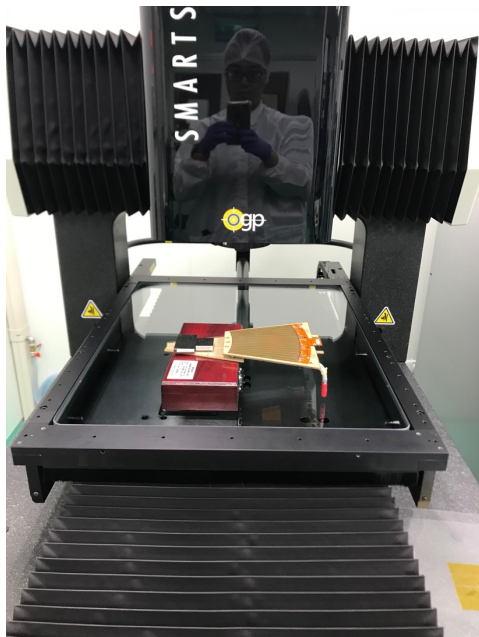

Assembly table and gantry

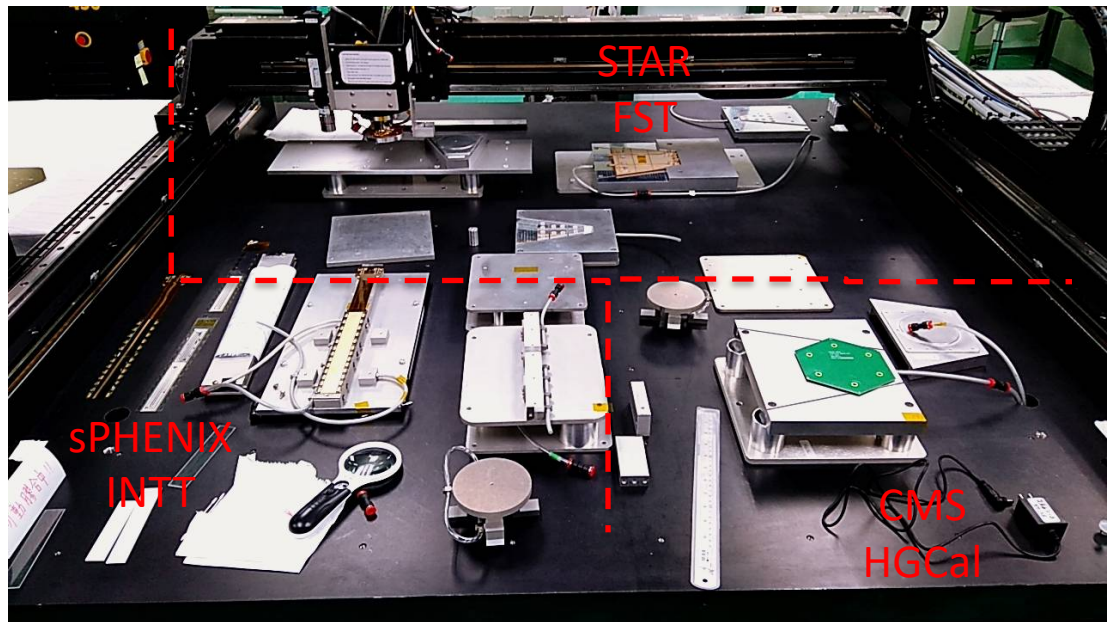

Quality Control

- ❑ Use OGP to measure the **flatness** (maximum difference between measured points)
- ❑ 5 points at chip areas and 13 (9) points at sensor area
- ❑ Acceptance: $< 500 \mu\text{m}$

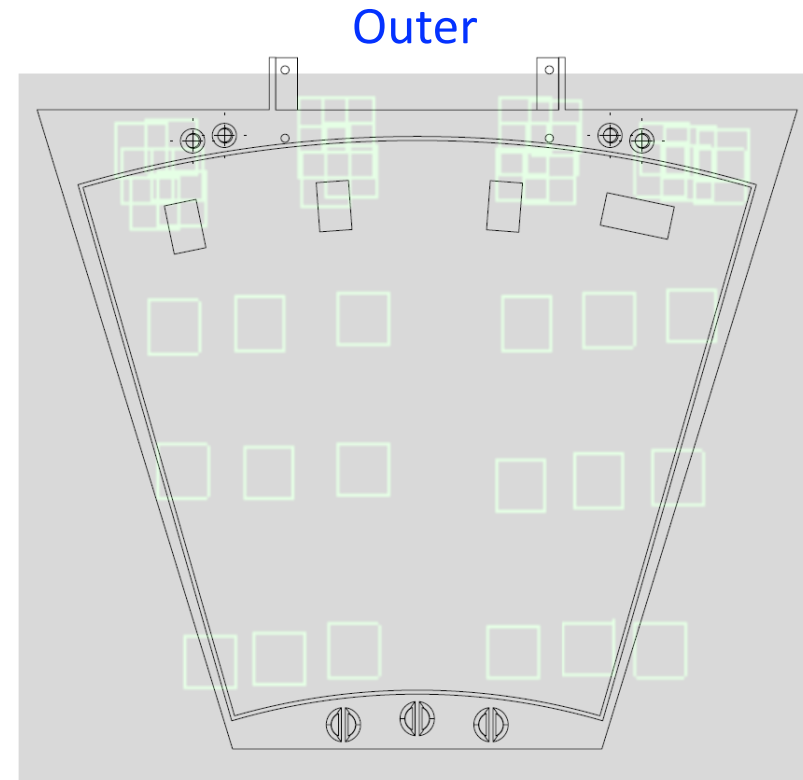
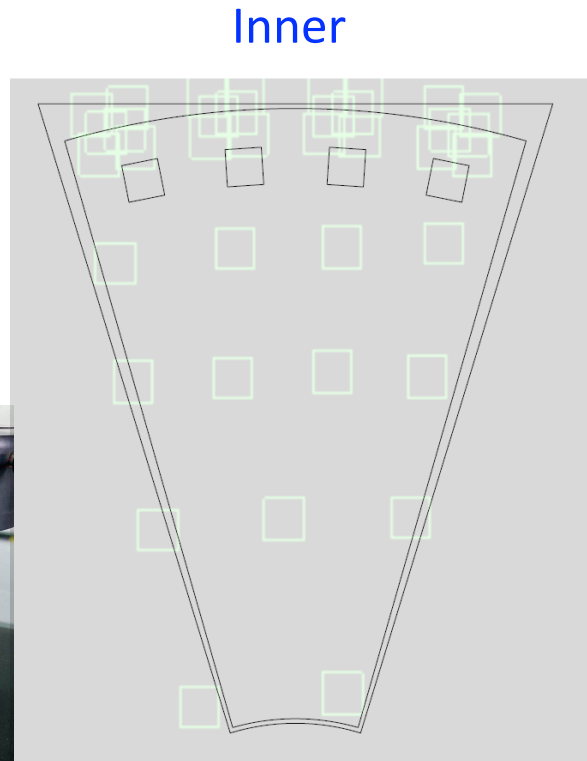
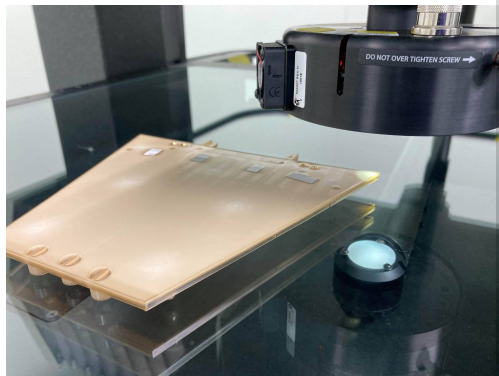
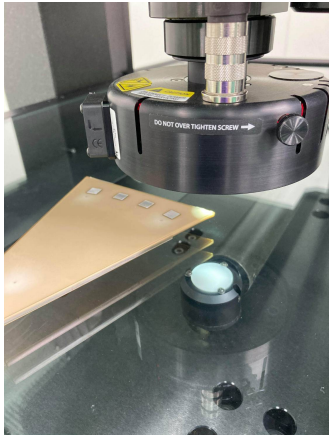

Assembly Procedure: Outer MS

- 1) Place the pickup tool, outer MS + tray, outer Hybrid + tray on table

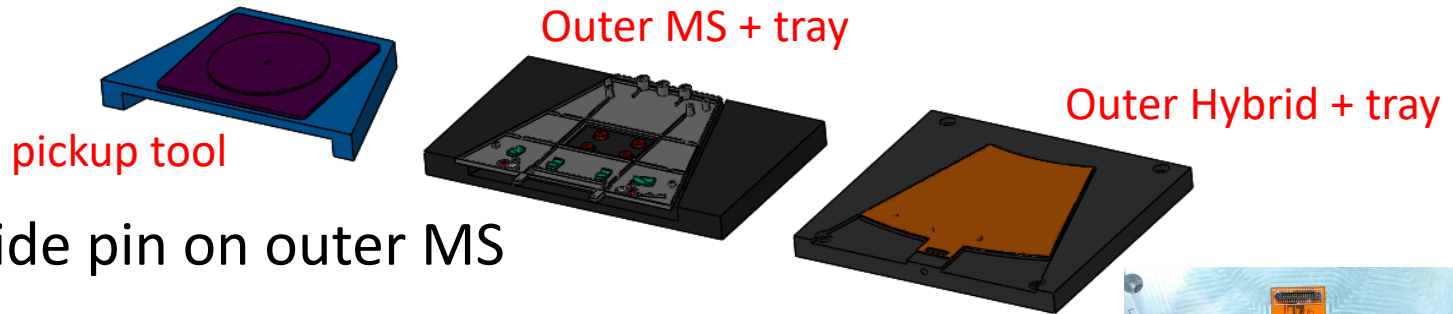

- 2) Place guide pin on outer MS
- 3) Apply glue on outer Hybrid
- 4) Use camera to locate the reference points
- 5) Glue

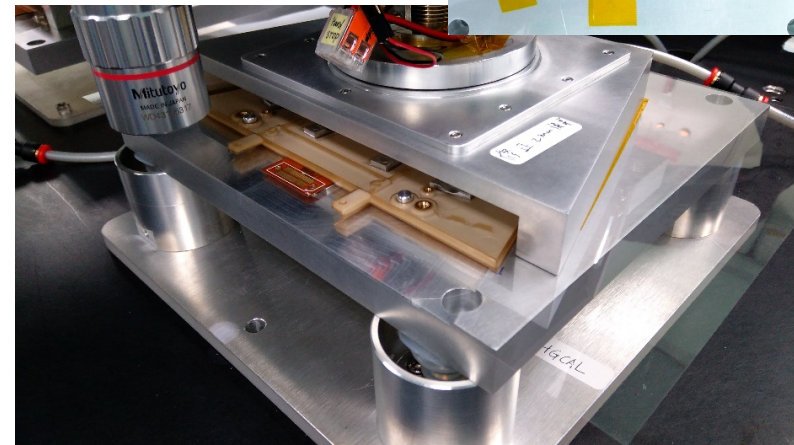
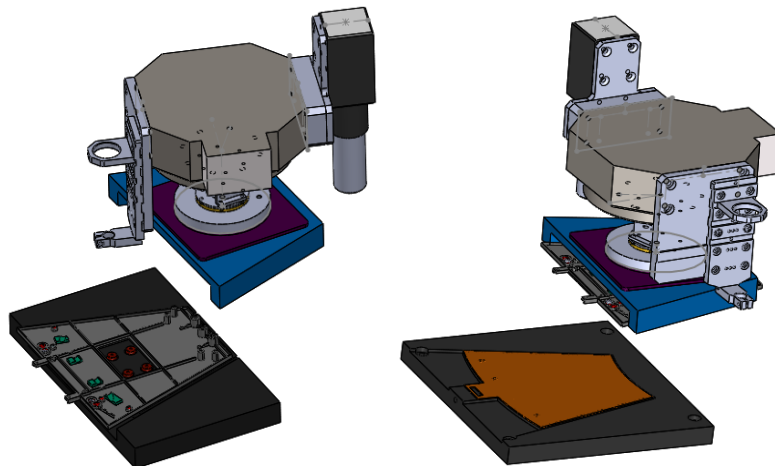



Modified Gluing Procedure for Inner Hybrid

❑ Glue the inner MS first

* Manufacturing new fixtures now

- 1) Place pickup tool, inner MS + tray, outer wedge + tray on table

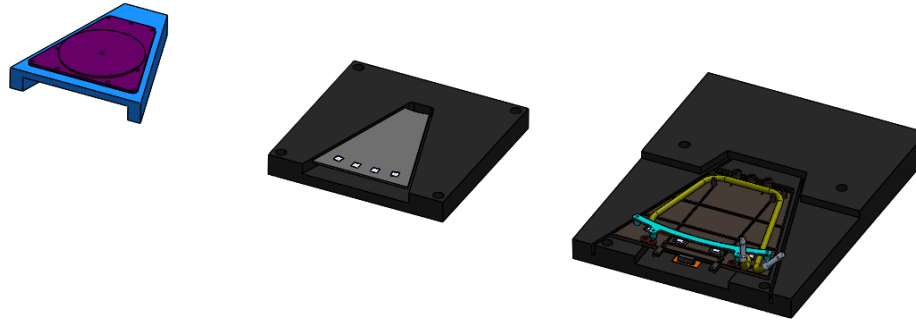

- 2) Use camera to locate reference points

- 3) Pick up inner MS and glue it on the outer wedge

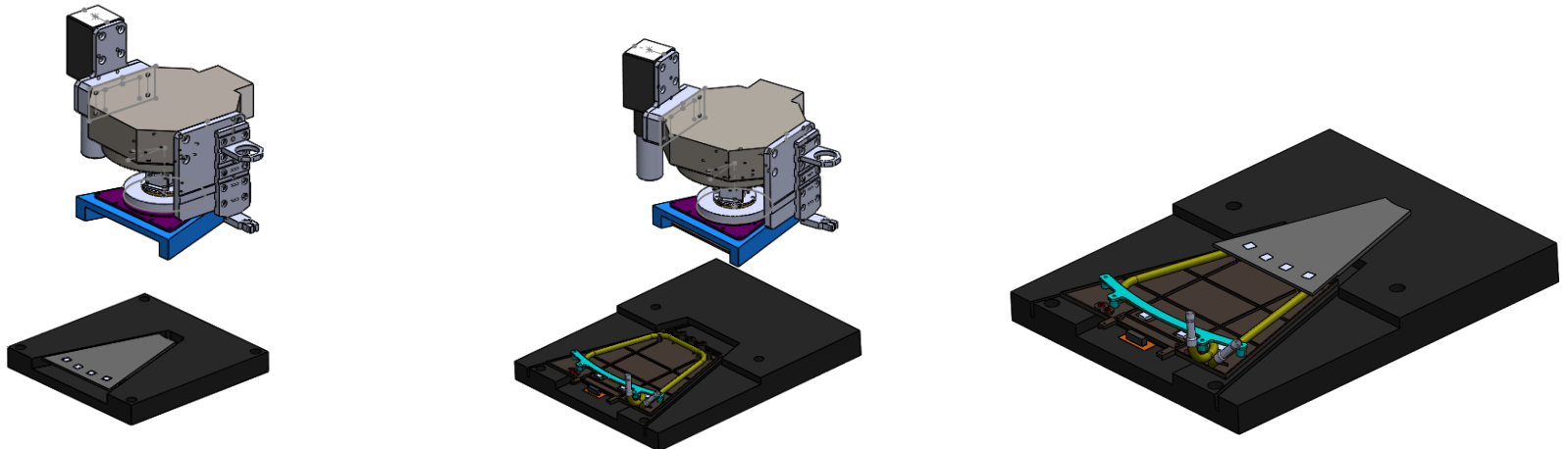



Modified Gluing Procedure for Inner Hybrid



- ❑ Follow the “same” procedure as the outer Hybrid
- 1) Place pickup tool, inner Hybrid + tray, outer wedge + inner MS + tray on table
- 2) Use camera to locate the reference points
- 3) Pick up inner Hybrid and glue it on the inner MS

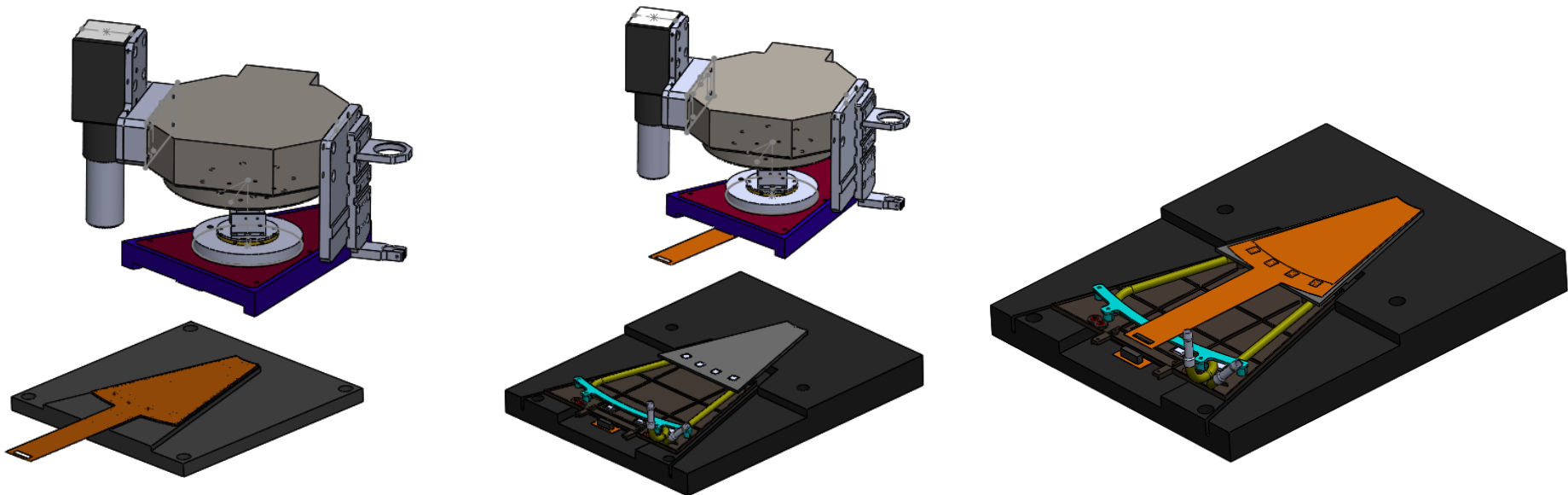

- 1) Solder components manually
- 2) Electrical open connection test

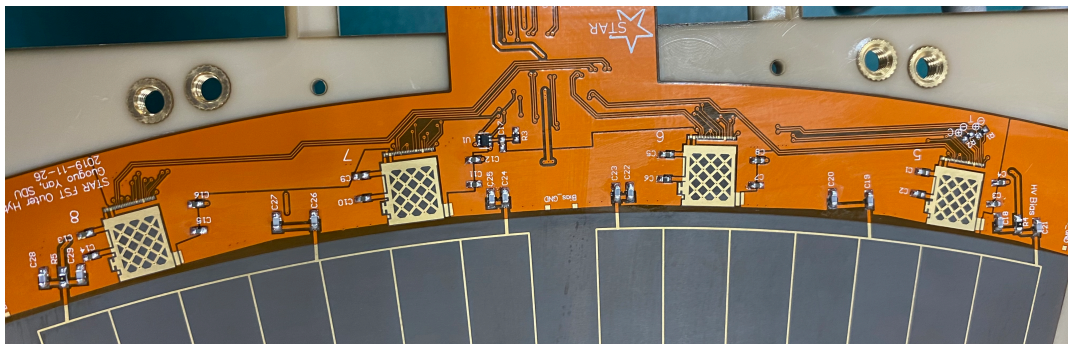
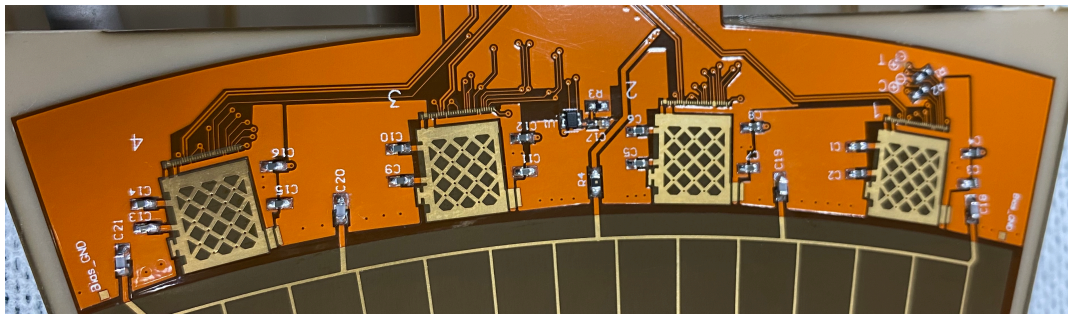



Prototypes: FST-003, FST-004, FST-005



FST-003



FST-004



Not used

FST-005





QC: FST-003, FST-004, FST-005



[μm]	FST-003		FST-004		Not used FST-005 (No components soldered)	
	Inner	Outer	Inner	Outer	Inner	Outer
Flatness sensor 1	155	233	196	130	237	145
Flatness Sensor 2		221		158		
Flatness Chip 1	62	34	31	38	31	38
Flatness Chip 2	25	43	76	41	17	34
Flatness Chip 3	32	31	121	63	43	29
Flatness Chip 4	3	30	52	39	38	54
δD1	98	61	98	83	105	1
δD2	86	174	86	58	151	67

*Flatness measurements are on Hybrids

Modified Mechanical Structure

- ❑ Implemented the suggestions from Rahul's team
 - Precision bushings and pins (inner holes), larger through holes (outer holes)
 - Add inner supporting part (screw hole)

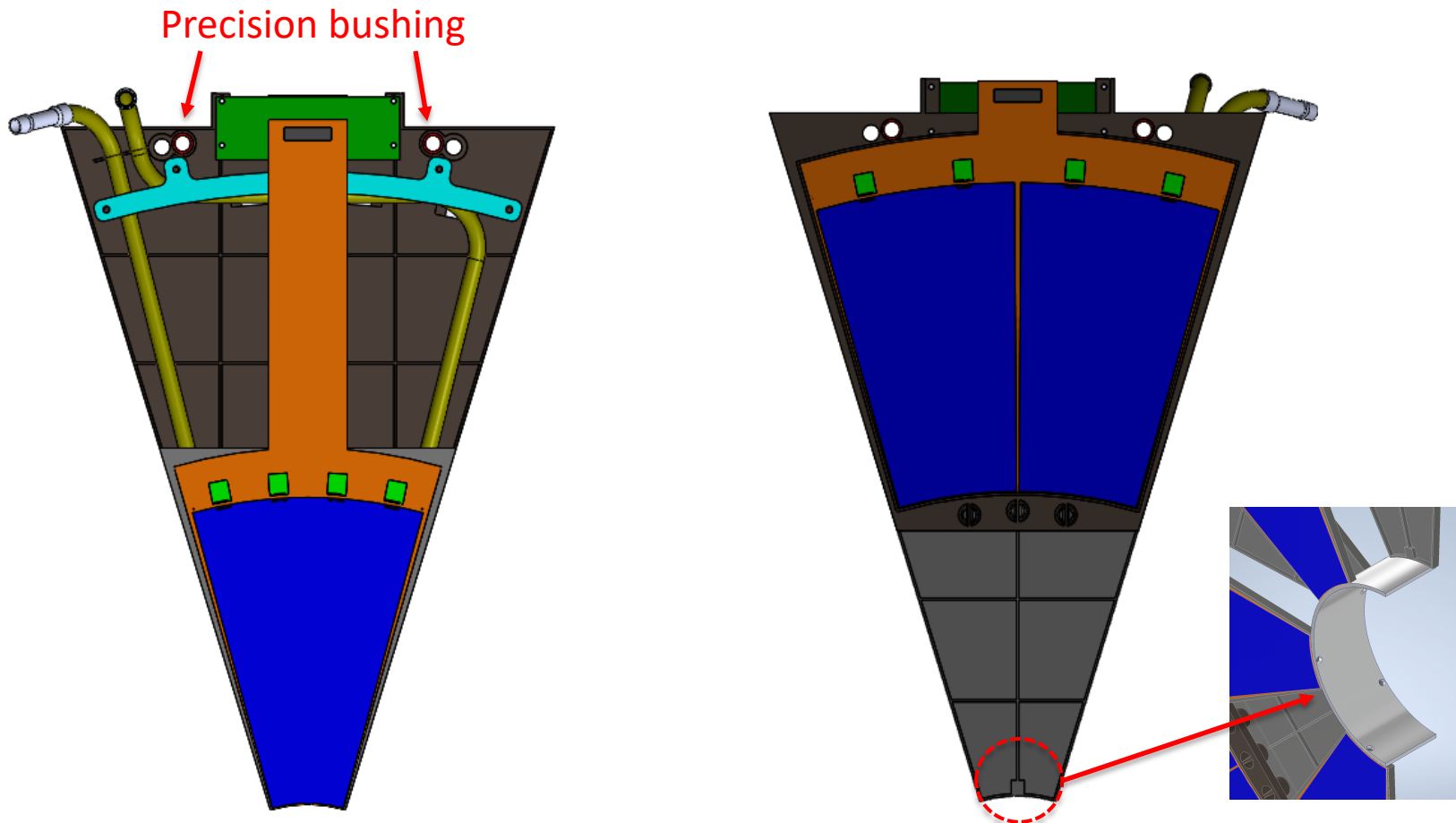

Production Phase

- ❑ The production started at the beginning of October (**FST-06 -**)
- ❑ Production is moving smoothly: 5 modules/week

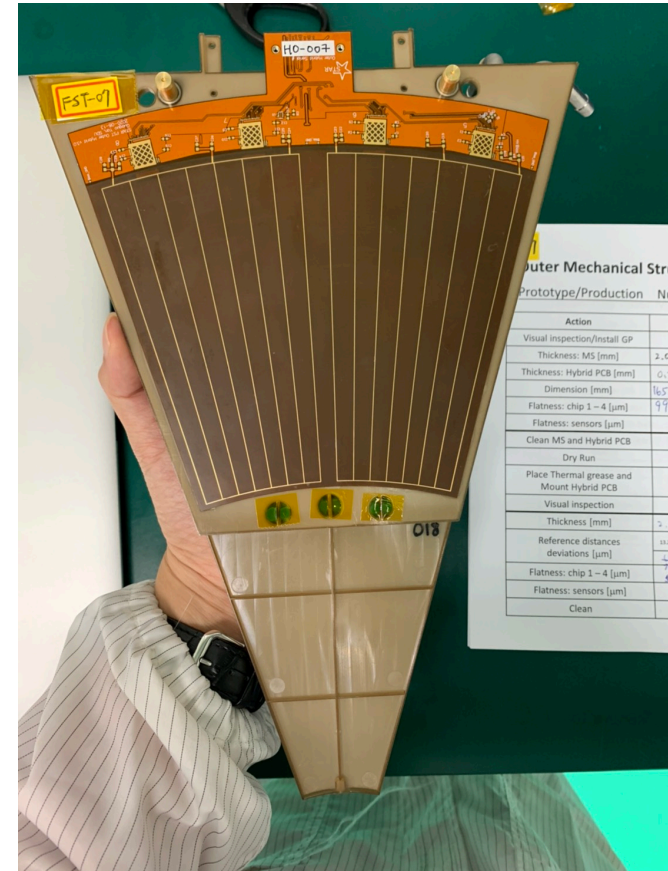

QA for Production

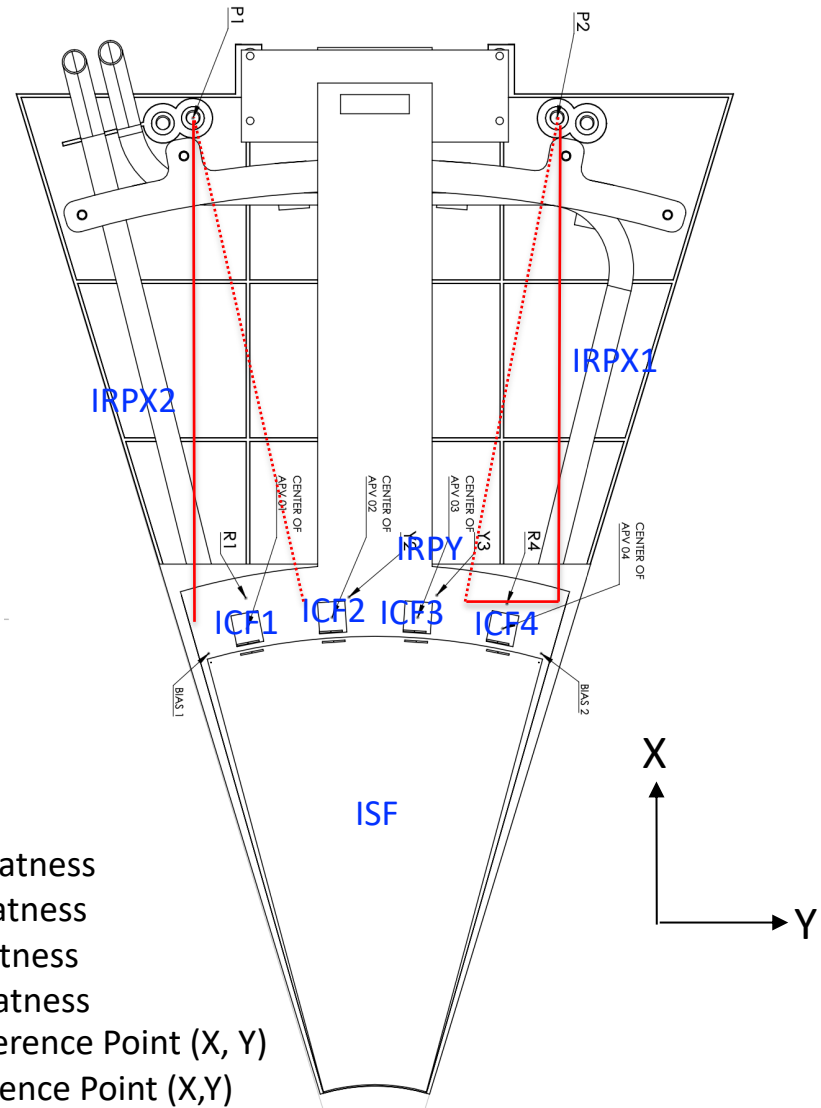
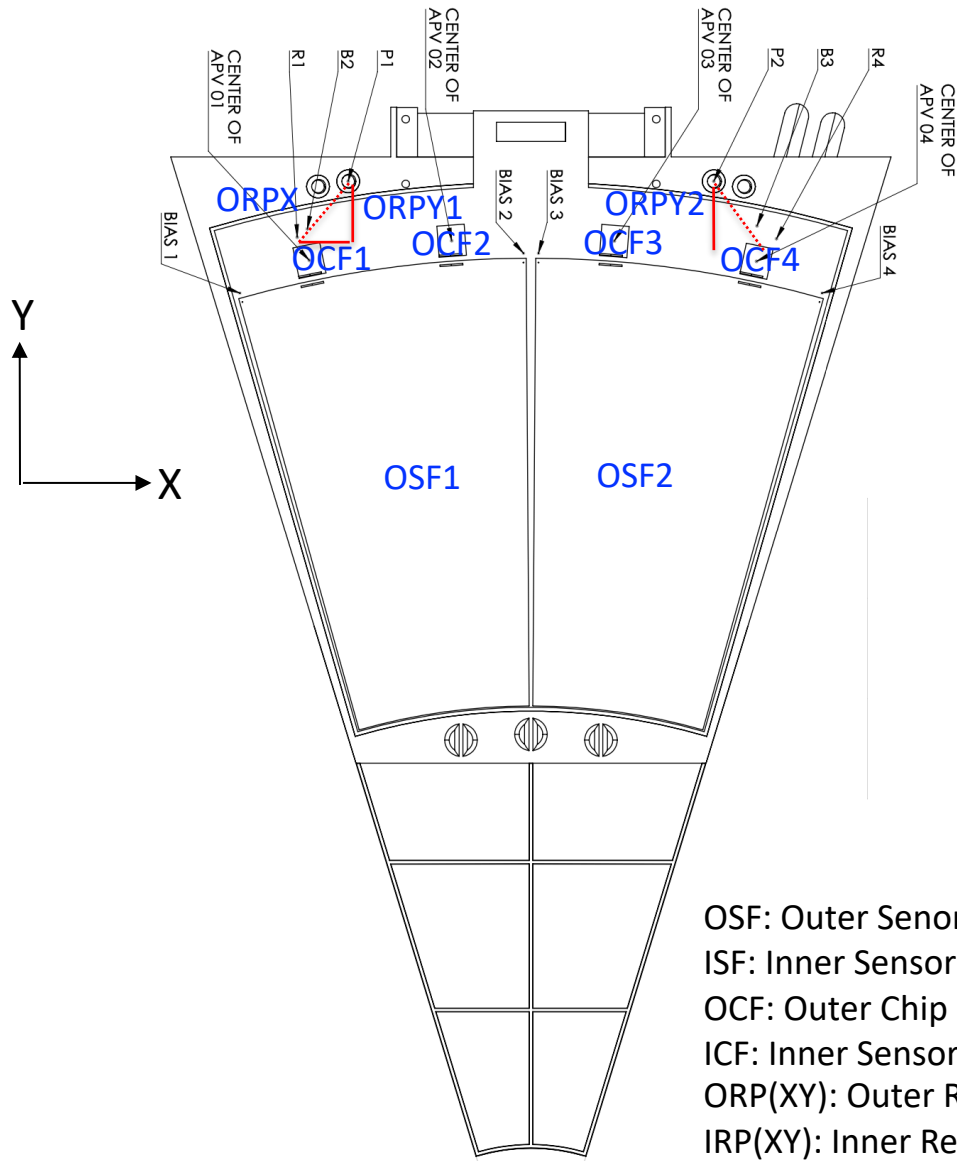

OSF: Outer Sensor Flatness
 ISF: Inner Sensor Flatness
 OCF: Outer Chip Flatness
 ICF: Inner Sensor Flatness
 ORP(XY): Outer Reference Point (X, Y)
 IRP(XY): Inner Reference Point (X,Y)



Production Statistics

□ All the measurements are recorded on Google Sheet:

<https://docs.google.com/spreadsheets/d/1YLm95aj0zIxxCnsfy0XVoxel9FWD4RHUv-Pe4qCOfSc/edit?usp=sharing>

Module ID	OSF1	OSF2	ISF	OCF1	OCF2	OCF3	OCF4	ICF1	ICF2	ICF3	ICF4	ORPX1	ORPY	ORPY2
FST-11	207.36	194.35	286.39	97.19	59.43	31.42	73.15	60.58	98.73	133.33	89.85	41.12	6.08	6.75
FST-12	285.54	230.17	329.6	110.12	56.26	131.73	55.3	17.22	85.92	83.71	32.61	59.59	29.96	30.56
FST-13	246.73	165.61	387.82	58.05	113.73	57.96	25.07	188.06	173.58	197.44	124.9	47.81	9.13	40.68
FST-14	350.48	191.1	207.8	91.41	120.57	183.44	18.95	10.41	12.99	53.68	18.26	20.67	26	17.49
FST-15	299.74	231.05	247.37	26.59	66.23	60.56	60.68	87.93	96.57	112.93	93.02	7.39	17.95	1.62
FST-16	223.66	208.09	347.64	41.48	122.14	24.98	65.22	45.09	99.86	111.18	69.67	52.96	71.88	40.93
FST-17	193.94	177.52	148.62	83.07	48.64	62.03	69.88	106.19	109.41	121	76.97	99.08	45.04	26.45
FST-18	194.51	186.23	217.09	45.59	24.77	73.35	55.62	48.08	52.21	95.42	53.15	50.77	6.57	17.26
FST-19	194.63	222.71	308.47	58.62	49.05	34.73	54.15	28.03	99.43	103.29	66.71	98.54	6.99	92.65
FST-20	290.91	199.34	40.22	59.38	55.12	76.72	57.72	56.33	113.15	135.63	98.1	6.96	47.86	14.4
FST-21	131.72	94.04	100.09	65.97	110.06	33.42	72.89	69.01	132.39	162.31	87.64	108.11	14.89	20.75
FST-22	136.28	128.44	152.55	92.76	135.82	68.95	54.76	116.37	164.88	205.1	146.78	35.08	20.65	16.85
FST-23	85.3	159.93	37.5	107.18	120.74	92.29	110.59	12.1	46.48	40.75	36.32	84.1	6.51	18.17
FST-24	204.53	200.03	88.62	45.62	92.2	116.51	94.46	24.68	70.43	96.06	65.1	53.19	18.53	30.46
FST-25	251.82	135.2	96.23	44.96	123.47	61.34	78.09	56.97	107.33	106.81	64.3	36.01	0.44	57.84
FST-26	208.01	138.57	375.38	49.37	83.94	19.86	46.75	27.04	35.2	51.12	30.02	51.12	21.89	8.24
FST-27	170.18	206.67	145.83	63.82	82.6	94.26	107.16	68.93	140.57	145.54	109.35	66.91	82.6	18.16
FST-28	146.378	153.47	91.27	63.71	87.16	57.88	46.47	38.71	69.65	92.77	61.35	15.53	9.79	40.45



Production Statistics

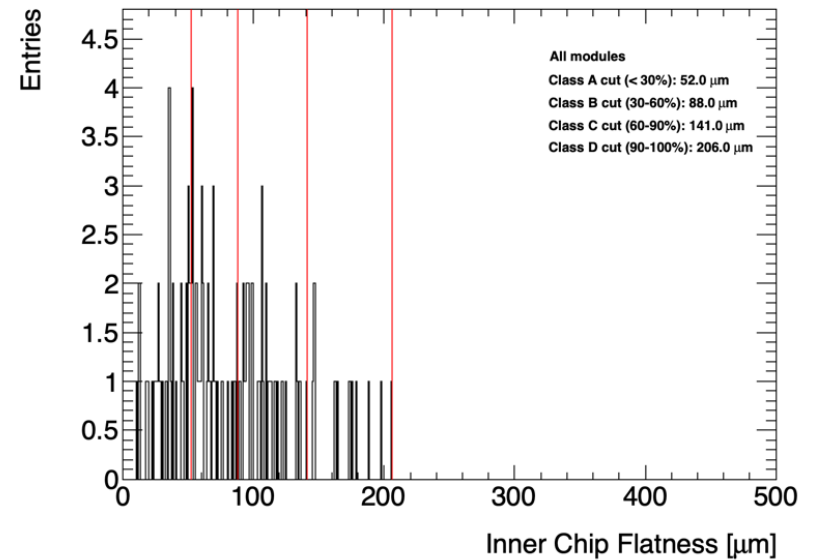
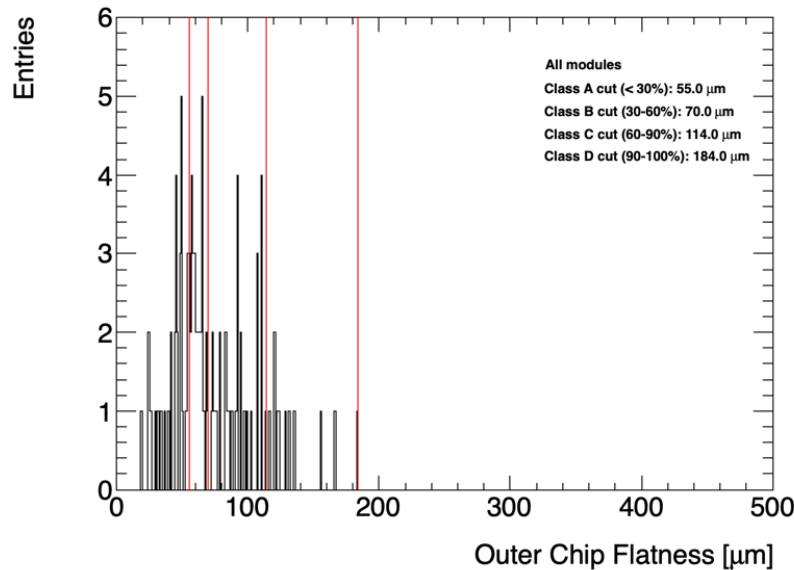
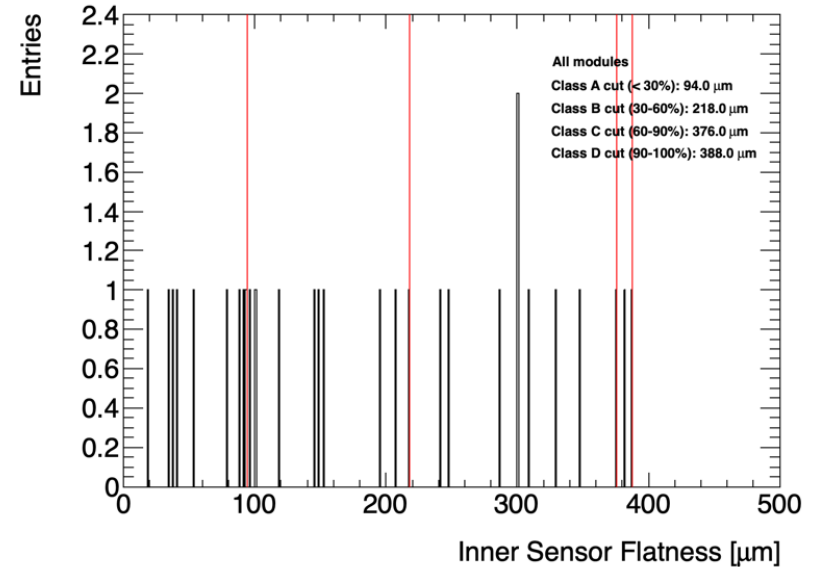
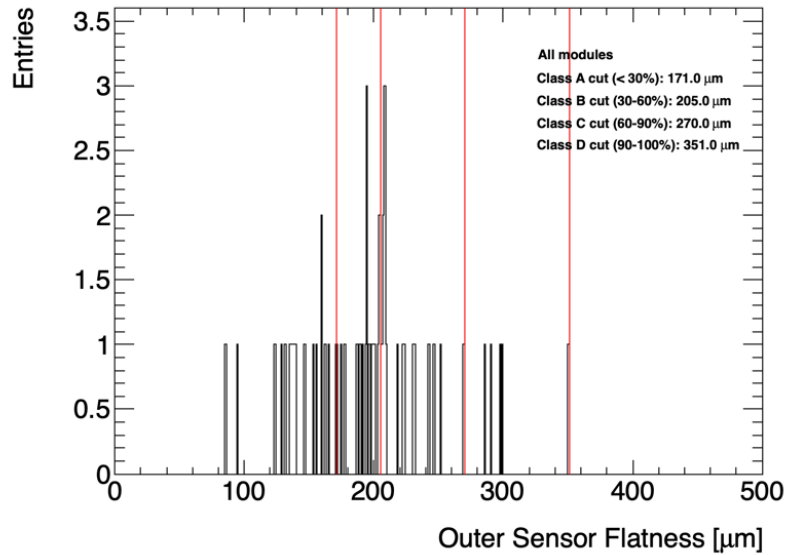



Production Statistics

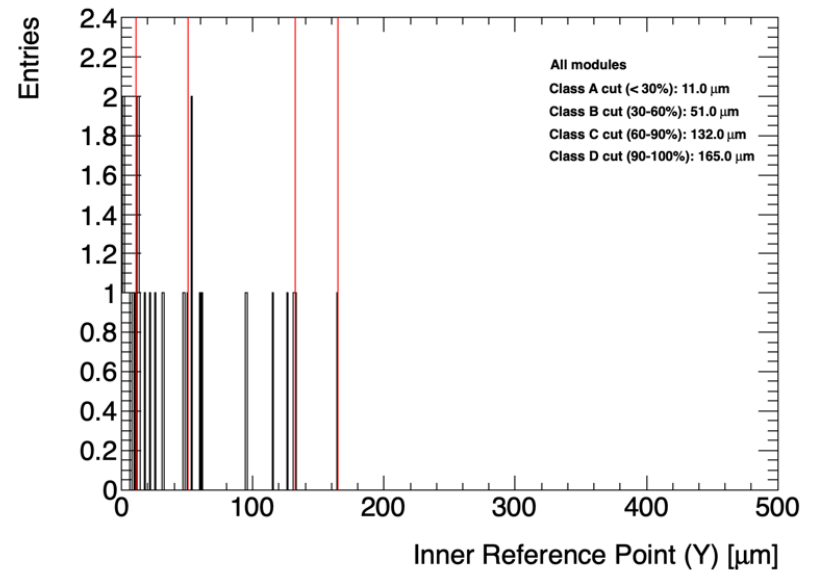
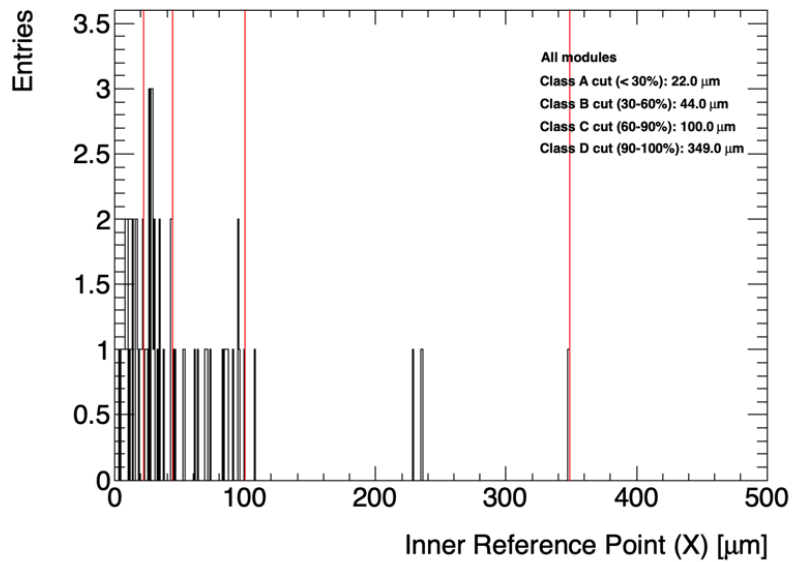
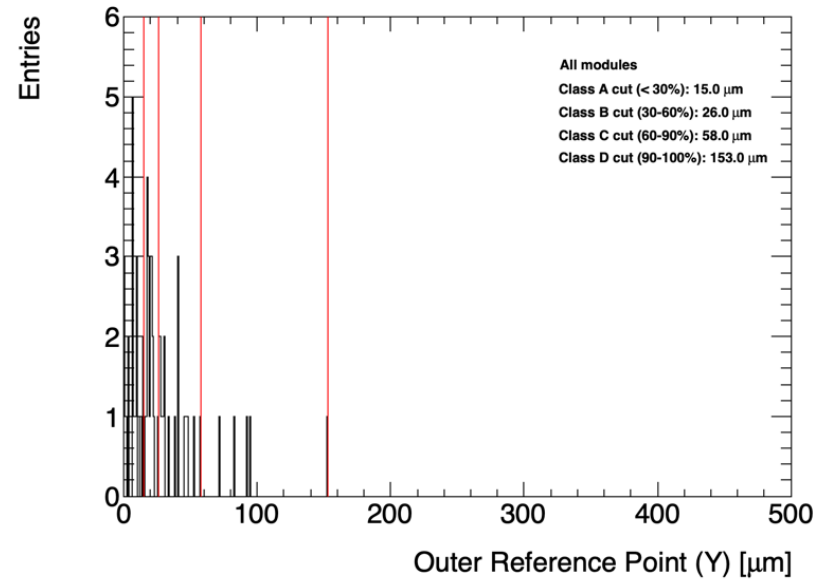
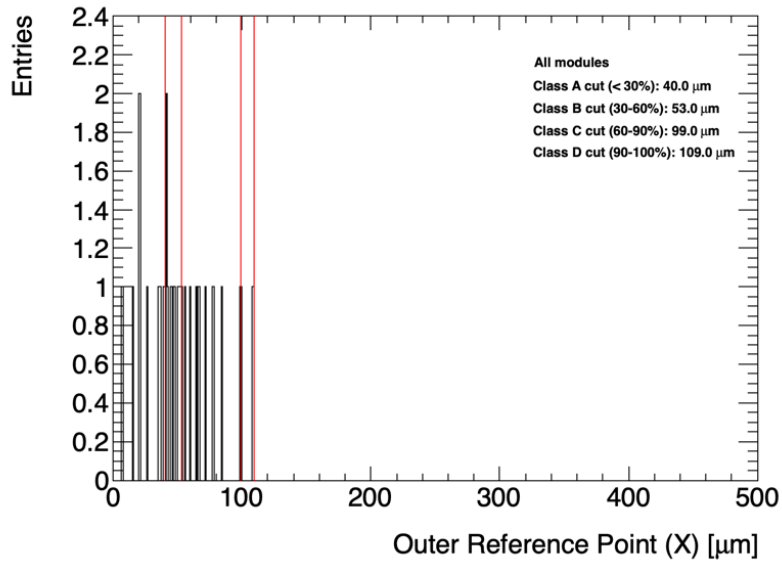



Grading Matrix

- Assumption: all modules are good unless it encounters some technical issue, e.g. overflow glue...

		A: < 30 % (100 pts)	B: 30 – 60% (90 pts)	C: 60 – 90% (80 pts)	D: > 90 % (60 pts)
OSF x 2 (25%)		< 171 μm	171 – 205 μm	205 – 270 μm	270 – 351 μm
ISF (25%)		< 94 μm	94 – 218 μm	218 – 276 μm	376 – 388 μm
OCF x 4 (10%)		< 55 μm	55 – 70 μm	70 – 114 μm	114 – 184 μm
ICF x 4(10%)		< 52 μm	52 – 88 μm	88 – 141 μm	141 – 206 μm
ORP (15%)	X	< 40 μm	40 – 53 μm	53 – 99 μm	99 – 109 μm
	Y x 2	< 15 μm	15 – 26 μm	26 – 58 μm	58 – 153 μm
IRP (15%)	Y	< 11 μm	11 – 51 μm	51 – 132 μm	132 – 165 μm
	X x 2	< 22 μm	22 – 44 μm	44 – 100 μm	100 – 349 μm



Final Class

Based on FST-07 to FST-35

Class C
< 84

Class B
84 - 92

Class A
> 92

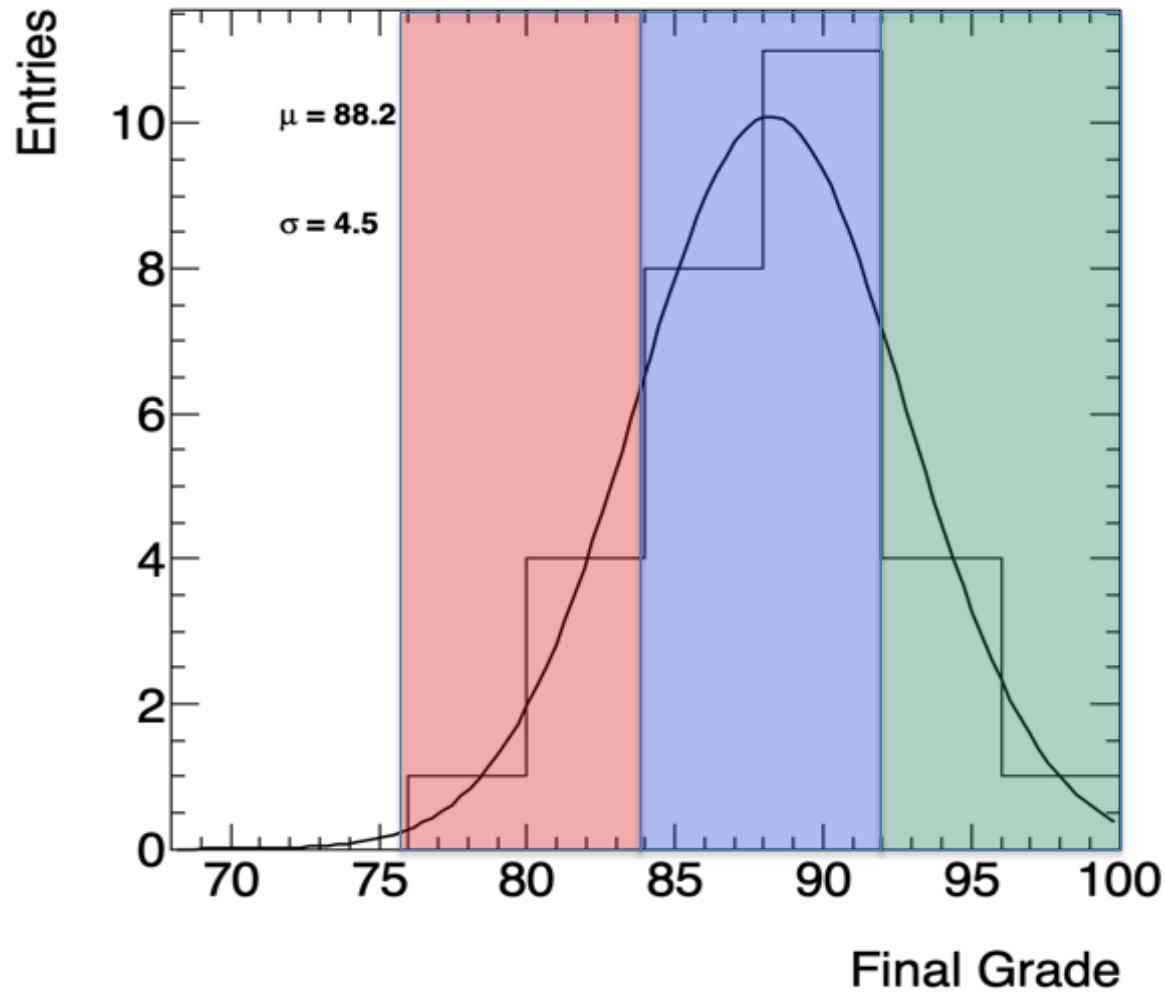



Final Grades



<https://docs.google.com/spreadsheets/d/1YLm95aj0zIxxCnsfy0XVoxel9FWD4RHUv-Pe4qCOfSc/edit?usp=sharing>

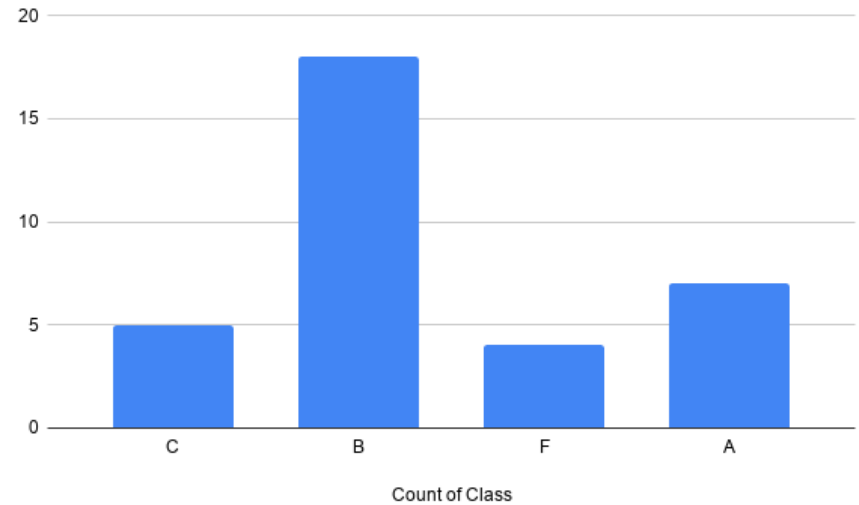
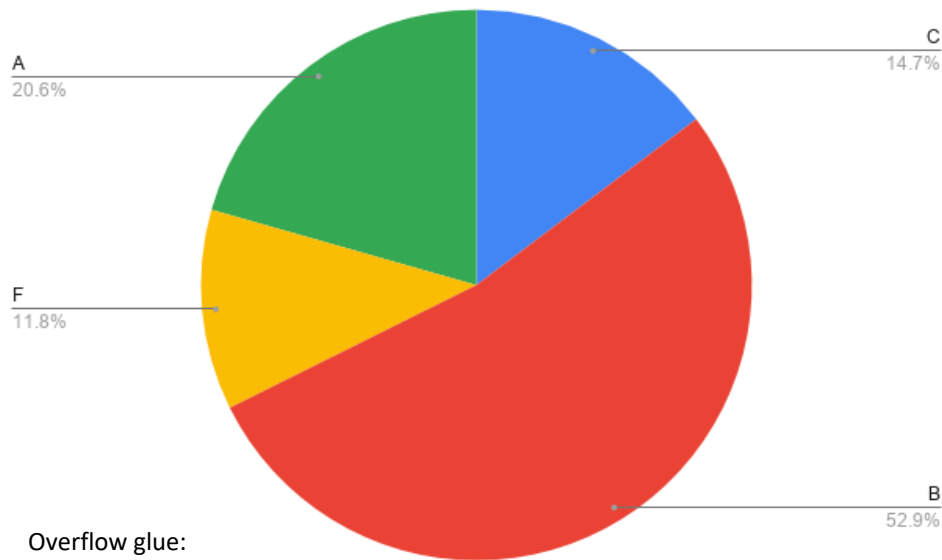

Overflow glue:

- FST-19
- FST-23
- FST-32

Inner hybrid shifted:

- FST-40



Production Qualities: Class A

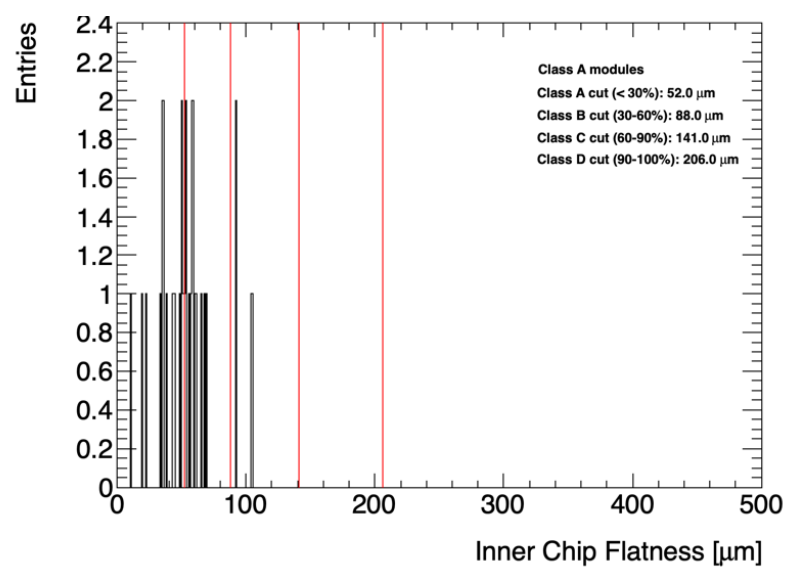
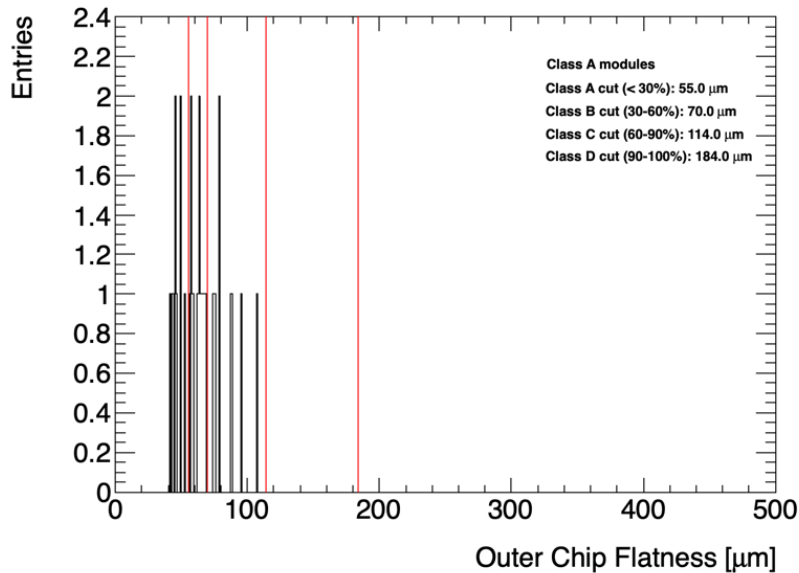
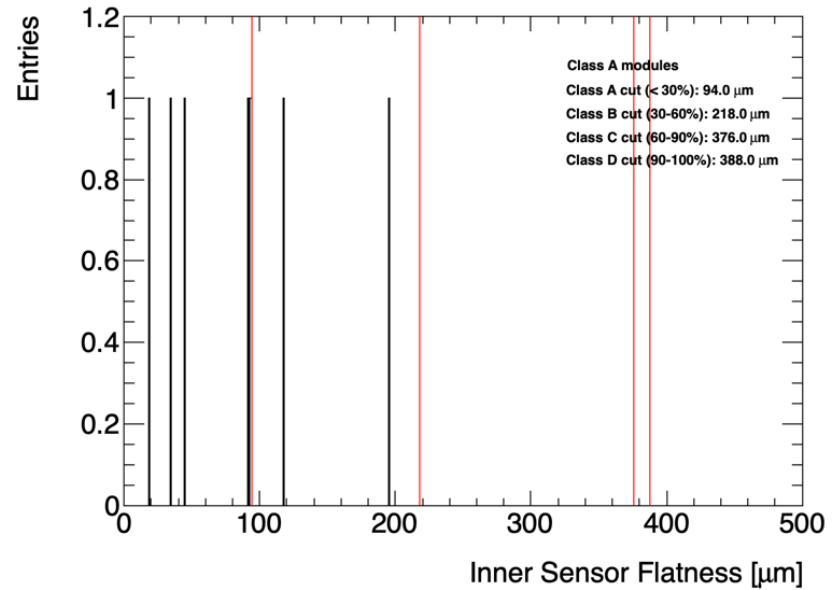
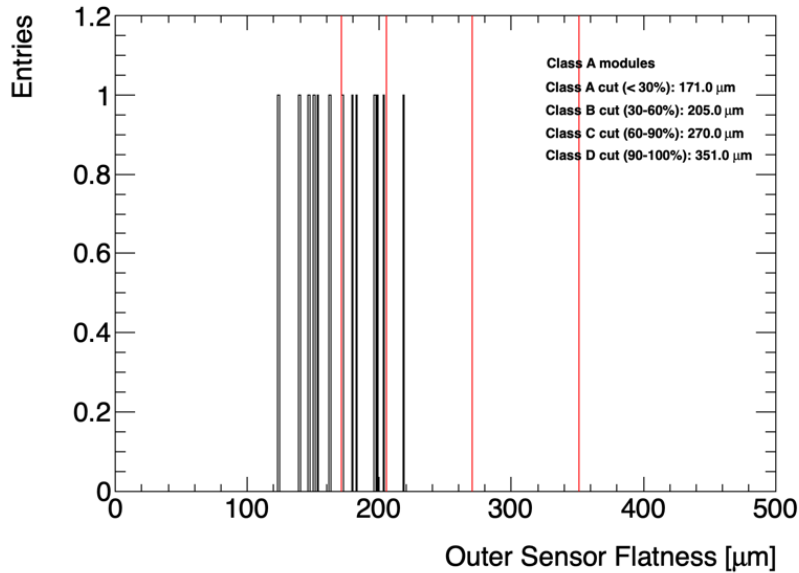



Production Qualities: Class A

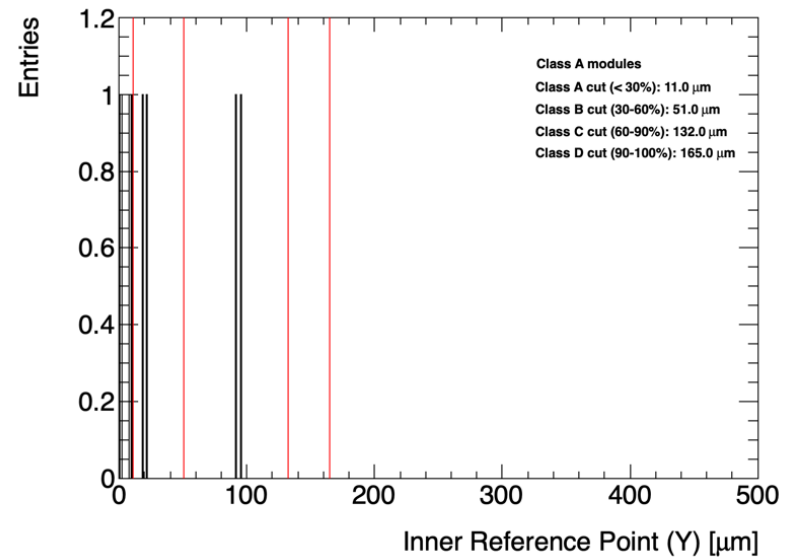
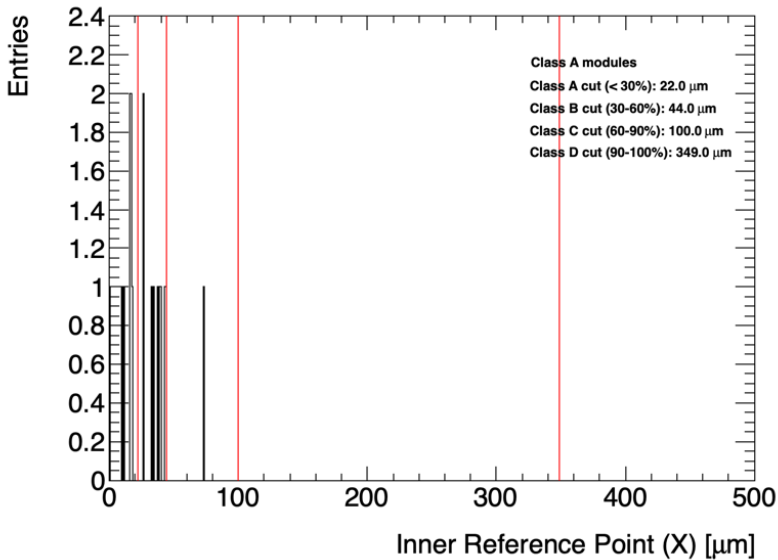
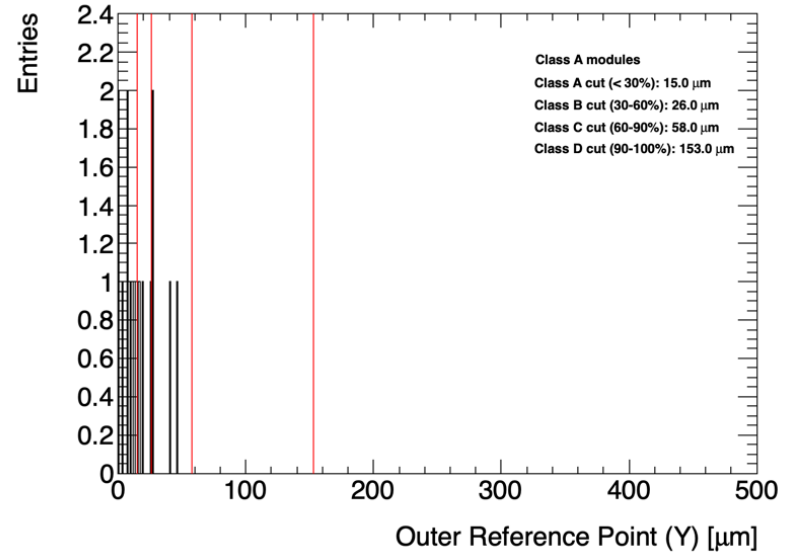
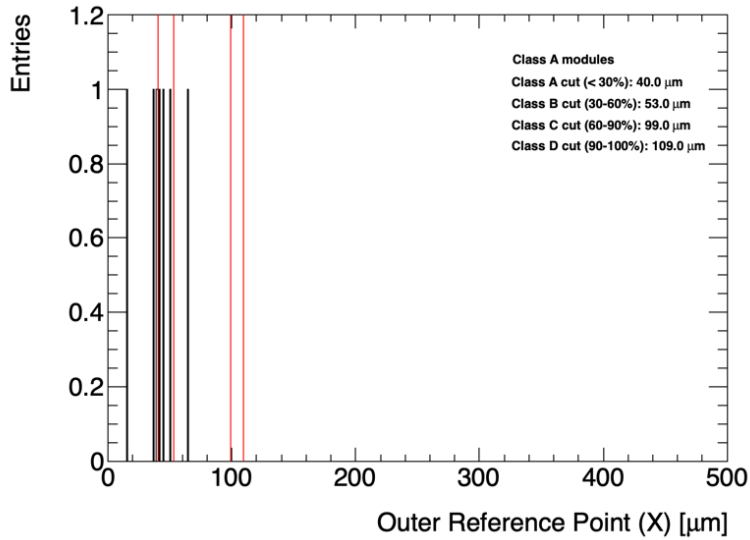



E-Log



E-log: <http://leto.phy.uic.edu:8080/FST/>

Several logbooks are defined on this host.
Please select the one to connect to:

Logbook	Entries	Last submission
General FST STAR FST Module Assembly Database	0	-
FST01 STAR FST Module Assembly Database	0	-
FST02 STAR FST Module Assembly Database	1	Tue Dec 1 21:34:23 2020 by Yi Yang
FST03 STAR FST Module Assembly Database	4	
FST04 STAR FST Module Assembly Database	5	
FST05 STAR FST Module Assembly Database	3	
FST06 STAR FST Module Assembly Database	1	
FST07 STAR FST Module Assembly Database	1	
FST08 STAR FST Module Assembly Database	1	
FST09 STAR FST Module Assembly Database	4	
FST10 STAR FST Module Assembly Database	4	
FST11 STAR FST Module Assembly Database	4	
FST12 STAR FST Module Assembly Database	4	
FST13 STAR FST Module Assembly Database	4	
FST14 STAR FST Module Assembly Database	3	
FST15 STAR FST Module Assembly Database	3	
FST16 STAR FST Module Assembly Database	3	
FST17 STAR FST Module Assembly Database	3	
FST18 STAR FST Module Assembly Database	3	

General FST | FST01 | FST02 | FST03 | FST04 | FST05 | FST06 | FST07 | FST08 | FST09 | FST10 | **FST11** | FST12 | FST13 | FST14 | FST15 | FST16 | FST17 | FST18 | FST19 | FST20 | FST21 | FST22 | FST23 | FST24 | FST25 | FST26 | FST27 | FST28 | FST29 | FST30 | FST31 | FST32 | FST33 | FST34 | FST35 | FST36 | FST37 | FST38 | FST39 | FST40 | FST41 | FST42 | FST43 | FST44 | FST45 | FST46 | FST47 | FST48 | FST49 | FST50 | FST51 | FST52 | FST53 | FST54 | FST55 | FST56 | FST57 | FST58 | FST59 | FST60 | Overview FST

STAR FST Module Assembly Database, Page 1 of 1

New | Find | Select | Import | Config | Last day | Help

Full | Summary | Threaded

-- Author -- -- Location -- -- Operator -- 4 Entries

ID	Date	Author	Location	Operation	Operator	Start Time	End Time	Weight Before Operation	Weight After Operation	Visual Inspection Before Operation	Additional Comment	Text
4	Fri Dec 4 10:01:42 2020	Yi Yang	NCKU	ship to US		Dec. 04, 2020	Dec. 04, 2020					
3	Mon Nov 30 21:57:40 2020	Yi Yang	NCKU	inspection		Nov. 30, 2020	Nov. 30, 2020				Class B	
2	Mon Nov 30 21:57:18 2020	Yi Yang	NCKU	mount electronic components		Nov. 28, 2020	Nov. 28, 2020					
1	Mon Nov 30 21:56:57 2020	Yi Yang	NCKU	assemble the hybrids on MS		Nov. 17, 2020	Nov. 17, 2020					



Production Schedule

DECEMBER 2020						
Sunday	Monday	Tuesday	Wednesday	Thursday	Friday	Saturday
29	30	1	2	3	4	5
6	7 Clean room maintenance	8	9 FST-18 (4) FST-19 (3) FST-20 (1)	10 FST-19 (4) FST-20 (2) FST-21 (1)	11 FST-20 (3) FST-21 (2) FST-22 (1)	12
13 FST-14 (5) FST-15 (5) FST-16 (5) FST-17 (5)	14 FST-20 (4) FST-21 (3) FST-22 (2) FST-23 (1)	15 FST-21 (4) FST-22 (3) FST-23 (2) FST-24 (1)	16 FST-22 (4) FST-23 (3) FST-24 (2) FST-25 (1)	17 FST-23 (4) FST-24 (3) FST-25 (2) FST-26 (1)	18 FST-24 (4) FST-25 (3) FST-26 (2) FST-27 (1)	19
20 FST-18 (5) FST-19 (5) FST-20 (5) FST-21 (5) FST-22 (5)	21 FST-25 (4) FST-26 (3) FST-26 (2) FST-27 (1)	22 FST-26 (4) FST-27 (3) FST-28 (2) FST-29 (1)	23 FST-27 (4) FST-28 (3) FST-29 (2) FST-30 (1)	24 FST-28 (4) FST-29 (3) FST-30 (2) FST-31 (1)	25 FST-29 (4) FST-30 (3) FST-31 (2) FST-32 (1)	26
27 FST-23 (5) FST-24 (5) FST-25 (5) FST-26 (5) FST-27 (5)	28 FST-30 (4) FST-31 (3) FST-32 (2) FST-33 (1)	29 FST-31 (4) FST-32 (3) FST-33 (2) FST-34 (1)	30 FST-32 (4) FST-33 (3) FST-34 (2) FST-35 (1)	31 FST-33 (4) FST-34 (3) FST-35 (2) FST-36 (1)	1	2

Printable Calendars by Betacalendars.com



Production Schedule

JANUARY 2021						
Sunday	Monday	Tuesday	Wednesday	Thursday	Friday	Saturday
27	28	29	30	31	1 Holiday	2
3 FST-28 (5) FST-29 (5)	4 FST-34 (4) FST-35 (3) FST-36 (2) FST-37 (1)	5 FST-35 (4) FST-36 (3) FST-37 (2) FST-38 (1)	6 FST-36 (4) FST-37 (3) FST-38 (2) FST-39 (1)	7 FST-37 (4) FST-38 (3) FST-39 (2) FST-40 (1)	8 FST-38 (4) FST-39 (3) FST-40 (2) FST-41 (1)	9
10 FST-30 (5) FST-31 (5) FST-32 (5) FST-33 (5) FST-34 (5)	11 FST-39 (4) FST-40 (3) FST-41 (2) FST-42 (1)	12 FST-40 (4) FST-41 (3) FST-42 (2) FST-43 (1)	13 FST-41 (4) FST-42 (3) FST-43 (2) FST-44 (1)	14 FST-42 (4) FST-43 (3) FST-44 (2) FST-45 (1)	15 FST-43 (4) FST-44 (3) FST-45 (2) FST-46 (1)	16
17 FST-35 (5) FST-36 (5) FST-37 (5) FST-38 (5) FST-39 (5)	18 FST-44 (4) FST-45 (3) FST-46 (2) FST-47 (1)	19 FST-45 (4) FST-46 (3) FST-47 (2) FST-48 (1)	20 FST-46 (4) FST-47 (3) FST-48 (2) FST-49 (1)	21 FST-47 (4) FST-48 (3) FST-49 (2) FST-50 (1)	22 FST-48 (4) FST-49 (3) FST-50 (2) FST-51 (1)	23
24 FST-40 (5) FST-41 (5) FST-42 (5) FST-43 (5) FST-44 (5)	25 FST-49 (4) FST-50 (3) FST-51 (2) FST-52 (1)	26 FST-50 (4) FST-51 (3) FST-52 (2) FST-53 (1)	27 FST-54 (4) FST-55 (3) FST-56 (2) FST-57 (1)	28 FST-55 (4) FST-56 (3) FST-57 (2) FST-58 (1)	29 FST-56 (4) FST-57 (3) FST-58 (2) FST-59 (1)	30
31 FST-45 (5) FST-46 (5) FST-47 (5) FST-48 (5) FST-49 (5)	1	2	3	4	5	6

Printable Calendars by Betacalendars.com



Production Schedule

FEBRUARY 2021						
Sunday	Monday	Tuesday	Wednesday	Thursday	Friday	Saturday
31 FST-50 (5) FST-51 (5) FST-52 (5) FST-53 (5) FST-54 (5)	1 FST-57 (4) FST-58 (3) FST-59 (2) FST-60 (1)	2 FST-58 (4) FST-59 (3) FST-60 (2) FST-60 (1)	3 FST-59 (4) FST-60 (3) FST-61 (2) FST-62 (1)	4 FST-60 (4) FST-61 (3) FST-62 (2) FST-63 (1)	5 FST-61 (4) FST-62 (3) FST-63 (2) FST-64 (1)	6
7 FST-55 (5) FST-56 (5) FST-57 (5) FST-58 (5) FST-59 (5) FST-60 (5)	8 FST-62 (4) FST-63 (3) FST-64 (2) FST-65 (1)	9 FST-63 (4) FST-64 (3) FST-65 (2) FST-66 (1)	10 Chinese New Year	11 Chinese New Year	12 Chinese New Year	13
14	15 Chinese New Year	16 Chinese New Year	17 FST-64 (4) FST-65 (3) FST-66 (2) FST-67 (1)	18 FST-65 (4) FST-66 (3) FST-67 (2) FST-68 (1)	19 FST-66 (4) FST-67 (3) FST-68 (2) FST-69 (1)	20
21	22 FST-67 (4) FST-68 (3) FST-69 (2) FST-70 (1)	23 FST-68 (4) FST-69 (3) FST-70 (2) FST-71 (1)	24 FST-69 (4) FST-70 (3) FST-71 (2)	25 FST-70 (4) FST-71 (3)	26 FST-71 (4)	27
28	1	2	3	4	5	6

Printable Calendars by Betacalendars.com

Thermal Analysis

- Careful thermal analysis is performed by using single module with water cooling
- Temperature at thermal equilibrium is less than 26 °C**

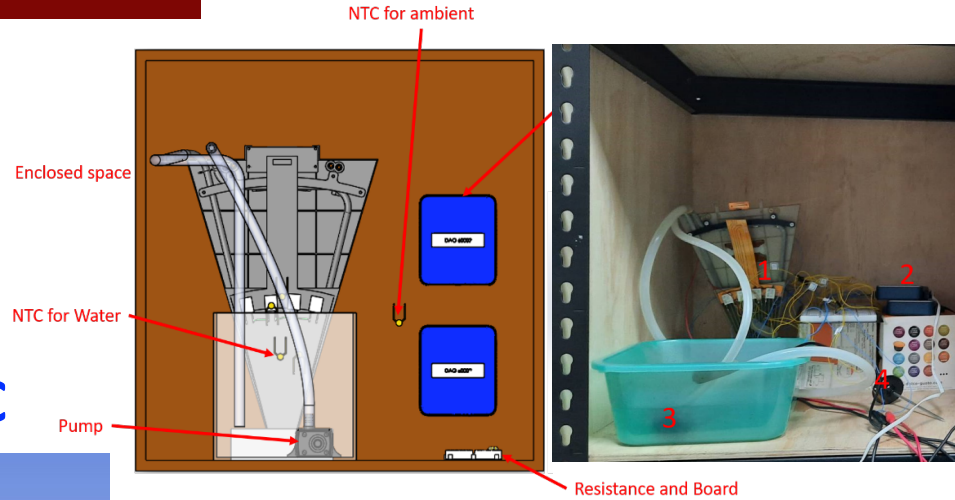

Consistent results between experiments and simulation
0.25W

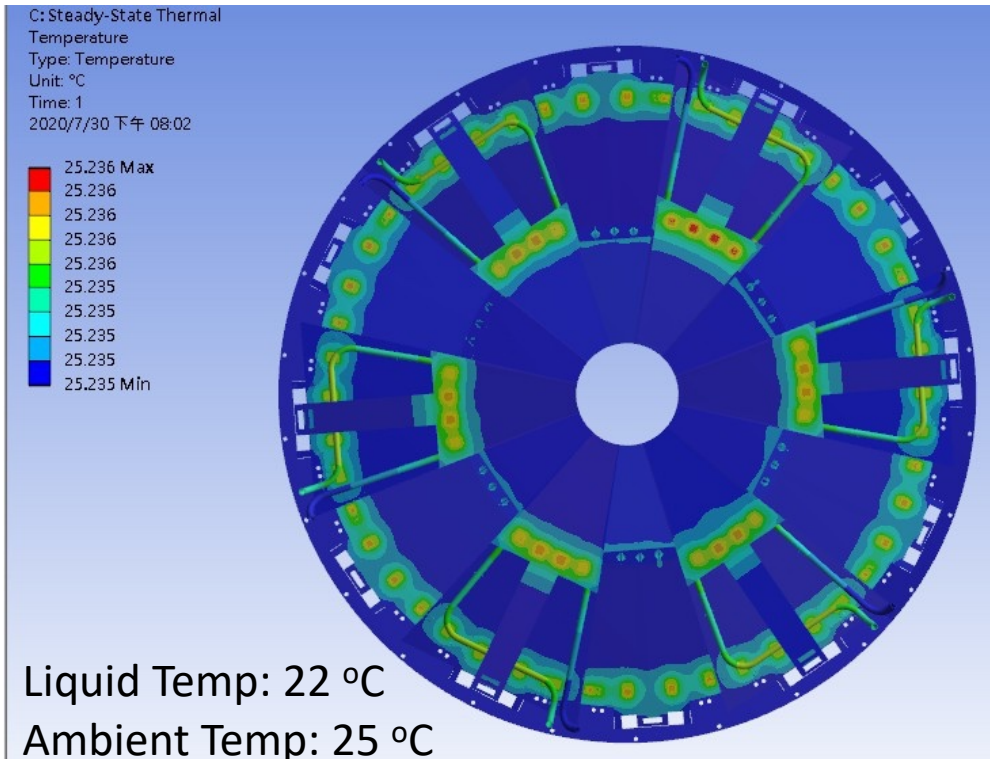
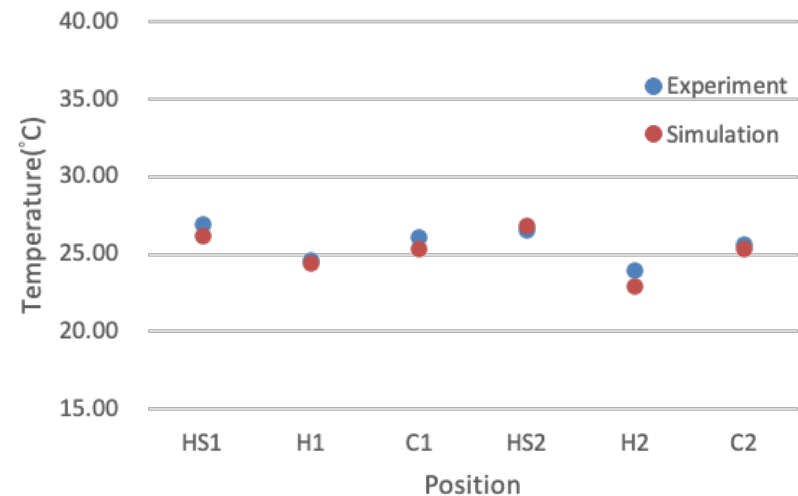

❑ Cooling test on FST-04

(Dec. 21, 2020@BNL)

- Ambient T: 19.8 °C
- Coolant T: 22.2 °C

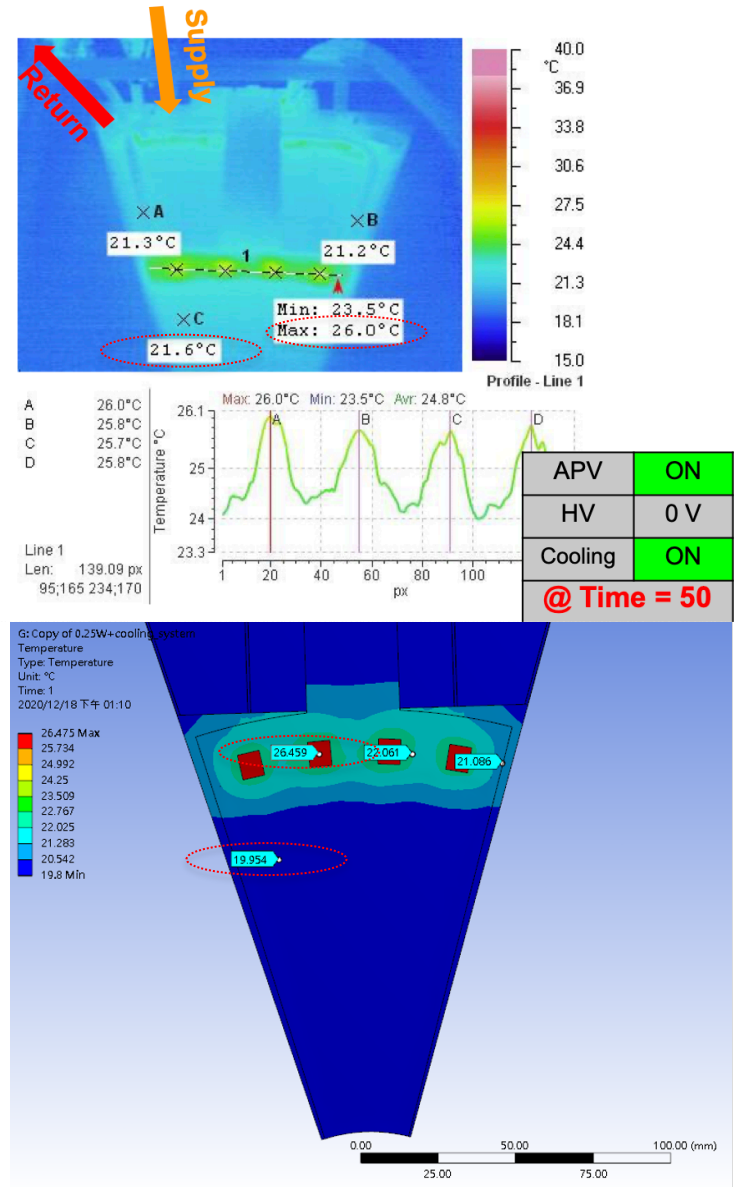
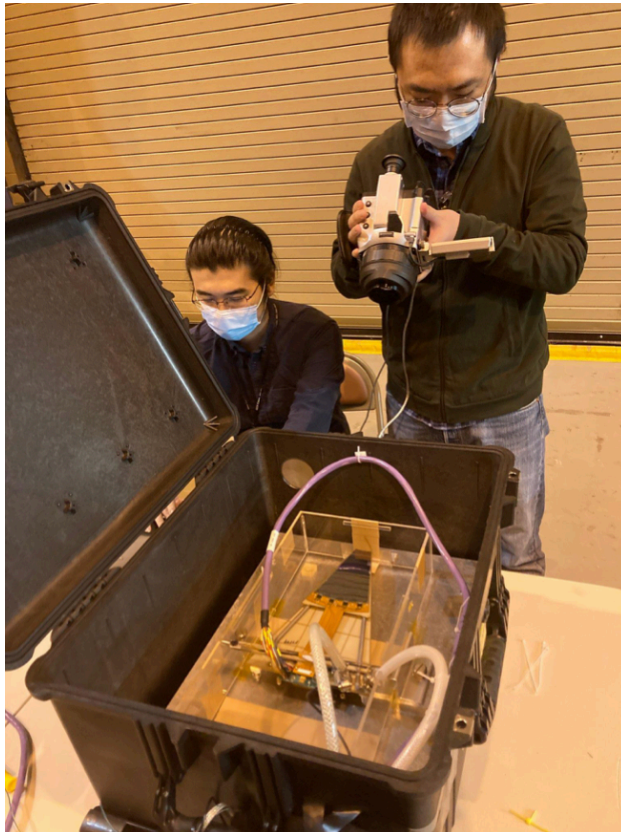

- Connect 3 wedges to be 1 set
- ➔ Total 4 in and 4 out for one disk

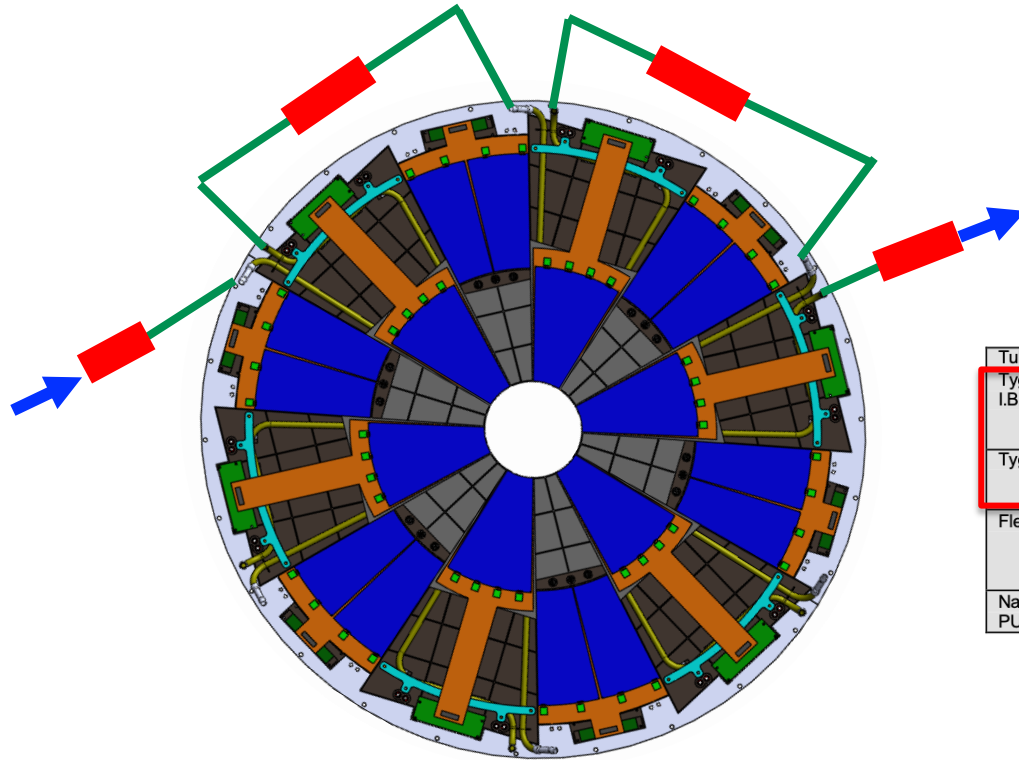

Plan A: plastic soft tube

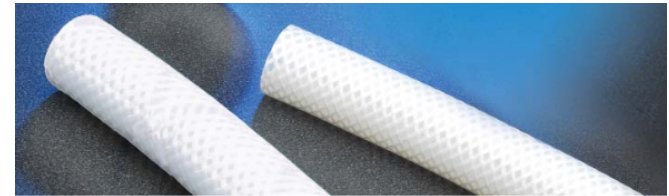

Recommended Flex Hoses for General Use

Tubing Name	Type	Extraction %	Weight gain %	Comments
Tygon™ C-544-A I.B.	Clear Braided Polyurethane	0.09	0.3	Excellent Compatibility. Good pressure resistance. Temperature Range -73 to 82C. www.tygon.com
Tygon 3370 I.B.	Clear Braided Silicone	1.47	4.8	Good Compatibility. Good Pressure resistance. Temperature Range -73 to 160C.
Flexfab™ 5521-050	Green braided silicone hose	2.08	NA	Good Compatibility. Good Pressure resistance. Temperature range -54 to 150C. http://www.flexfab.com
Nalgene™ 290 PUR	Clear Yellow. No Braid.	0.74	0.3	Excellent Compatibility. Little pressure resistance.

Plan B: metal soft/hard tube

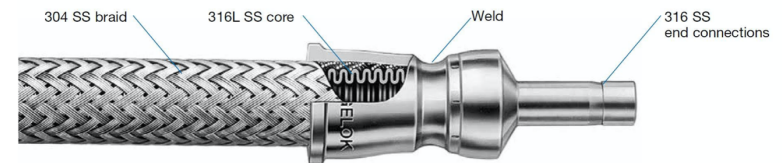

— Soft tubes
 ■ Connector

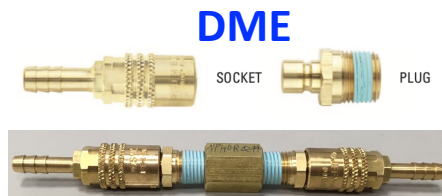

☐ Use the Soxhlet extraction method (suggested by 3M)

➔ C-544 is stable after 24 hours test

➔ 3370 is stable after 8 hours test

☐ Use Co⁶⁰ source at Institute of Nuclear Energy Research (INER)

☐ Two dosages:

■ 3.2 kGy (from proposal)

■ 16 kGy (5 times higher)

➔ No significant change before/after radiation

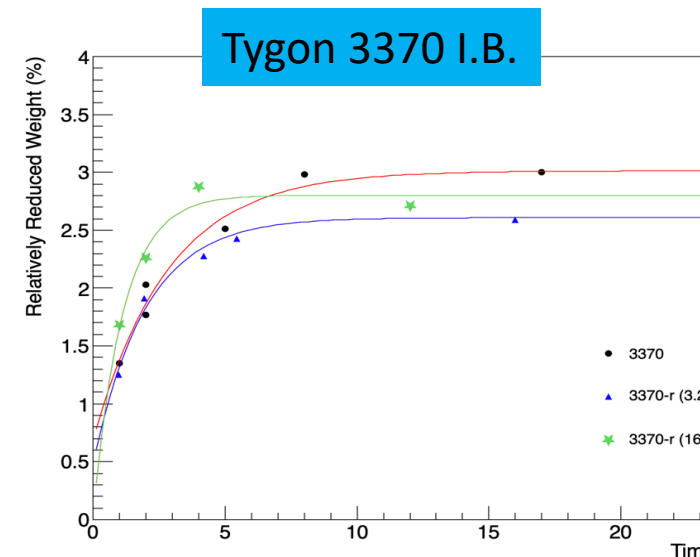
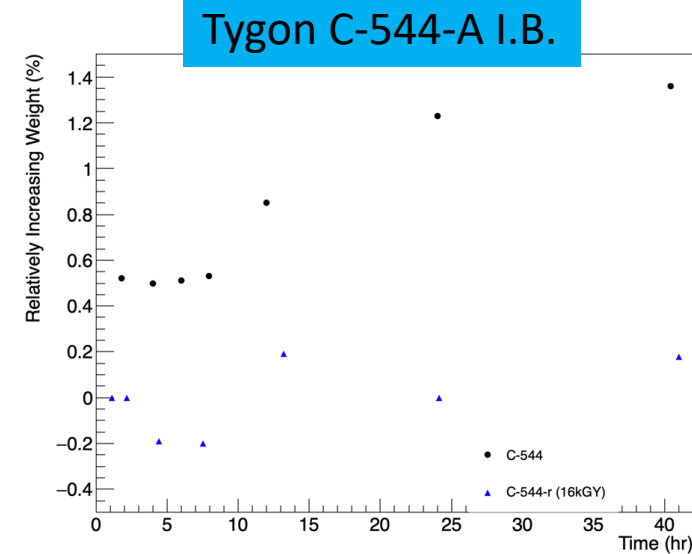
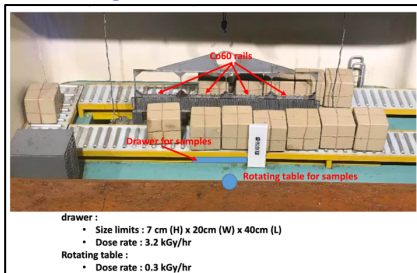

Burst Test on Soft Tubes

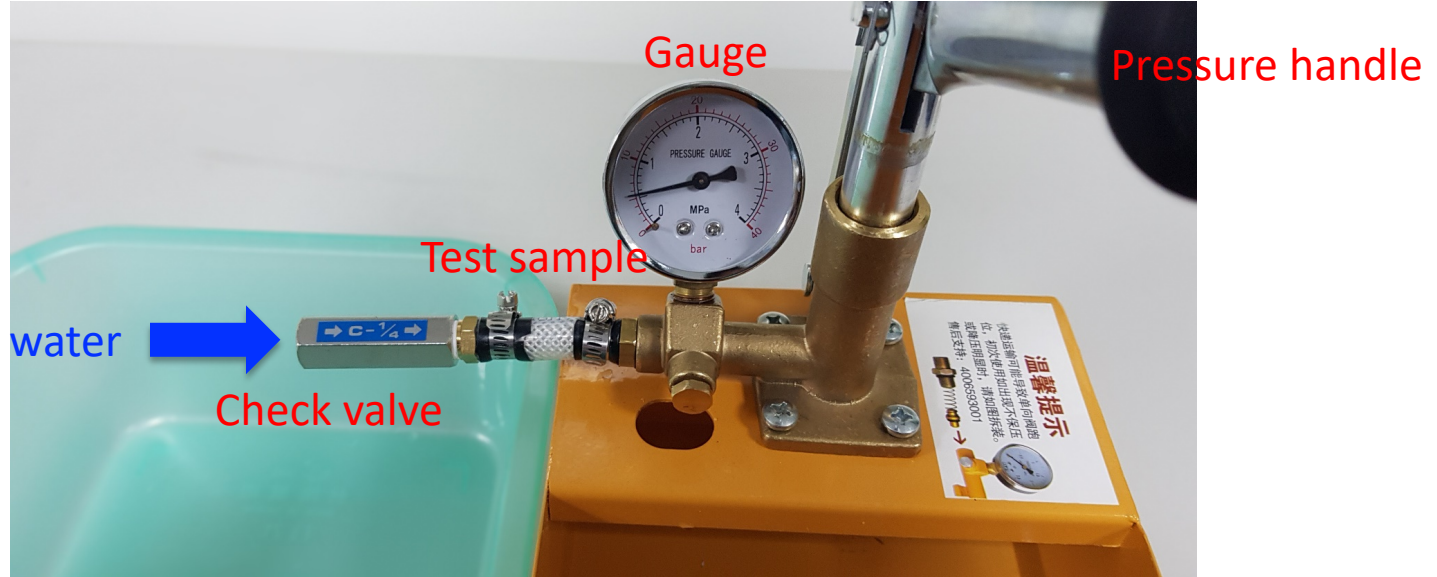

3370: 0 kGy

3.2 MPa → 1 MPa

C-544: 3.2 kGy

4 MPa



Deformation Pressure

Radiation dosage	3370	C-544
16 kGy	2.0 MPa	> 4 MPa
3.2 kGy	2.5 MPa	> 4 MPa
0 kGy	3.2 MPa	> 4 MPa



Summary



- QA plan is well defined
- Production is running smoothly: 5 modules/week



Backup





Flatness Issue on Main Structure

□ Timeline:

- **2019-Nov:** produced 1st (PEEK+30% CF) and 2nd (PEEK+30% GF) prototype
→ Obvious flatness issue
- **2019-Dec:** modified the design due to the change of the positions of APV chips and produce 3rd prototype
→ Flatness issue is not solved
- **2020-Jan:** increased the thickness from 1.5 mm to 2.0 mm + changed the injection points from side to center
→ Flatness issue is not solved
- **2020-Feb:** use pure PEEK + extra cooling on molds
→ Flatness is significantly improved, but not 100% solved
- **2020-May:** use rigid quality control selections
→ Flatness improved (solved)

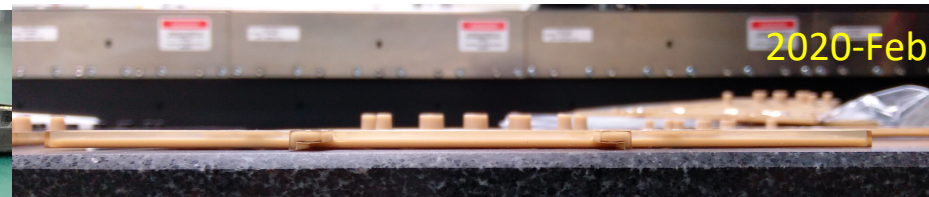
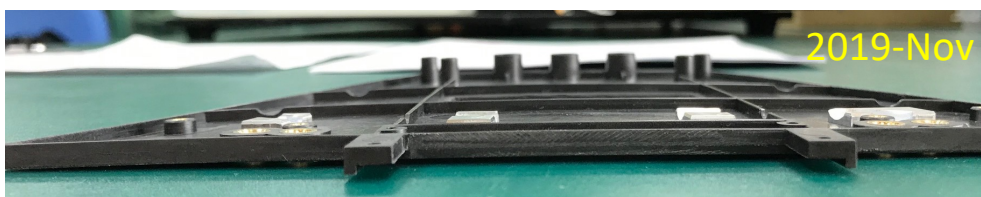

Prototypes: FST-001, FST-002

- Goal: quickly produced prototypes for sensor testing
- Many issues found: flatness, bubbles, shifting...

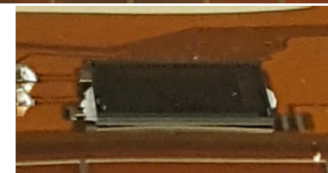
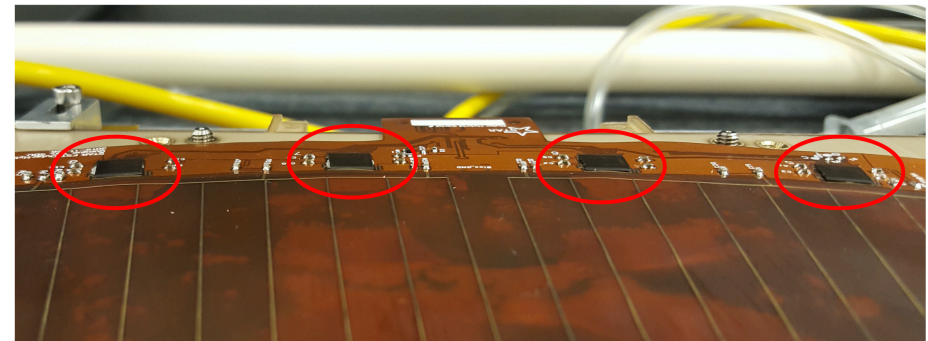
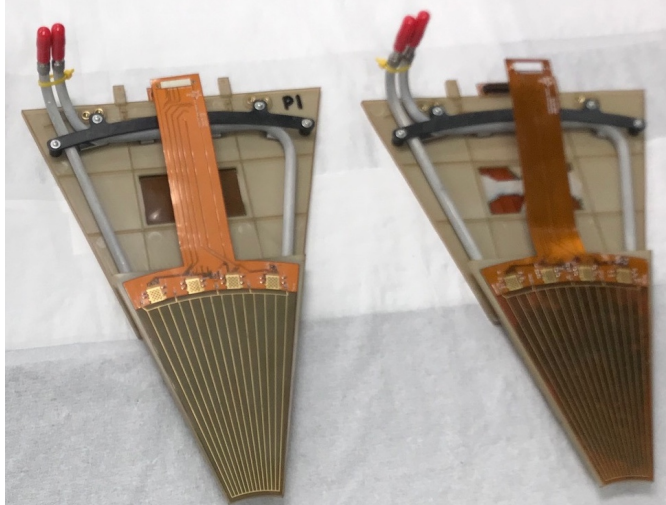
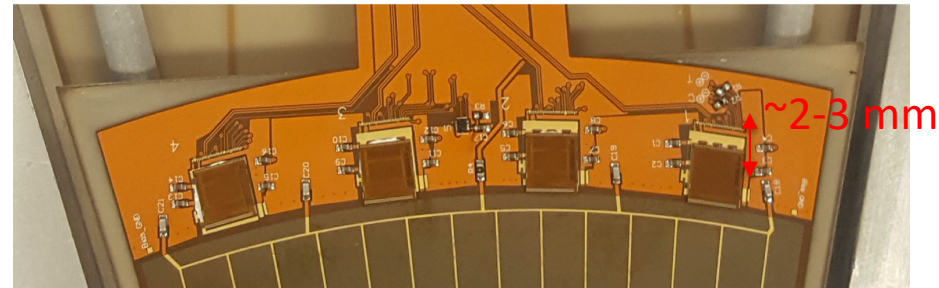
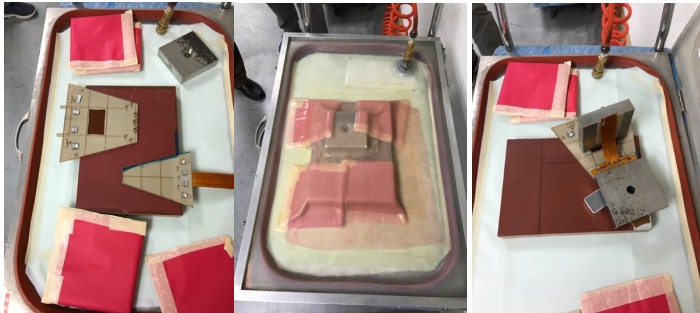

Flatness (RMS)	Thicker hybrid	Thinner hybrid
Inner	0.2942 (mm)	0.2663 (mm)
Outer	0.4654 (mm)	0.2585 (mm)

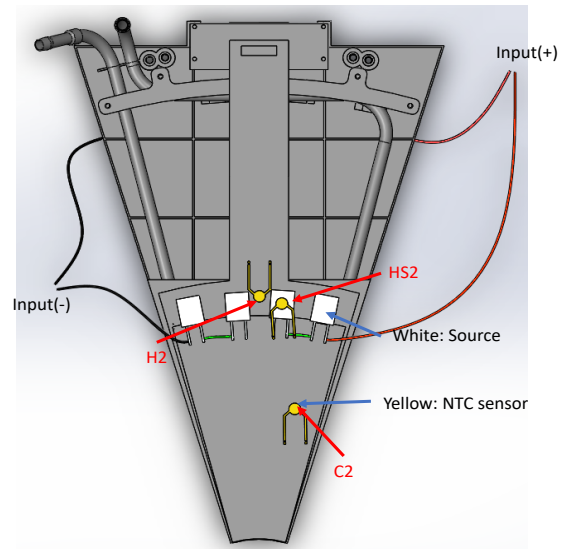
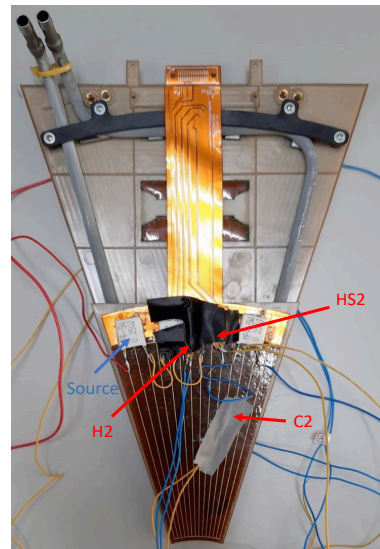
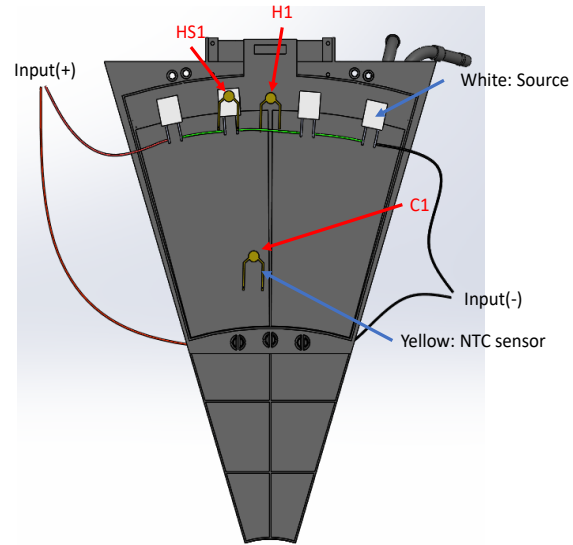
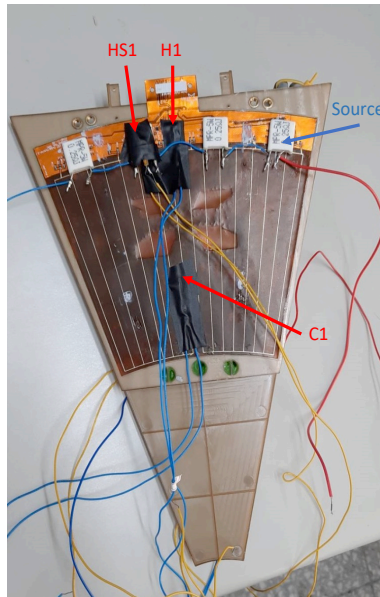



Quality Assurance: Outer



- Use OGP to measure the flatness
 - 5 points at chip areas and 9 points at sensor area
 - Distances from guide pins to reference points (in x and y)

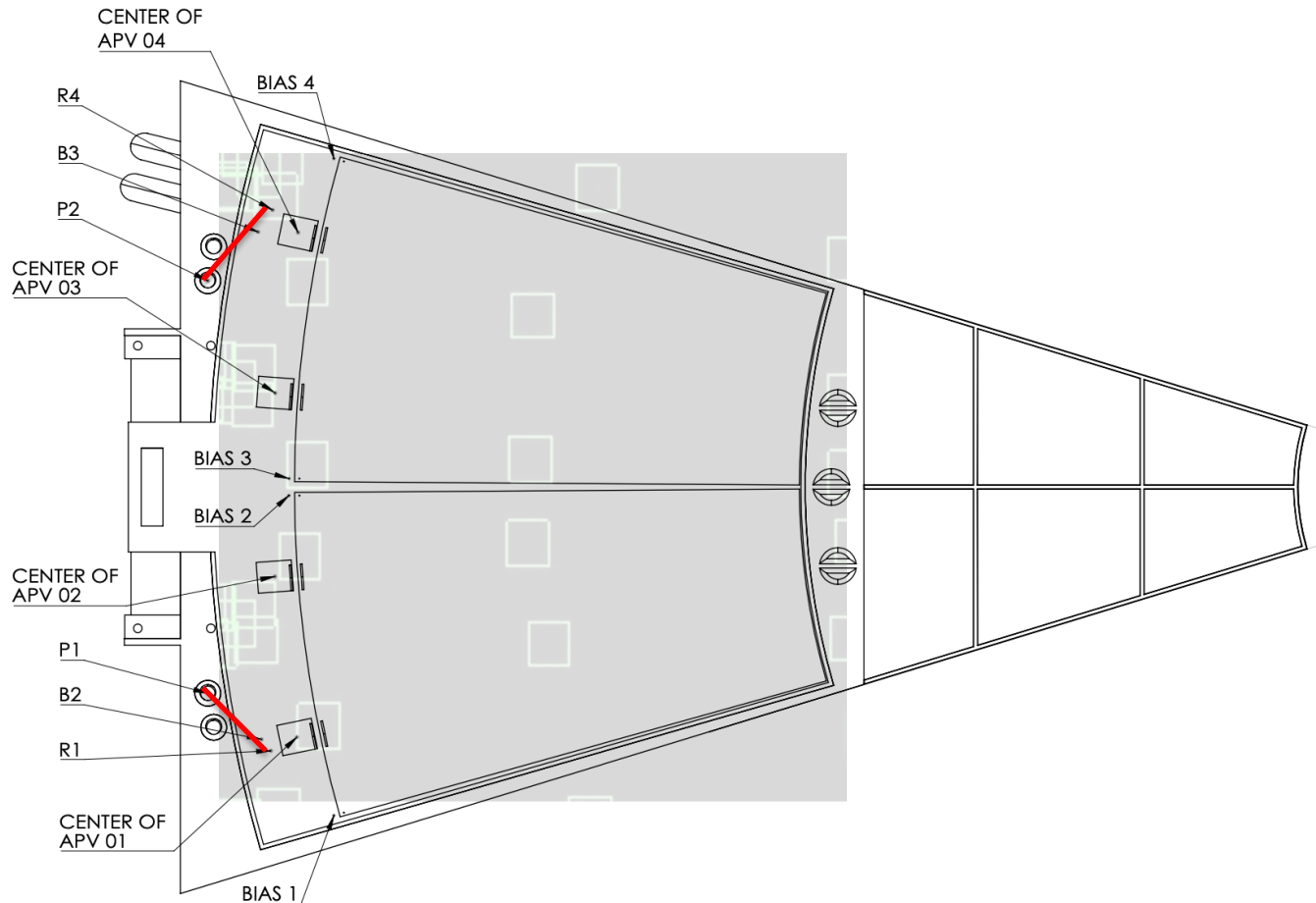

Quality Assurance: Inner

- Use OGP to measure the flatness
 - 5 points at chip areas and 9 points at sensor area
 - Distances from guide pins to reference points (in x and y)

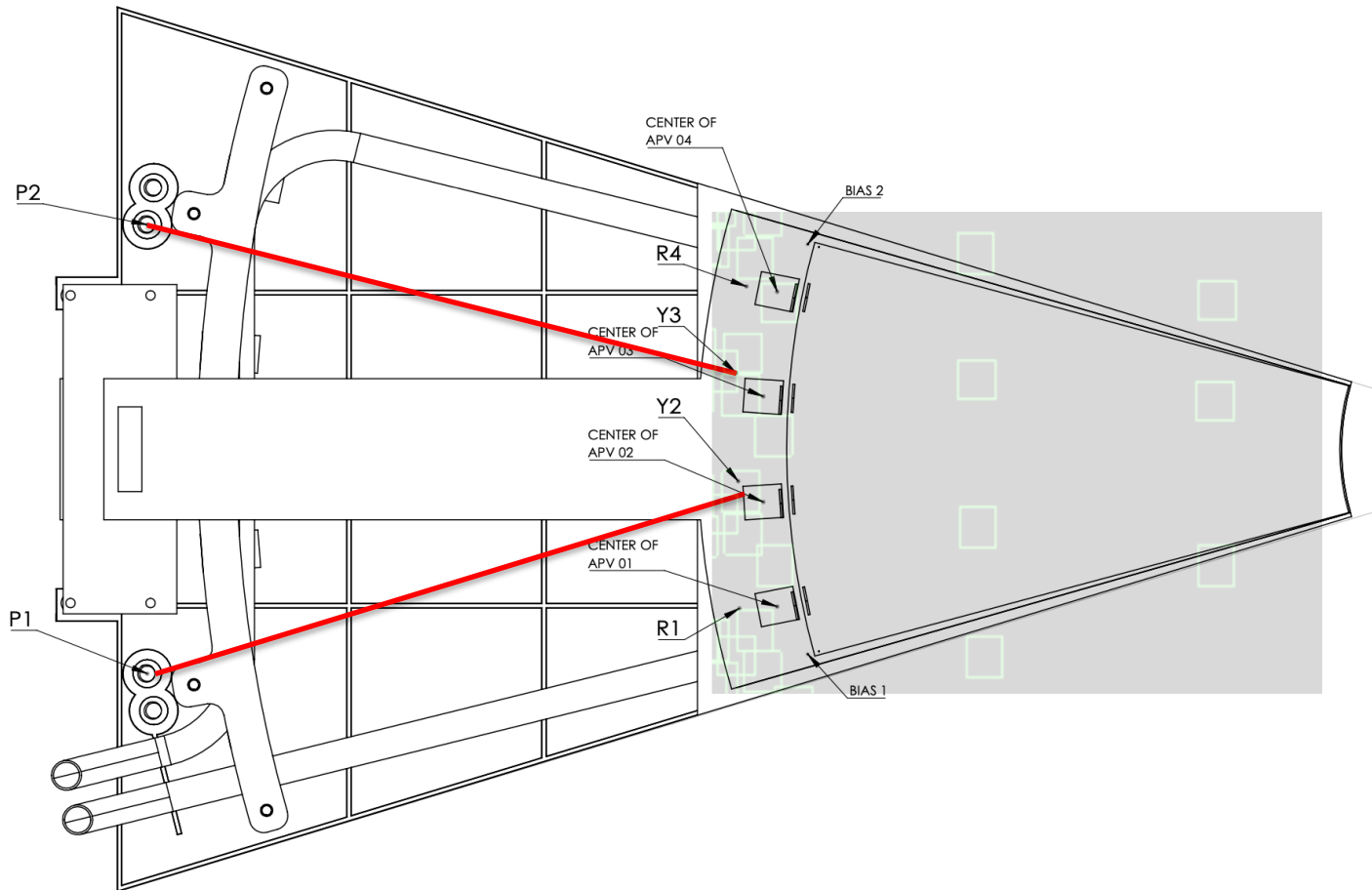

Measurements: Inner

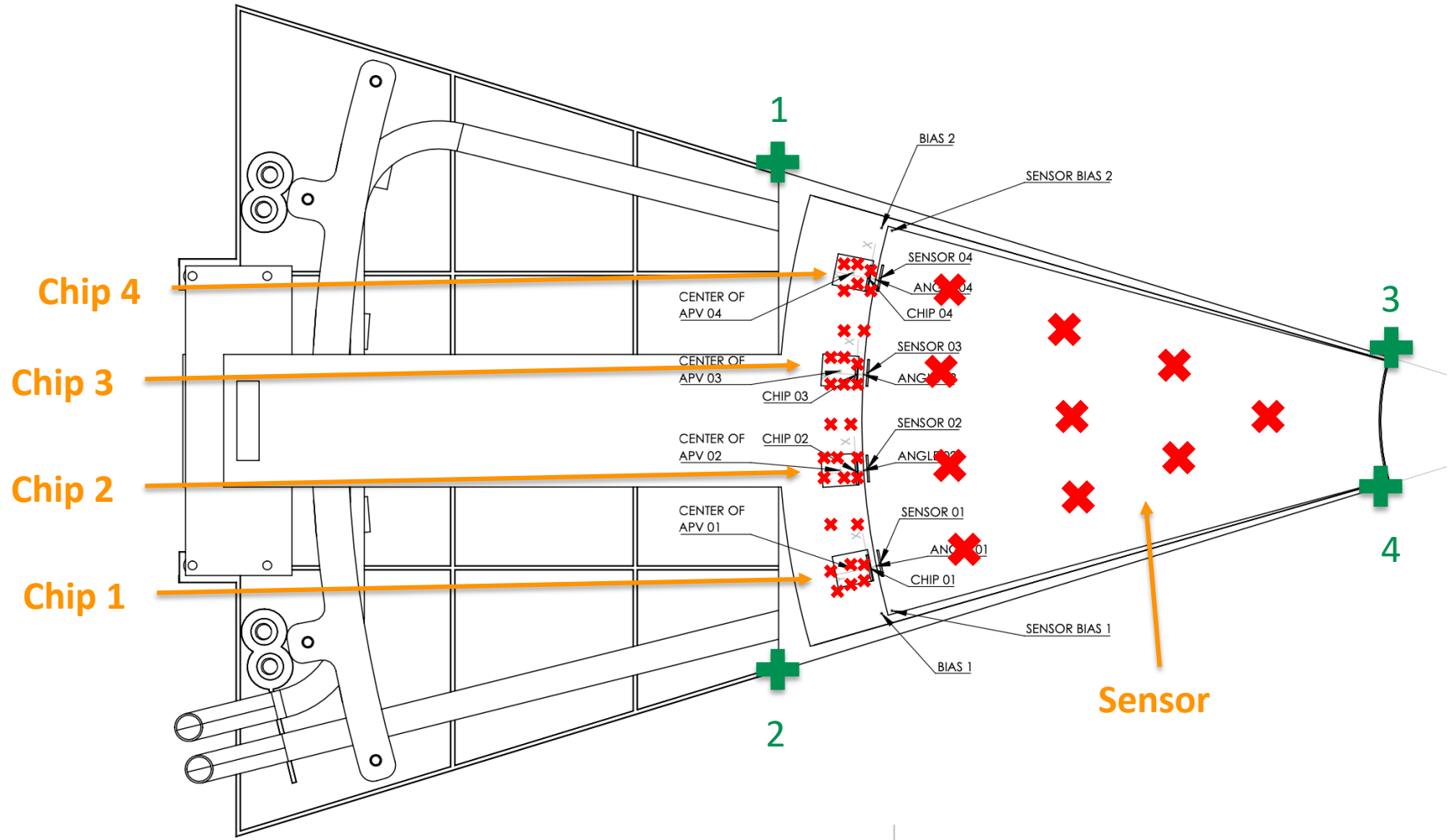



Inner: Dimension



Unit: mm

	Part	D12	δ D12	D13	δ D13	D24	δ D24	D34	δ D34
Solidworks	 	113.13	 	144.46	 	144.46	 	28.66	
Inner	1	112.785	0.345	144.03	0.43	144.049	0.411	28.497	0.163
	2	112.796	0.334	144.018	0.442	144.05	0.41	28.472	0.188
	3	112.783	0.347	144.014	0.446	144.046	0.414	28.451	0.209
	4	112.698	0.432	143.996	0.464	143.942	0.518	28.493	0.167
	5	112.775	0.355	143.953	0.507	144.077	0.383	28.503	0.157
	6	112.787	0.343	143.956	0.504	144.076	0.384	28.51	0.15
	7	112.771	0.359	144.001	0.459	144.045	0.415	28.479	0.181
	8	112.738	0.392	143.942	0.518	143.996	0.464	28.44	0.22
	9	112.704	0.426	143.998	0.462	144.043	0.417	28.458	0.202
	10	112.789	0.341	144.025	0.435	144.08	0.38	28.484	0.176



Inner: Flatness

- Unit: μm
- Flatness: maximum difference between measured points

	Part	Chip 1	Chip 2	Chip 3	Chip 4	Sensor
Inner	1	73.2	25.8	40.7	84.2	484.4
	2	129.7	55.3	69.6	144	397.2
	3	136.3	38.6	27.7	101.5	182.7
	4	30.5	52.5	39.4	59.3	815.8
	5	172.8	76.4	47.7	48.4	574.4
	6	167.2	74.7	46.1	54.6	545.2
	7	137.9	66.1	71.1	159.2	313.3
	8	112.8	58.2	57.5	33.6	483
	9	157.7	92.9	93.1	174.7	158.6
	10	23.6	50	85.6	176	887.7



Plan for the Measurements: Outer

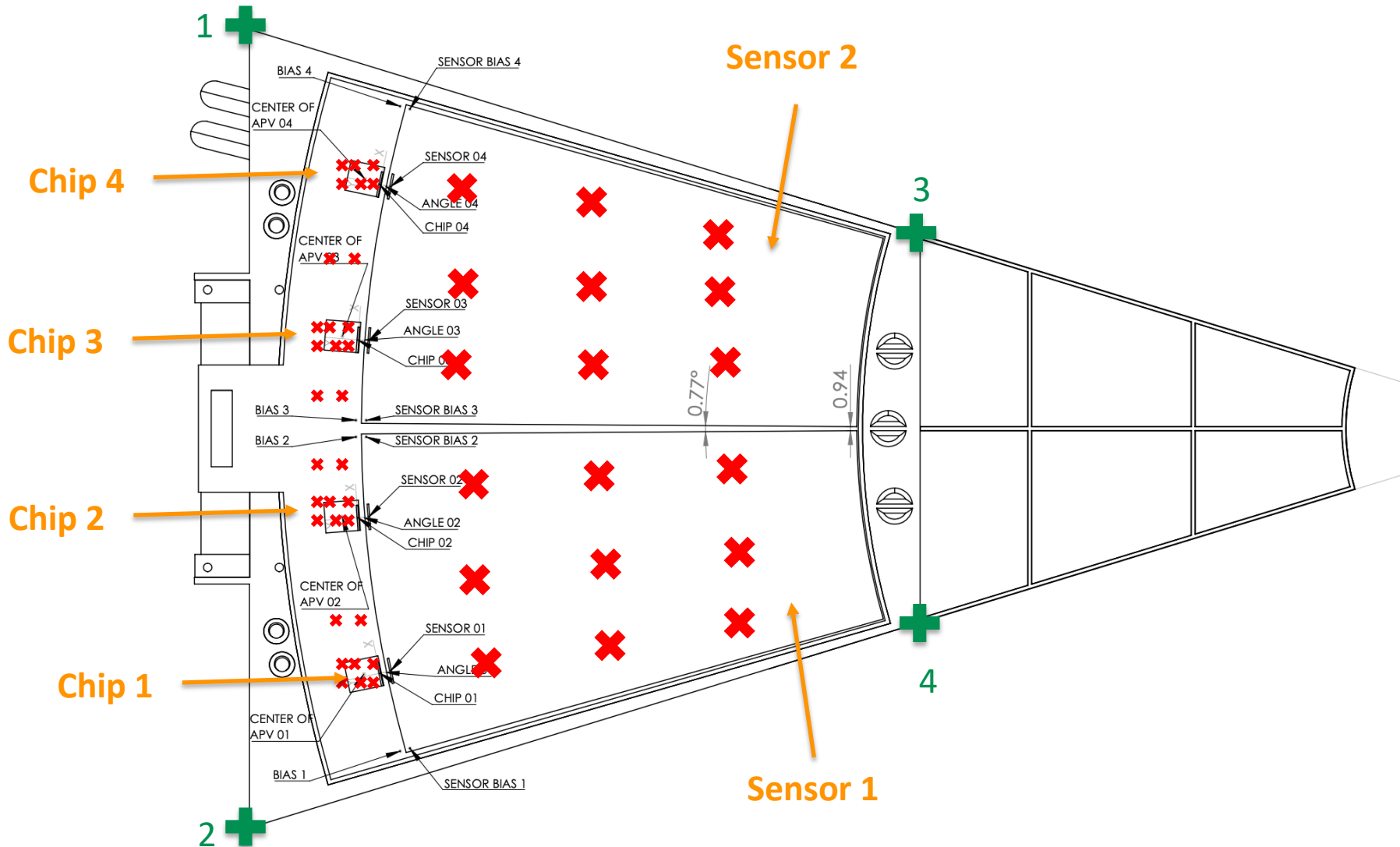



Outer: Dimension

Unit: mm

	Part	D12	δ D12	D13	δ D13	D24	δ D24	D34	δ D34
Solidworks		188.09		165.39		165.39		91.38	
Inner	1	187.585	0.505	164.882	0.508	164.93	0.46	91.183	0.197
	2	187.603	0.487	164.895	0.495	164.927	0.463	91.199	0.181
	3	187.62	0.47	164.87	0.52	164.878	0.512	91.228	0.152
	4	187.582	0.508	164.879	0.511	164.867	0.523	91.176	0.204
	5	187.598	0.492	164.899	0.491	164.916	0.474	91.2	0.18
	6	187.584	0.506	164.864	0.526	164.943	0.447	91.155	0.225
	7	187.577	0.513	164.896	0.494	164.922	0.468	91.19	0.19
	8	187.551	0.539	164.81	0.58	164.865	0.525	91.093	0.287
	9	187.518	0.572	164.837	0.553	164.899	0.491	91.141	0.239
	10								



Outer: Flatness

- Unit: μm
- Flatness: maximum difference between measured points

	Part	Chip 1	Chip 2	Chip 3	Chip 4	Sensor 1	Sensor 2
Inner	1	92.4	62.8	87.4	117.2	346.6	415.5
	2	114.1	72.3	43.1	69.7	291.3	434
	3	90.2	33.5	56.1	41.5	319.5	365.6
	4	78.1	40.8	39.4	45.8	144.4	129.2
	5	37.2	20.7	36.1	59.5	254.3	241.4
	6	80.6	43.4	80.7	112.4	444.5	418.4
	7	63.1	45.8	28.3	60	199	135.8
	8	85.3	36.3	53.3	112.8	293	391.8
	9	74.1	29.8	76.7	158.8	340.5	240
	10						



Final QA



- Outsource (Taiwan CK Techno Co.,Ltd.) the measurements of flatness and parallelism (800 USD per module)

量測報告

CK20094

報告編號: CK20094
 品名: FST_single_module_outer_1102
 客戶: 國立成功大學 物理學系
 樣品數: 1 pcs
 量測日期: 2020/7/16~25
 量測員: David
 確認者: Henry

溫度°C	溼度%
20.9	49.3
20.9	54.2
儀器編號	
-	-
QT0180	-

註記: (1) -
 (2) -

UNIT: mm/°

CK20094

位置	項目	檢查工具	-1				
A	平面度	CMM	0.535				
A1	平面度	CMM	0.072				
A2	平面度	CMM	0.018				
A3	平面度	CMM	0.108				
A4	平面度	CMM	0.008				
AA	平面度	CMM	0.633				
B	平面度	CMM	0.122				
B1	平面度	CMM	0.070				
B2	平面度	CMM	0.054				
B3	平面度	CMM	0.012				
B4	平面度	CMM	0.012				
BB	平面度	CMM	0.297				
C	平行度	CMM	1.457				
D	平行度	CMM	1.501				
Blank							

測試方法: 依據 T-511(R4)、512(R2) 社內指導文件執行。

- 說明:
1. 認證範圍外的項目以 "***" 註記
 2. 不確定度評估方法參考 ISO Guide 98-3 「量測不確定度表示法指引」執行。
 3. 量測能力係以95%信賴水準 · k=2擴充不確定度表示。
 4. Uncertainty = 7.3 μm
 5. 量測追溯:

儀器編號	儀器名稱 / 型號	序號	校正報告	校正日期
QT0180	CMM / BND-CC9108	0096601	L-IR-108-05-510	2019/05/28
【CMM】三次元座標量測儀				

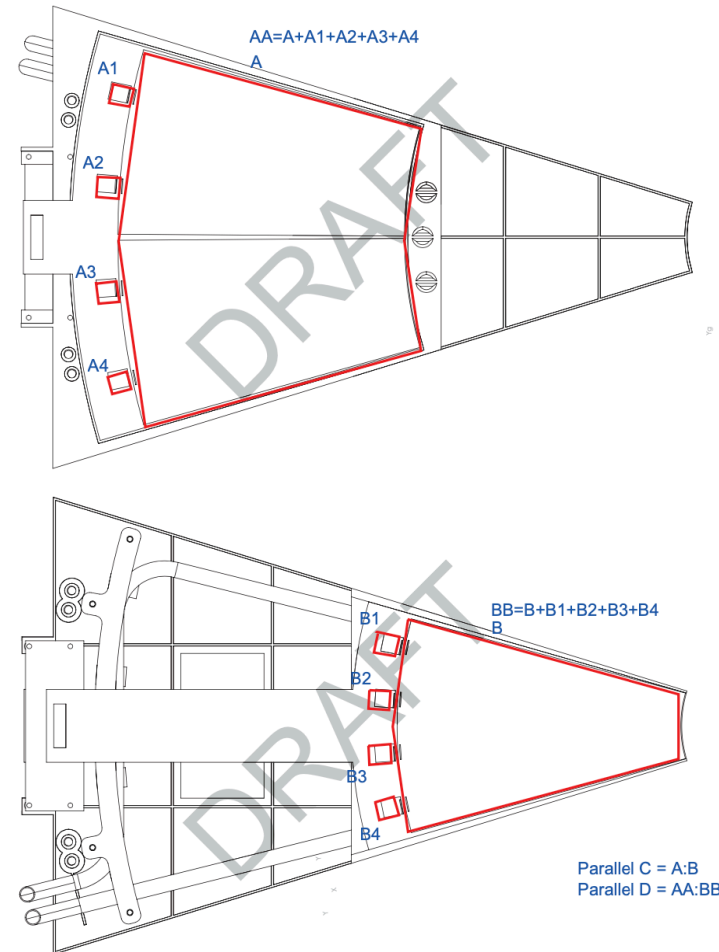



Plan for the Measurements



- ❑ Plan to outsource (Taiwan CK Techno Co.,Ltd.) the measurements of flatness and parallelism
- ❑ Extremely expensive:
 - **Flatness** for single inner or outer MS (before assembly):
 - ❑ Price: **~200 USD/pc**
 - ❑ Method: optical
 - **Flatness and parallelism** for assembled module:
 - ❑ Price: **~400 USD/pc**
 - ❑ Method: mechanical (their know-how)
- ➔ Total of 60 sets: **48,000 USD** **Working on getting a better deal**

- ❑ Plan for the prototypes:
 - **Flatness** for single inner or outer MS (before assembly) at TiDC
 - **Flatness and parallelism** for assembled module (first 10) by CK Techno



Production time for single module

- ❑ **Day 1 - Day 10:** preparation (QC for 200 sets)
- ❑ **Day 11:** mount Outer Hybrid to MS (FST_prod_001)
- ❑ **Day 12:** assembly Outer Wedge and Inner MS (FST_prod_001)
mount Outer Hybrid to MS (FST_prod_002)
- ❑ **Day 13:** mount Inner Hybrid to inner MS (FST_prod_001)
assembly Outer Wedge and Inner Wedge (FST_prod_002)
mount Outer Hybrid to MS (FST_prod_003)
- ❑ **Day 14: Done (FST_prod_001)**
mount Inner Hybrid to inner MS (FST_prod_002)
assembly Outer Wedge and Inner Wedge (FST_prod_003)
mount Outer Hybrid to MS (FST_prod_004)
- ❑ **Day 15: Done (FST_prod_002)**
mount Inner Hybrid to inner MS (FST_prod_003)
assembly Outer Wedge and Inner Wedge (FST_prod_004)
mount Outer Hybrid to MS (FST_prod_005)
- ❑ ...
- ❑ **Day 72:** mount Inner Hybrid to inner MS (FST-prod_060)
- ❑ **Day 73: Done (FST_prod_060)**

One day per mouldle



Production Qualities: Class B

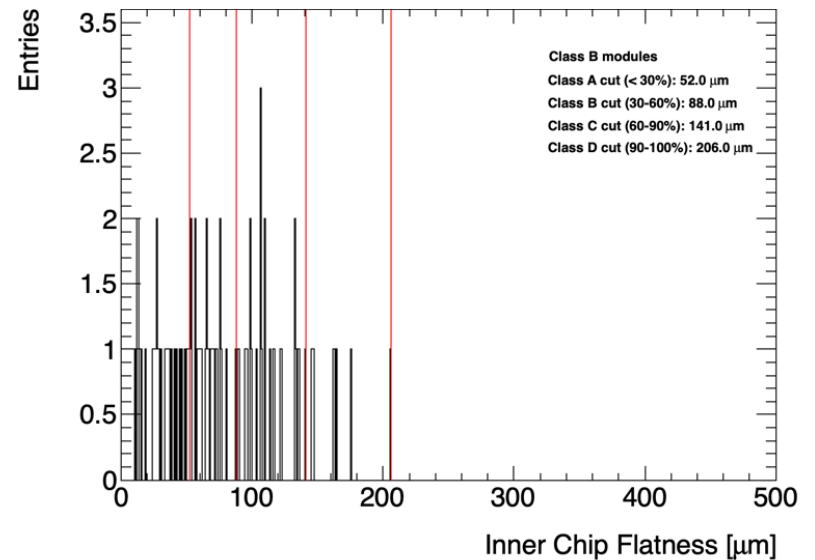
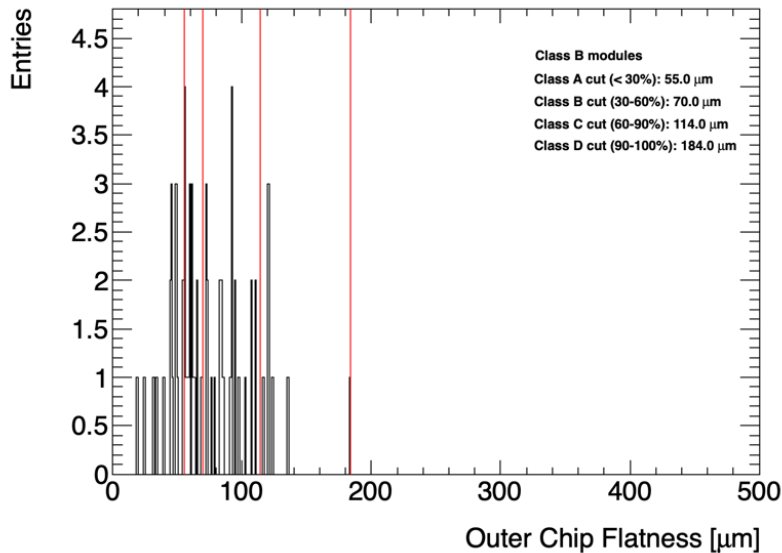
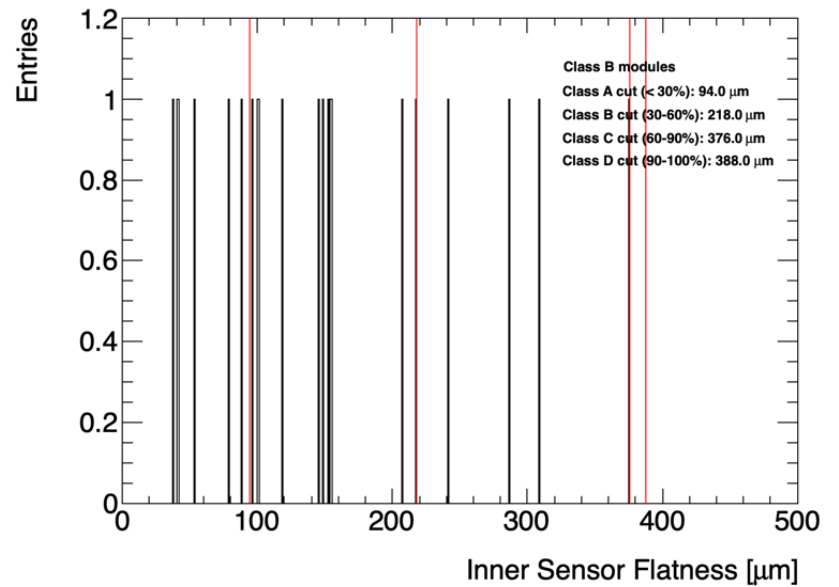
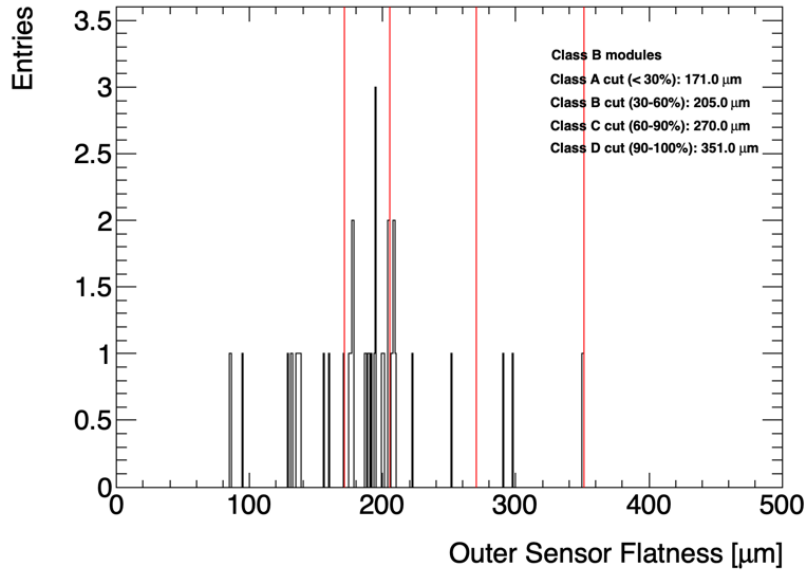



Production Qualities: Class B

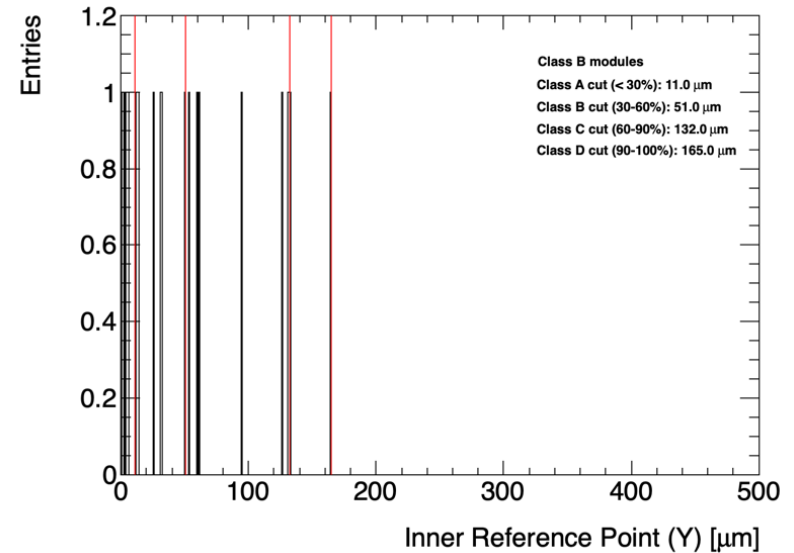
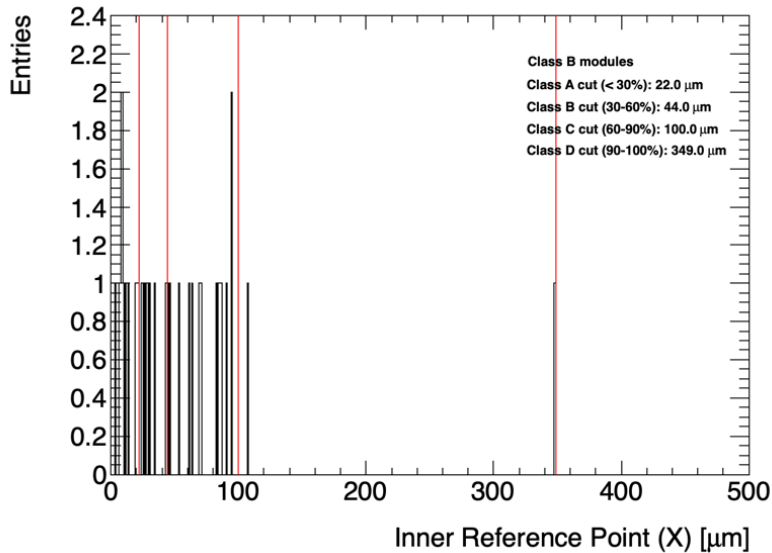
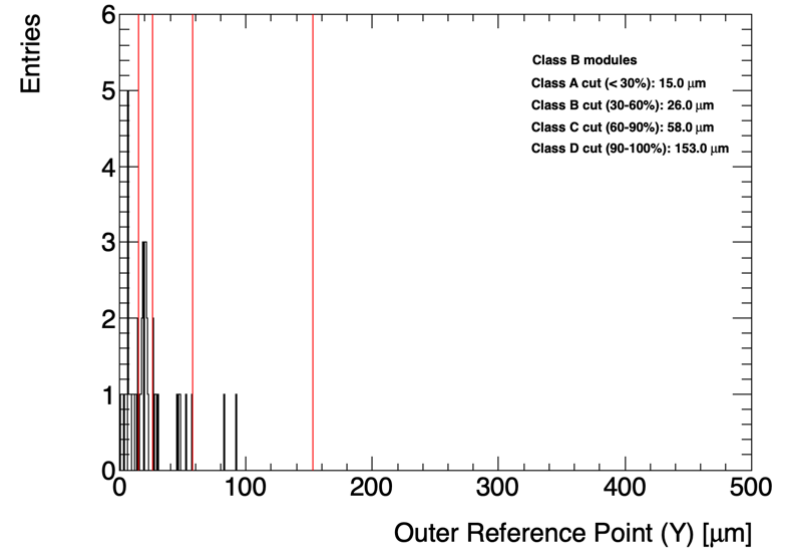
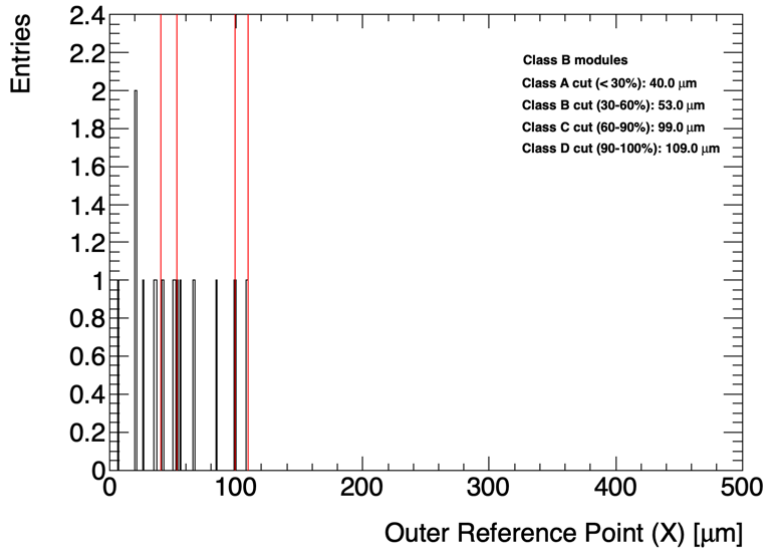



Production Qualities: Class C

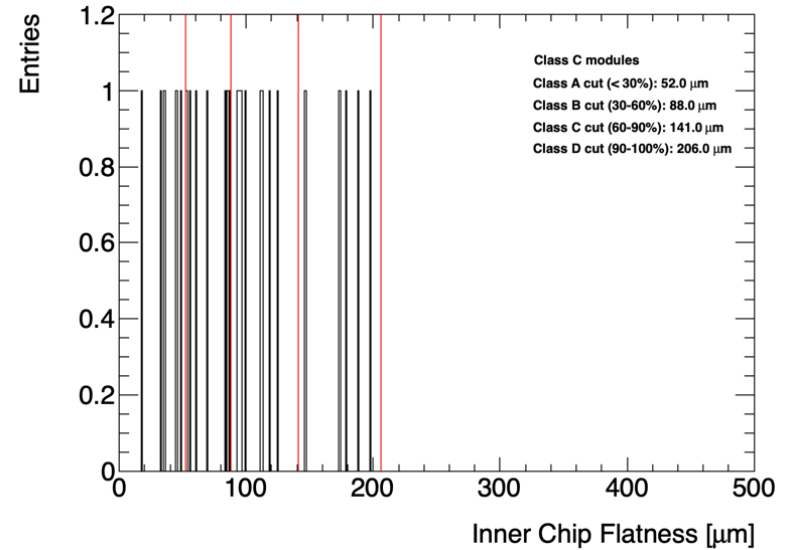
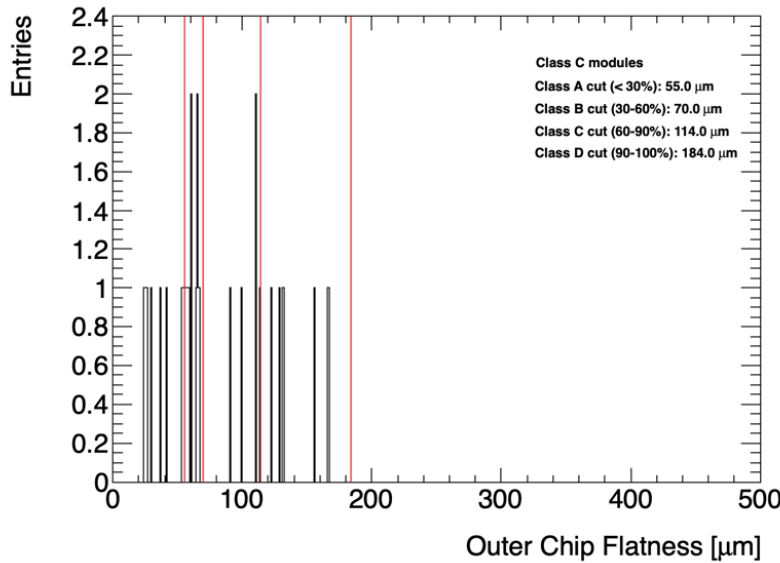
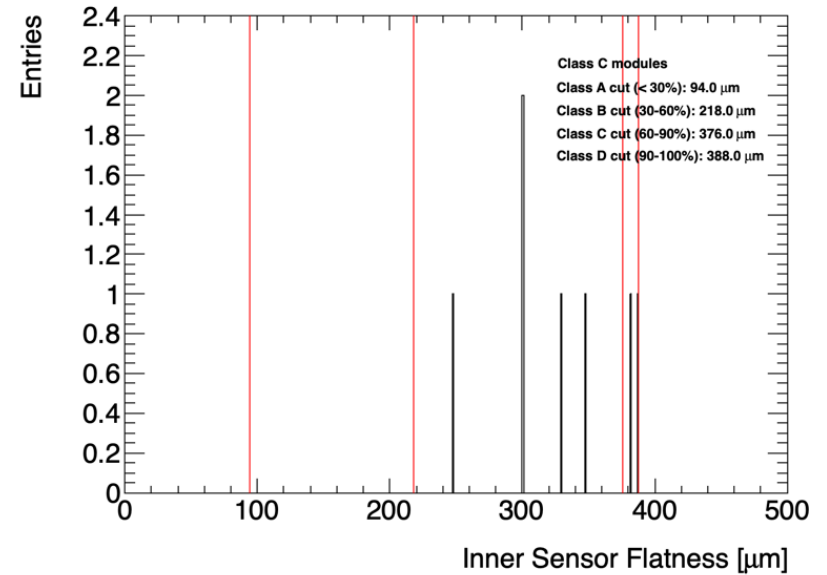
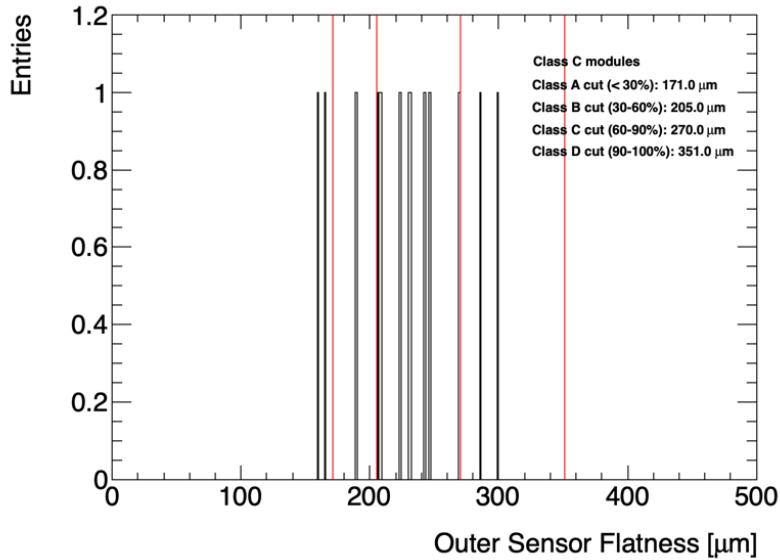



Production Qualities: Class C

