



HYBRID TRACKER REDESIGN

Nick Lukow on behalf of eRD6

August 17, 2021

ATHENA Tracking WG Meeting



Original Hybrid Baseline Configuration

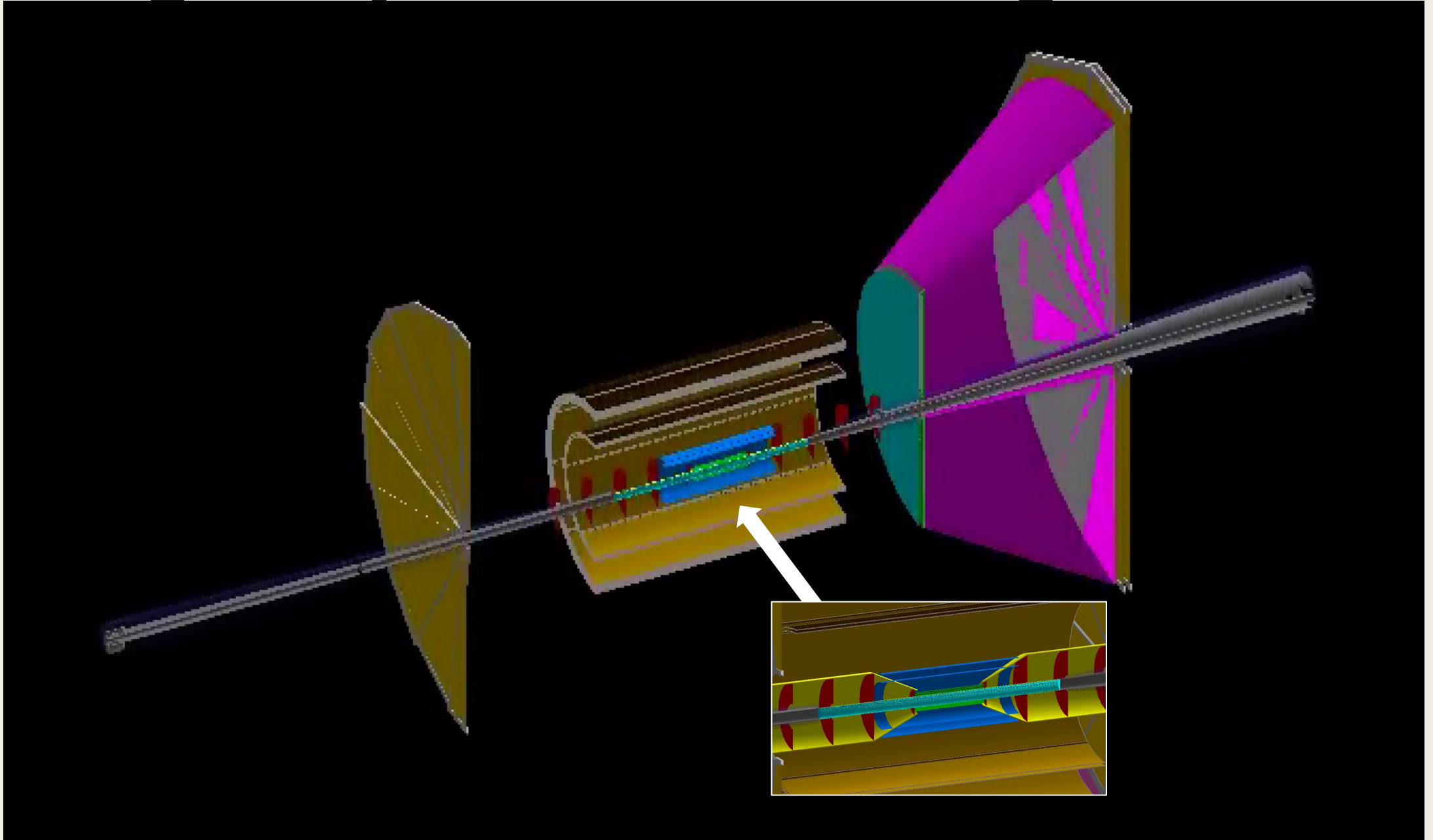

New Projective Hybrid Configuration

- New hybrid configuration designed to be projective with conical support/services along $\eta = \sim 1.1$ and ~ 2.5
 - Central detectors (not vertex tracker) were made projective along $\eta = \sim 1.1$
 - 3 projective inner GEM disks added on each side of the central detector
 - Removed outer rear GEM and one outer forward GEM disk

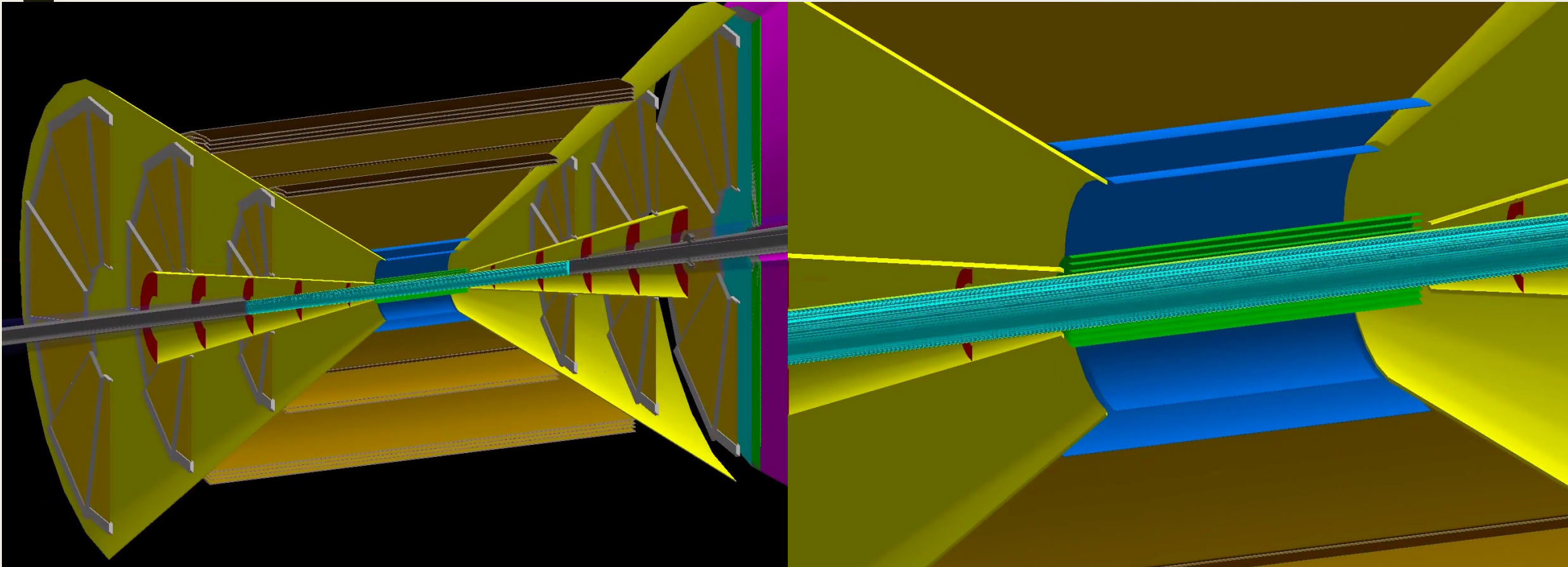
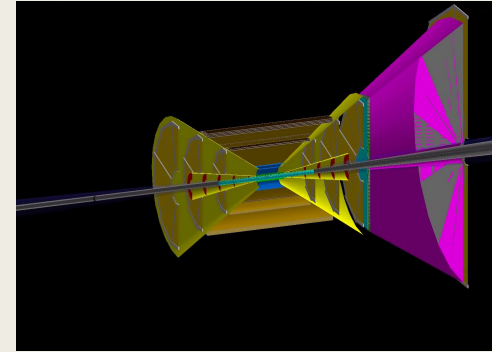

P Resolution vs P

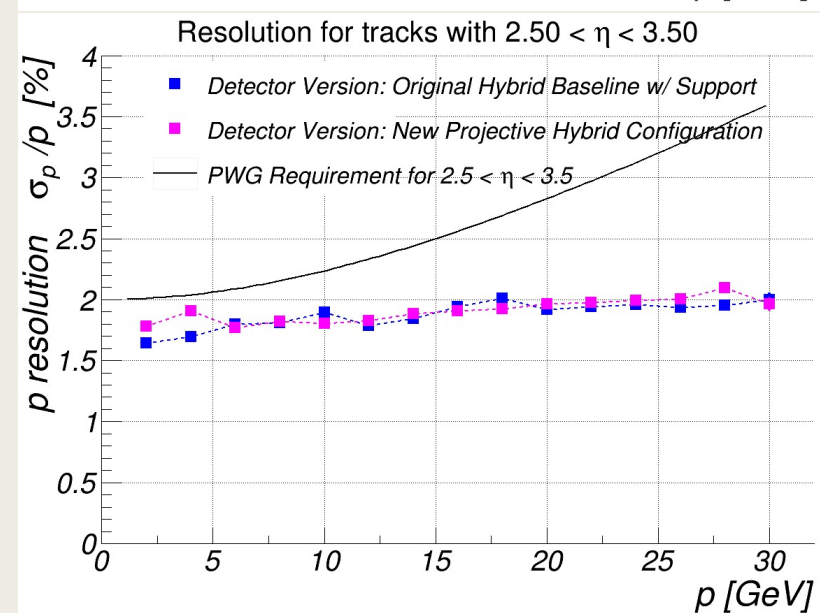
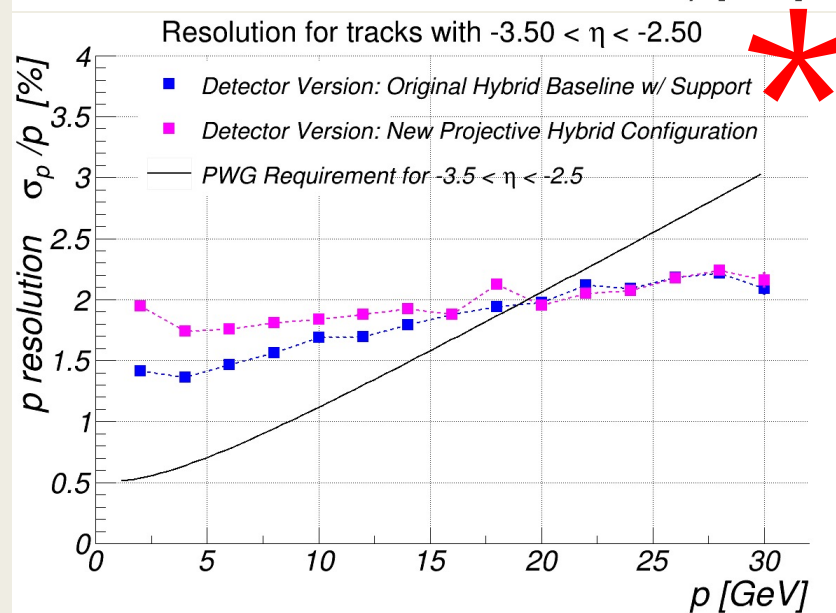
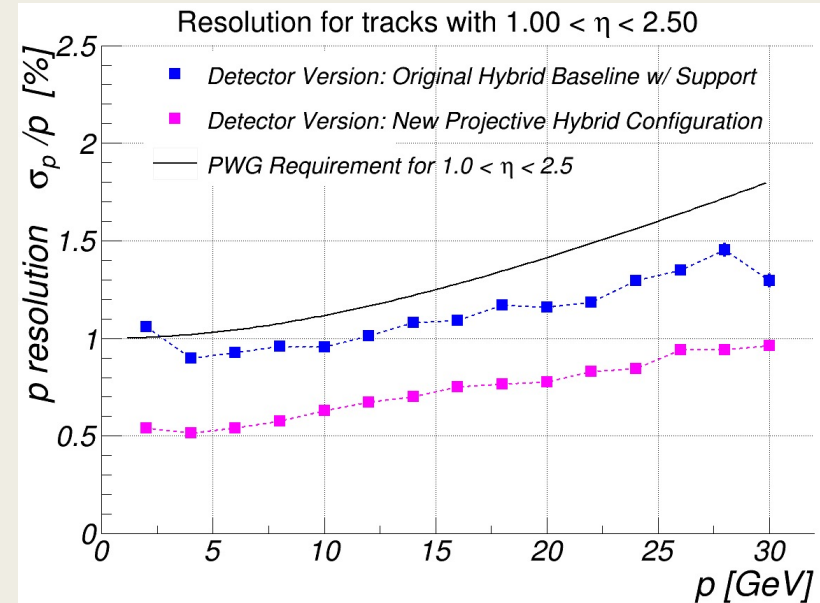
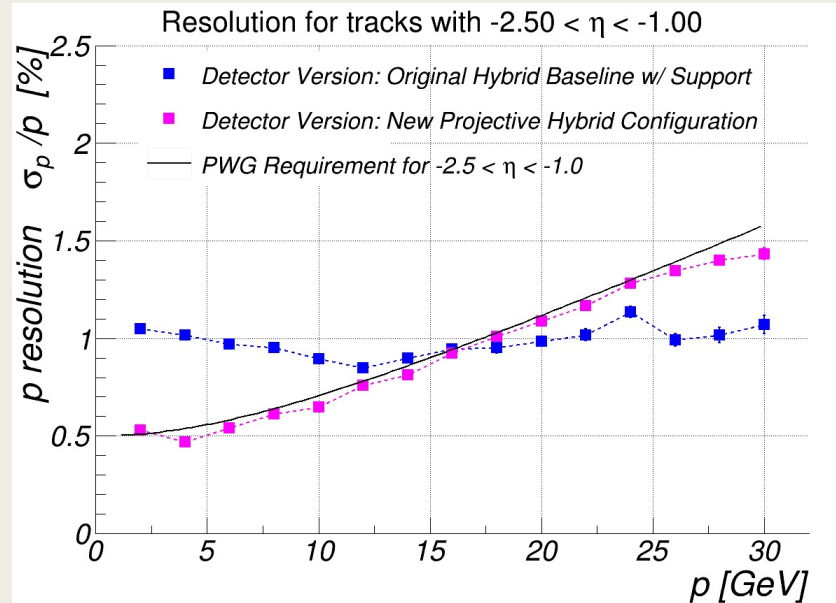

* Rear GEM disk at $z = -190$ plays significant role

Pt Resolution vs Pt

- Restricted to total momentum less than 30 GeV/c

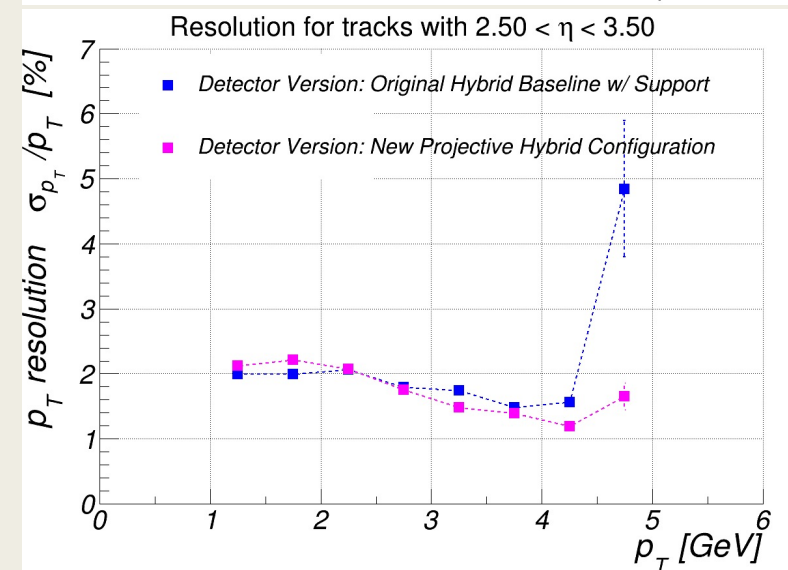
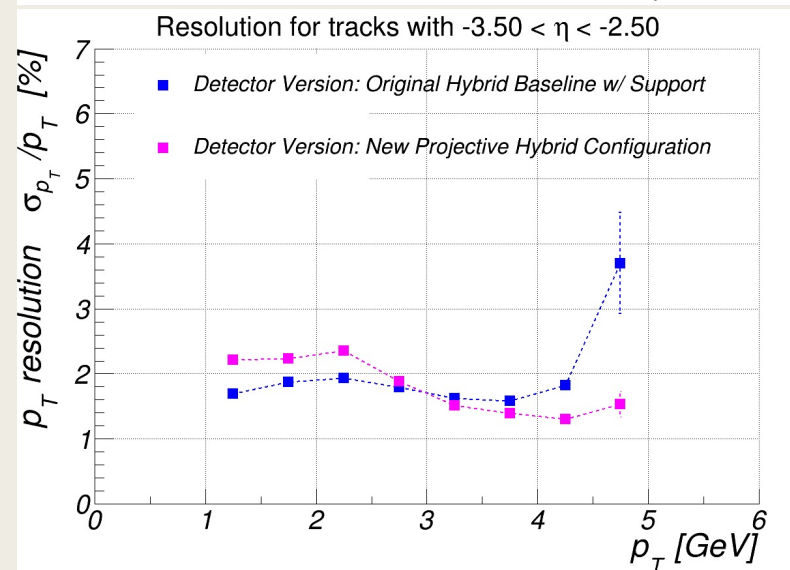
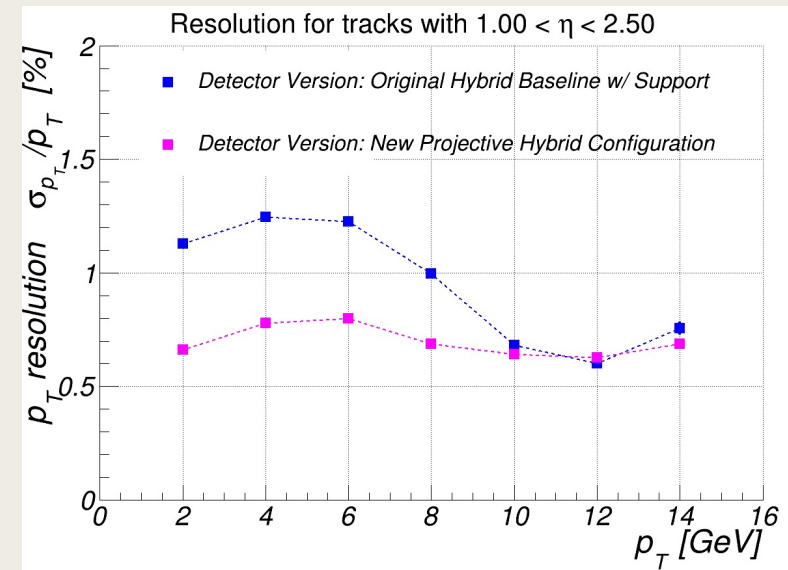
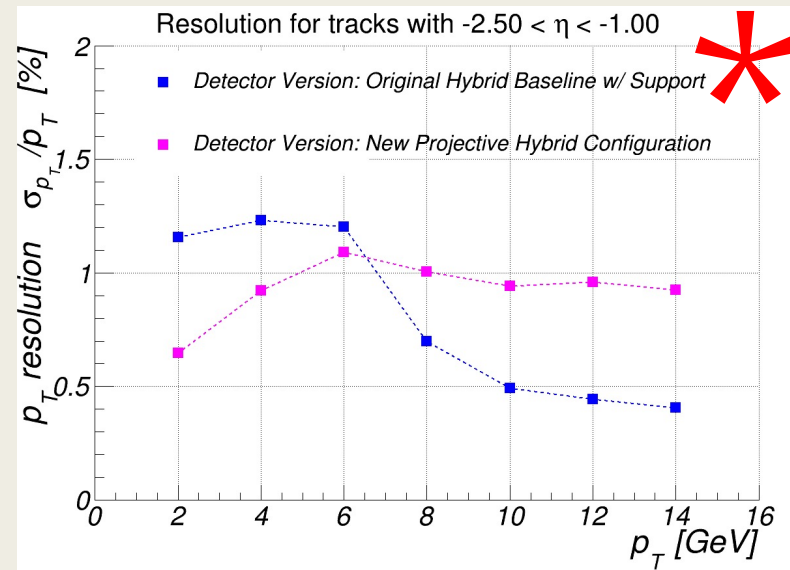

* Rear GEM disk at $z = -190$ plays significant role

mRICH Angular Resolution ($z = -146$ cm)

θ Resolutions

ϕ Resolutions

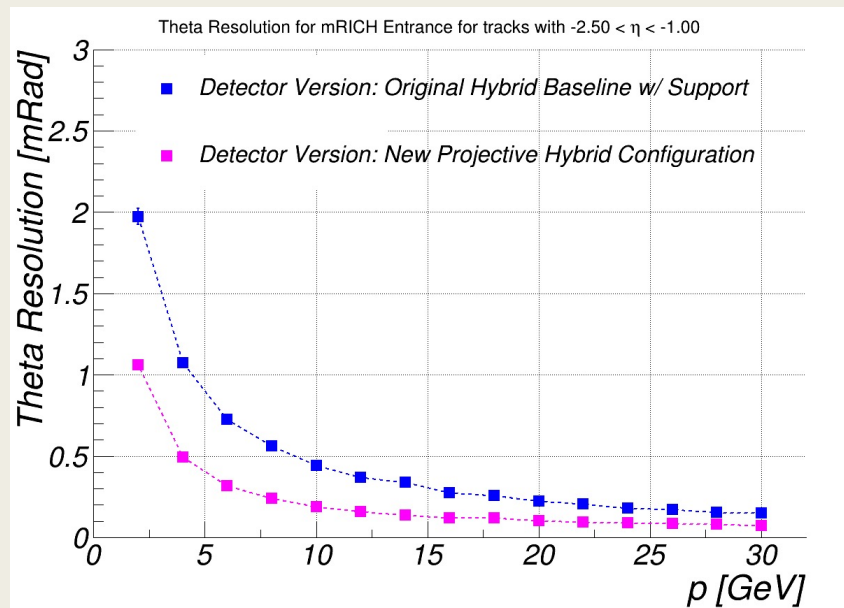

$-2.5 < \eta < -1.0$

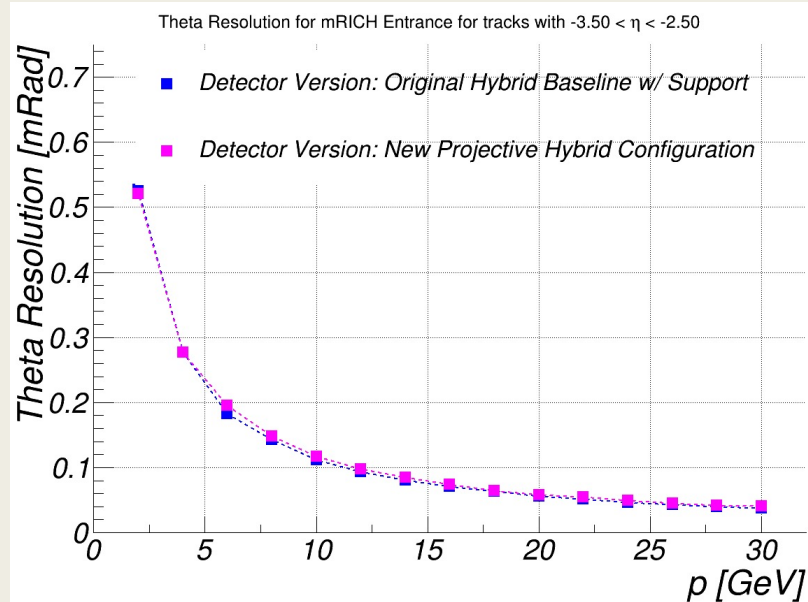
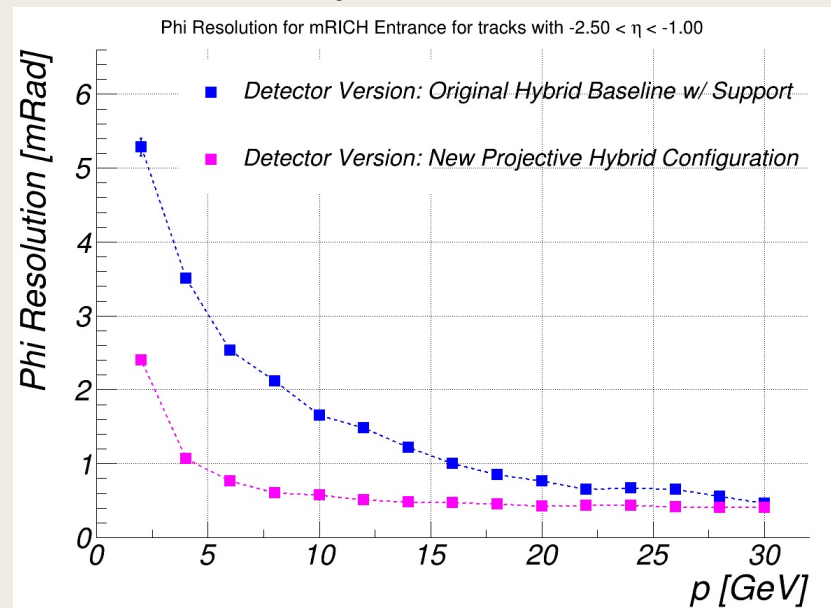

$-3.5 < \eta < -2.5$

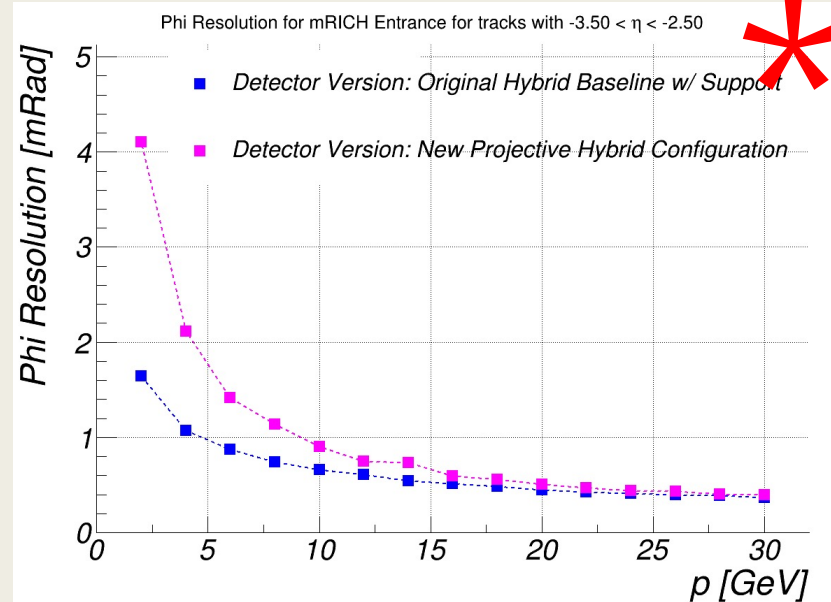

* Rear GEM disk at $z = -190$ plays significant role

DIRC Angular Resolution ($r = 100$ cm)

θ Resolutions

ϕ Resolutions

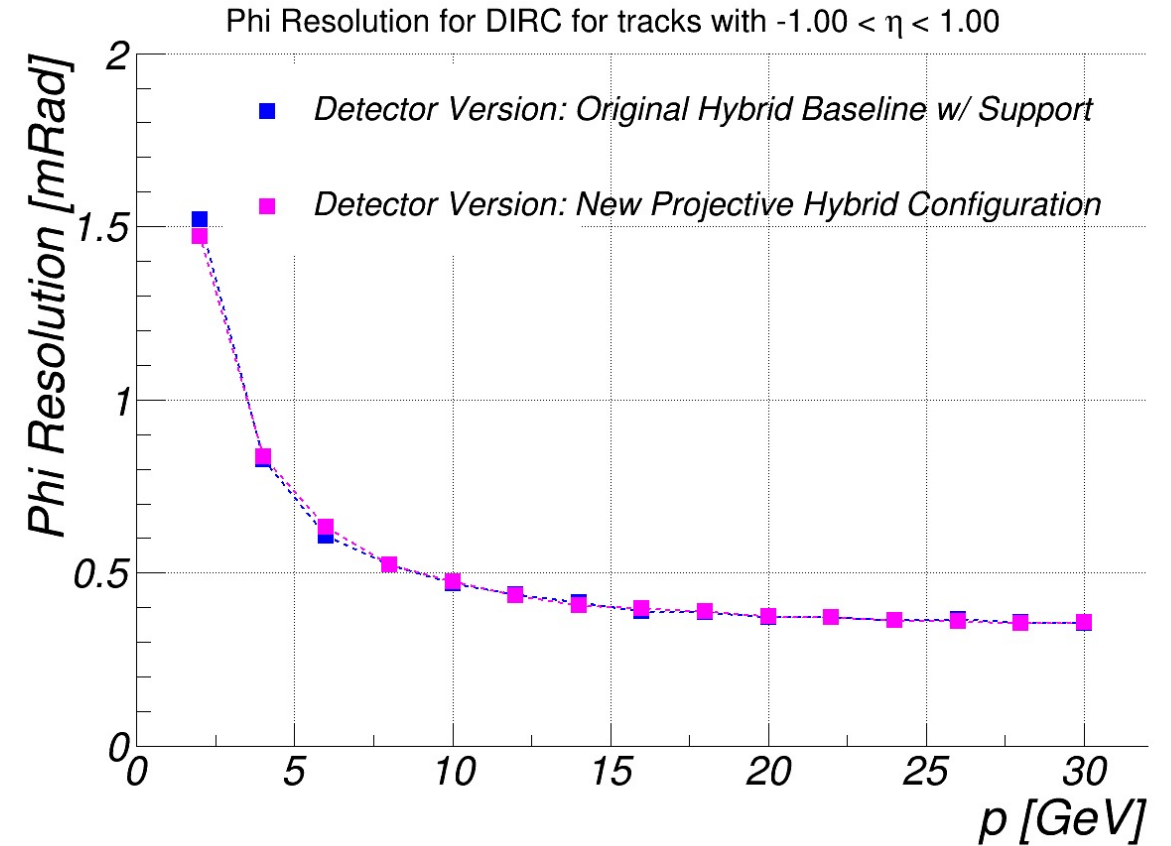
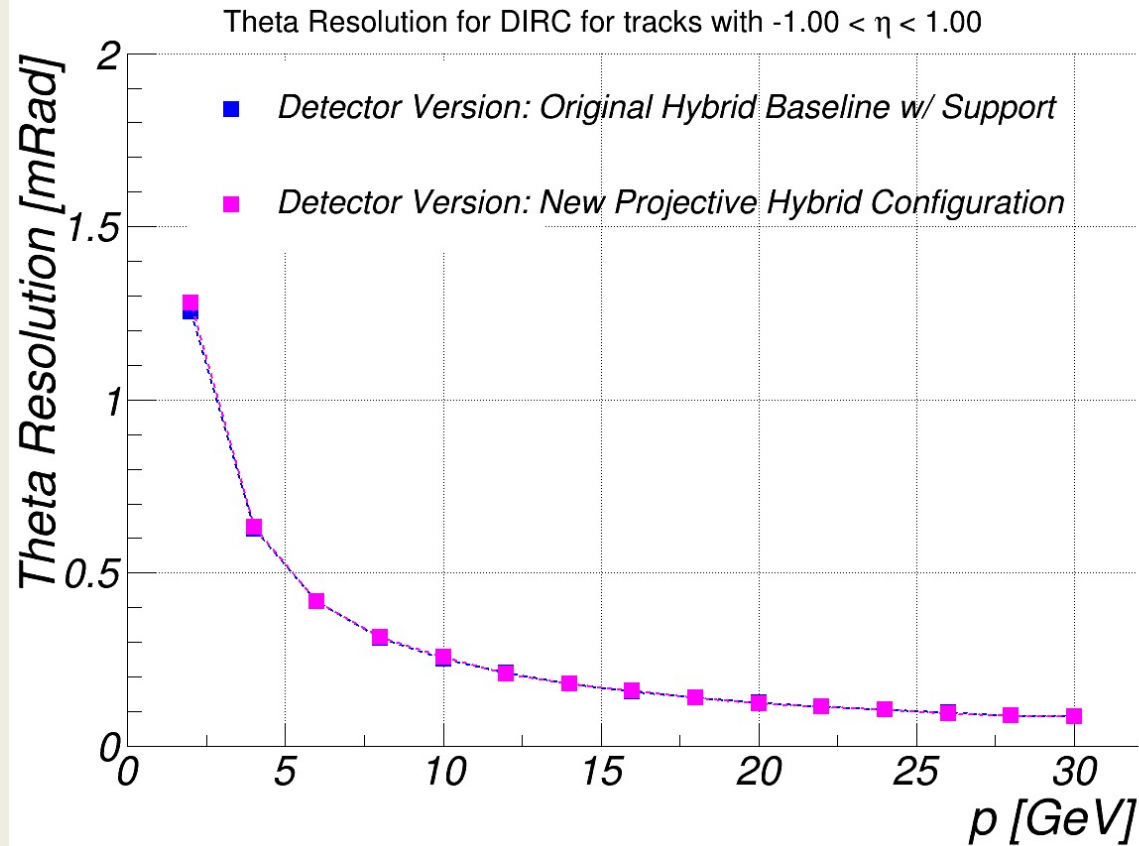

dRICH Polar Angle Resolution

dRICH Entrance Resolutions ($z = +146$ cm)

dRICH Exit Resolutions ($z = +301$ cm)

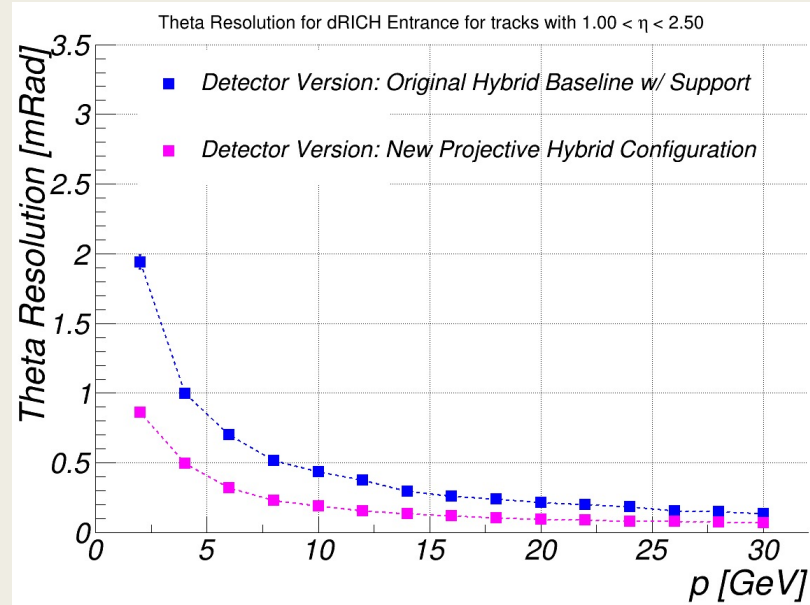

$1.0 < \eta < 2.5$

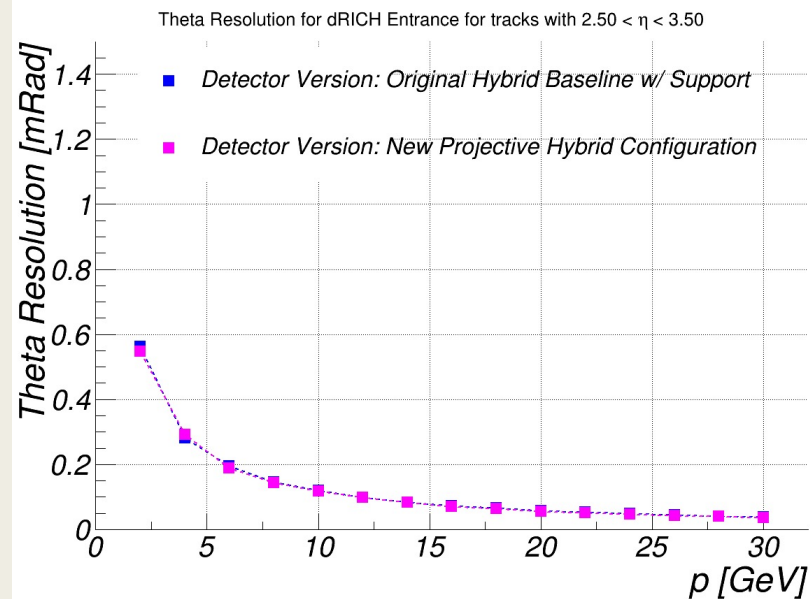
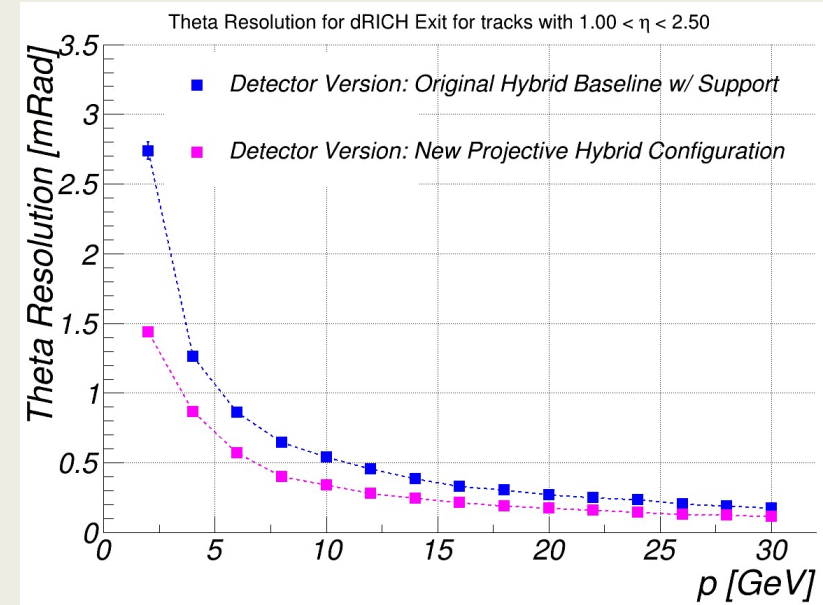

$2.5 < \eta < 3.5$

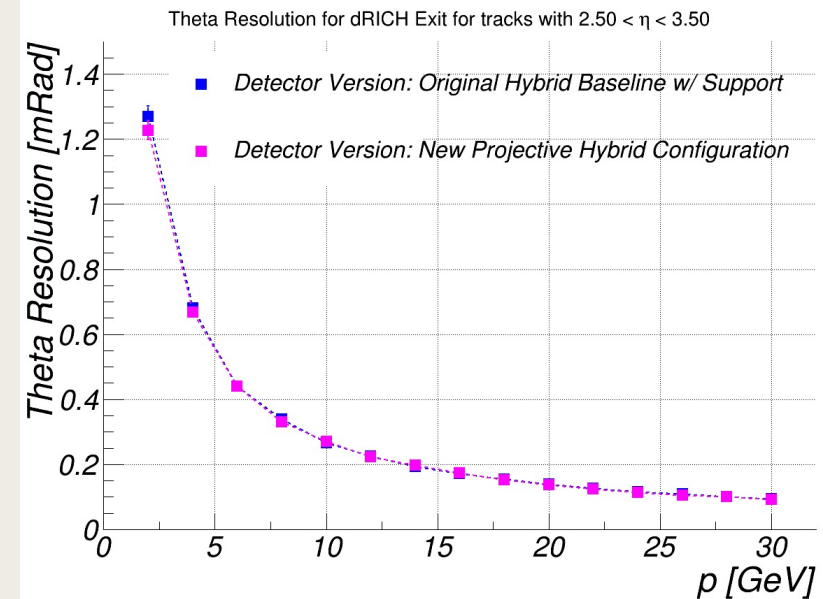

dRICH Azimuthal Angle Resolution

dRICH Entrance Resolutions ($z = +146$ cm)

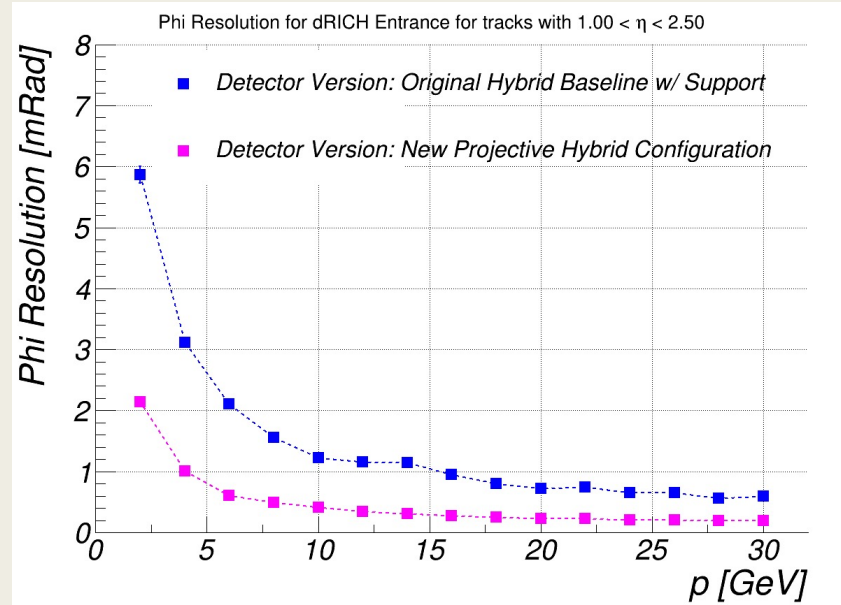

$1.0 < \eta < 2.5$

dRICH Exit Resolutions ($z = +301$ cm)

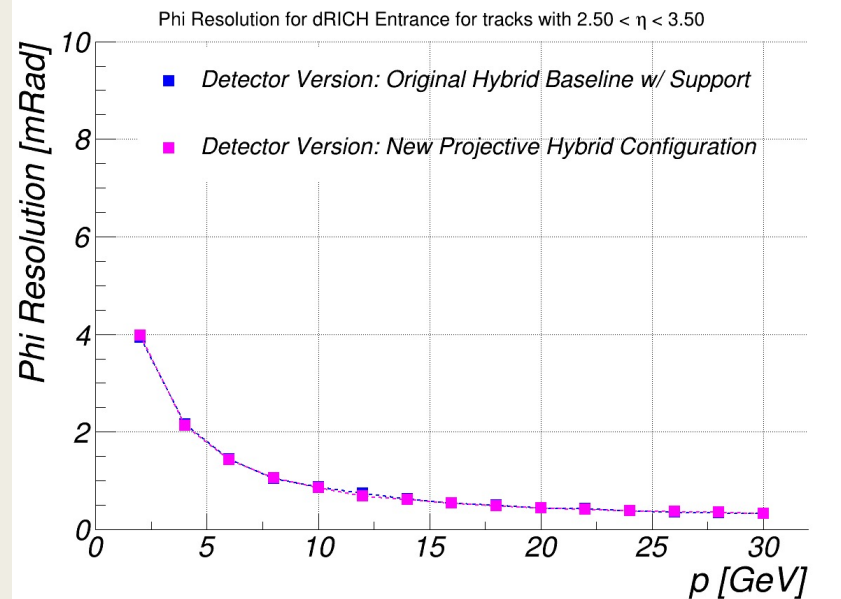
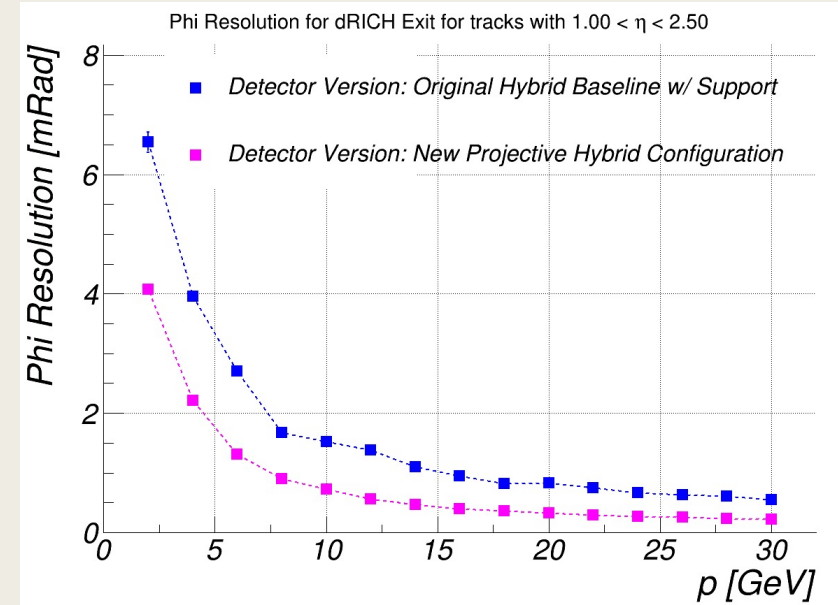

$2.5 < \eta < 3.5$

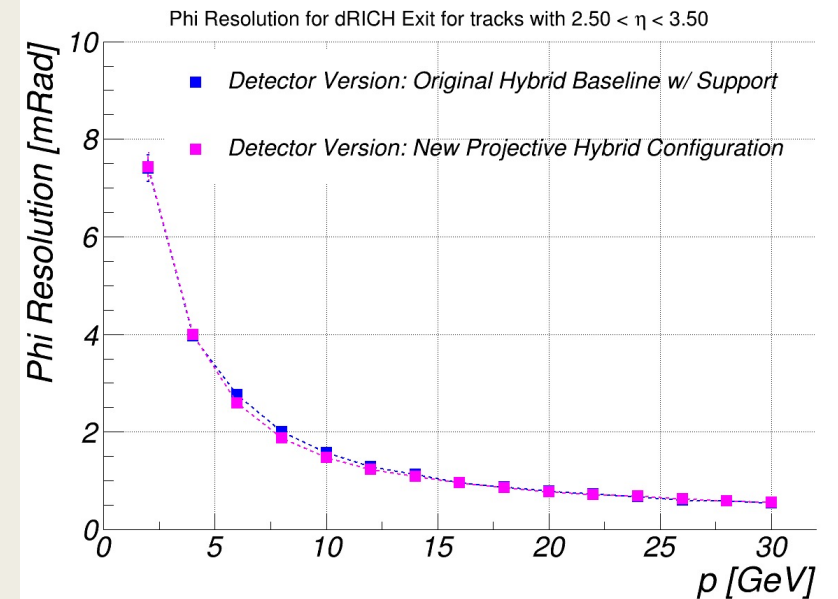

Stacked Material Scan

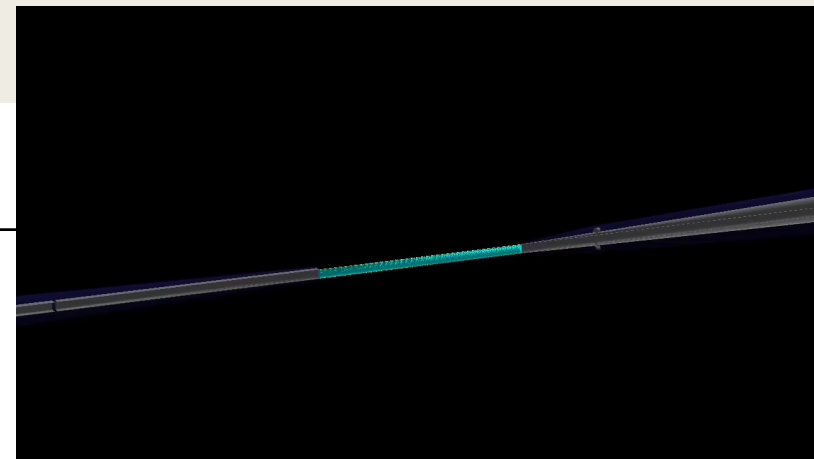
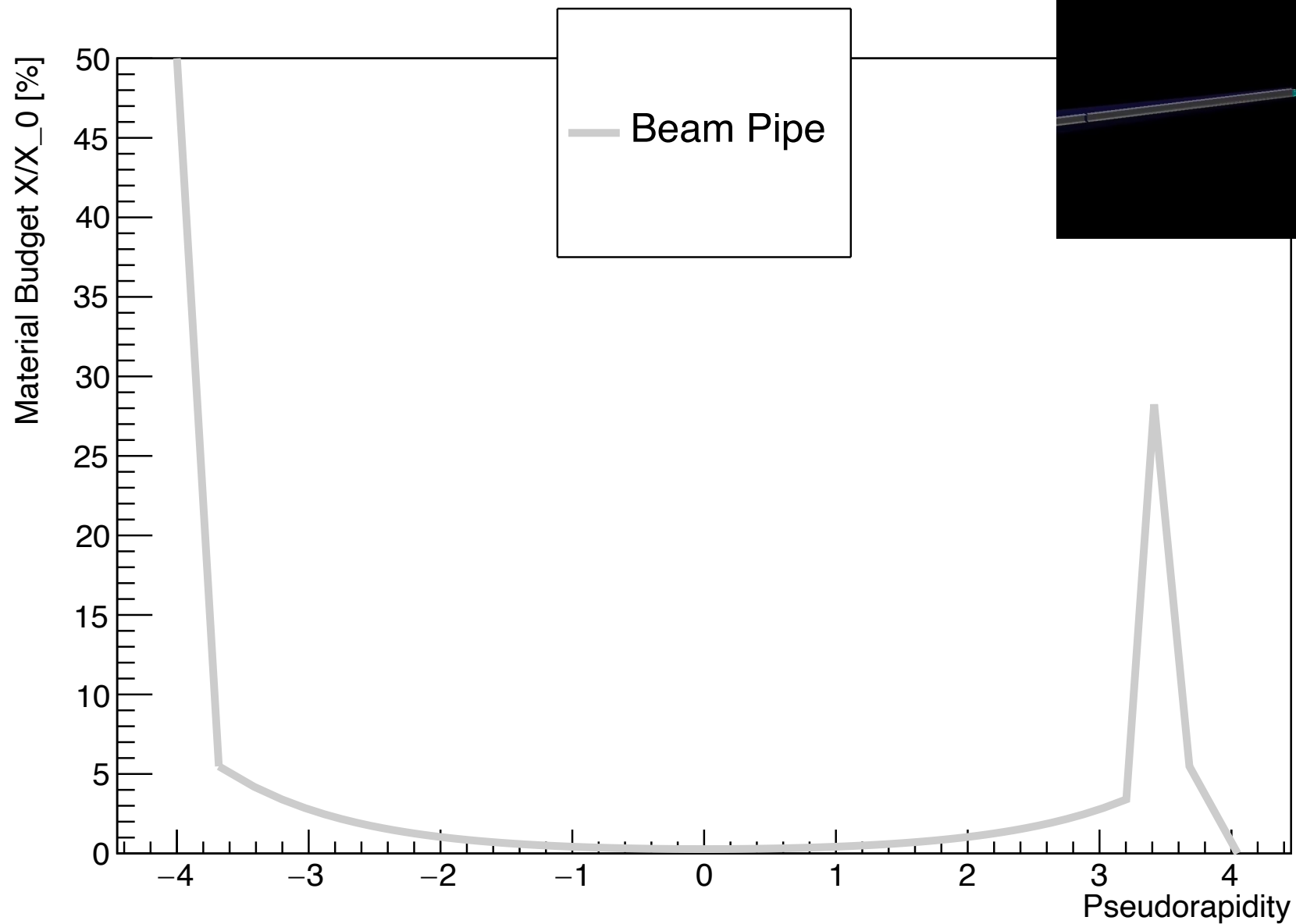

Stacked Material Scan

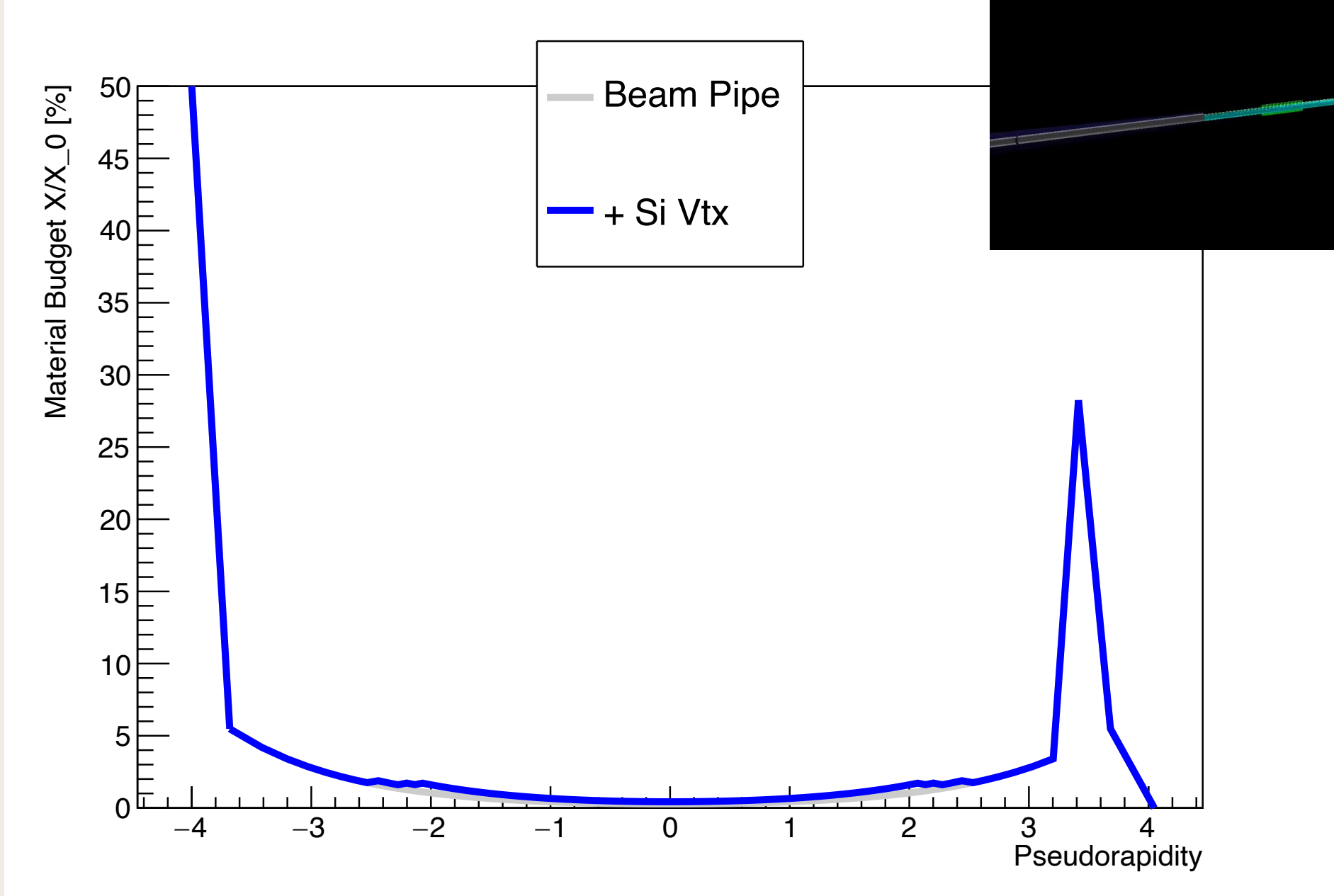

Stacked Material Scan

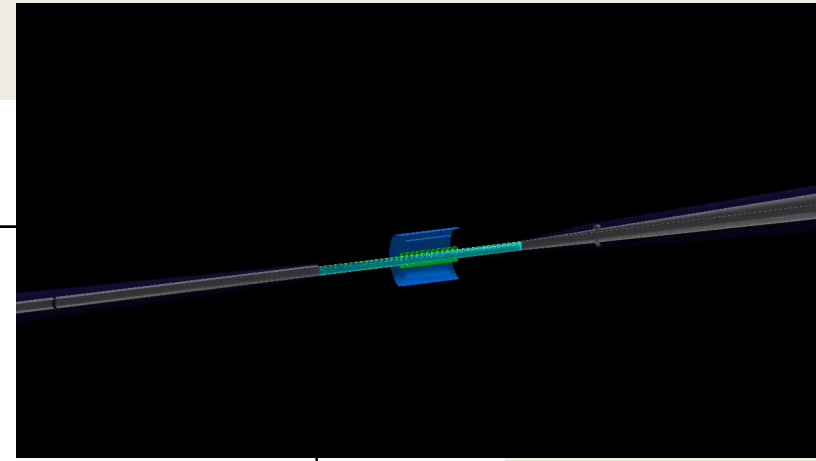
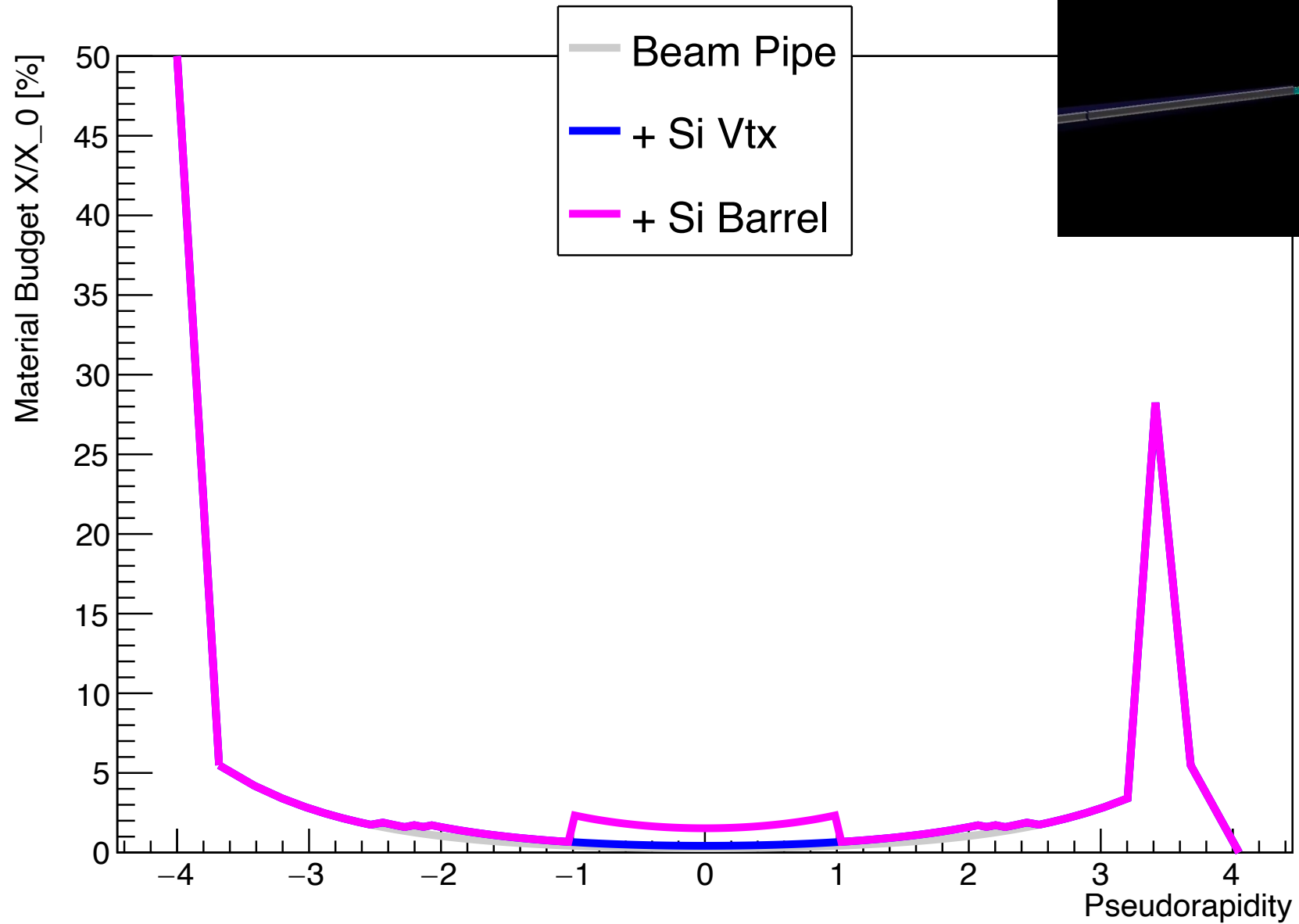

Stacked Material Scan

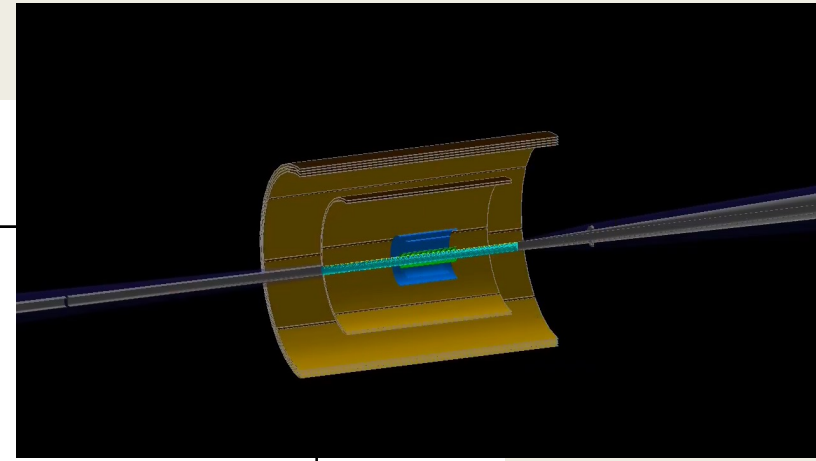
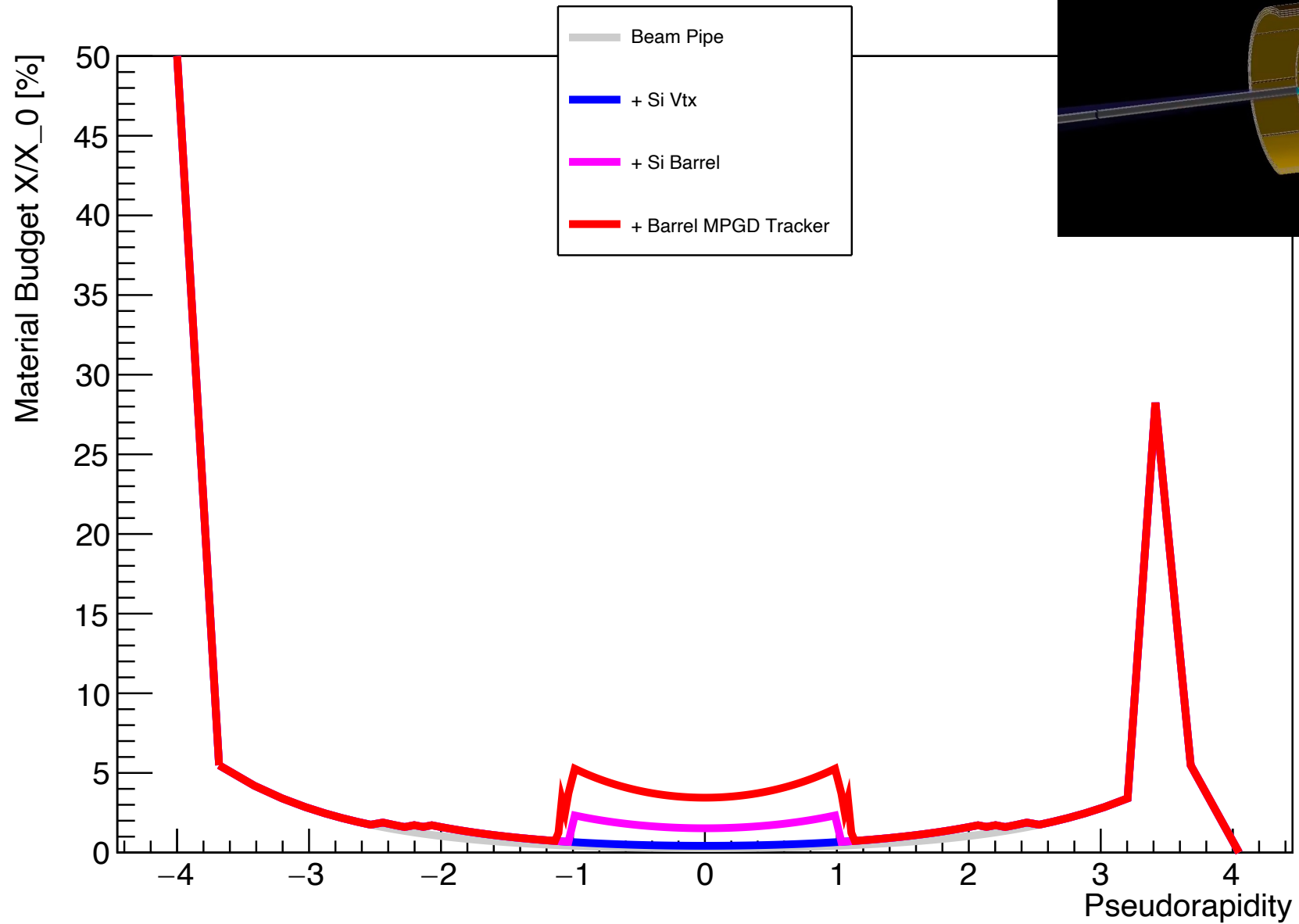

Stacked Material Scan

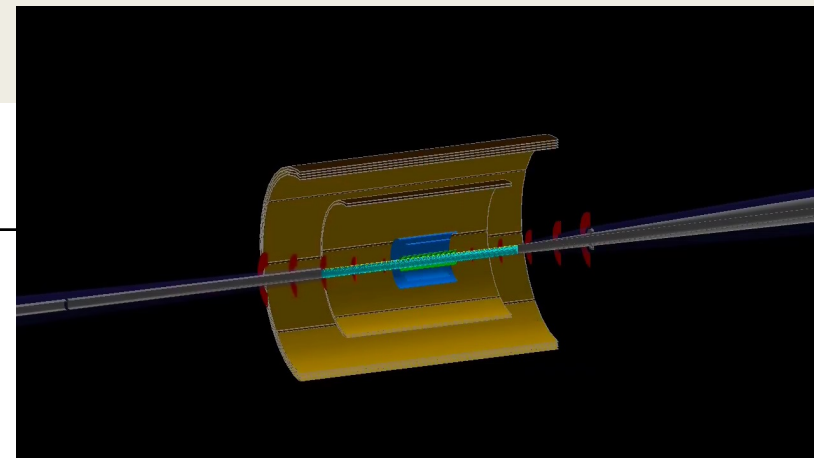
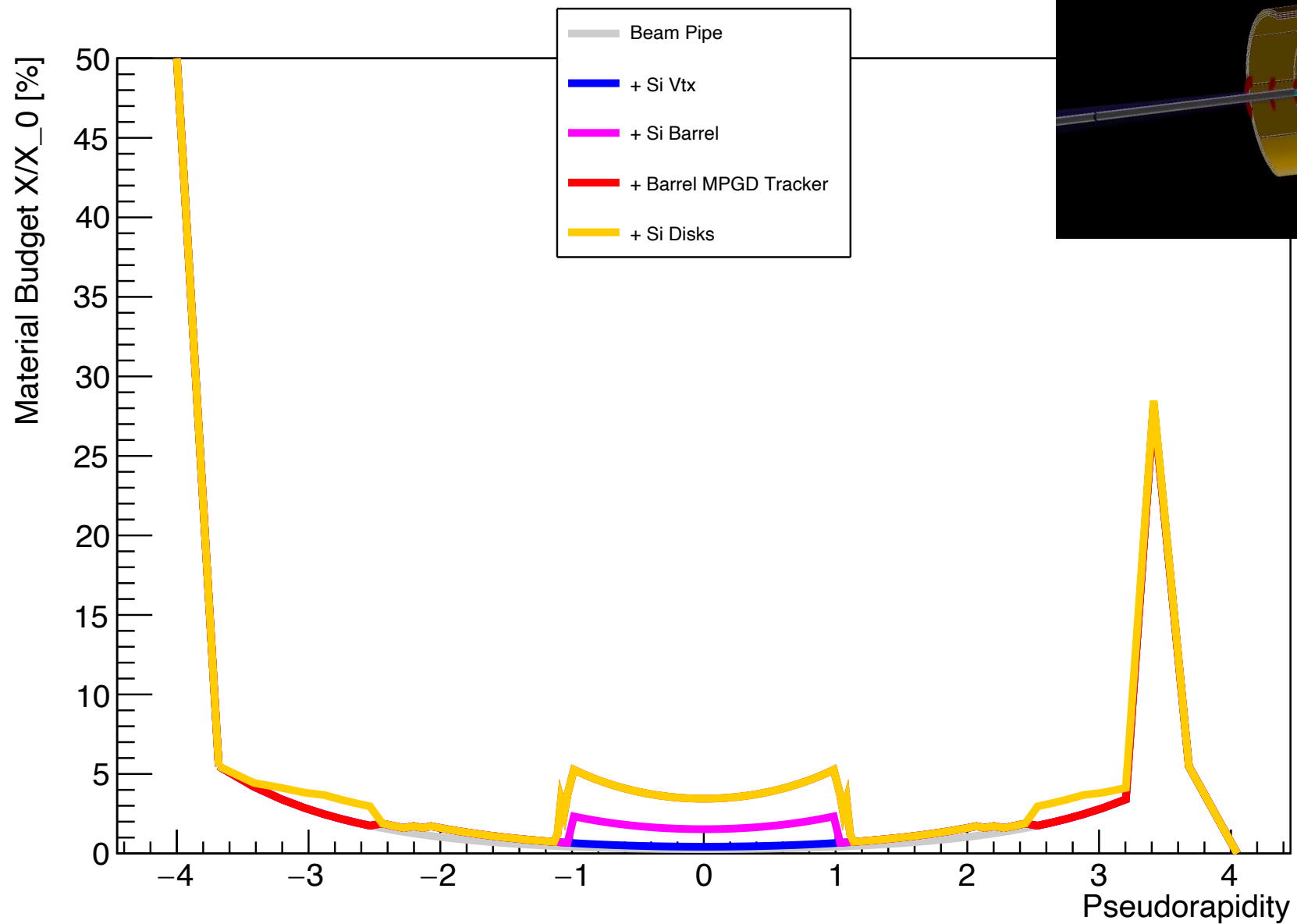

Stacked Material Scan

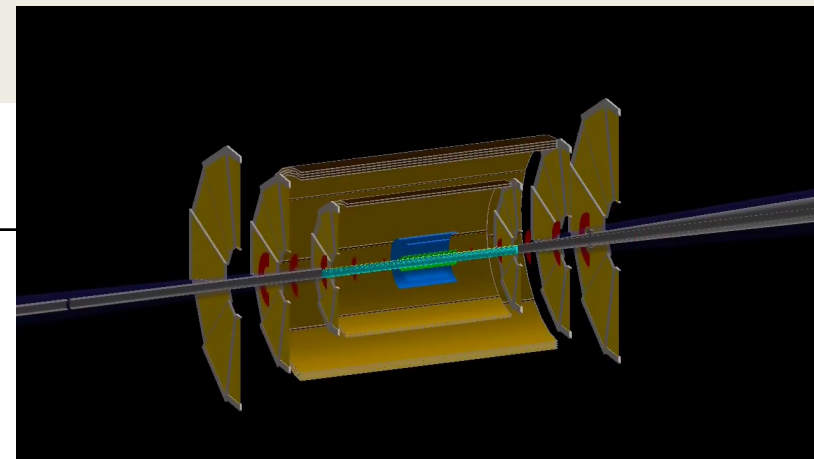
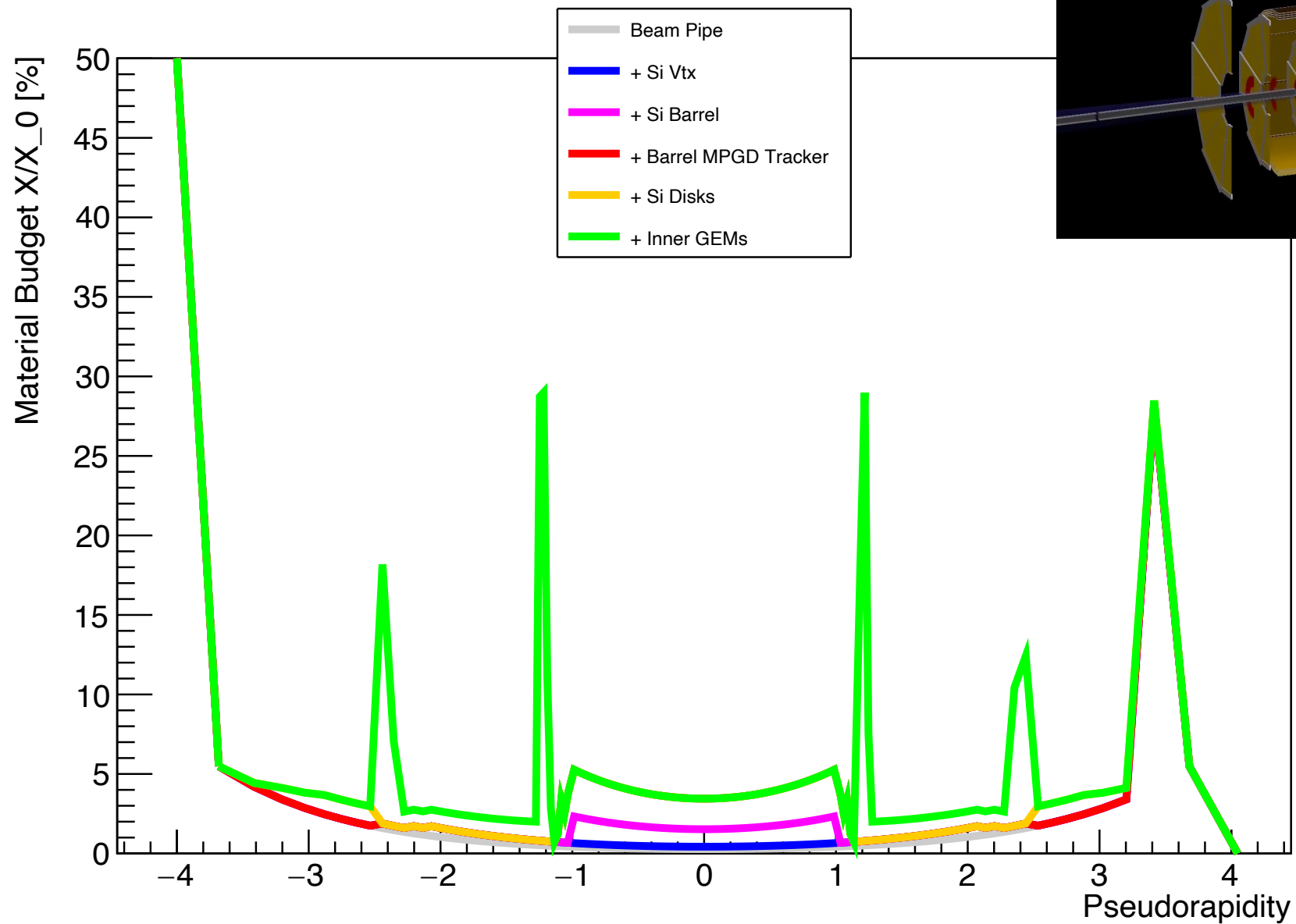

Stacked Material Scan

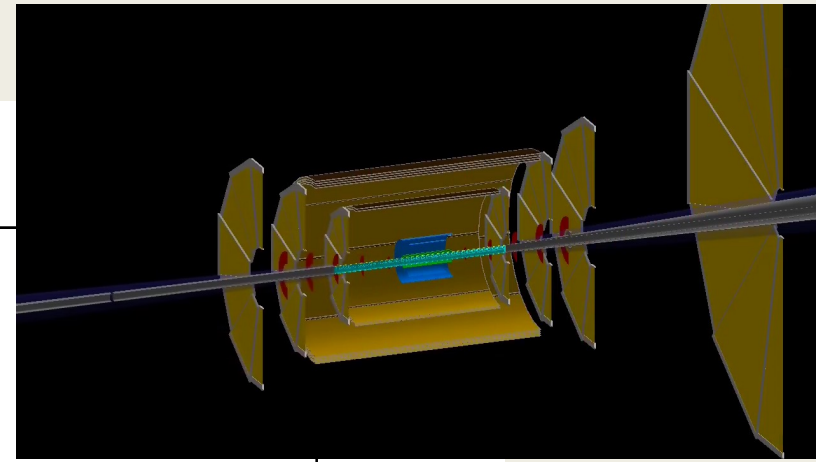
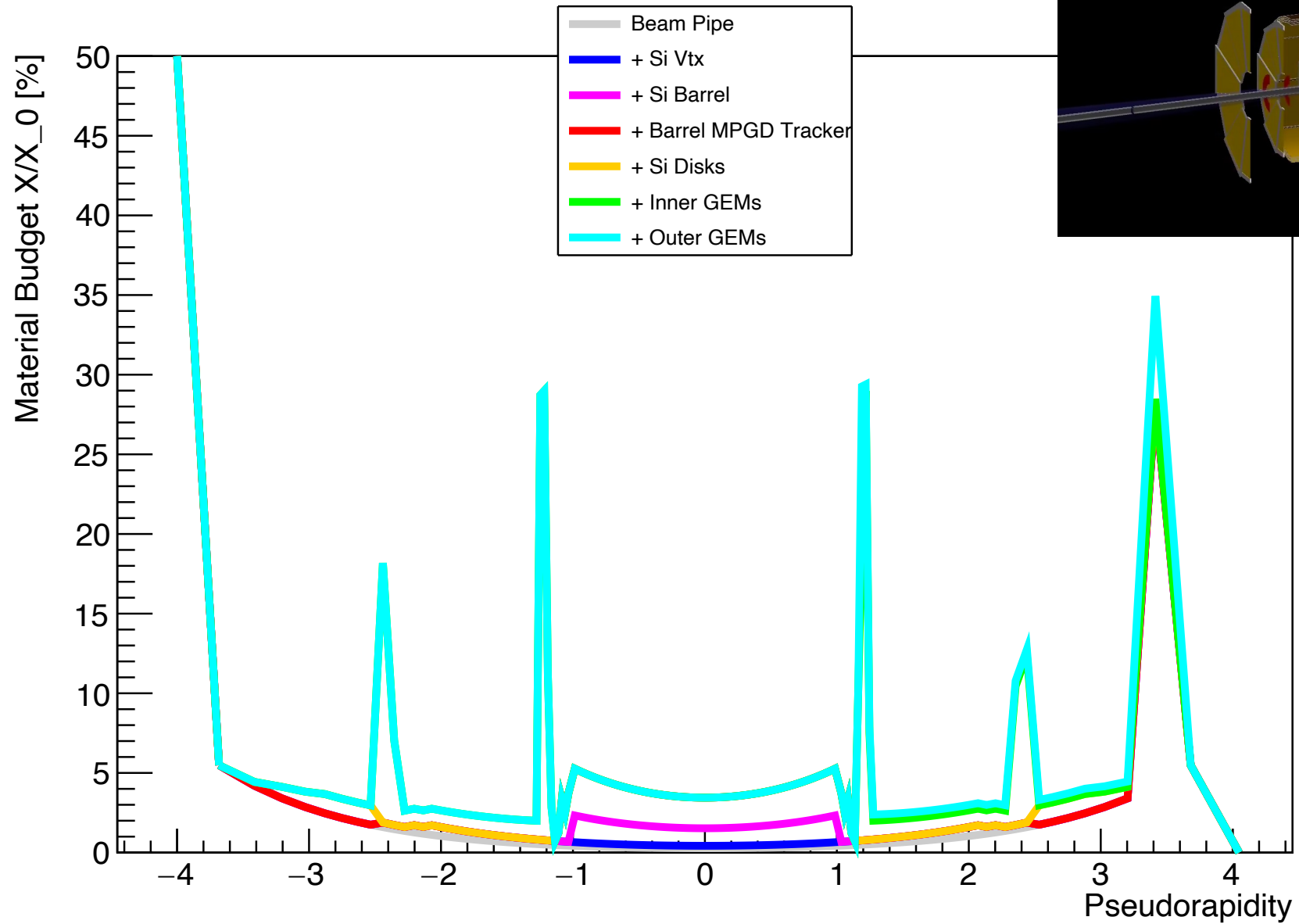

Stacked Material Scan

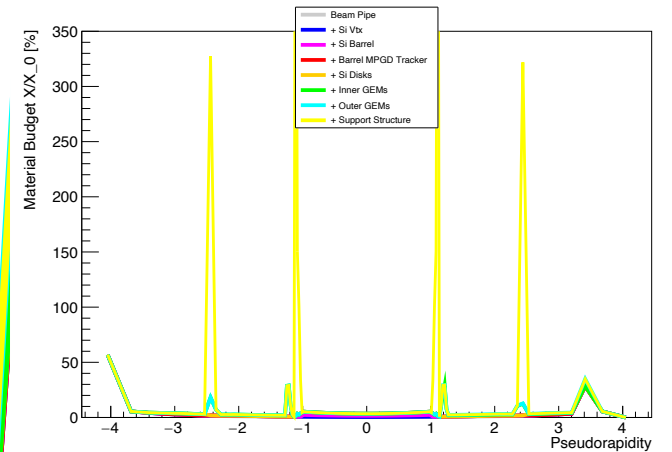
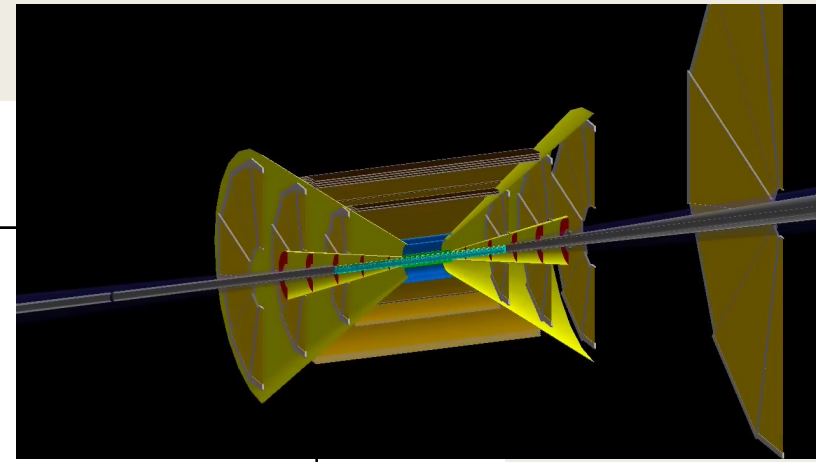
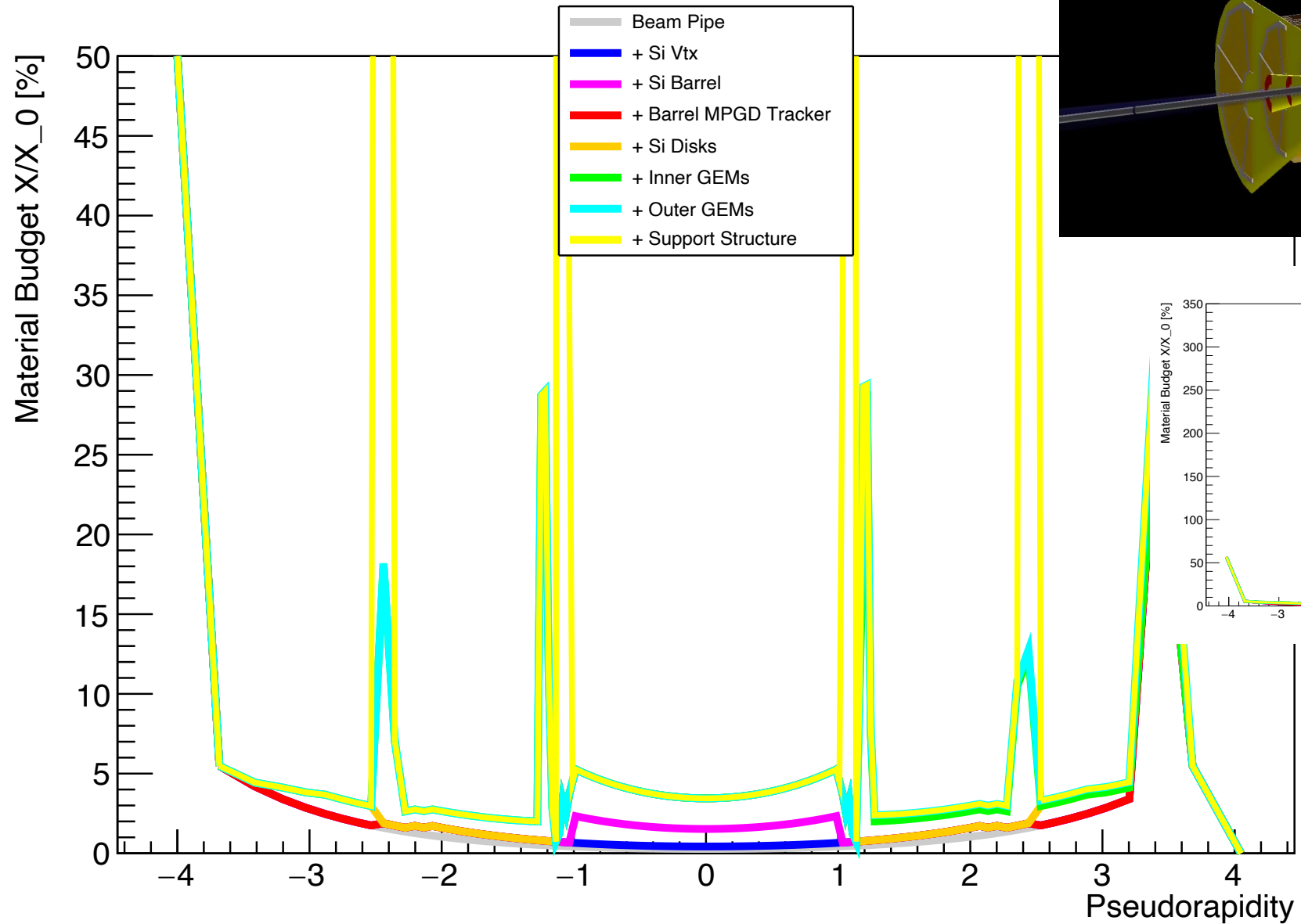

Stacked Material Scan

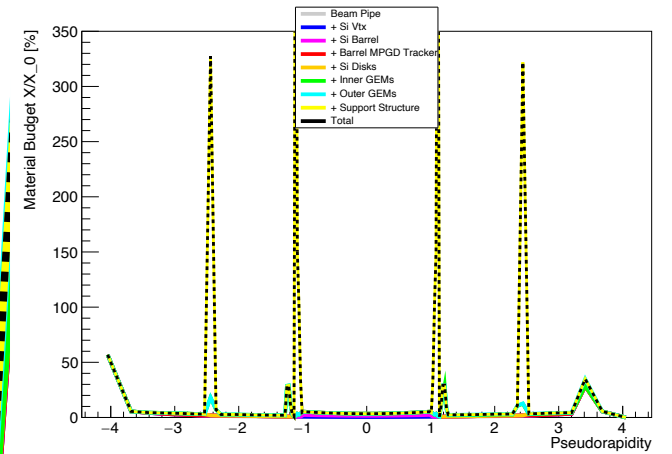
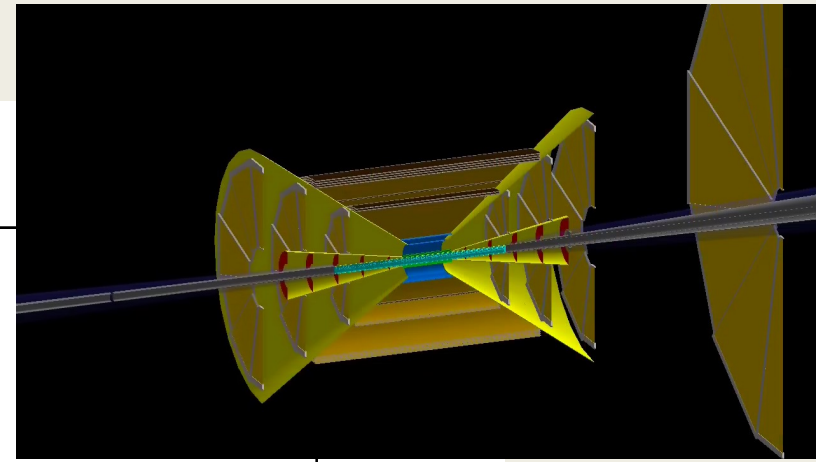
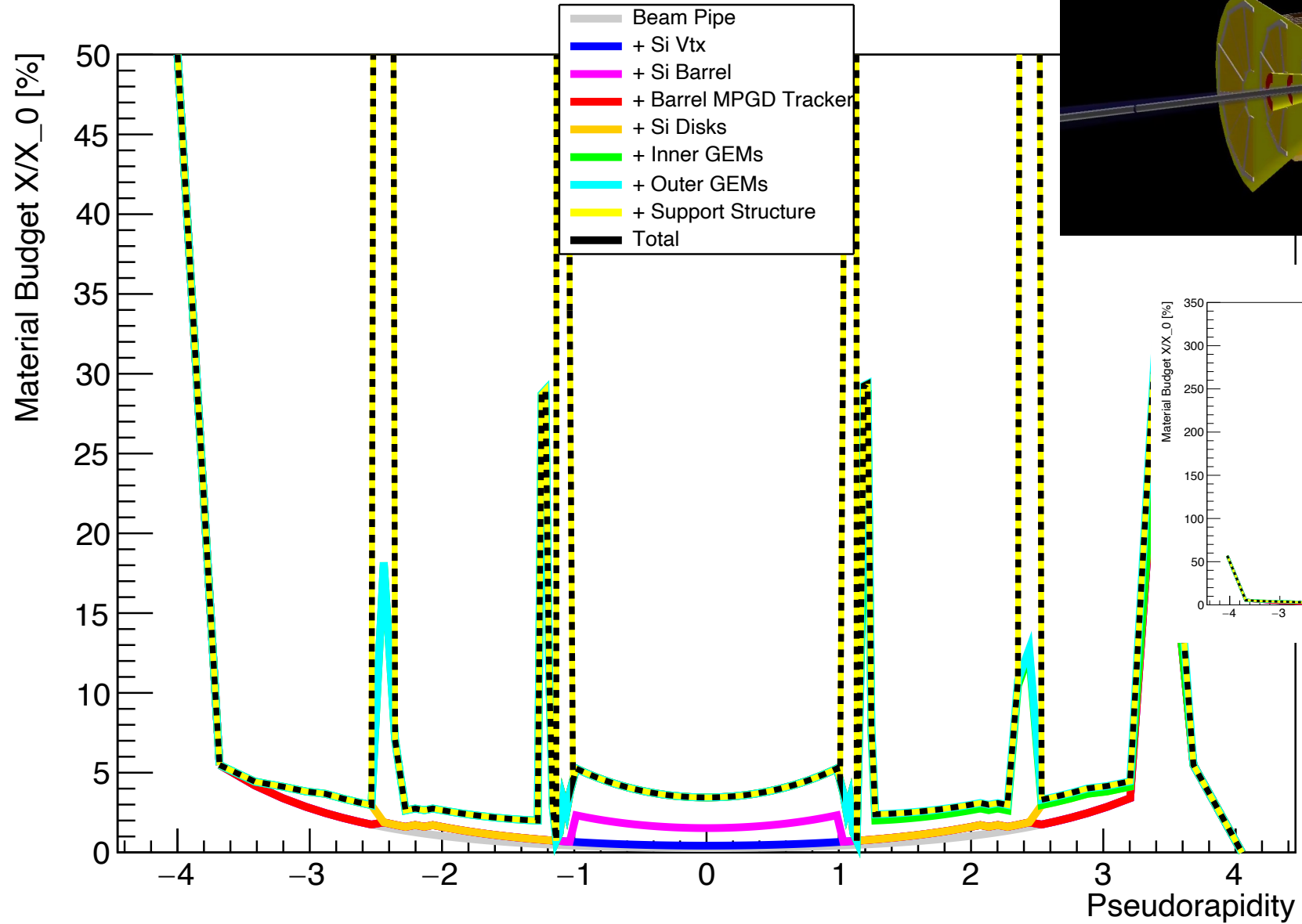

Material Scan Comparison

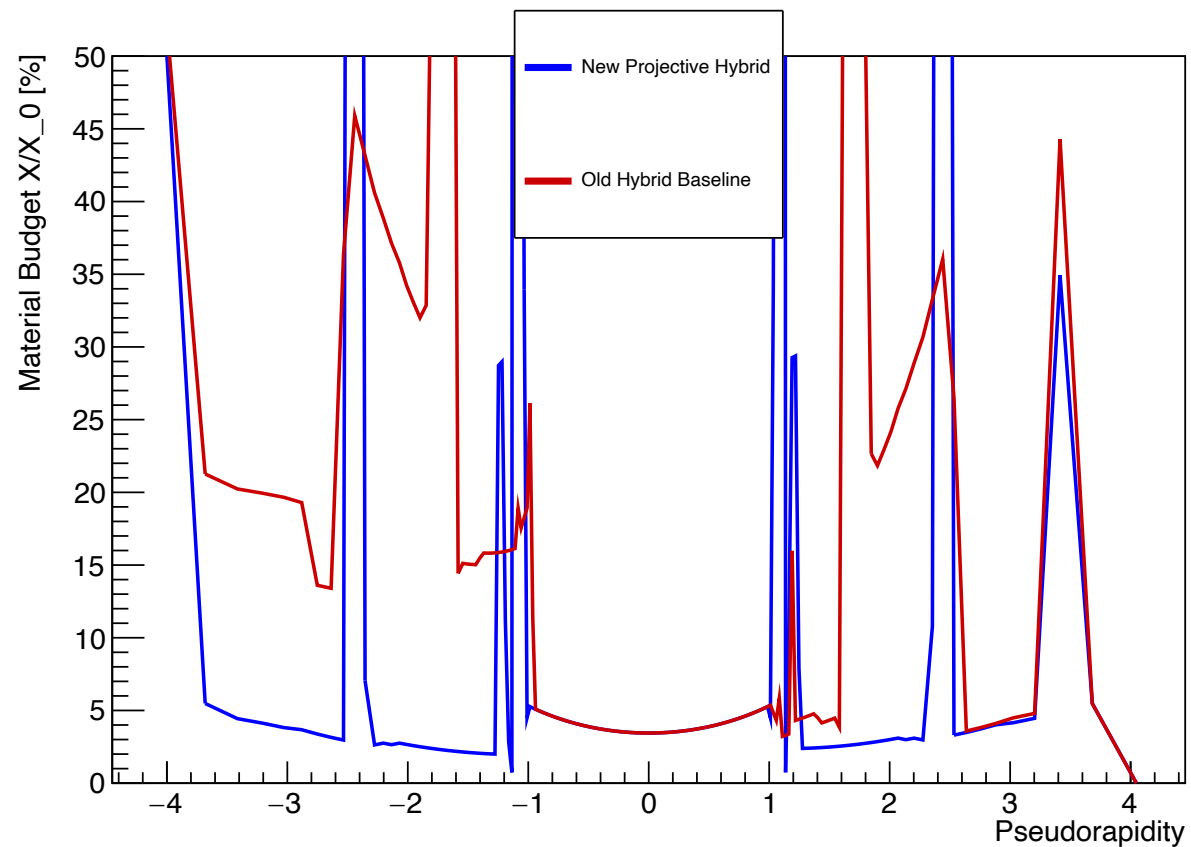
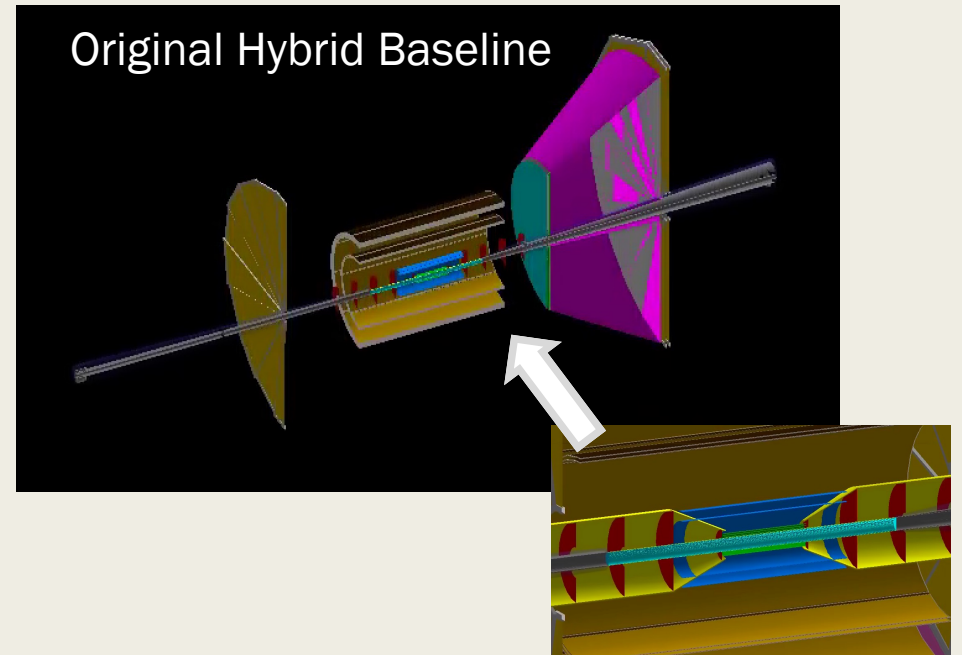
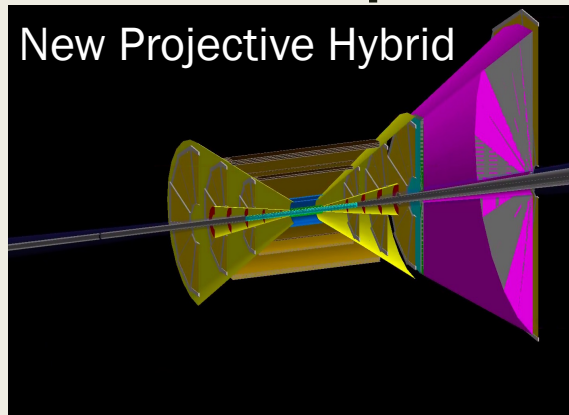

Full Scale

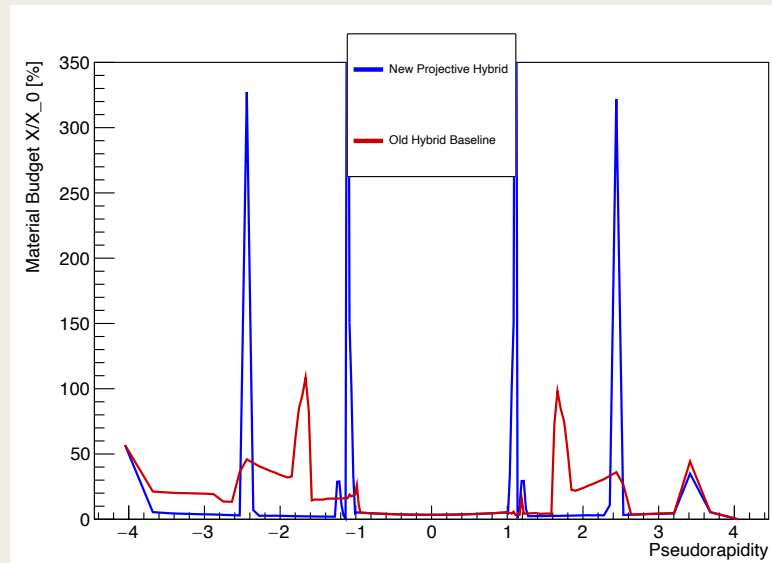

Conclusion

- New projective configuration for the hybrid detector outperforms the original hybrid baseline configuration in nearly every metric.
- Less material in regions $1.3 < |\eta| < 2.3$ and $|\eta| > 2.6$
- Propose using this new configuration as the hybrid baseline going forward
- To Do:
 - *Simulate low transverse momentum pions for vertex pointing resolutions*
 - *Optimization of the configuration*

BACKUP SLIDES

Angular Resolution Locations

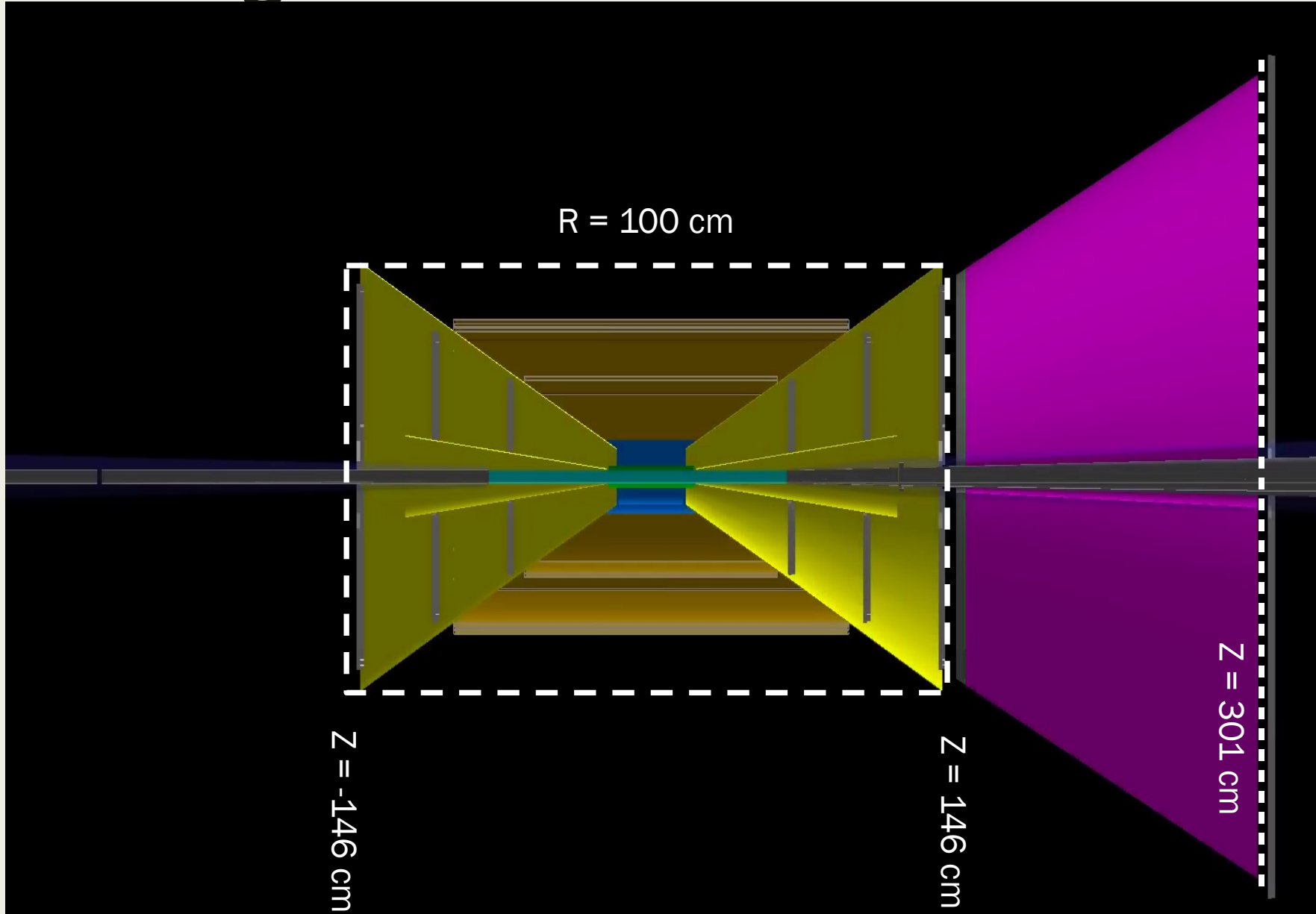

Central Region Comparisons

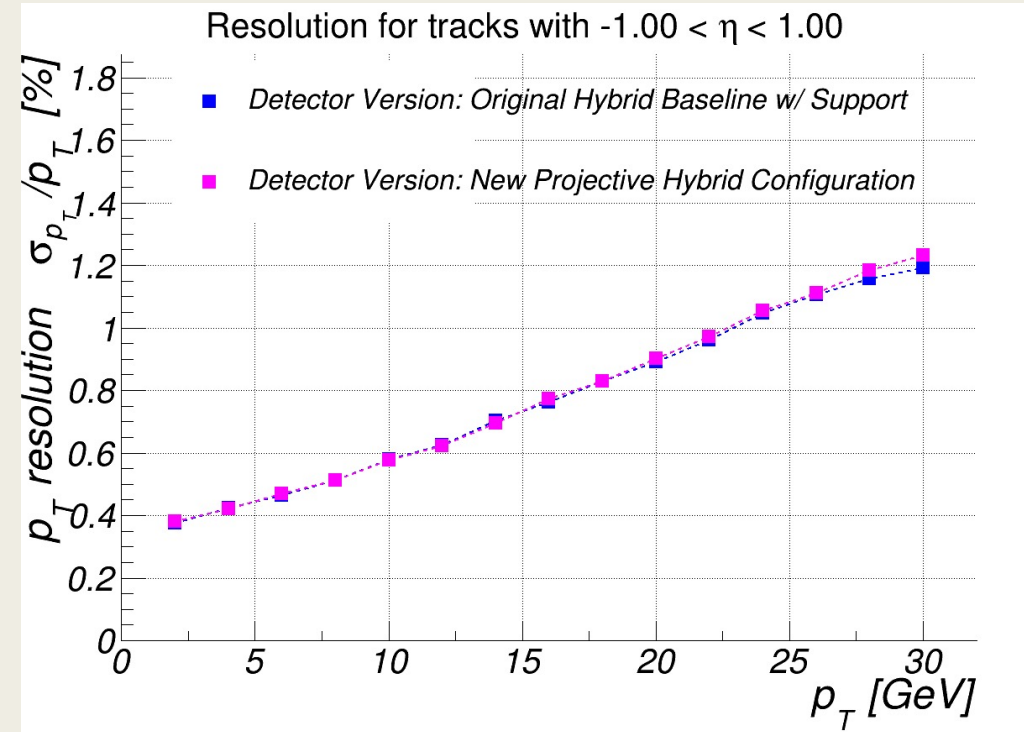
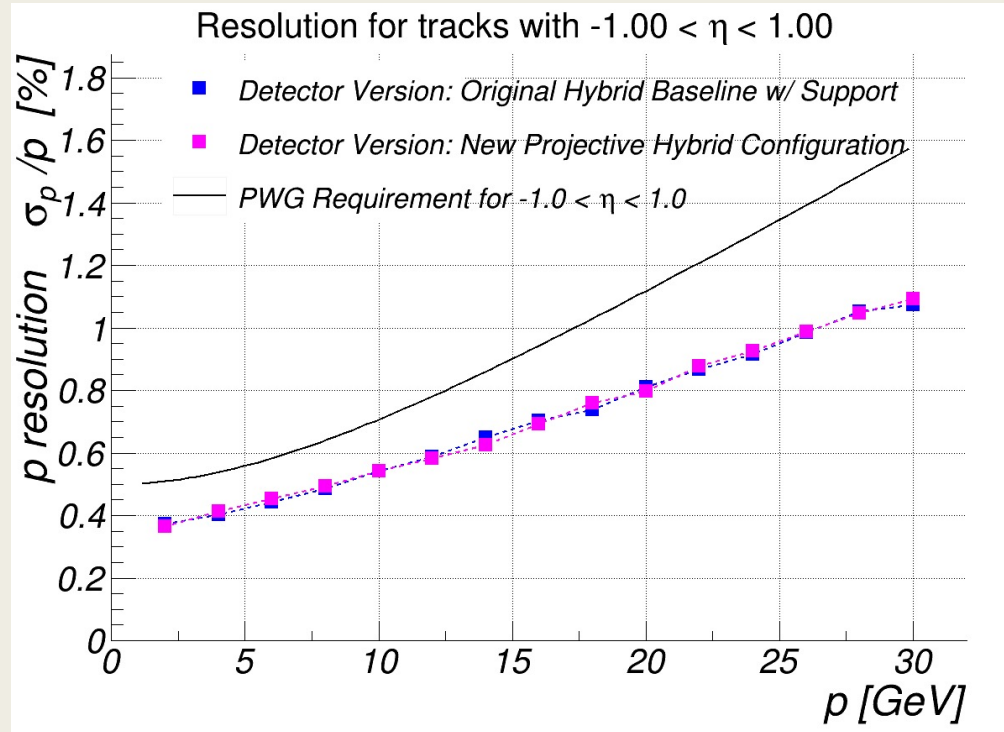

Rear GEM in Baseline Effect on Resolution – P Res.

With rear GEM at $z = -190$ cm in Baseline

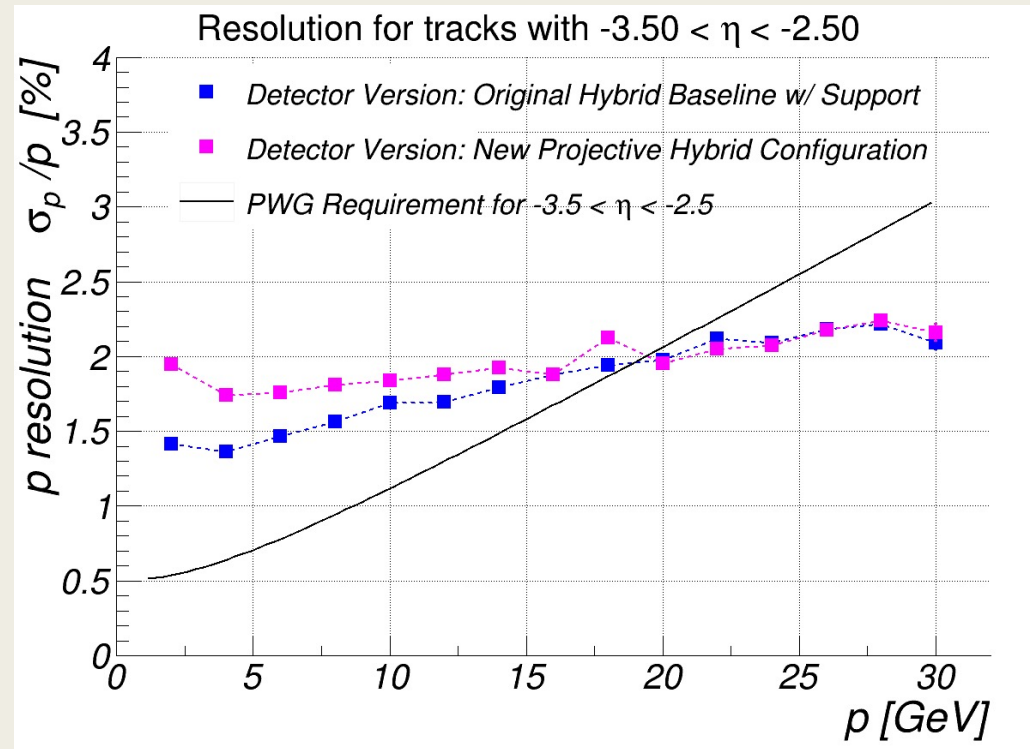

Without rear GEM at $z = -190$ cm in Baseline

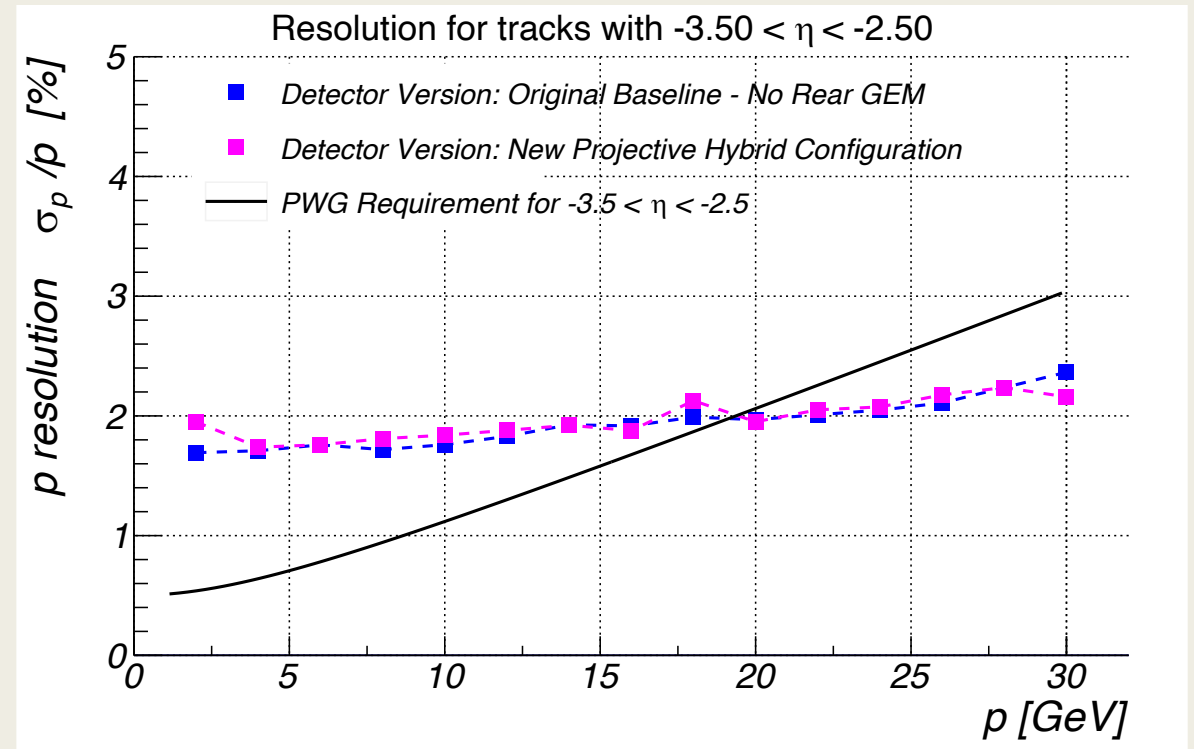

Rear GEM in Baseline Effect on Resolution – Phi Res.

With rear GEM at $z = -190$ cm in Baseline

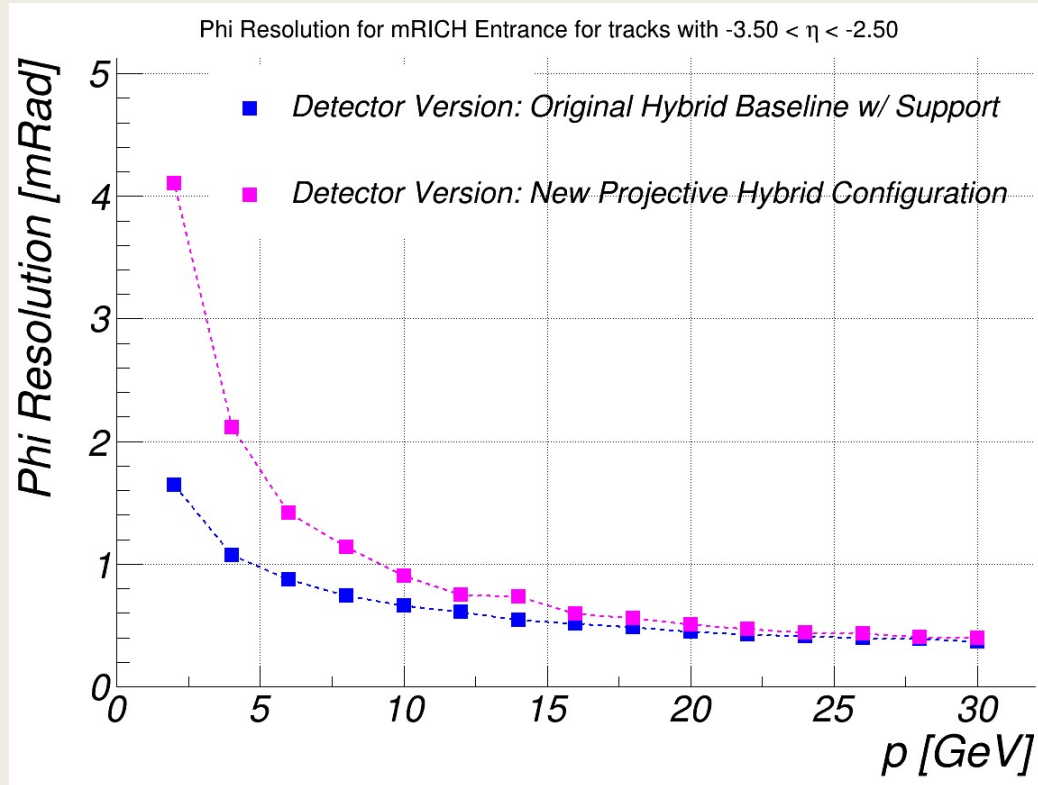

Without rear GEM at $z = -190$ cm in Baseline

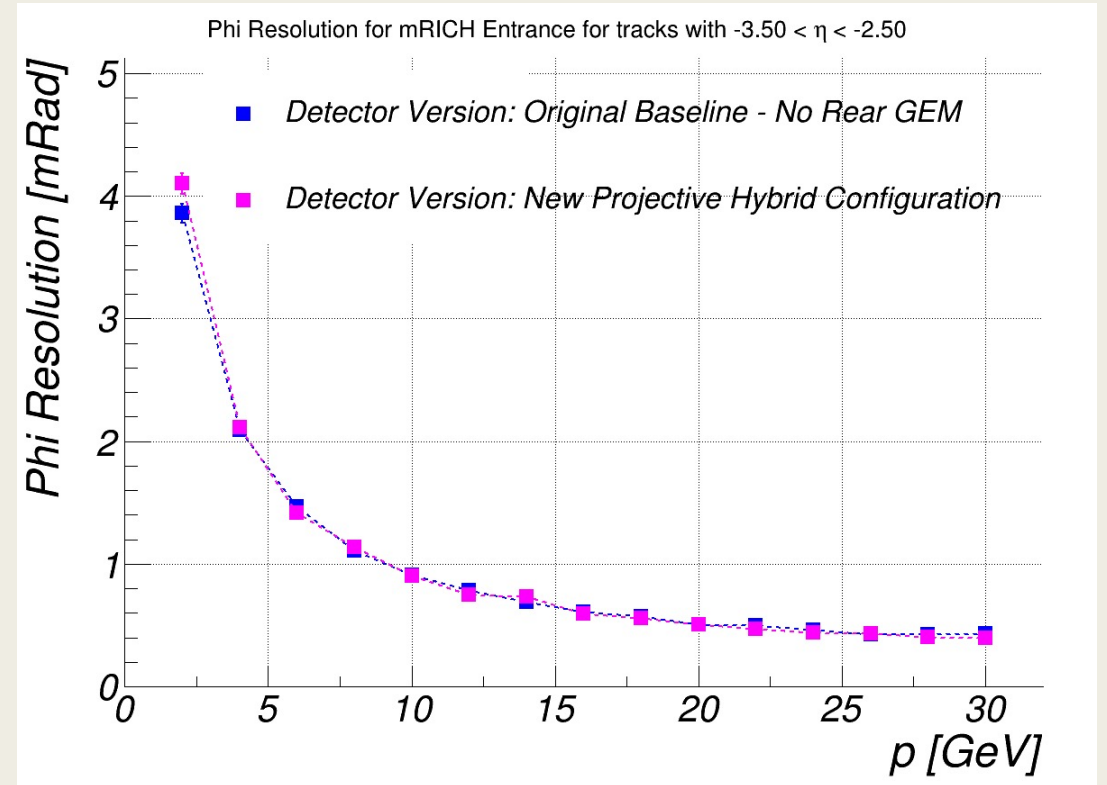

Rear GEM in Baseline Effect on Resolution – Pt Res.

With rear GEM at $z = -190$ cm in Baseline

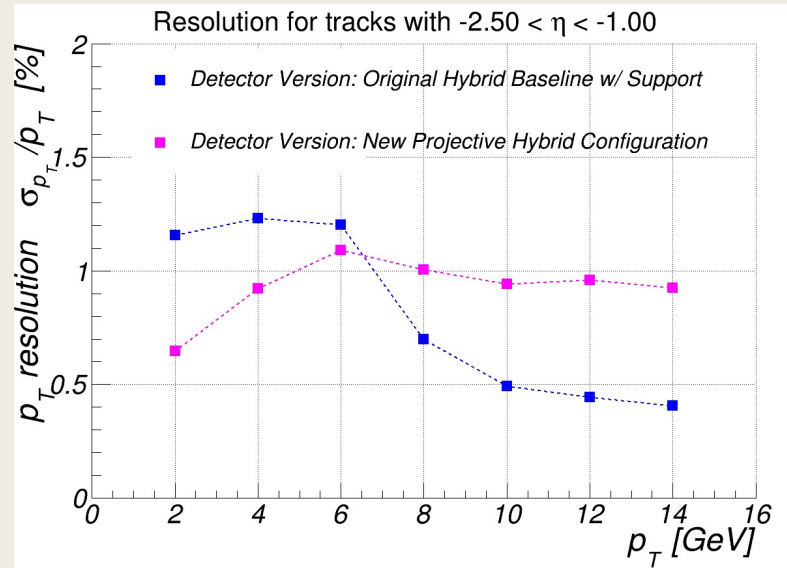

Without rear GEM at $z = -190$ cm in Baseline

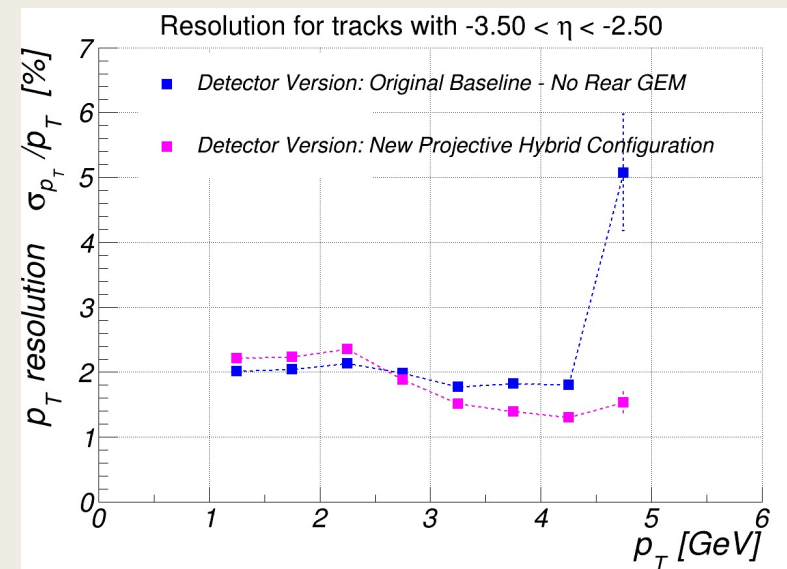
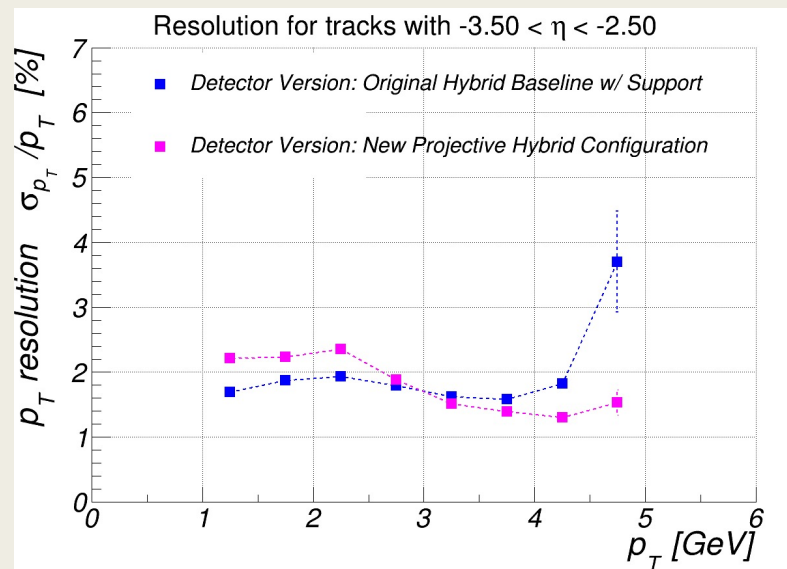
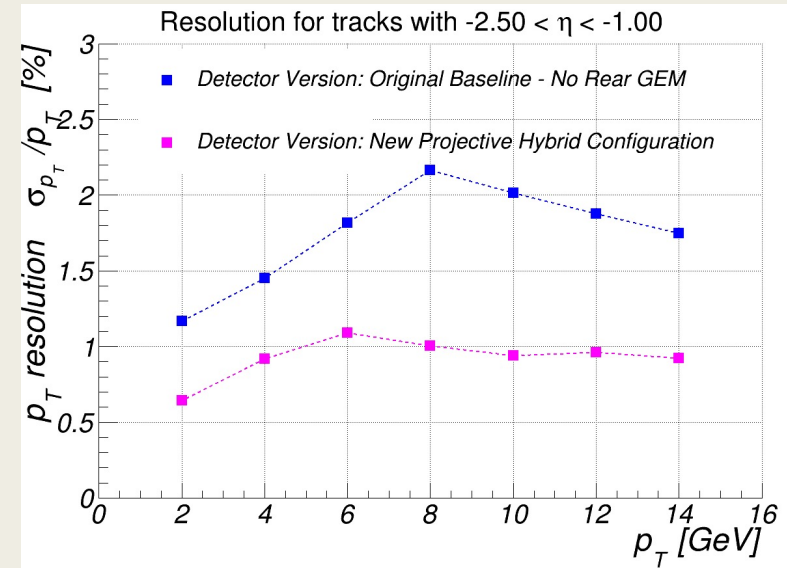

Material Scan

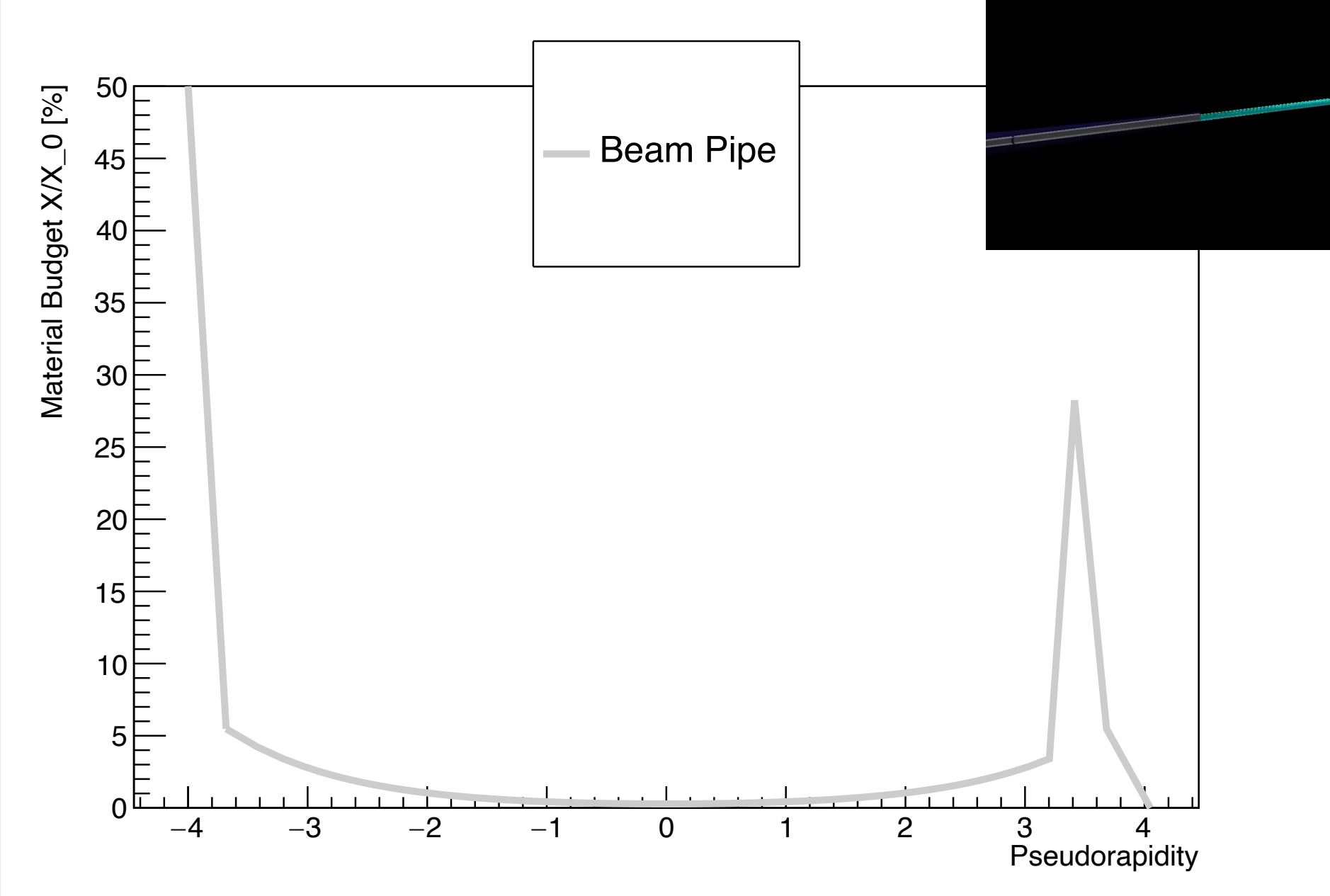

Material Scan

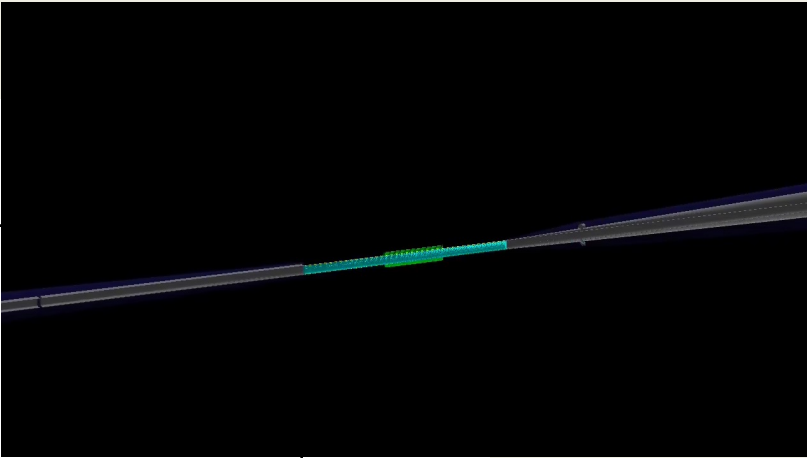
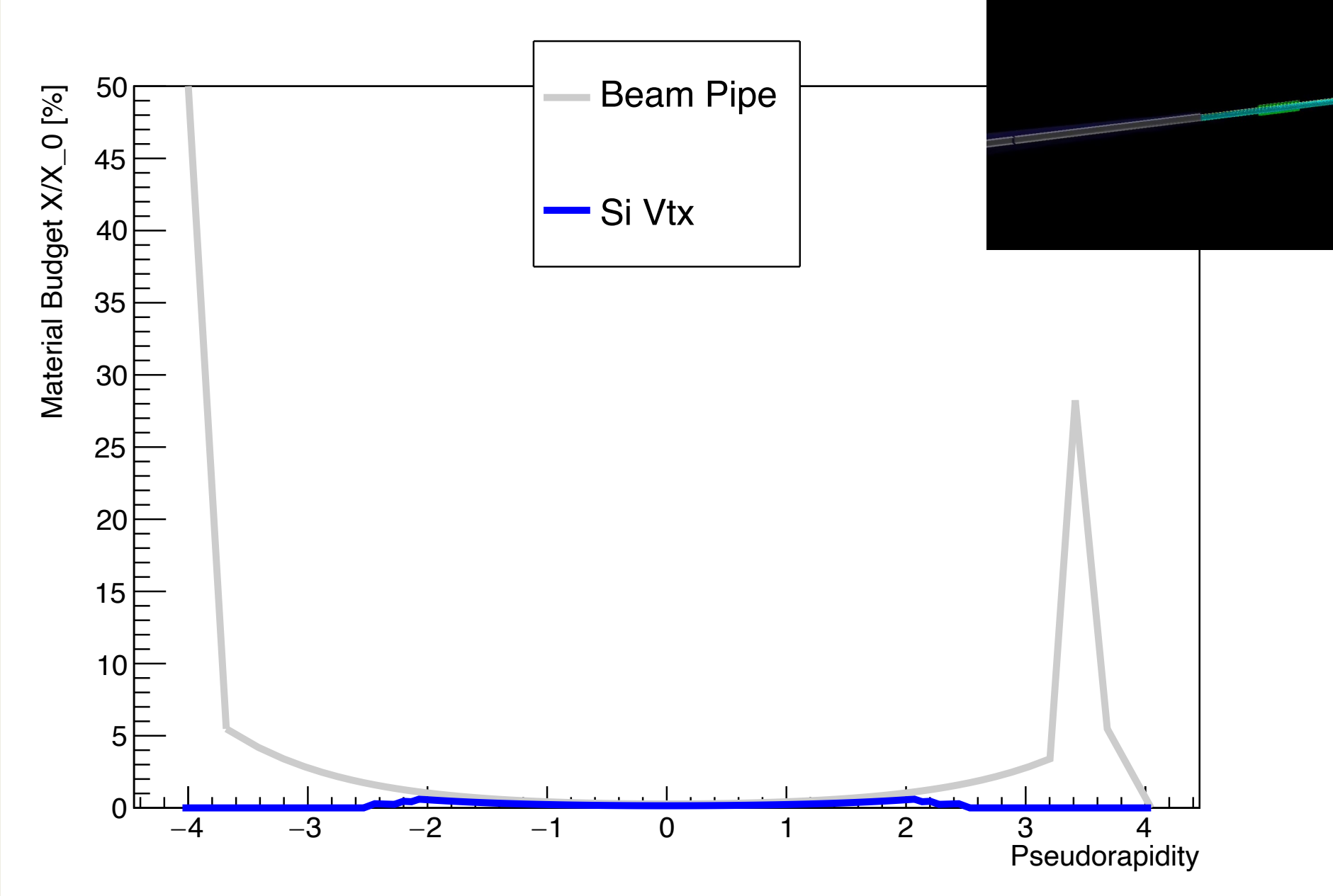

Material Scan

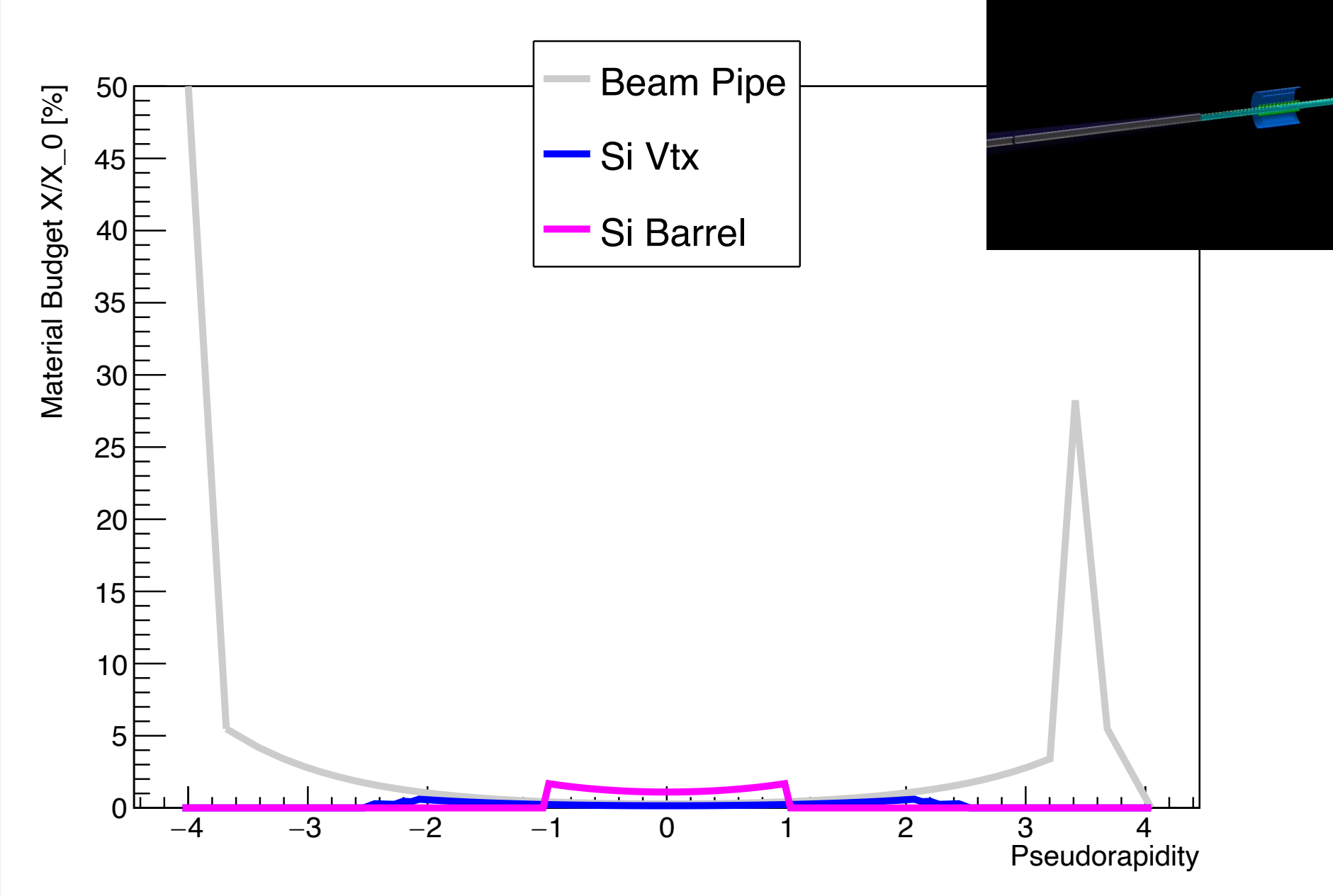

Material Scan

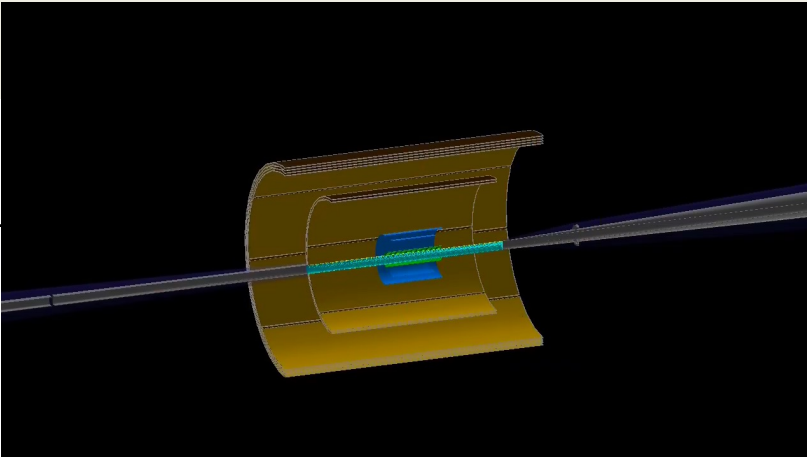
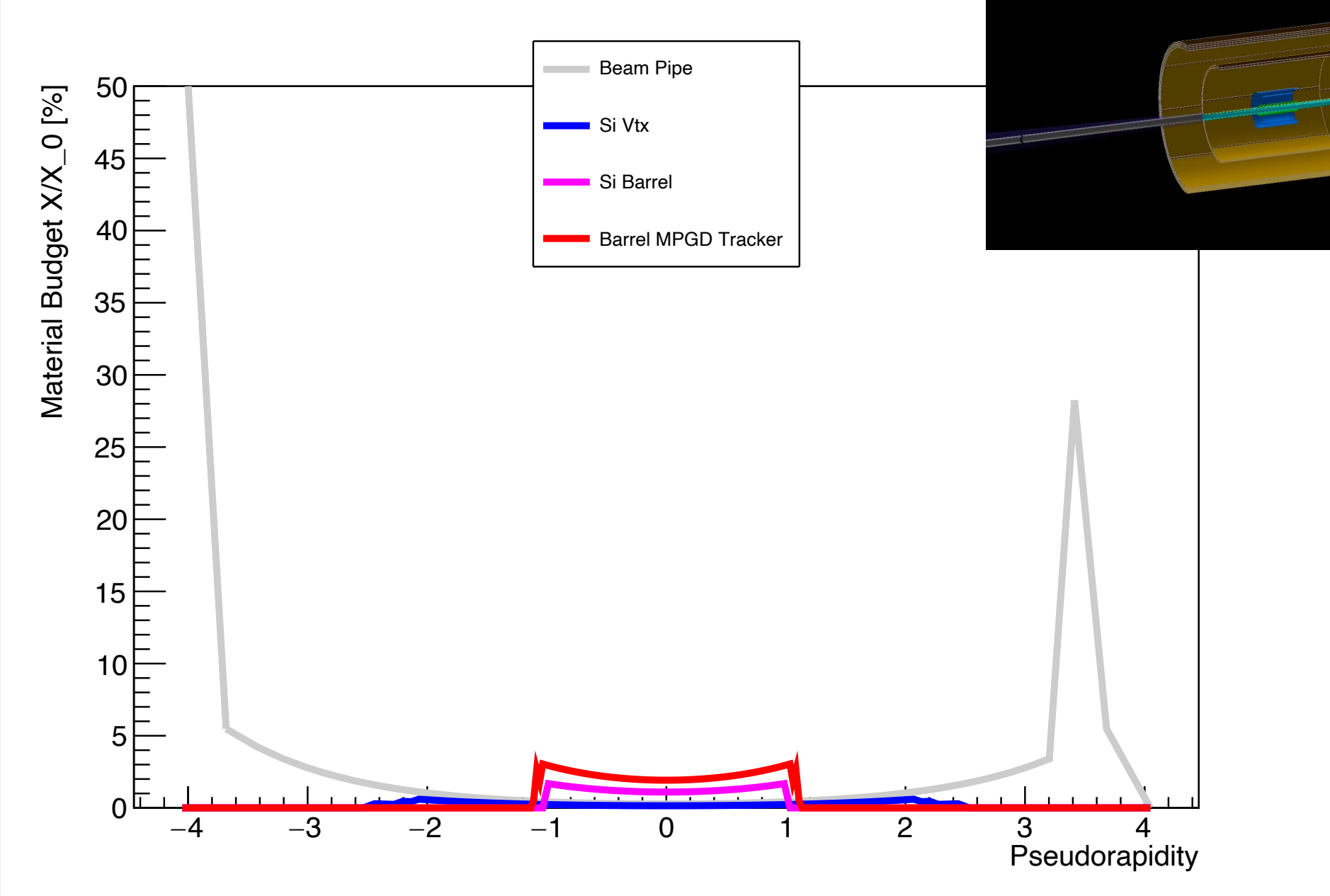

Material Scan

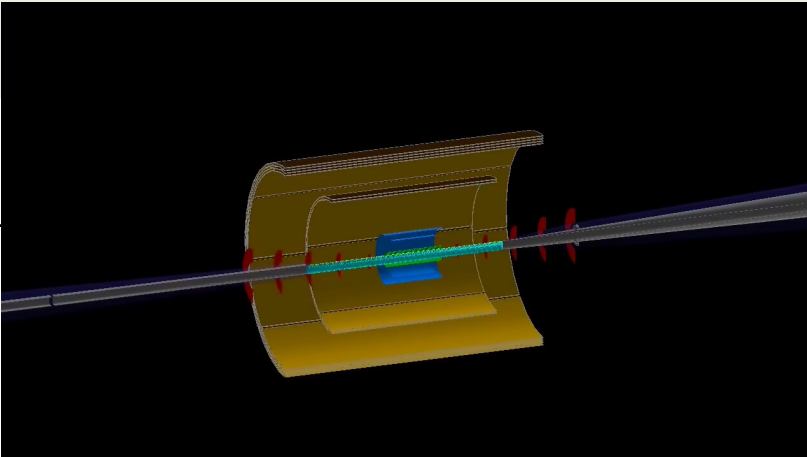
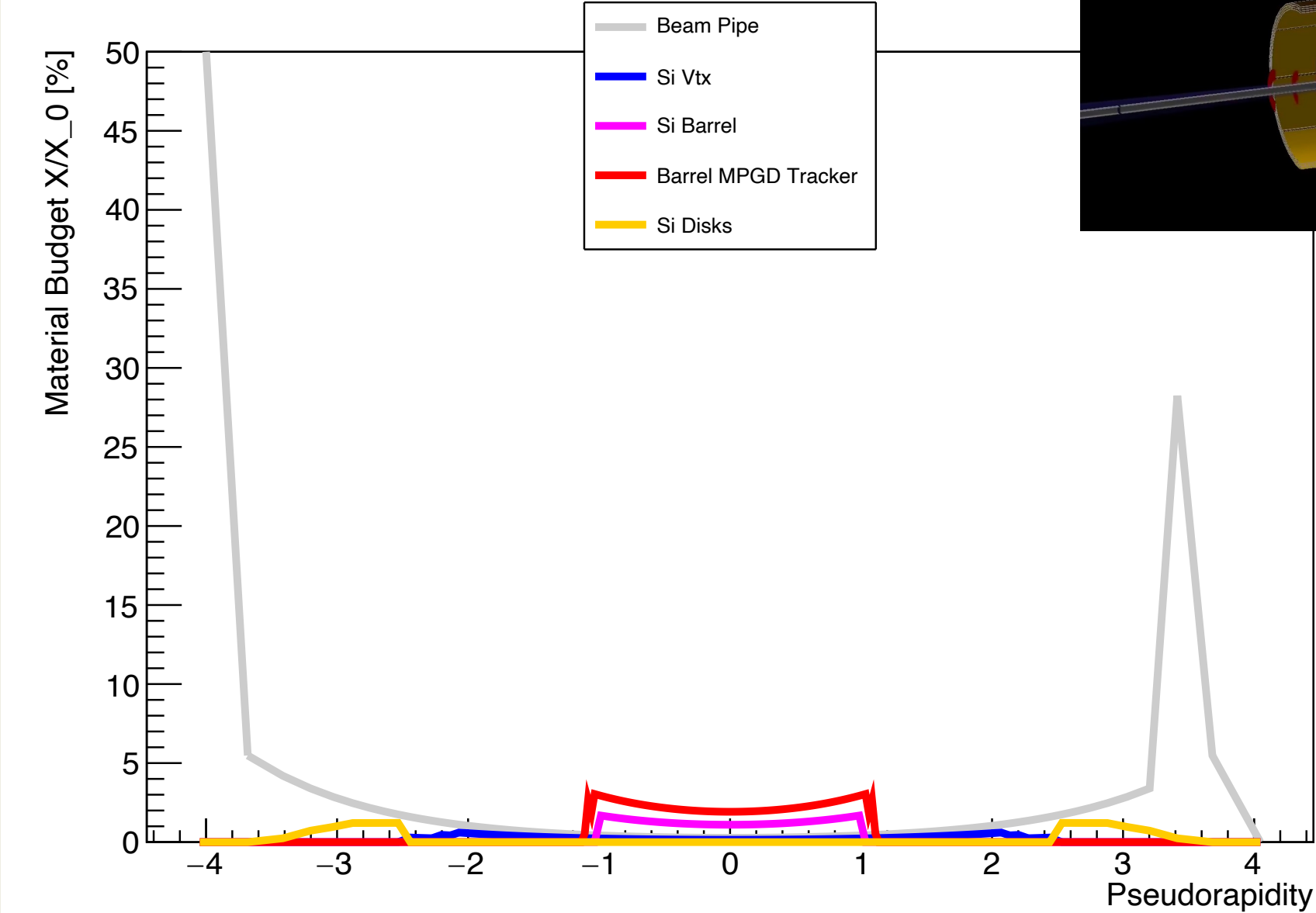

Material Scan

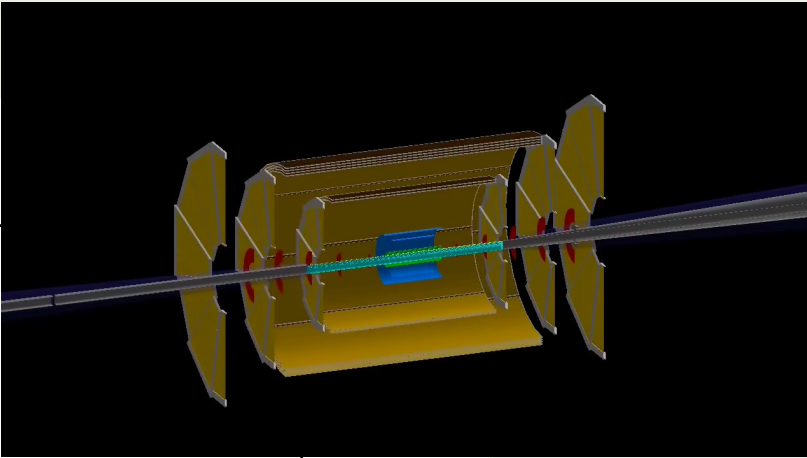
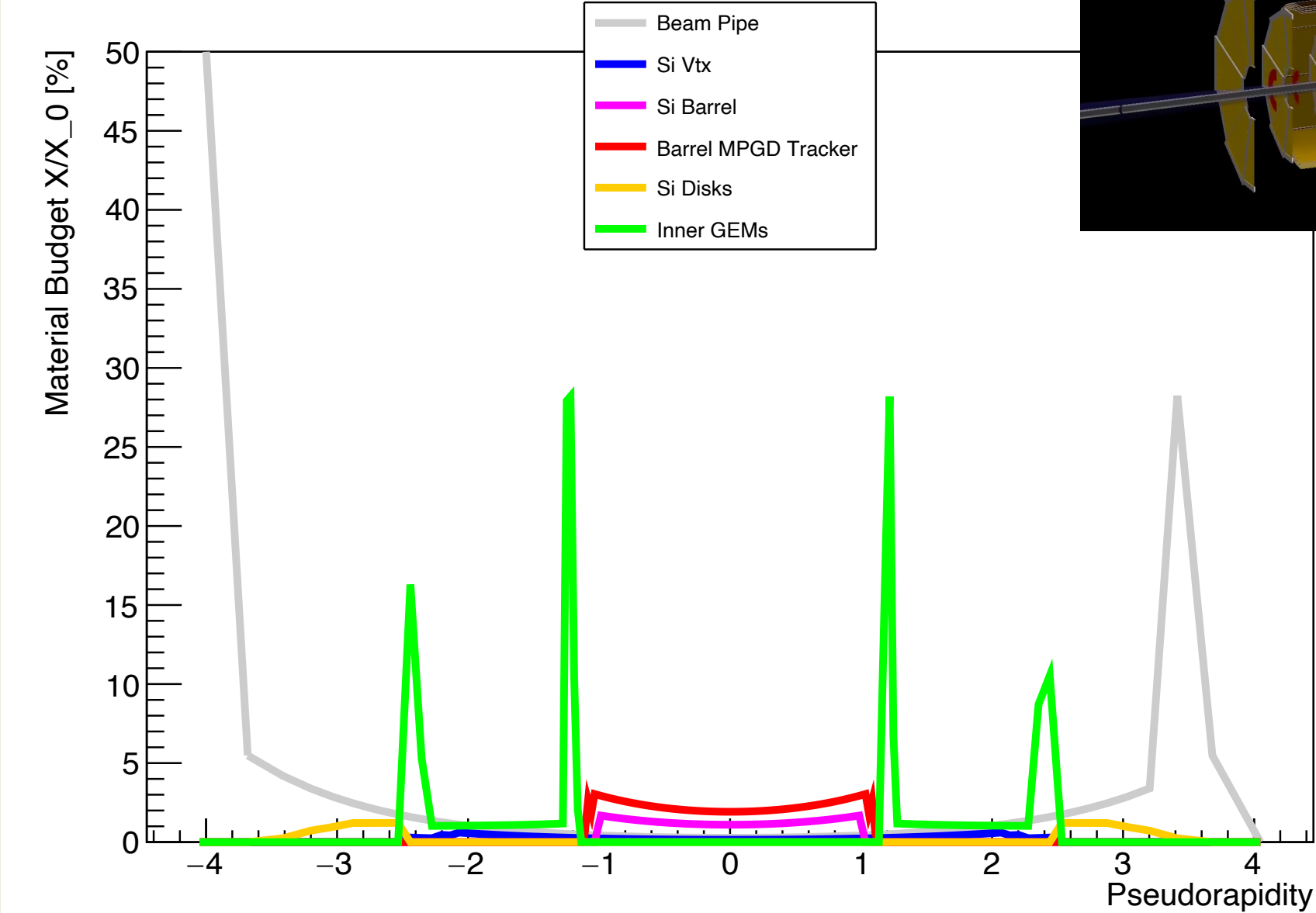

Material Scan

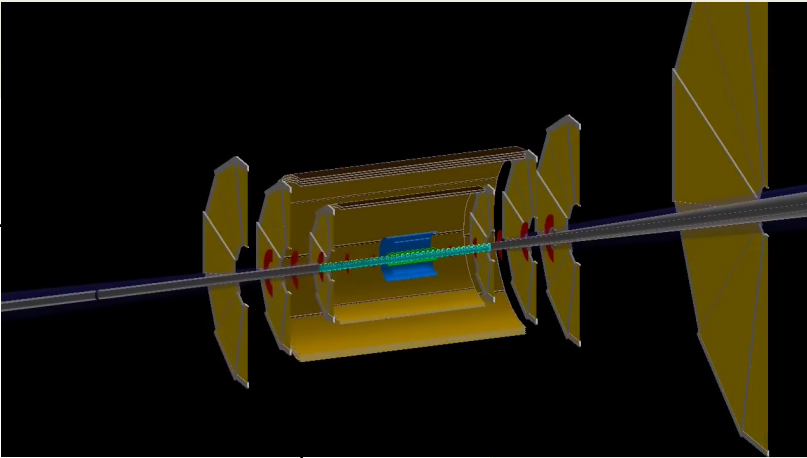
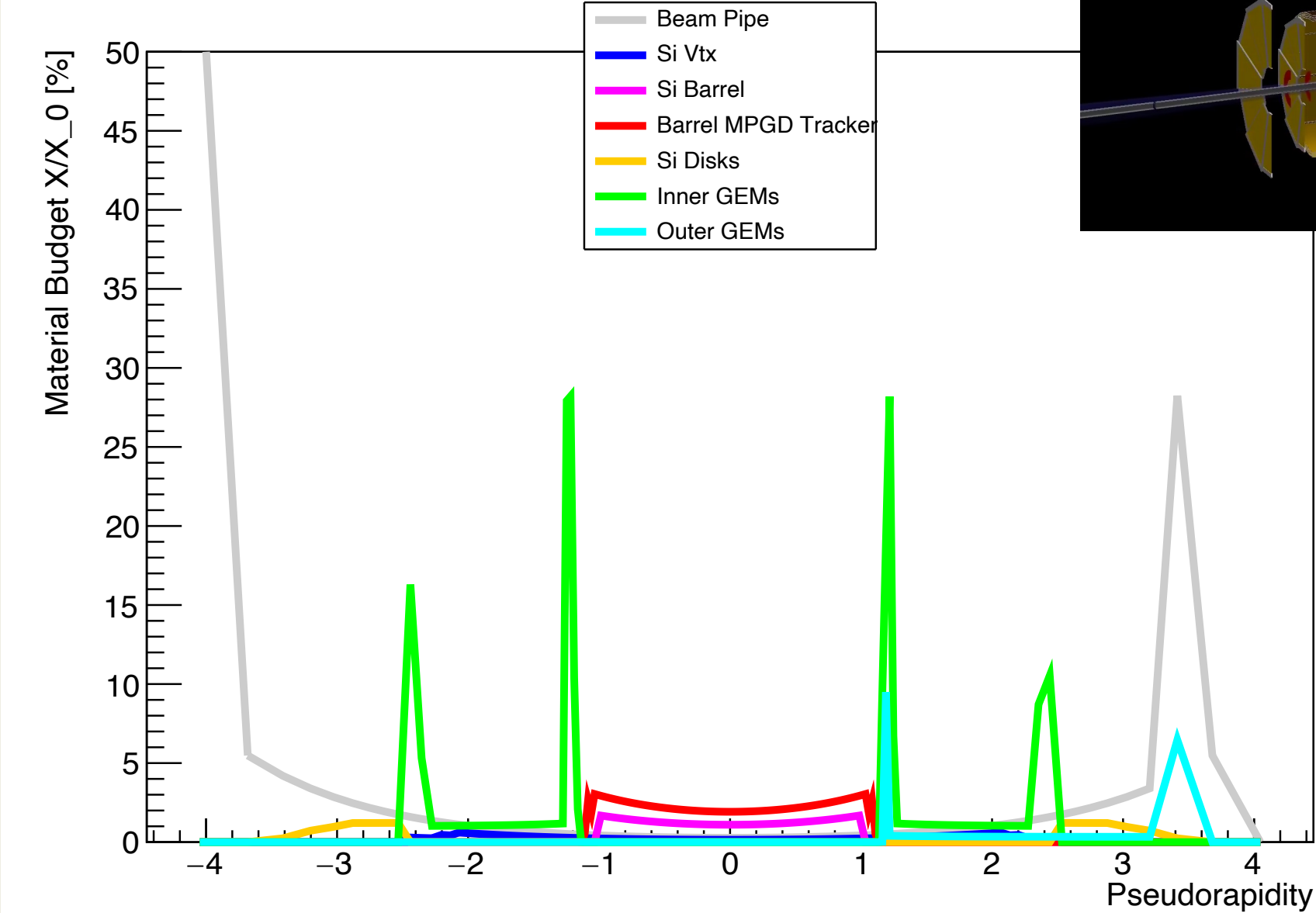

Material Scan

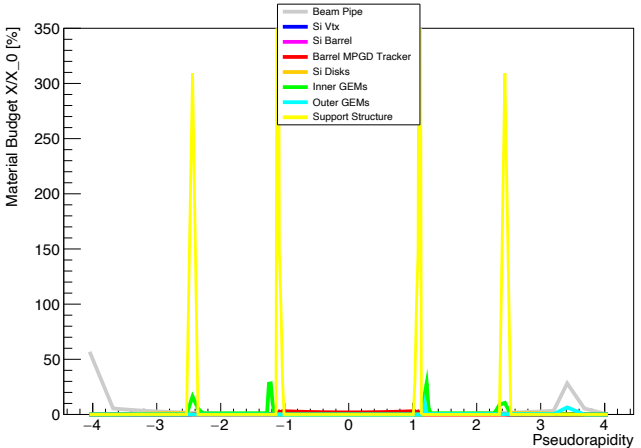
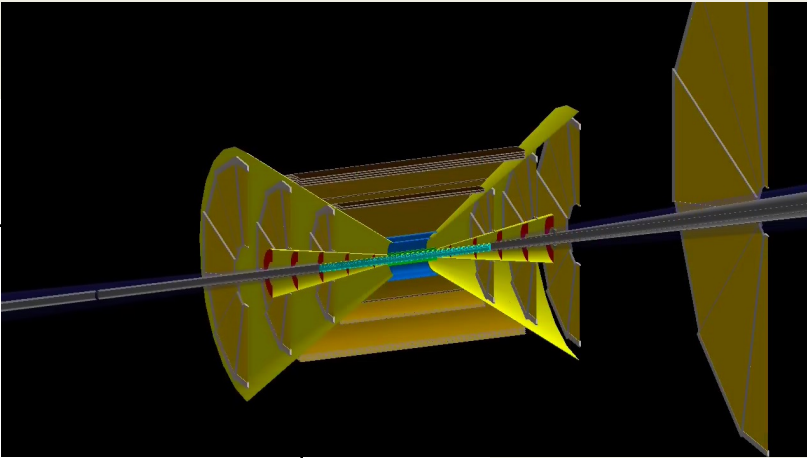
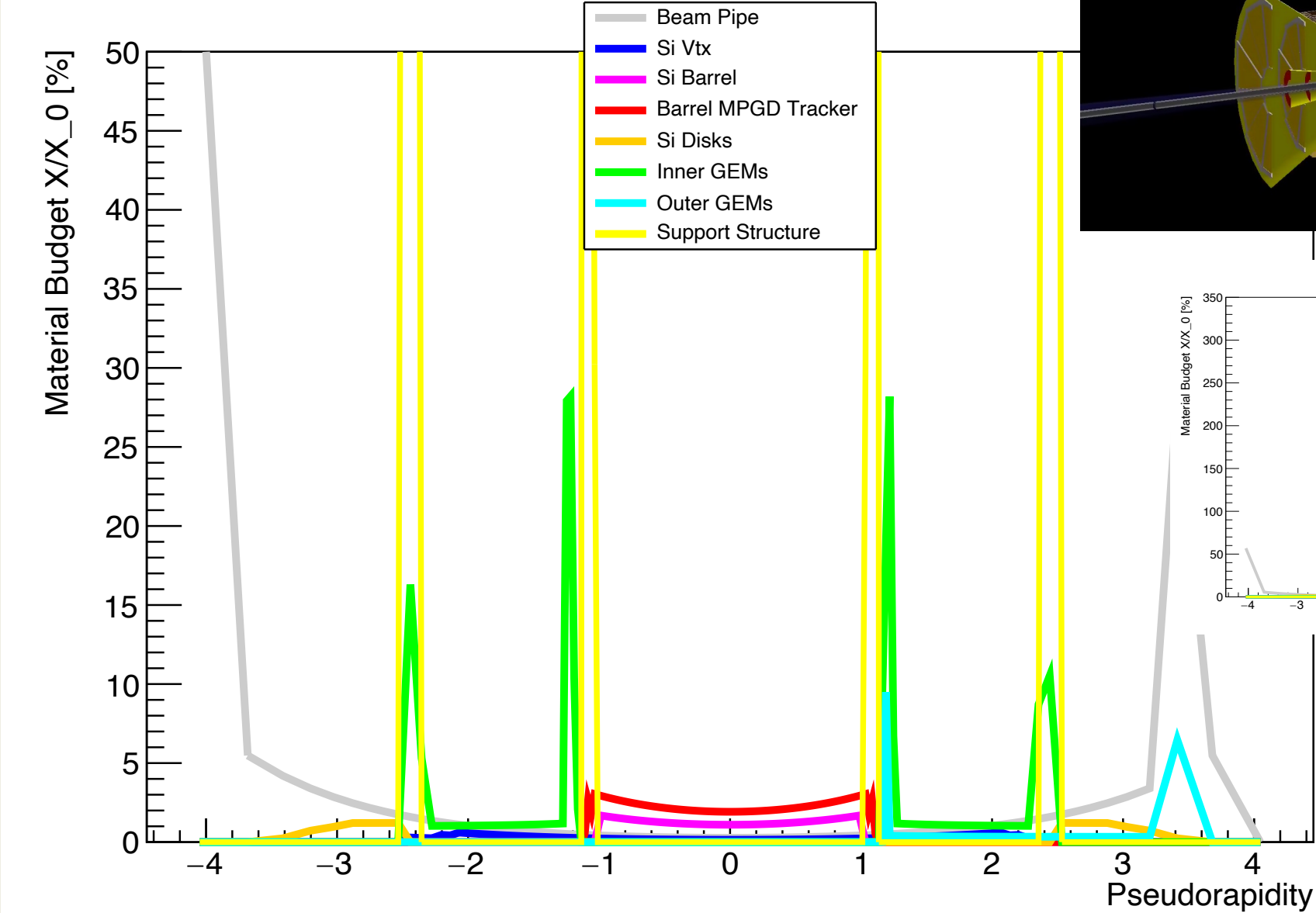

Material Scan

