

# AC-LGAD TOF for ATHENA

Zhenyu Ye

University of Illinois at Chicago

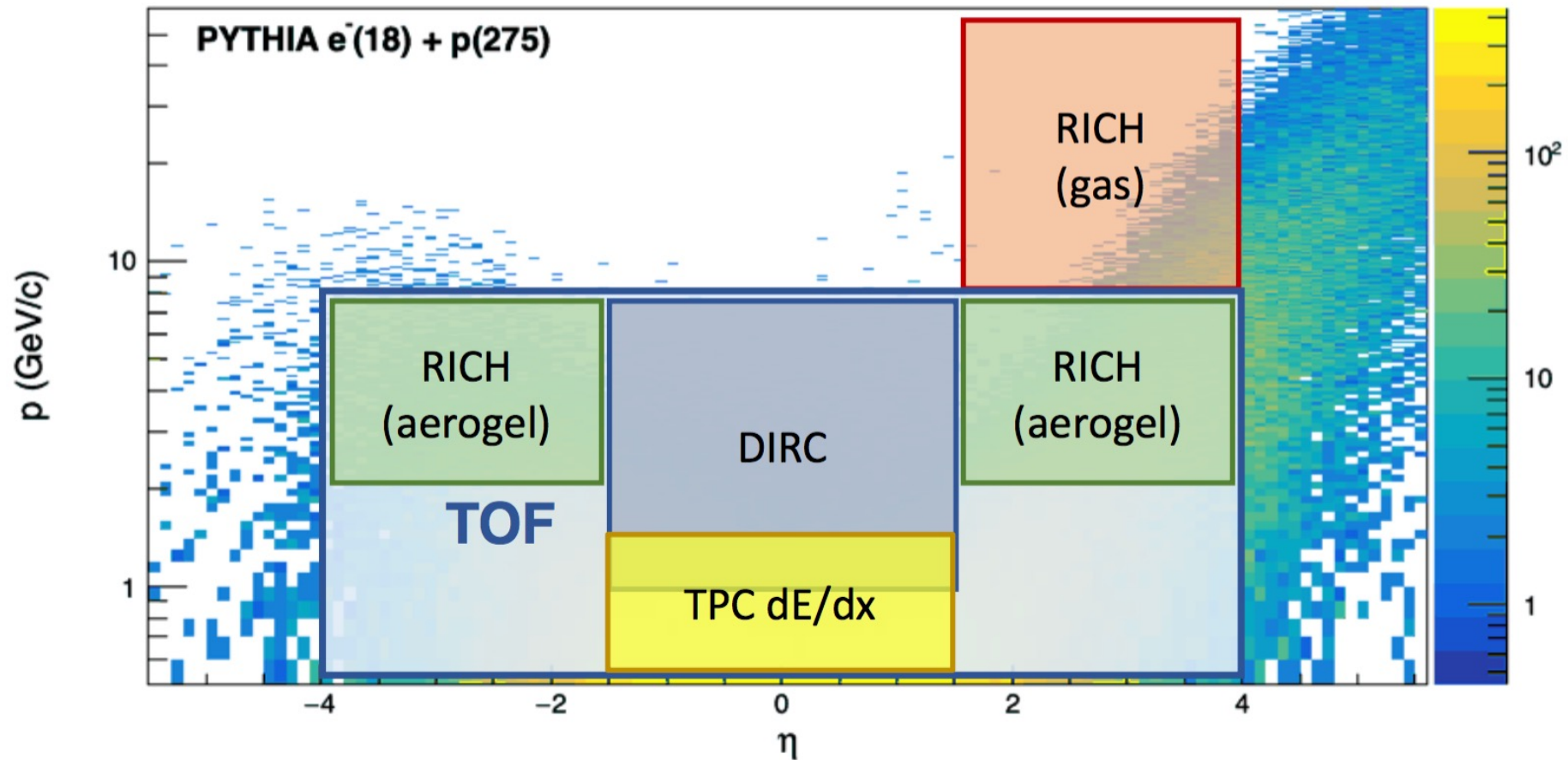

# Low $p_T$ PID for Physics Measurements at EIC

Exclusive  $\phi$  (Z. Tu)

$\Lambda_c$  (W. Fan)

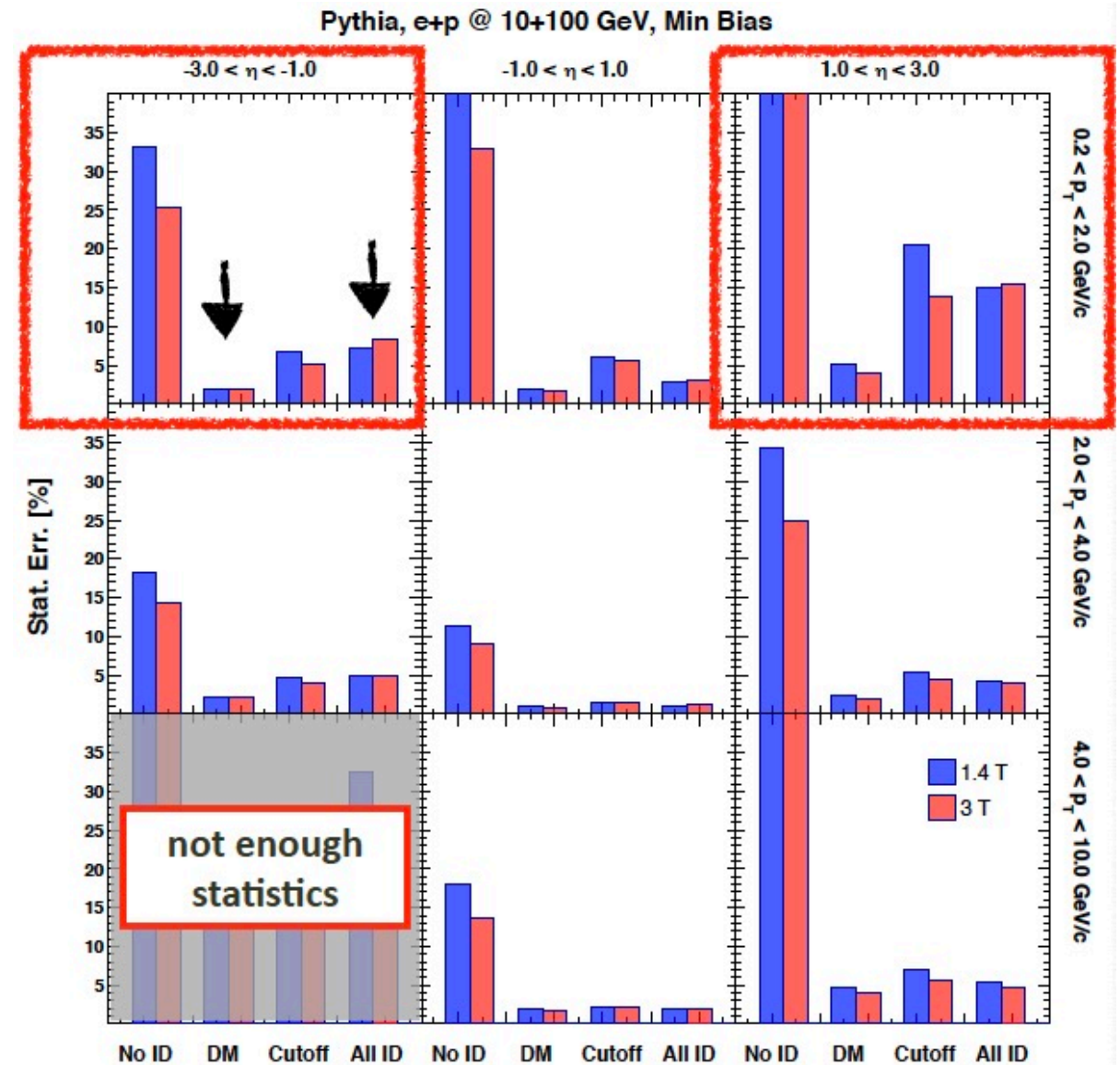
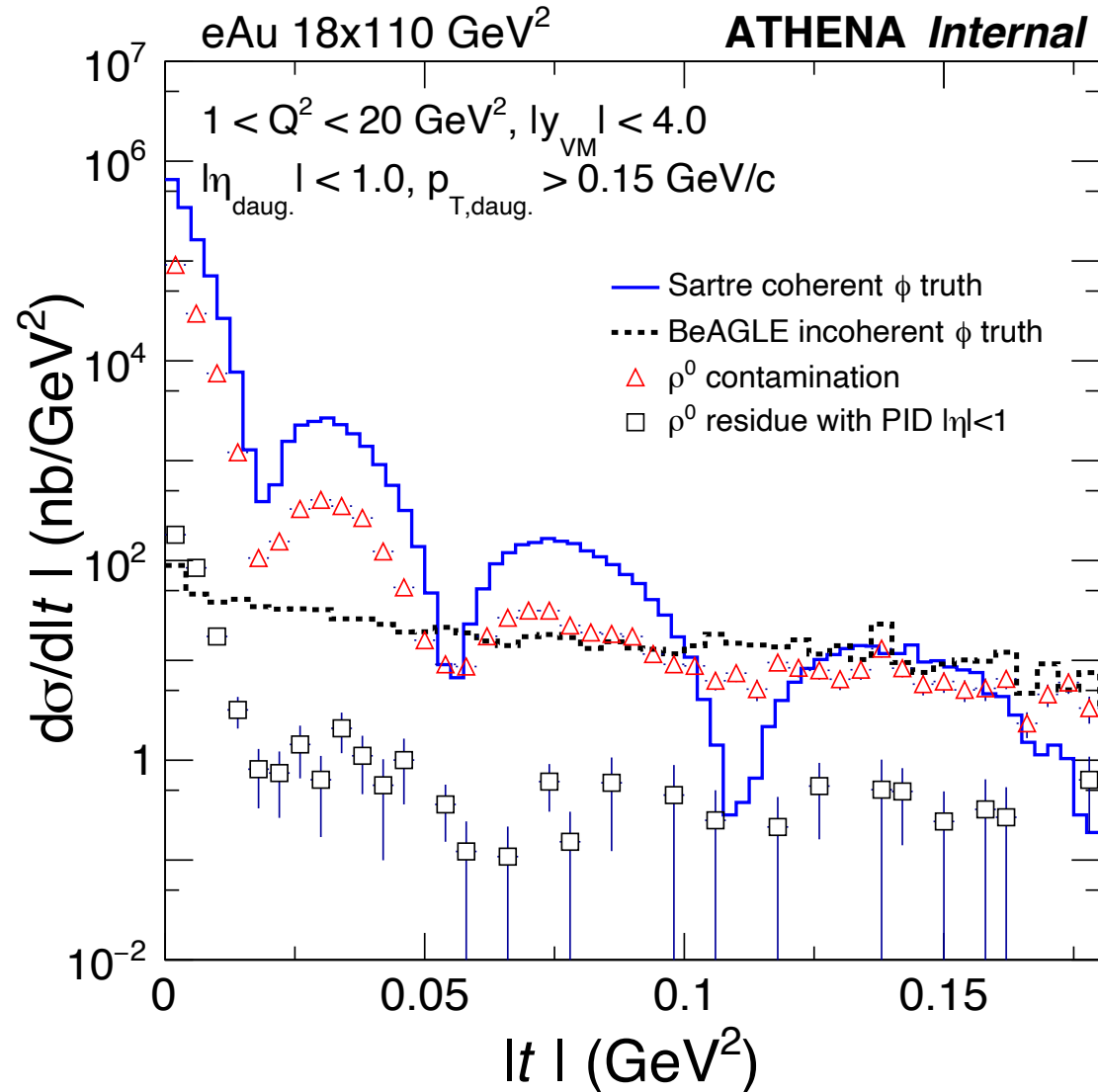

# AC-LGAD for EIC

- Large area LGAD detectors are being built by ATLAS (6.4 m<sup>2</sup>) and CMS (15.6 m<sup>2</sup>) for data taking starting in 2026.
- AC LGAD detectors proposed for EIC
  - Roman Pots and B0
  - TOF for PID (and tracking)
- Have common designs in sensor, ASIC etc. when possible, combine R&D efforts

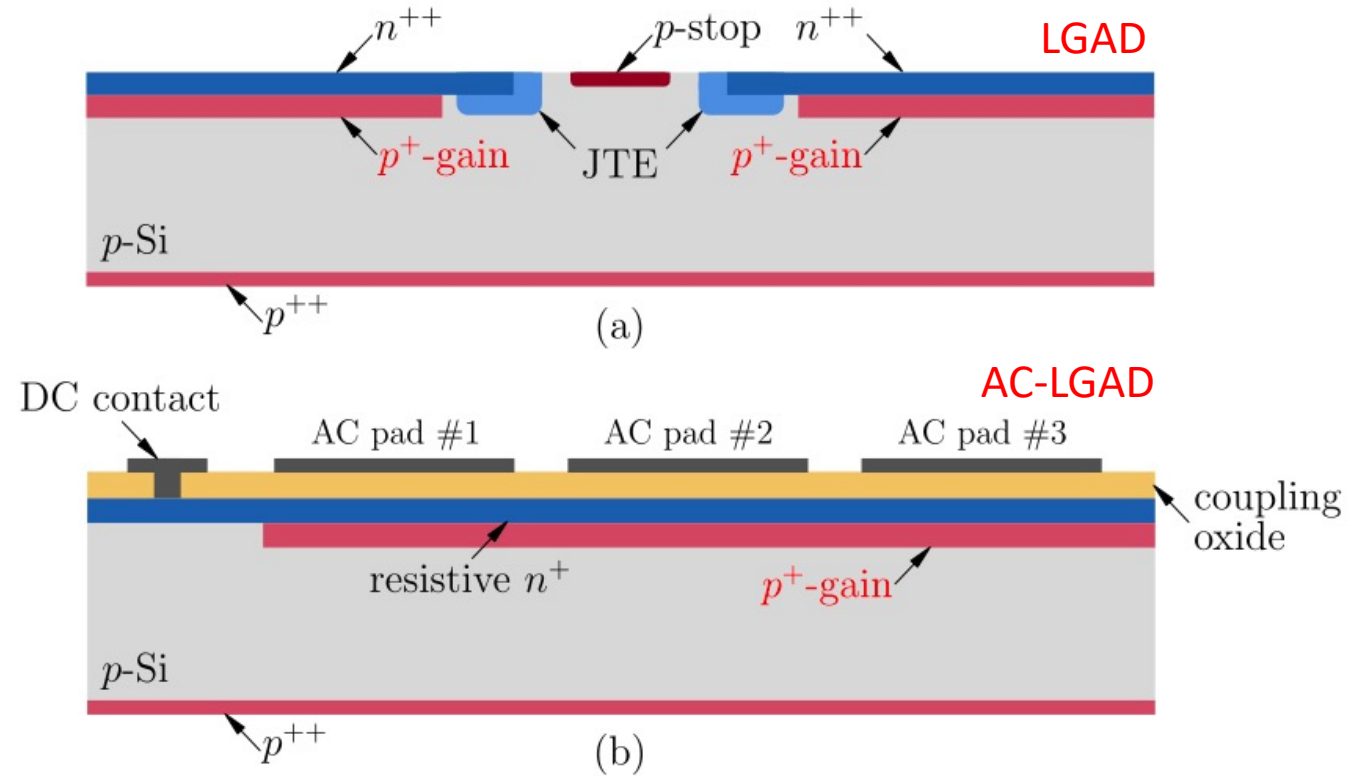

	Time resolution / hit	Position resolution / hit	Material budget / layer
Barrel ToF (Tracker)	<30 ps	(3-30 $\mu\text{m}$ for Tracker)	< 0.01 $X_0$
Endcap ToF (Tracker)	<25 ps	(30-50 $\mu\text{m}$ for Tracker)	e-direction < 0.05 $X_0$ h-direction < 0.15 $X_0$
Roman Pots	<50 ps	< 500/ $\sqrt{12}$ $\mu\text{m}$	N/A
B0	<50 ps	$O(50)$ $\mu\text{m}$	< 0.01 $X_0$

# Sensor R&D

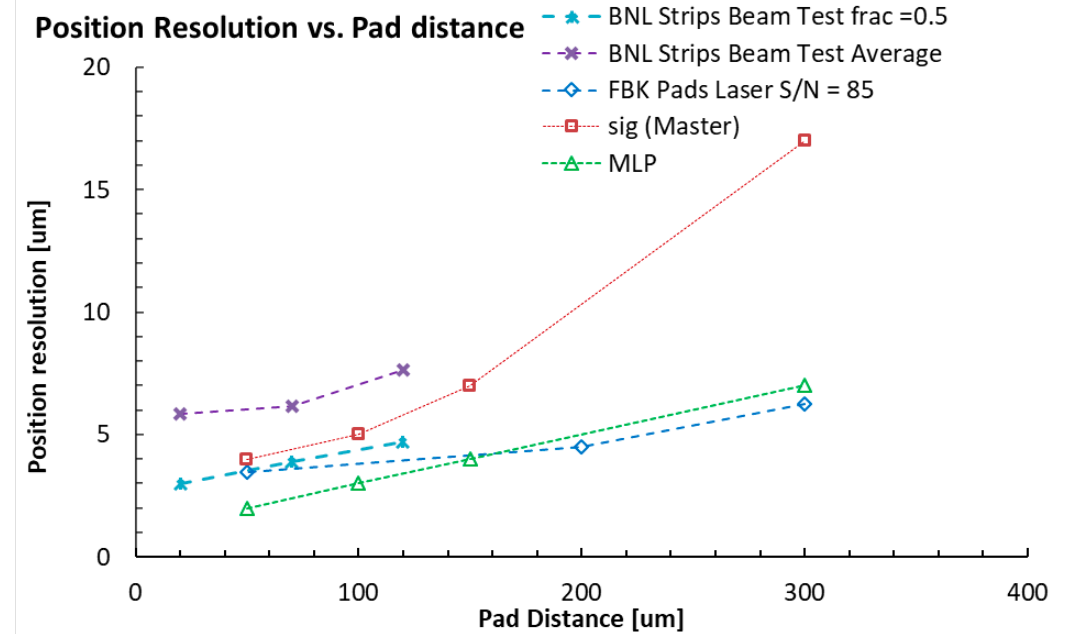
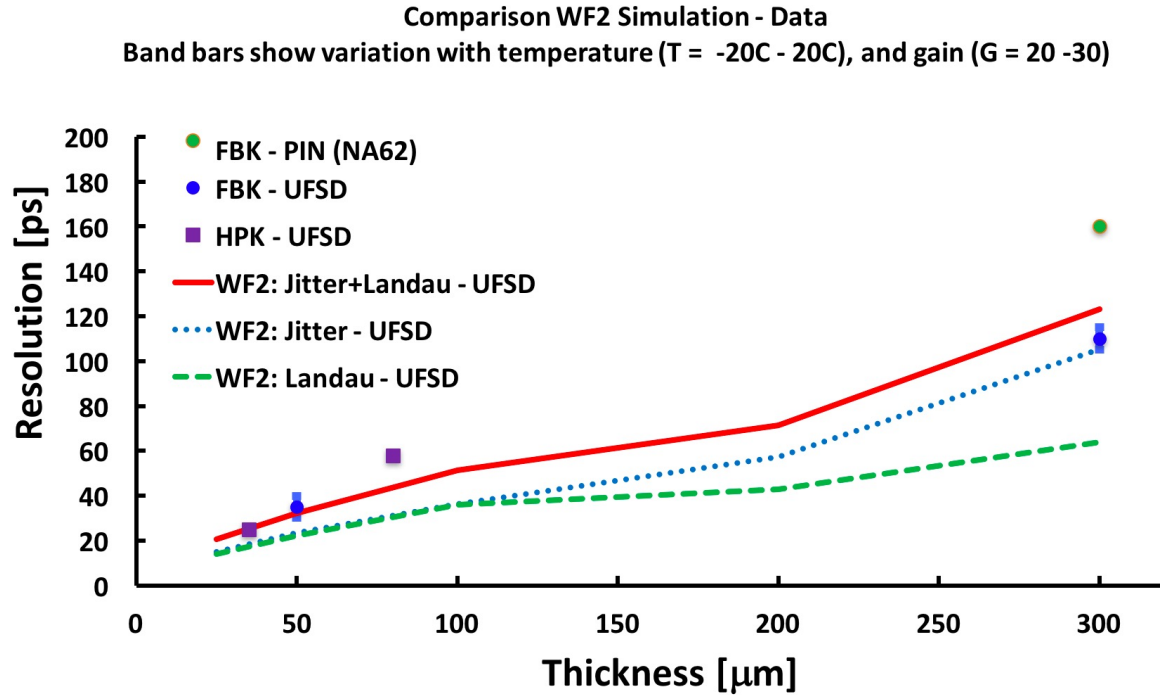

- **R&D Goals**

- 15-20 ps timing resolution,  $O(3-50\mu m)$  position resolution where needed
- Minimal readout channel density (long strip, rectangular pixel) for reduced power and thus material and cost

- **Plan**

- Produce and test sensors with thinner active volume to achieve the desired timing resolution
- Optimize implantation parameters and AC-pad segmentation through simulation and real device studies
- Engage commercial vendors to improve fabrication process and yield

# AC-LGAD TOF Detectors for EIC – eRD112

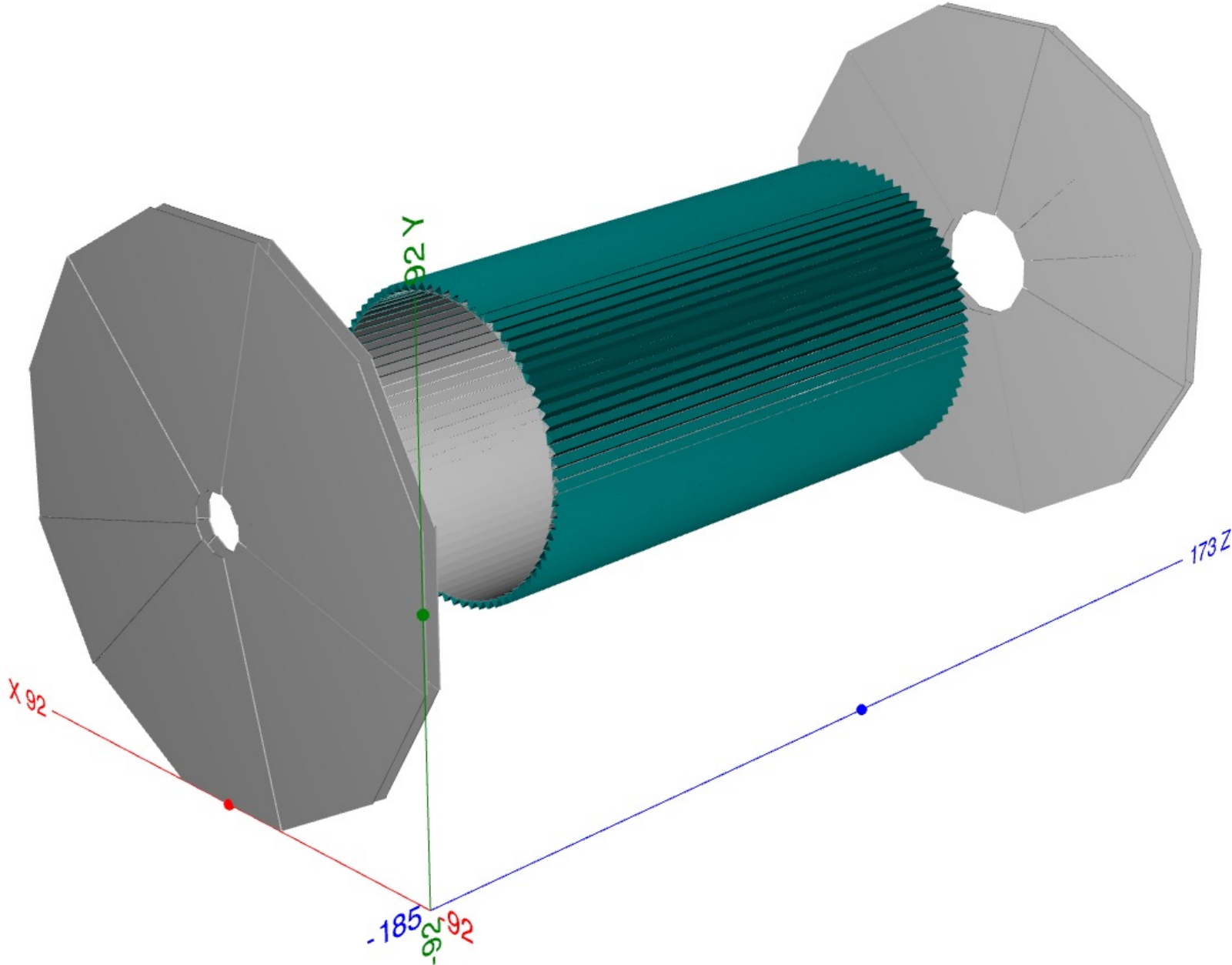

## Barrel TOF

Single layer with 30 ps resolution and  $2\%X_0$  material budget per layer

## Forward TOF

Double layer with 25 ps resolution and  $5\%X_0$  material budget per layer

## Backward TOF

Double layer with 25 ps resolution and  $5\%X_0$  material budget per layer

## START Time

20 ps resolution

# AC-LGAD TOF Detectors in ATHENA DD4HEP

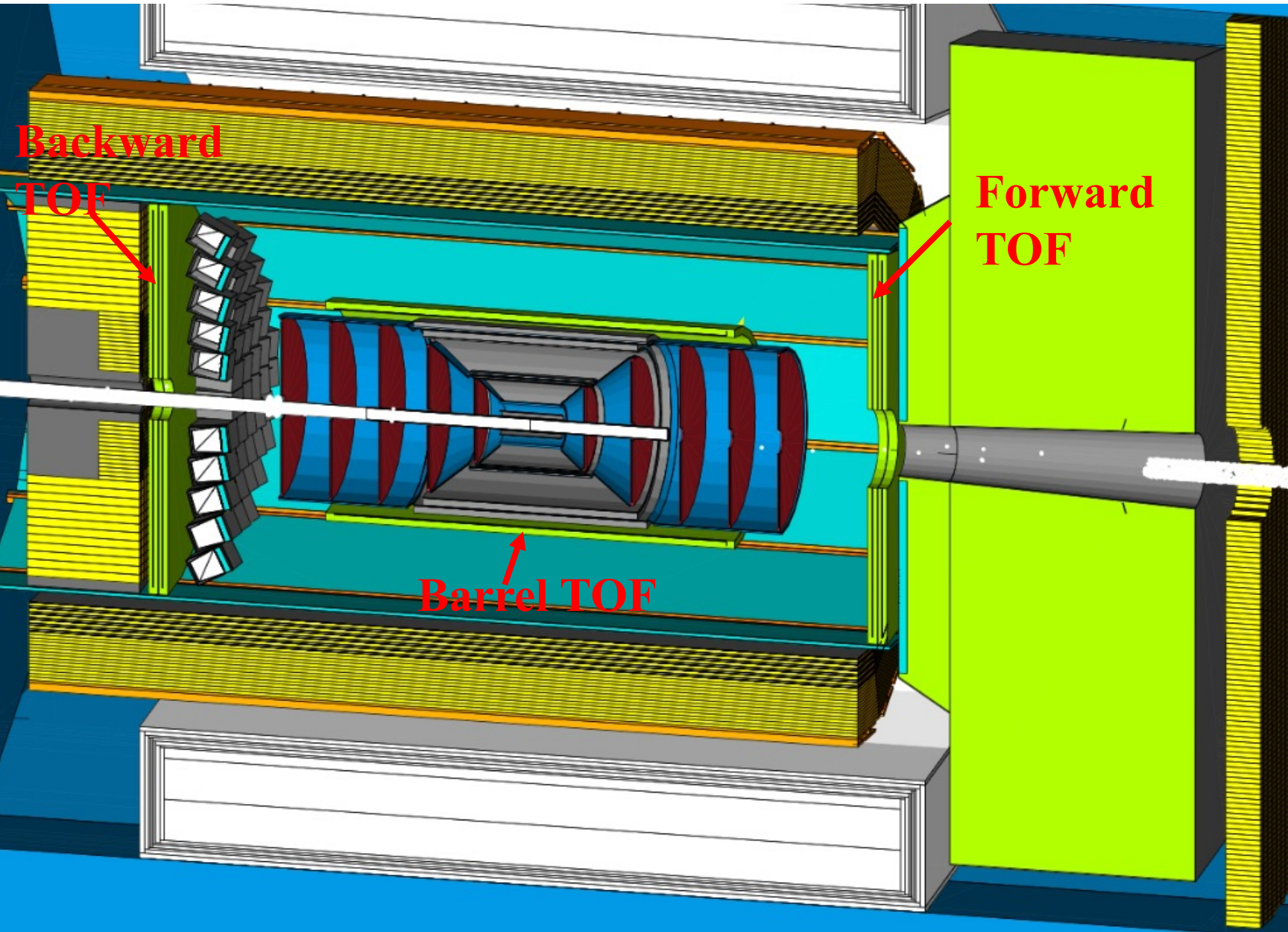

**Barrel TOF** (Area=6.28m<sup>2</sup>)  
Z=[-1m, 1m], R=0.5m,  
Eta=[-1.44, 1.44]

**Forward TOF** (Area=5.44m<sup>2</sup>)  
Z=1.73m, R<sub>in</sub>=0.19m, R<sub>out</sub>=0.95m  
Eta=[1.36, 2.91]

**Backward TOF** (Area=5.44m<sup>2</sup>)  
Z=-1.85m, R<sub>in</sub>=0.19cm, R<sub>out</sub>=0.95m,  
Eta=[-2.97,-1.42]

# Barrel TOF ( $\eta=0$ )

ideal p, L and time

smearing p, ideal L and t

smearing p and L, ideal t

smearing p, L and t

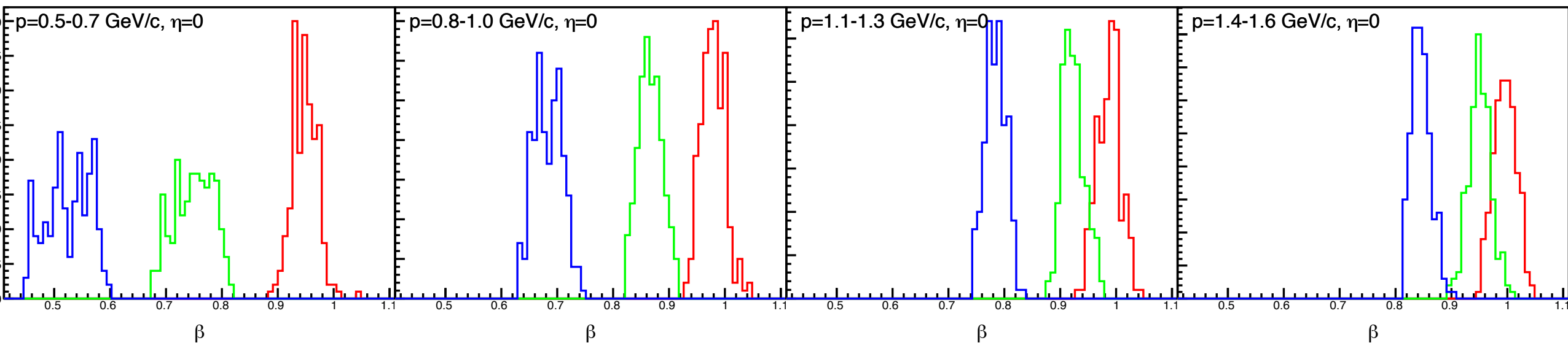
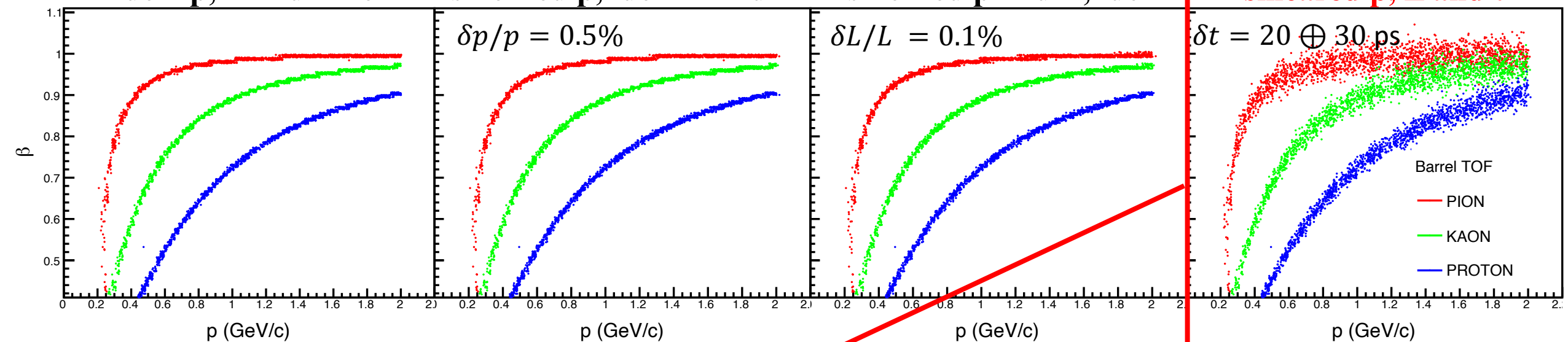

# Forward and Backward TOF ( $\eta = \pm 2.25$ )

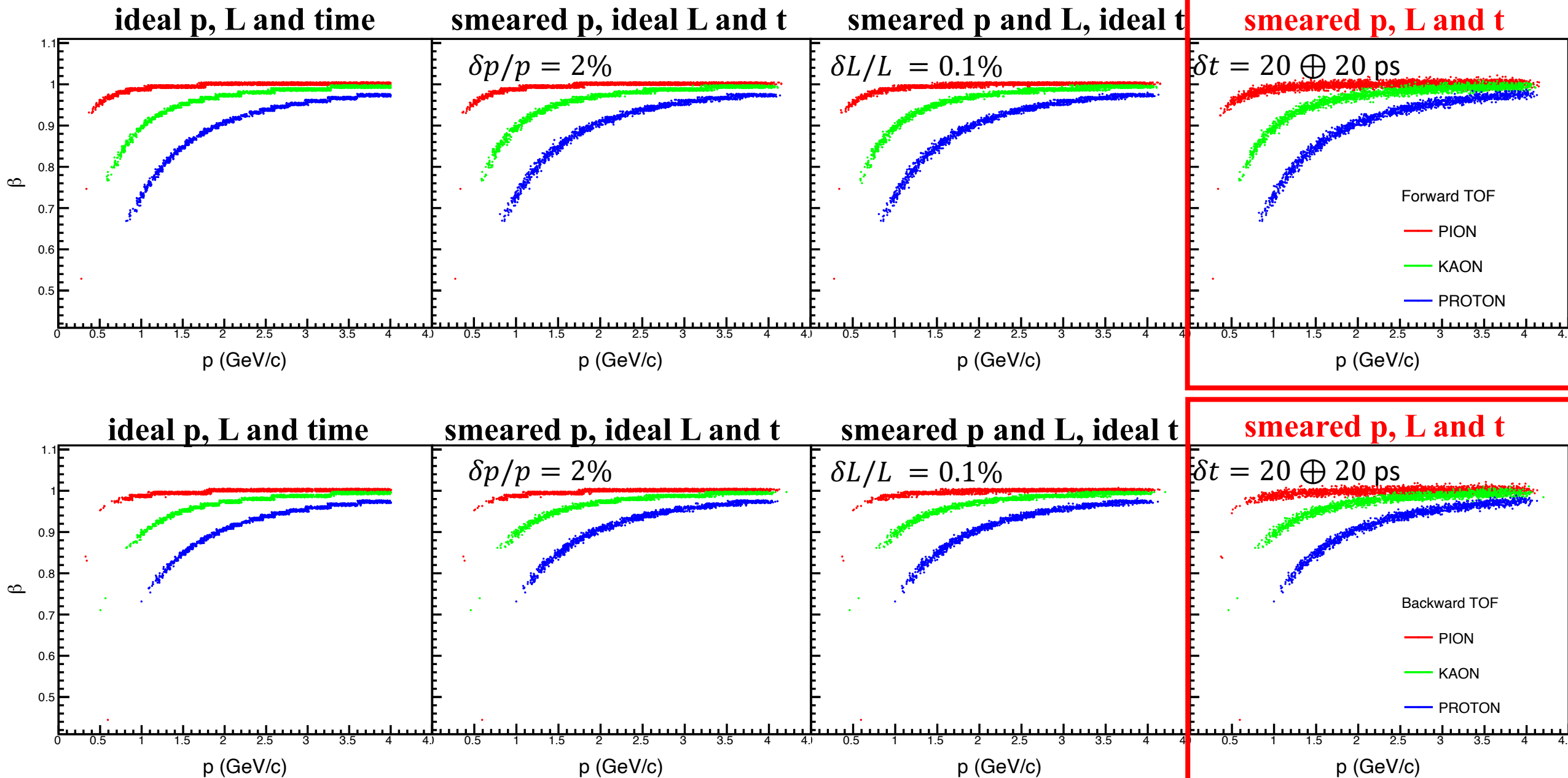



# AC-LGAD Barrel TOF Detector for EIC – STAR IST

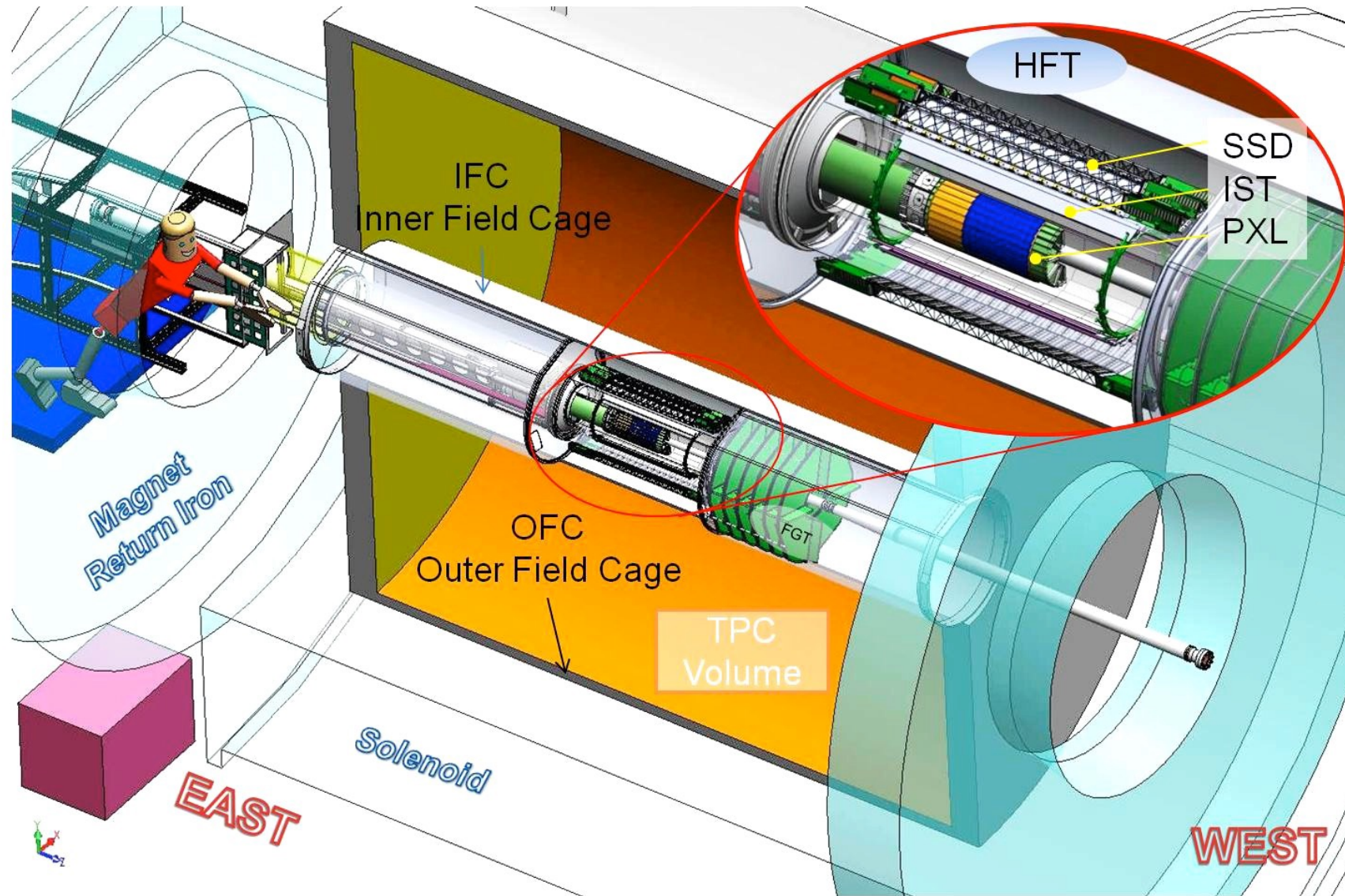

# AC-LGAD Barrel TOF Detector for EIC – STAR IST

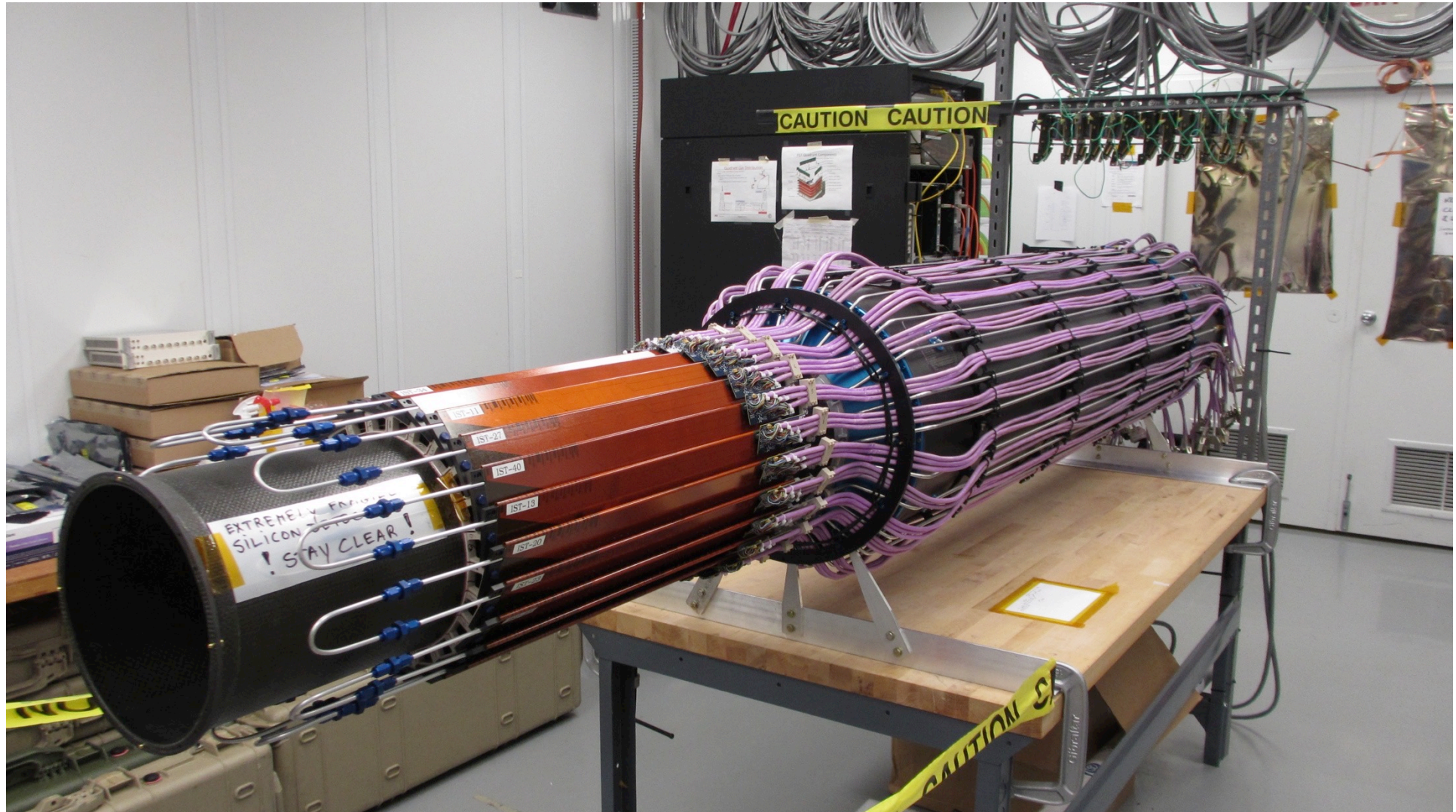

# AC-LGAD Barrel TOF Detector for EIC – STAR IST

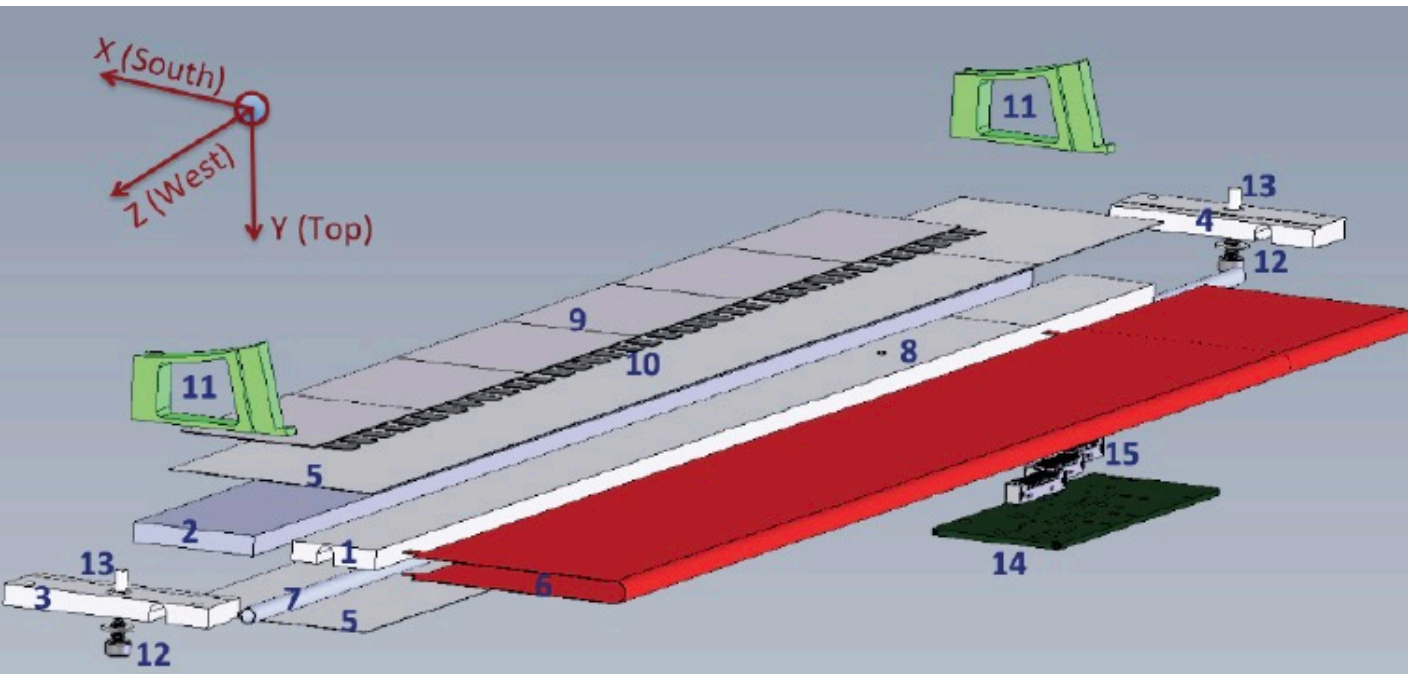
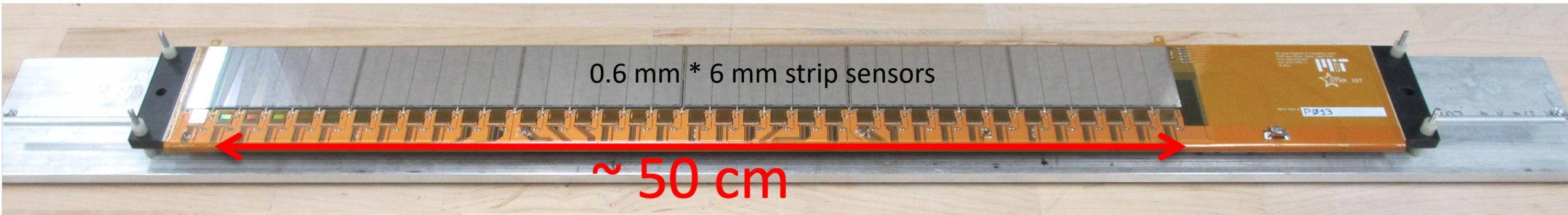

- 1) carbon foam
- 2) carbon honeycomb
- 3) west carbon end-cap
- 4) east Al end-cap
- 5) carbon fiber skins
- 6) Kapton hybrid
- 7) Al cooling tube with cooling liquid inside
- 8) thermal sensor
- 9) silicon sensors
- 10) APV chips
- 11) support blocks
- 12) screws with washers
- 13) spacers
- 14) transition board
- 15) readout connectors.

# AC-LGAD Endcap TOF Detectors for EIC – STAR IST

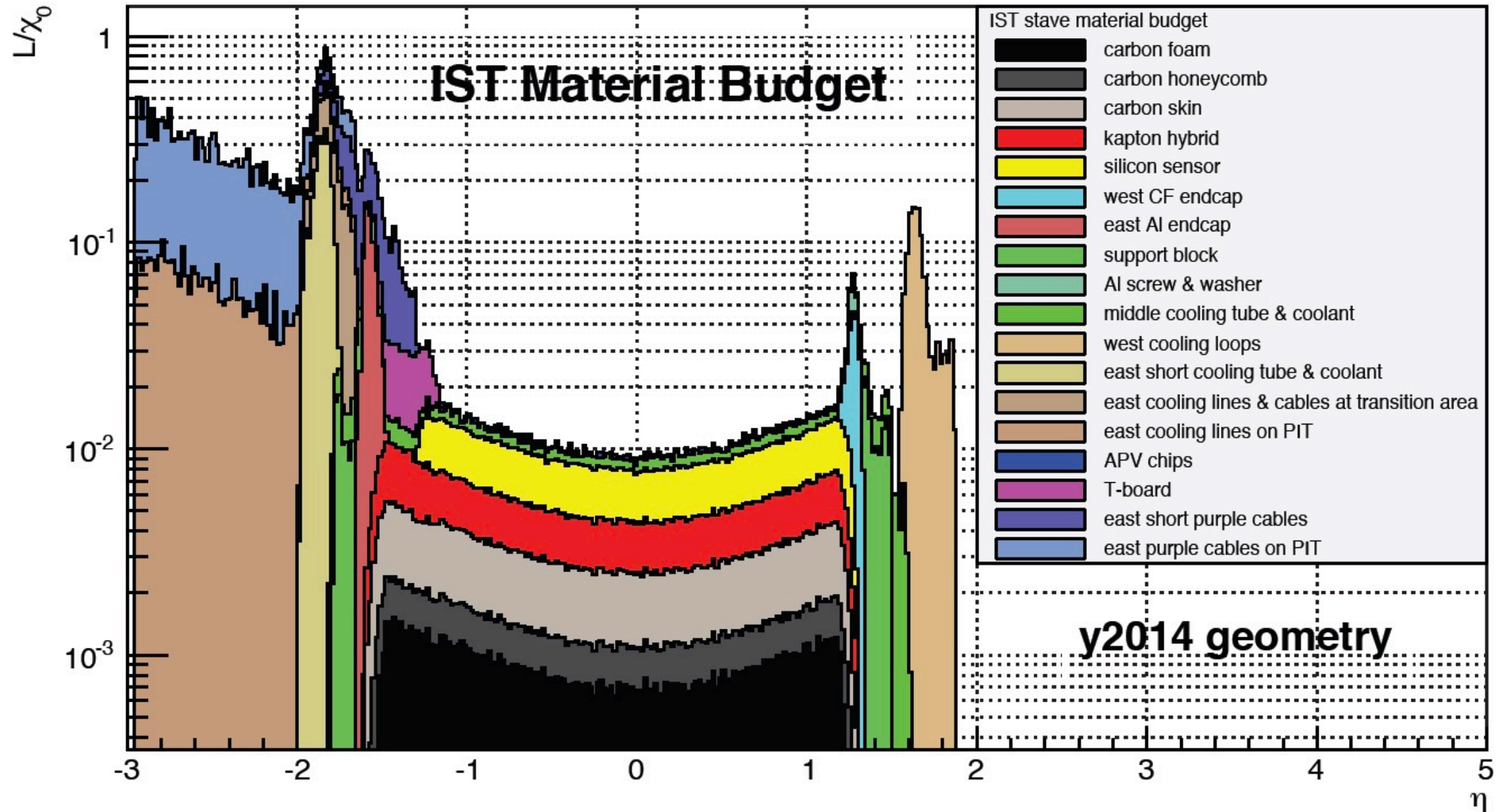

# ATLAS High Granularity Timing Detector (HGTD)

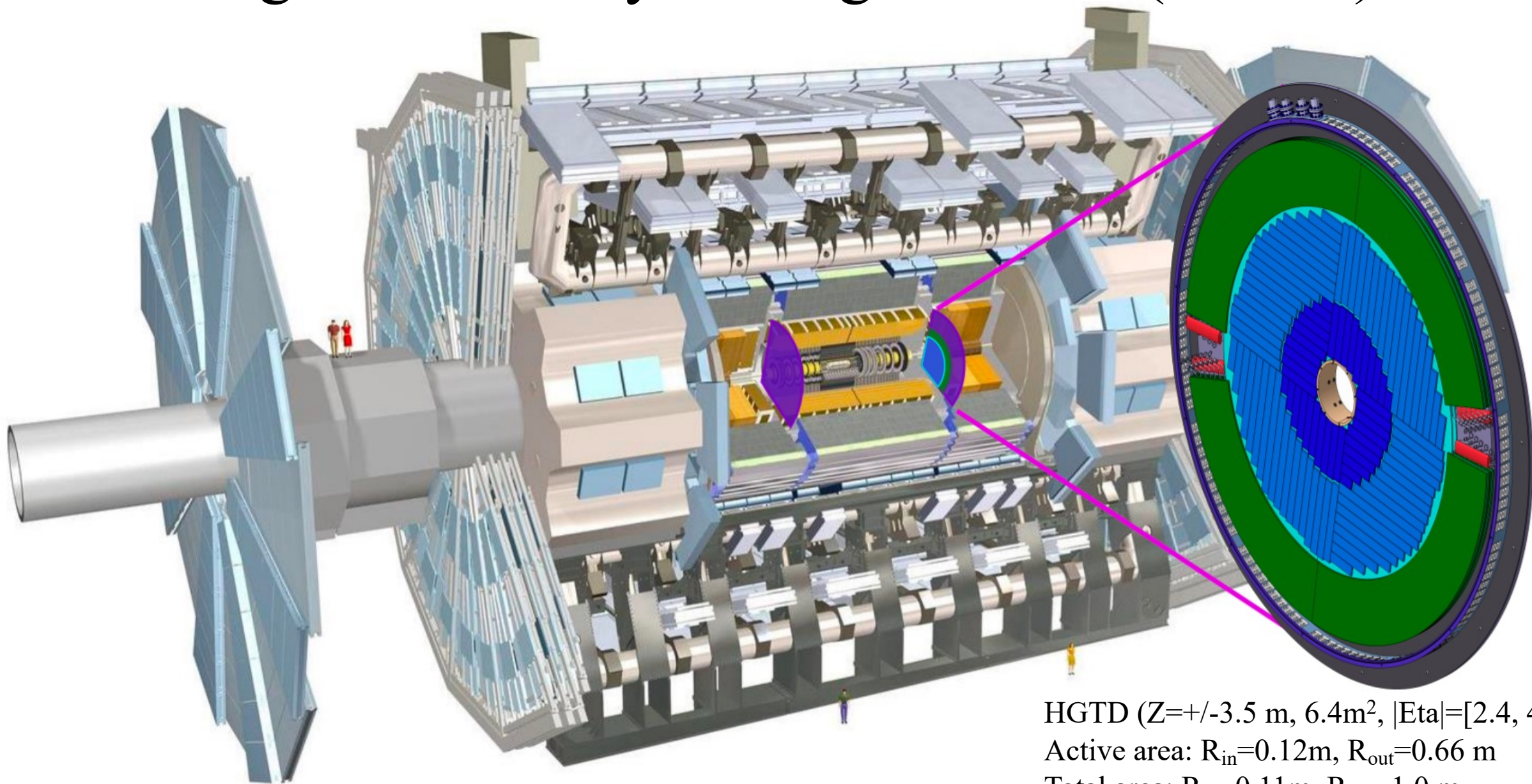

HGTD ( $Z = \pm 3.5$  m,  $6.4\text{m}^2$ ,  $|\text{Eta}| = [2.4, 4]$ )

Active area:  $R_{\text{in}} = 0.12\text{m}$ ,  $R_{\text{out}} = 0.66\text{m}$

Total area:  $R_{\text{in}} = 0.11\text{m}$ ,  $R_{\text{out}} = 1.0\text{m}$

# of channels: 3.6M  $1.3 \times 1.3\text{mm}^2$

# ATLAS High Granularity Timing Detector (HGTD)

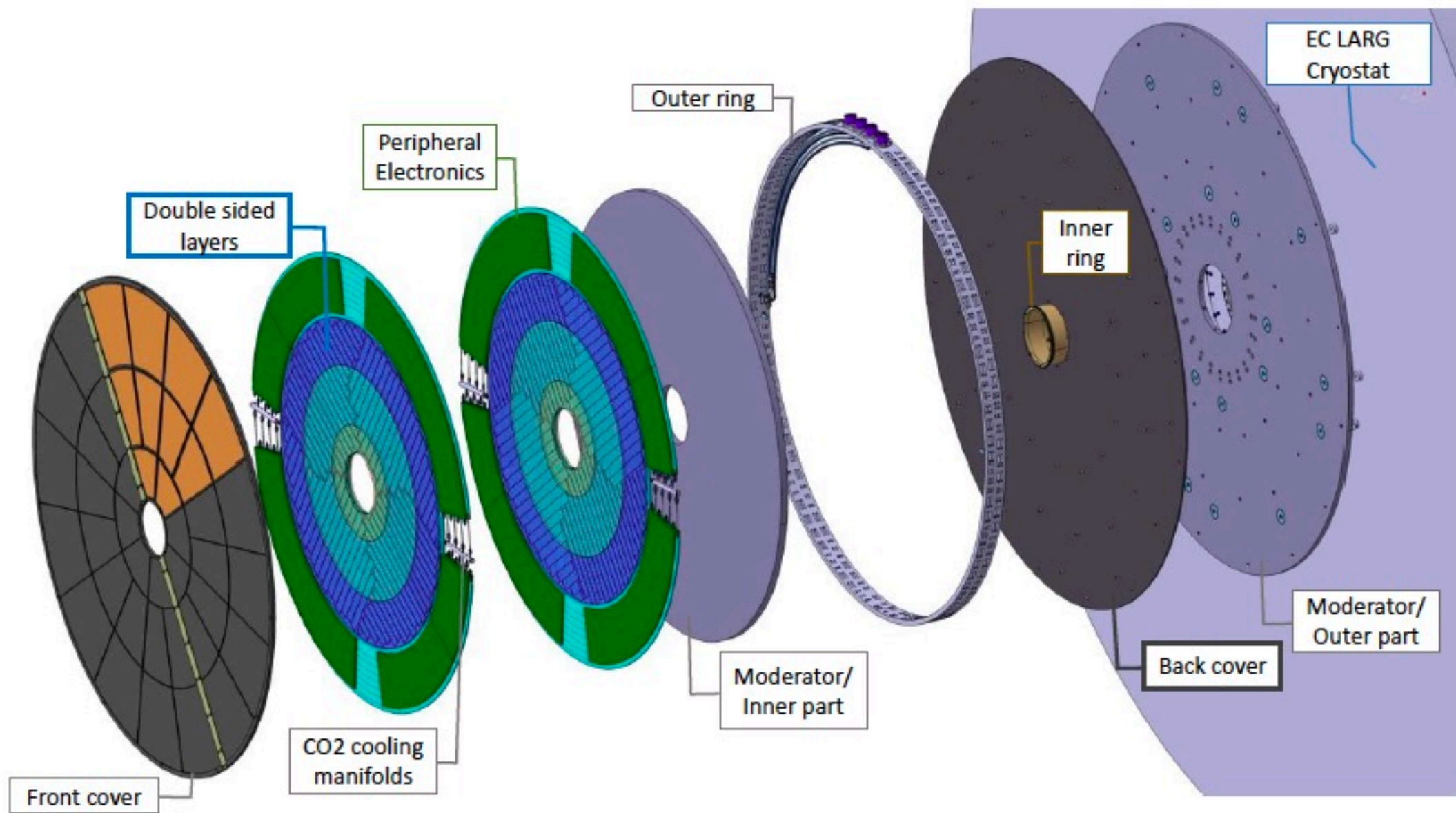

# ATLAS High Granularity Timing Detector (HGTD)

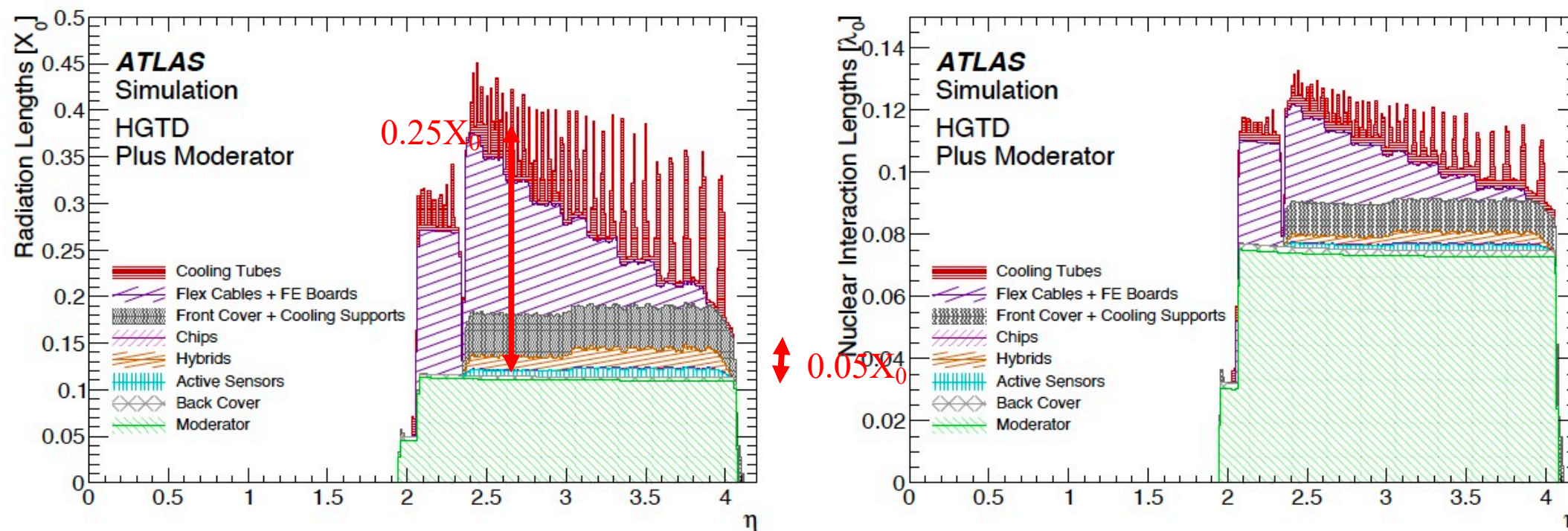
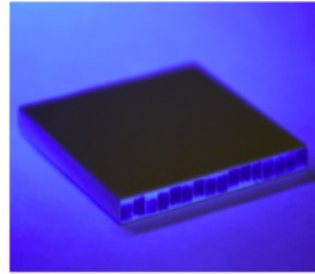

Figure 2.12: Radiation length  $X_0$  (left) and nuclear interaction length  $\lambda_0$  (right) as a function of pseudo-rapidity  $\eta$ , broken down by type of material for the HGTD, using the simulation of the two ring detector geometry described in Section 3.1.1. The moderator is included as it is within the hermetic vessel, although it is situated behind the active area of the HGTD. The baseline cooling pipes will be made with titanium instead of stainless steel as used in the simulation and material plots shown in this figure. The resulting radiation and nuclear interaction lengths will also be reduced with titanium cooling pipes.

# CMS MIP Timing Detector (MTD) - Endcap Timing Layer

## BTL: LYSO bars + SiPM readout:

- TK / ECAL interface:  $|\eta| < 1.45$
- Inner radius: 1148 mm (40 mm thick)
- Length:  $\pm 2.6$  m along z
- Surface  $\sim 38$  m<sup>2</sup>; 332k channels
- Fluence at  $4 \text{ ab}^{-1}$ :  $2 \times 10^{14} n_{\text{eq}}/\text{cm}^2$



## ETL: Si with internal gain (LGAD):

- On the CE nose:  $1.6 < |\eta| < 3.0$
- Radius:  $315 < R < 1200$  mm
- Position in z:  $\pm 3.0$  m (45 mm thick)
- Surface  $\sim 14$  m<sup>2</sup>;  $\sim 8.5$ M channels
- Fluence at  $4 \text{ ab}^{-1}$ : up to  $2 \times 10^{15} n_{\text{eq}}/\text{cm}^2$

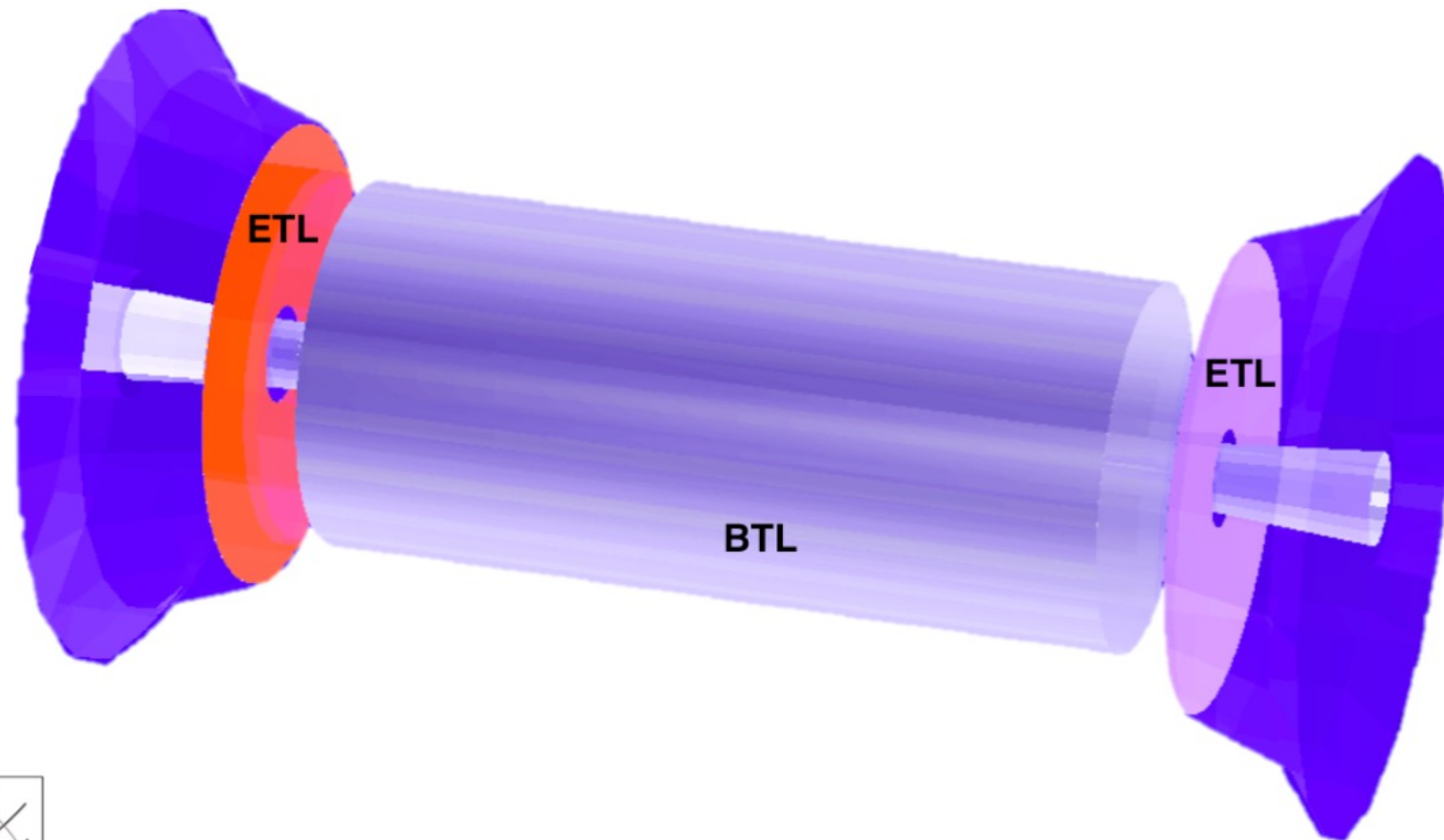
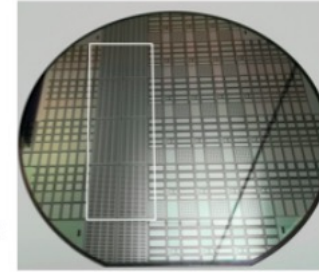



# CMS MIP Timing Detector (MTD) - Endcap Timing Layer

Element	Elements in Z
1	Thermal screen
	Gap between thermal screen and front disc
2	Front face of electronics of the front DEE
3	Front disc
4	Rear face of electronics of the front DEE
	Gap between front and back discs
5	Front face of electronics of the back DEE
6	Back disc
7	Rear face of electronics of the back DEE
	Gap between cables and back disc
8 + 9	Patch panels 0 + cables [9] + moderator [8] at the innermost section
10	Back support plate
	Gap between ETL back support plate and HgCal thermal screen

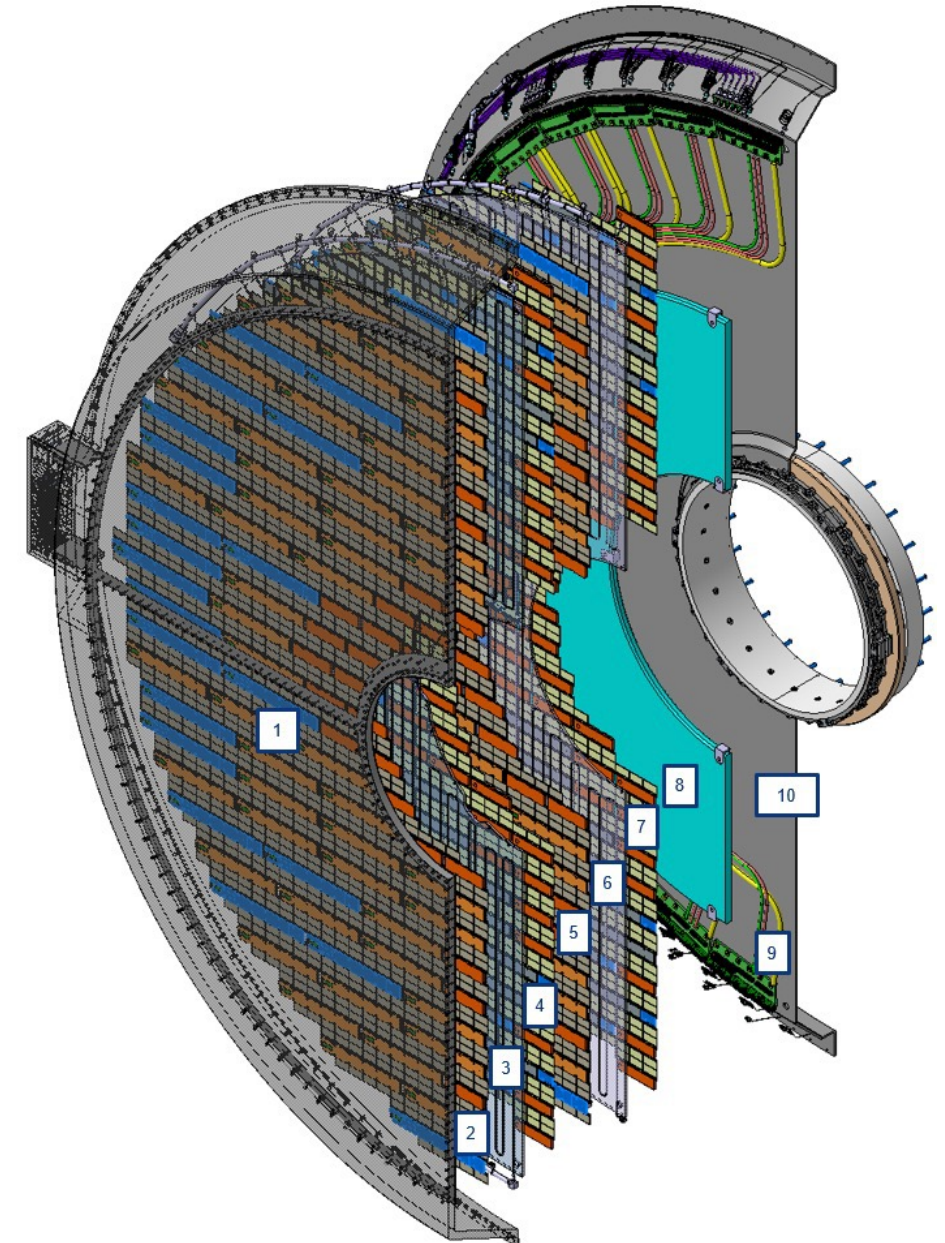

# CMS MIP Timing Detector (MTD) - Endcap Timing Layer

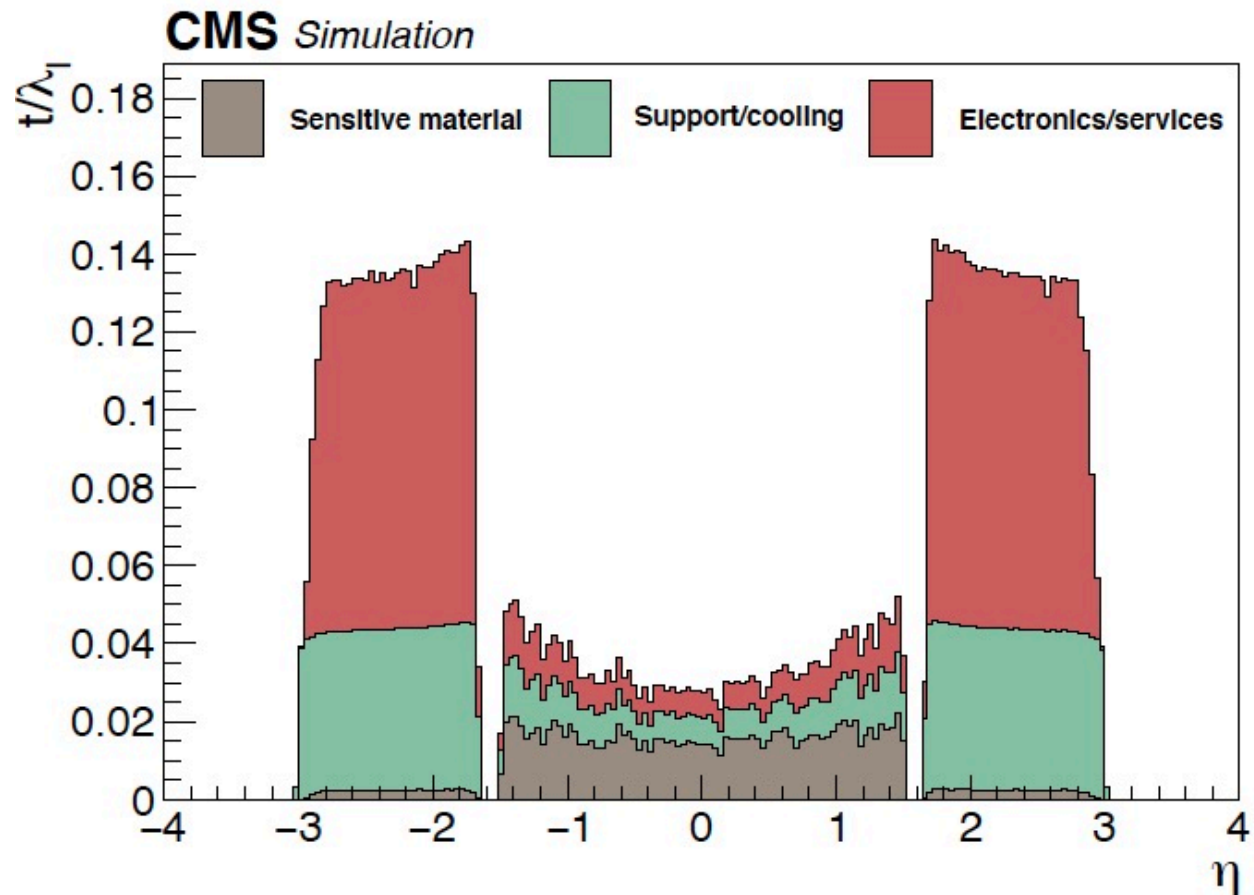
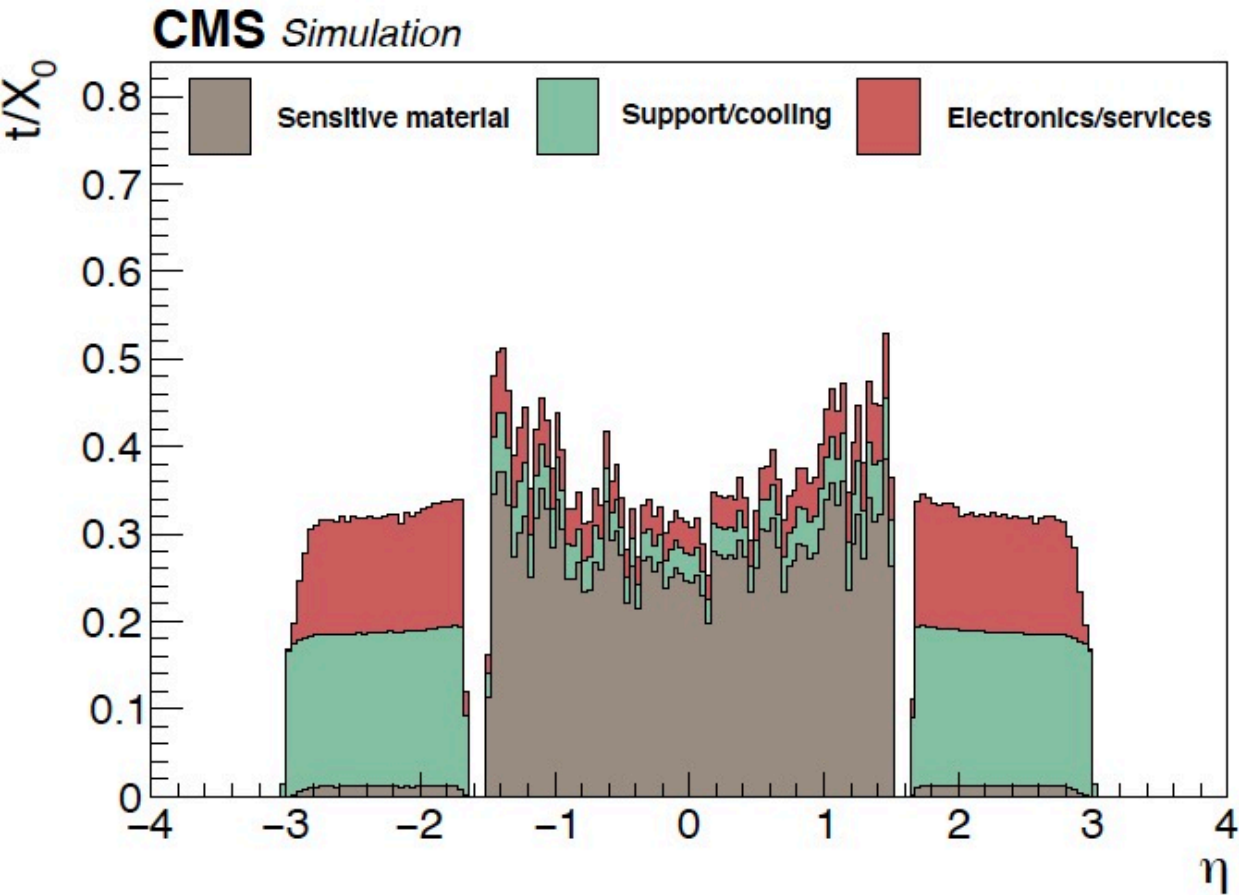

Relative contributions in radiation length

~5% from sensor+ASIC

~20% from module service

~30% from frontend electronics boards

~45% from support structure (Al) and cooling

# AC-LGAD Endcap TOF Detectors for EIC – eRD112

	pixel/strip size (mm*mm)	# of channels per unit area (abs)	Power per channel (mW)
ATLAS/CMS pixels	1.3*1.3	1	4
Long strip – eRD112	0.5*25	1/7.5	1-2
Rectangle pixel – eRD112	0.5*2.6	4/3	1-2

- 1. Much lower irradiation level at EIC than HL-LHC:** Operating AC-LGAD detectors at room temperature (no need for thermal separation from other detectors) without neutron moderator is possible.
- 2. Much smaller multiplicity:** Using long strip sensors and reducing ASIC power consumption per channel. Power consumption density could be reduced by  $\sim 10$ . This will dramatically reduce the service materials (readout boards, cables, cooling, etc), and in turn the support structure due to the overall weight reduction.
- 3. Using light weight materials for module and support structure.** Further reduce the material budget.

# AC-LGAD TOF Detectors for EIC – eRD112

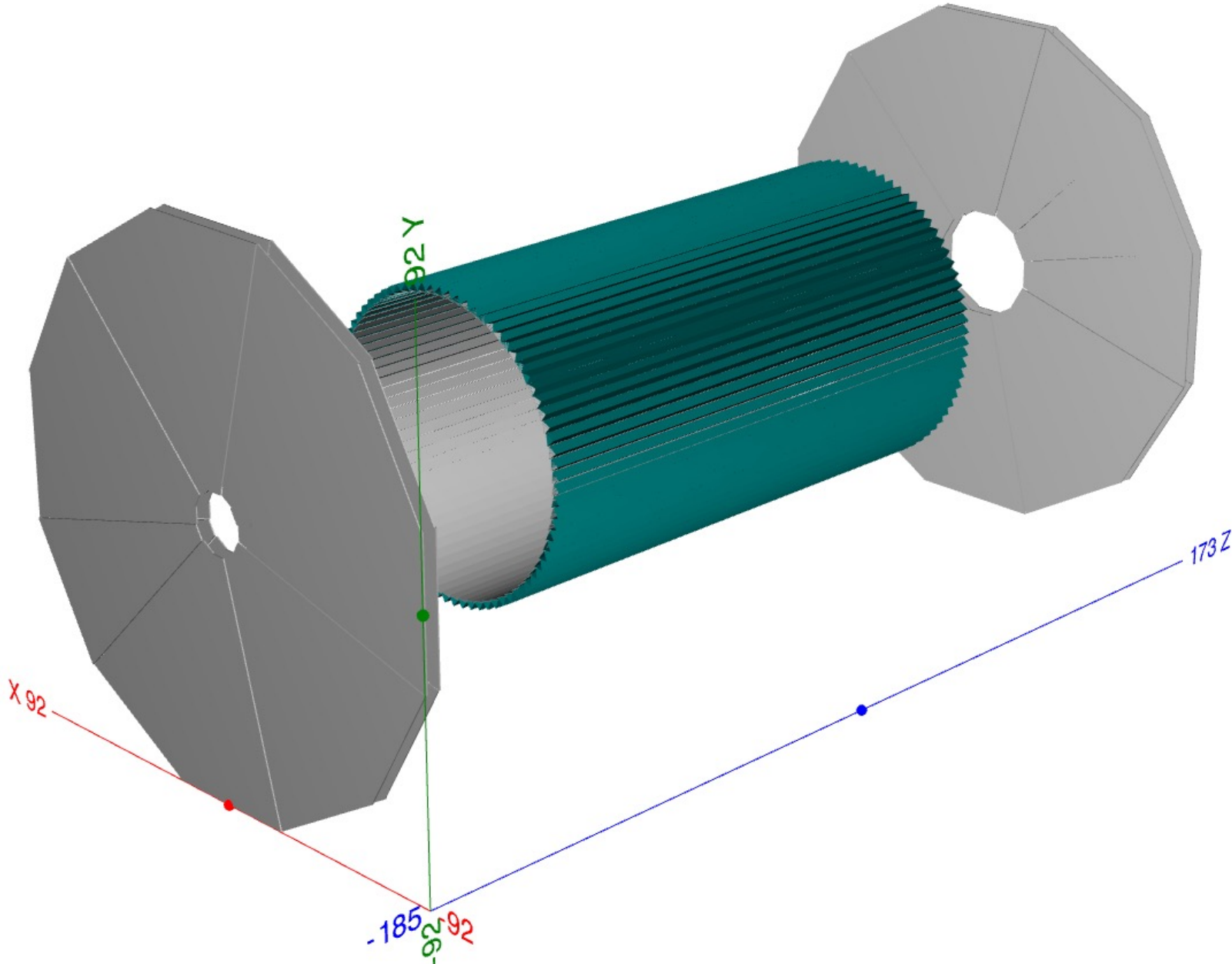

## Barrel TOF

Single layer with 30 ps resolution and 2% $X_0$  material budget per layer

## Forward TOF

Double layer with 25 ps resolution and 5% $X_0$  material budget per layer

## Backward TOF

Double layer with 25 ps resolution and 5% $X_0$  material budget per layer

## START Time

20 ps resolution

# AC-LGAD TOF Detectors in ATHENA DD4HEP

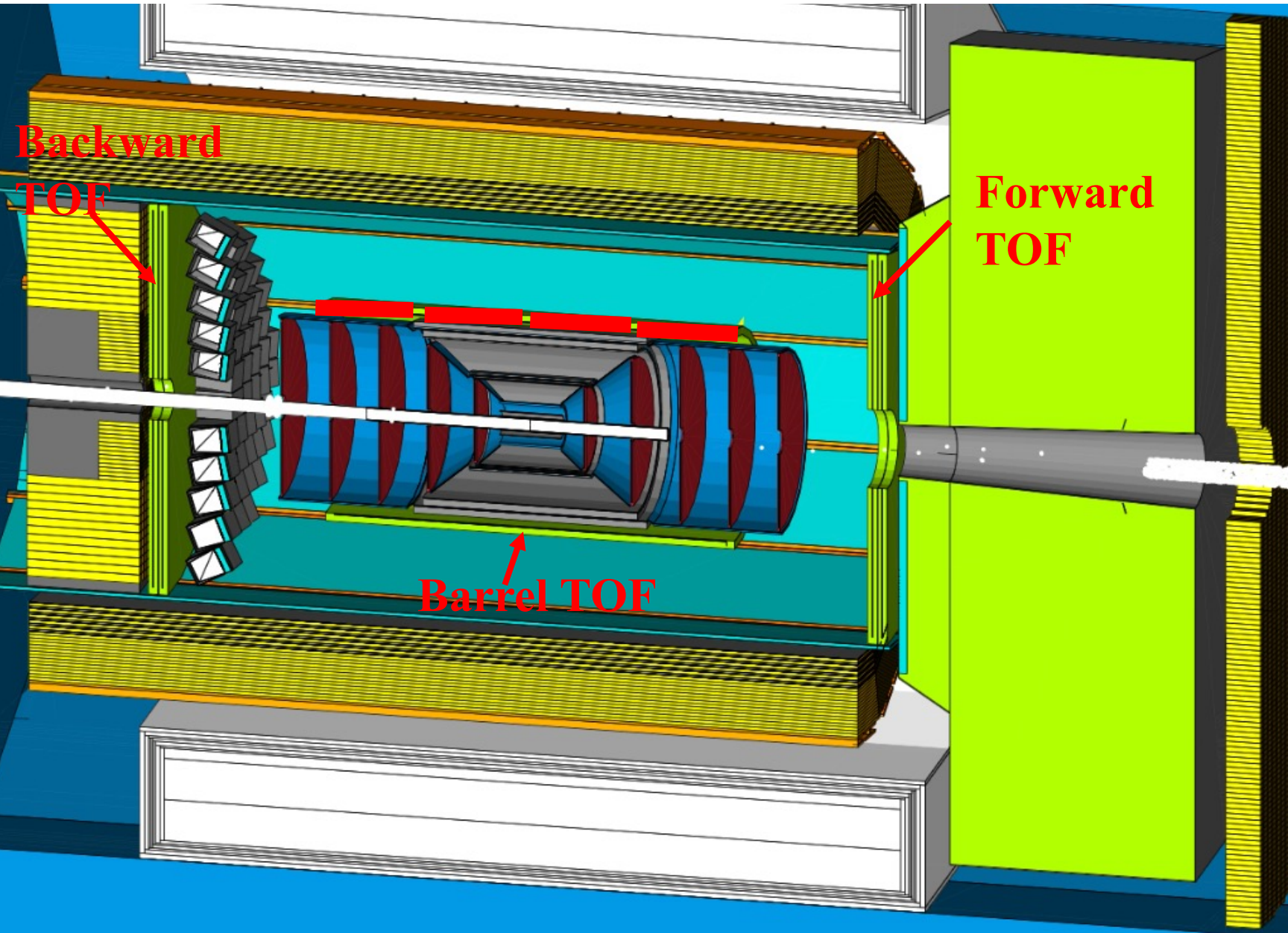

**Barrel TOF** (Area=6.28m<sup>2</sup>)  
Z=[-1m, 1m], R=0.5m,  
Eta=[-1.44, 1.44]

**Forward TOF** (Area=5.44m<sup>2</sup>)  
Z=1.73m, R<sub>in</sub>=0.19m, R<sub>out</sub>=0.95m  
Eta=[1.36, 2.91]

**Backward TOF** (Area=5.44m<sup>2</sup>)  
Z=-1.85m, R<sub>in</sub>=0.19cm, R<sub>out</sub>=0.95m,  
Eta=[-2.97,-1.42]