

EIC EPIC Tracking Detector Developments and Plan

Xuan Li (Los Alamos National Laboratory)
on behalf of the EIC EPIC Tracking Working Group

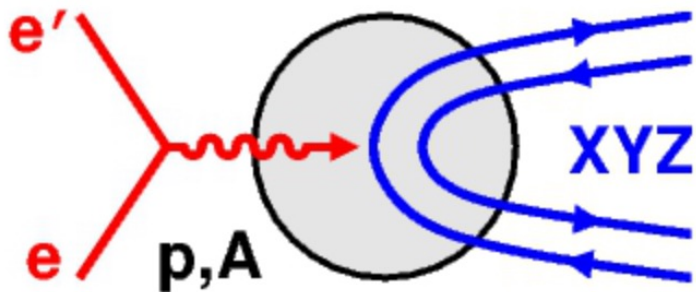

Exotic heavy meson spectroscopy and
structure with EIC

August 15-19, 2022

CFNS Center, Stony Brook University

Outline

- EIC reference tracking detector design.
- EIC EPIC tracking detector updates:
 - Goals and work status
 - Recent update highlight: detector geometry optimization and performance validation.
- Plan towards the technical report preparation

EIC tracking detector reference design

- The EIC reference tracking detector consists of integrated MAPS, MPGD (e.g., μ Rwell) and AC-LGAD tracking subsystems. Detailed detector segmentation and service parts have been implemented in the Fun4All framework.
- The tracking detector layout:
 - Barrel: 5 MAPS layers, 3 μ Rwell layers and 1 AC-LGAD layer. Inner Radius: 3.3 cm, Outer Radius: 77.0 cm.
 - Hadron endcap: 5 MAPS planes and 1 AC-LGAD plane. Minimum z: 25 cm, Maximum z: 182 cm.
 - Electron endcap: 4 MAPS planes and 1 AC-LGAD plane. Minimum z: -155.5 cm, Maximum z: -25 cm.

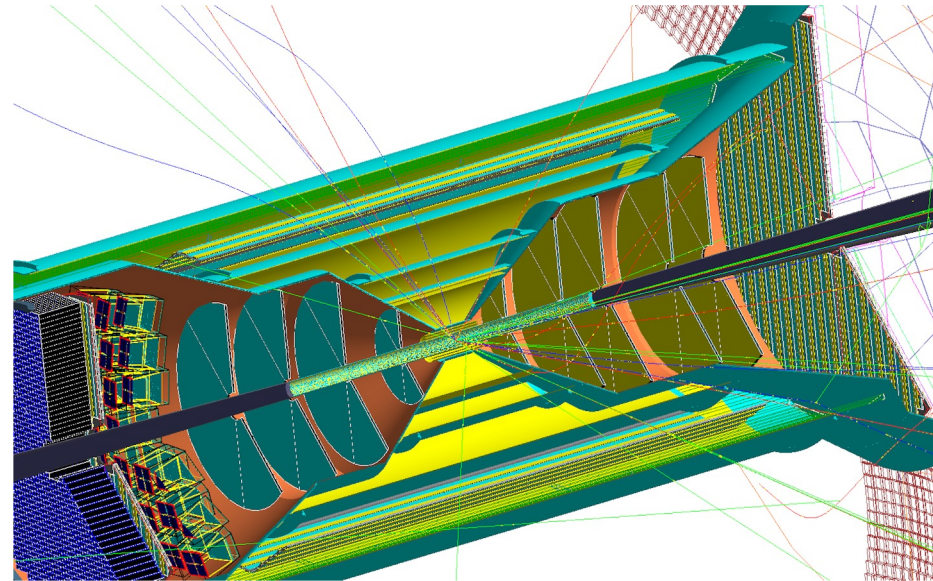

EPIC Tracking Detector Working Group Information

- Move towards the EIC detector technical design by the EPIC collaboration.
- About the EIC EPIC tracking working group:
 - Conveners: Xuan Li (xuanli@lanl.gov), Kondo Gnanvo (kagnanvo@jlab.org), Laura Gonella (laura.gonella@cern.ch), Francesco Bossu (francesco.bossu@cea.fr)
 - Email mailing list: eic-projdet-tracking-l@lists.bnl.gov
 - We have weekly meetings scheduled at 11:00AM US eastern time every Thursday and the meeting indico link: <https://indico.bnl.gov/category/404/>
 - Mattermost channel: <https://eic.cloud.mattermost.com/main/channels/tracking>
 - WIKI page: <https://wiki.bnl.gov/EPIC/index.php?title=Tracking>
- Welcome new collaborators to join us and send us your tracking performance requirements!

EPIC tracking WG work plan and goals

- Simulations:
 - Simulation task break down and priority list in <https://docs.google.com/spreadsheets/d/1Jp1-V7MavZFejn2SG185YarbMlpGCBYGfF7yz4Y-Azc/edit?usp=sharing>
- Technology review:
 - Complete review of the choice of tracking technologies.
 - Identify risks & fallback solutions for each technology.
 - Establish the timelines to CD2/3A.
 - Close coordination with the detector consortia (EIC-SC, eRD108).
- EIC Tracking Detector configuration:
 - Develop a technical design of the integrated tracking detector, which can meet the proposed EIC physics requirements.
- Validate the tracking performance based on inputs from the physics WGs:
 - List of key tracking requirements such as momentum resolution, vertex and projection spatial resolutions.

Geometry optimization and simulation studies for the silicon tracker

- **Vertex layers**

- The radii need to be adjusted around 5 mm clearance from the beam pipe are needed because of beam pipe backout and constraints from ITS sensor size

- **Tracking layers**

- The material assumed in the Reference Detector proposal is 0.05%X/X₀ per barrel layer.
- This low value cannot be achieved by the technology and needed update.
- Also, check the impact on momentum resolution by repositioning the sagitta layers.

- **Disks**

- The last disk on both side in the Reference Detector design is currently floating and not supported. Service cone needs updating to make the required support connections.

- **Hits per track as function of rapidity and p_T /momentum**

- The average number of hits per track in the electron going direction is more than 4 hits on average.
- Needs further verification in simulations with events including background.
- EIC background impact on the tracking performance needs evaluation.

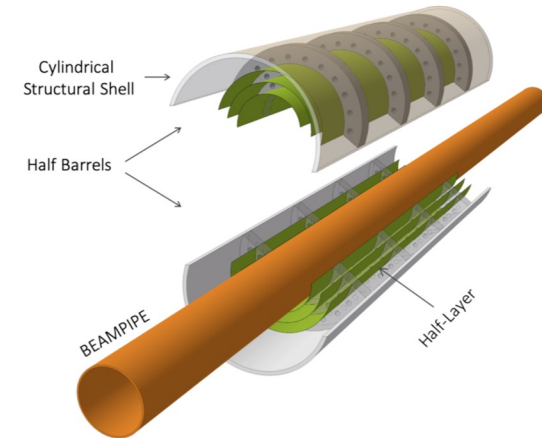

Barrel silicon vertex/tracking optimization I

- Silicon vertex optimization:

	L1/L2/L3 radii [mm]
Reference design	33/43.5/54
Reference design + offset so first layer at 5mm from beam pipe	36/46.5/57
ITS3 sensor design as is	36/48/60 → chosen
Modified ITS3 sensor size (i.e. modified stitching plan)	36/42/48

- Reference design and reference design + offset not achievable with ITS3 reticule size (i.e. basic unit that is repeated in x and y to form wafer-scale stitched sensor).
- Using the ITS3 sensor design as is gives better performance than what can be achieved by changing the stitching plan and it is cheaper as no extra design work is needed.
- **YR requirements still not met at $p_T < 6$ GeV w/ 1.5T B filed.**

Stephen Maple

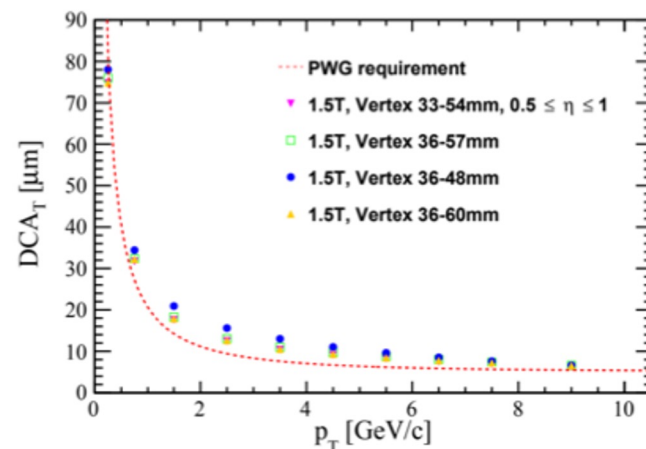
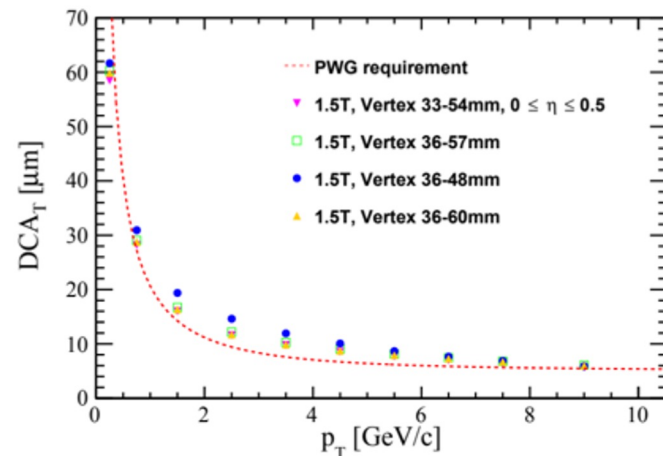

Barrel silicon vertex/tracking optimization II

• Silicon vertex and sagitta layer optimization:

Updated Silicon barrel geometry in simulation:

	r (cm)	length (cm)	X/X0
1	3.6	27	0.05%
2	4.8	27	0.05%
Support	5.7	15.4	0.1%
3	12.3	27	0.05%
Support	12.6	30.6	0.1%
4	30	77	0.25%
5	40	104	0.55%

All black numbers
are radii in units
of cm

All red numbers
are material
budgets in units
of % X0

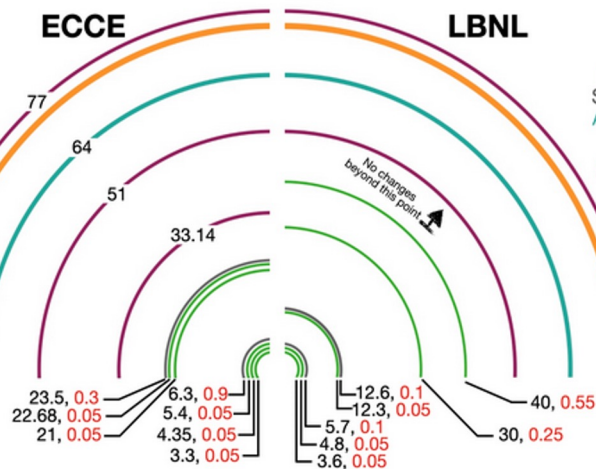

Ernst Sichtermann, Rey Torres

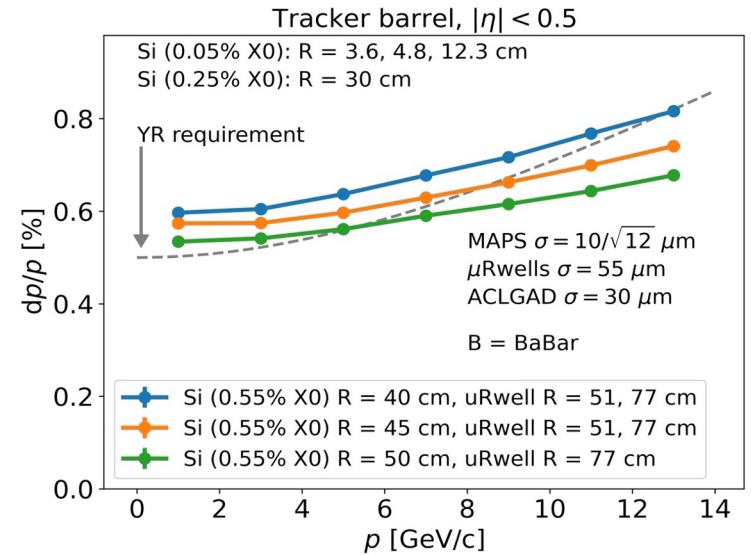

- Reconfiguration of vertex and sagitta layers position and material budgets implemented in MC.
- Moving out the 3rd vertex layer and the sagitta layers can help improve the tracking momentum resolutions to get close the EIC YR requirements.

Barrel silicon vertex/tracking optimization III

• Silicon vertex and sagitta layer optimization:

Nicolas Schmidt

Vertex layer	radius [mm]	sensors (half shell)
0	36.16	113.1x250mm
1	48.22	2 * 75.5x280mm
2	60.19	2 * 94.3x280mm
Sagitta layer	radius	sensors (half shell)
0	198.3	5 * 94.3x280mm + 2 * 75.5x280mm
1	210.3	7 * 94.3x280mm

- 3 vertex layers with 0.05% X /X0
- 2 sagitta layers with optional kapton foil **0.11% X /X0**
- radii of layers based on ITS3 sensor sizes
- all 5 layers curved

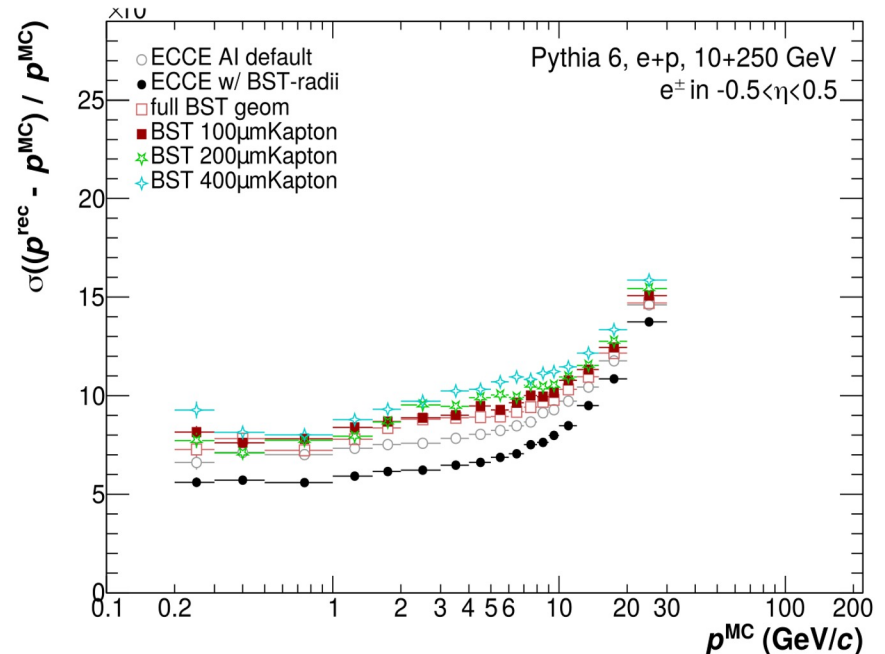
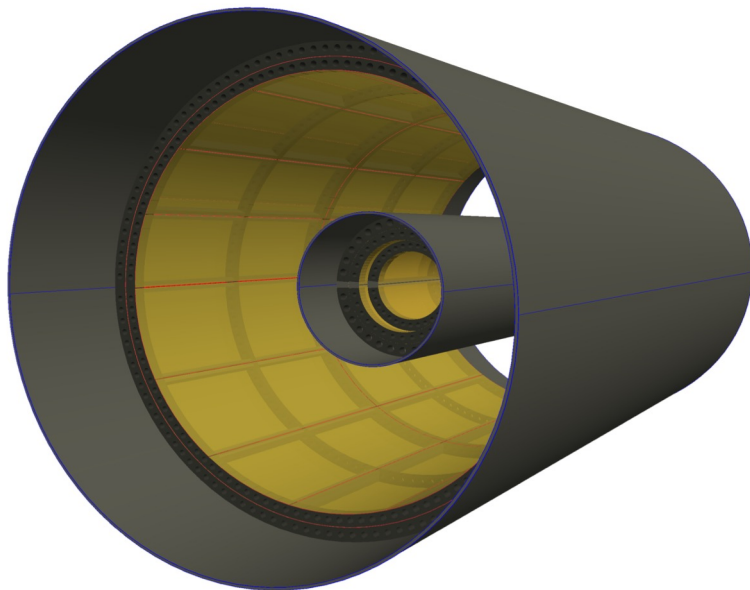

Key points of ongoing Si tracker optimization

- Two solutions explored that could recover momentum resolution once constraints from beam pipe backout, achievable sensor size and material budgets are folded in.
- Both propose 5 layers of silicon in the barrel region.
 - Note that this will need to be re-evaluated when simulations are done with events including background to understand if 5 layers are enough.
- One solution (slide 10) has been implemented in the first simulation production
 - R&D needs to achieve 0.05%/0.25% in the layers at 12.3/30 cm can be met with eRD104/111.
- The other solution (slide 11) will be carried forward under the generic R&D program.
- Optimization of the disks and adding layers/planes for redundancy is under study.

MPGD tracker geometry optimization

- Updating the reference detector
 - Redundancy vs number of hits per track
 - Synergy with the Silicon tracker
 - Addition of a MPGD layer behind the dRICH:
 - Help improving the angular resolutions
 - Technology selection (MM, μ RWELL or both): see next

• Thicknesses

- Updating Reference Detector's design: $\sim 0.3\% X_0$ not realistic
 - 0.5% – 1% X_0 for barrel layers
 - 1% – 2% X_0 for PID layers

• Resolutions

- Track angles impact the resolutions
- R&D ongoing to keep resolution $\sim 100\mu\text{m}$

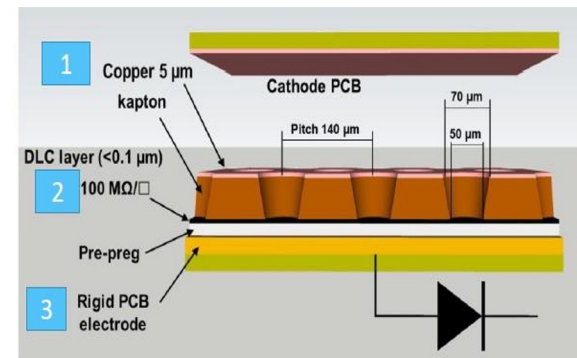

- 1 a WELL patterned kapton foil acting as amplification stage (GEM-like)
- 2 a resistive DLC layer (Diamond-Like-Carbon) for discharge suppression w/ surface resistivity $\sim 50 \div 100 \text{ M}\Omega/\square$
- 3 a standard readout PCB

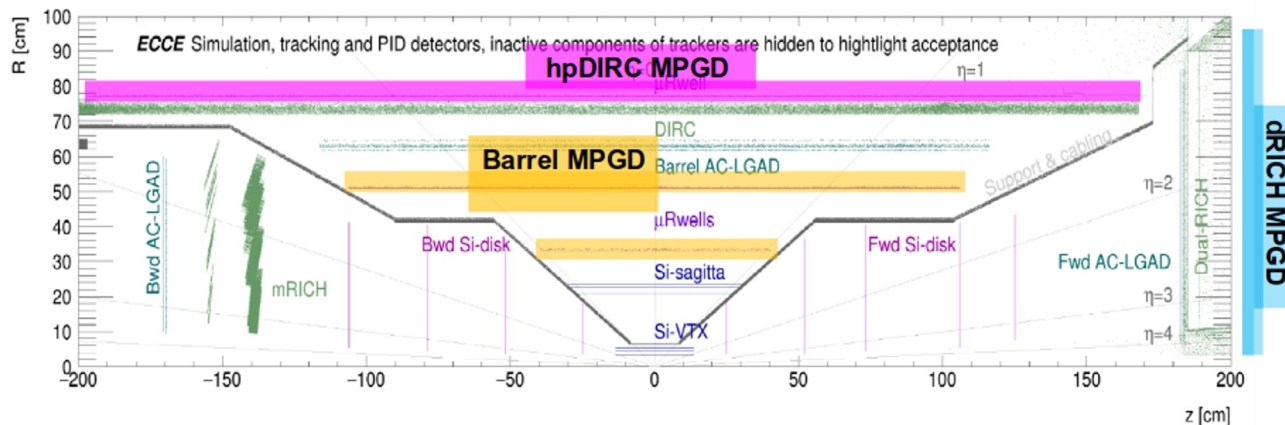

MPGD technology choices (from eRD108)

Barrel MPGDs

Requirements:

- Low mass ($<0.5\%X_0$)
- Full acceptance
- Spatial resolution $\sim 100\mu\text{m}$

Technology choice:

- Starting point: CLAS12 **cylindrical MicroMegas** (0.4% X_0 in active area)
- Ongoing R&D: 2D readout choice

Integration:

- Arrangement of cylindrical tiles with overlaps
- Preliminary concept of support and services developed

Fallback solution:

- Cylindrical μRWELL : ongoing R&D

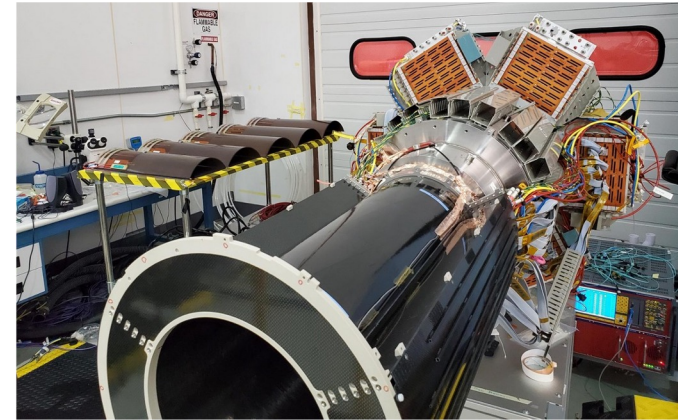

Preliminary design of micromegas tracker for ATHENA proposal

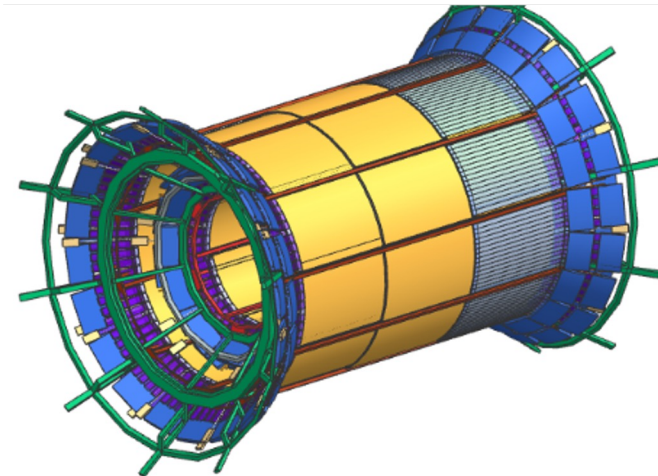

MPGD technology choices (from eRD108)

Planar MPGD trackers:

- Tiles behind the hpDIRC
- A layer behind the dRICH

Requirements:

- Space limitations
 - About 2cm thick boxes integrated in the hpDIRC structure
- Spatial resolutions: 50–100 μm
- No strict requirements on material budget: 1%--2%X₀

Technology choice:

- **Planar μRWELL**
- Ongoing R&D for large area detectors and 2D readout

Integration:

- Tight spaces and interference with PID detectors
- Discussions will start soon

Fallback solutions:

- hpDIRC: MicroMegas
- dRICH: GEM or MicroMegas

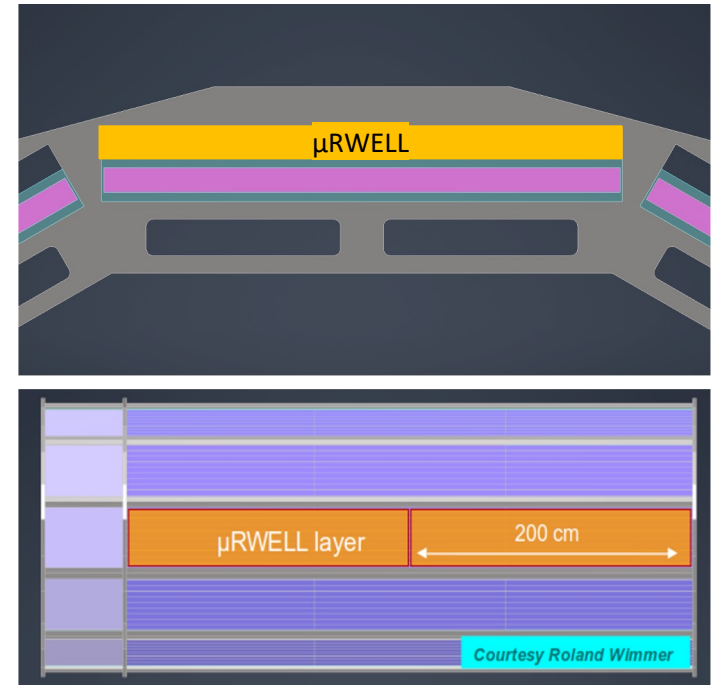

μRWELL layer behind dRICH

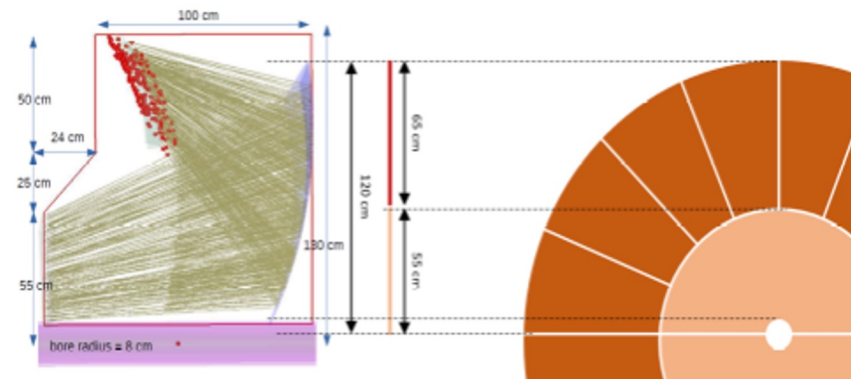

EPIC tracking WG remaining tasks and requests

- **Simulation developments**
 - Will migrate to the EPIC common software framework.
 - Will re-evaluate the tracking performance with the new 1.7T B-field.
 - Background implementation for tracking performance studies.
 - Further optimization in the endcap disks, detector redundancy studies.
 - Alternative technology geometry to be included in the simulation production.
- **Technology readiness**
 - R&D plan, status and results
 - Cost, risk and schedule updates
- **Detector integration**
 - Joint studies for the detector geometry optimization and technology down selection, for example, PID and tracking requirements.
- **Physics WG inputs**

Tracking requirements for the exotic studies

- Any exotic physics requirements for the EPIC tracking subsystem?
 - Low momentum reach?
 - Tracking performance in specific pseudorapidity regions?
 - Any material budget limitation for the tracking detector to keep certain exotic measurements?
 - Detector optimization and integration?
- Any suggestions and requests?

Summary and Outlook

- The EPIC tracking working group has been formed and focuses on the tracking detector geometry optimization, updates and implement of technical details towards the pre-CDR submission are ongoing.
- The charge, plan and path forward have been defined for the EIC EPIC tracking detector related studies.
- Good progresses have been achieved for both silicon and gas tracking geometry optimization.
- We welcome your inputs and feedback for the EPIC tracking developments.

Outlook

EIC reference silicon vertex/tracking detector geometry

- The ECCE tracking detector geometries have been archived in the Fun4All ECCE associated repositories.

Barrel index	R (cm)	z_{\min} (cm)	z_{\max} (cm)
1	3.3	-13.5	13.5
2	4.35	-13.5	13.5
3	5.4	-13.5	13.5
4	21.0	-27	27
5	22.68	-30	30

H-endcap index	z (cm)	r_{in} (cm)	r_{out} (cm)
1	25	3.5	18.5
2	49	3.5	36.5
3	73	4.5	40.5
4	106	5.5	41.5
5	125	7.5	43.5

e-endcap index	z (cm)	r_{in} (cm)	r_{out} (cm)
1	-25	3.5	18.5
2	-52	3.5	36.5
3	-79	4.5	40.5
4	-106	5.5	41.5

EIC reference detector material budget scan

- From the Fun4All simulation, material budget scan of the EIC reference detector subsystems.

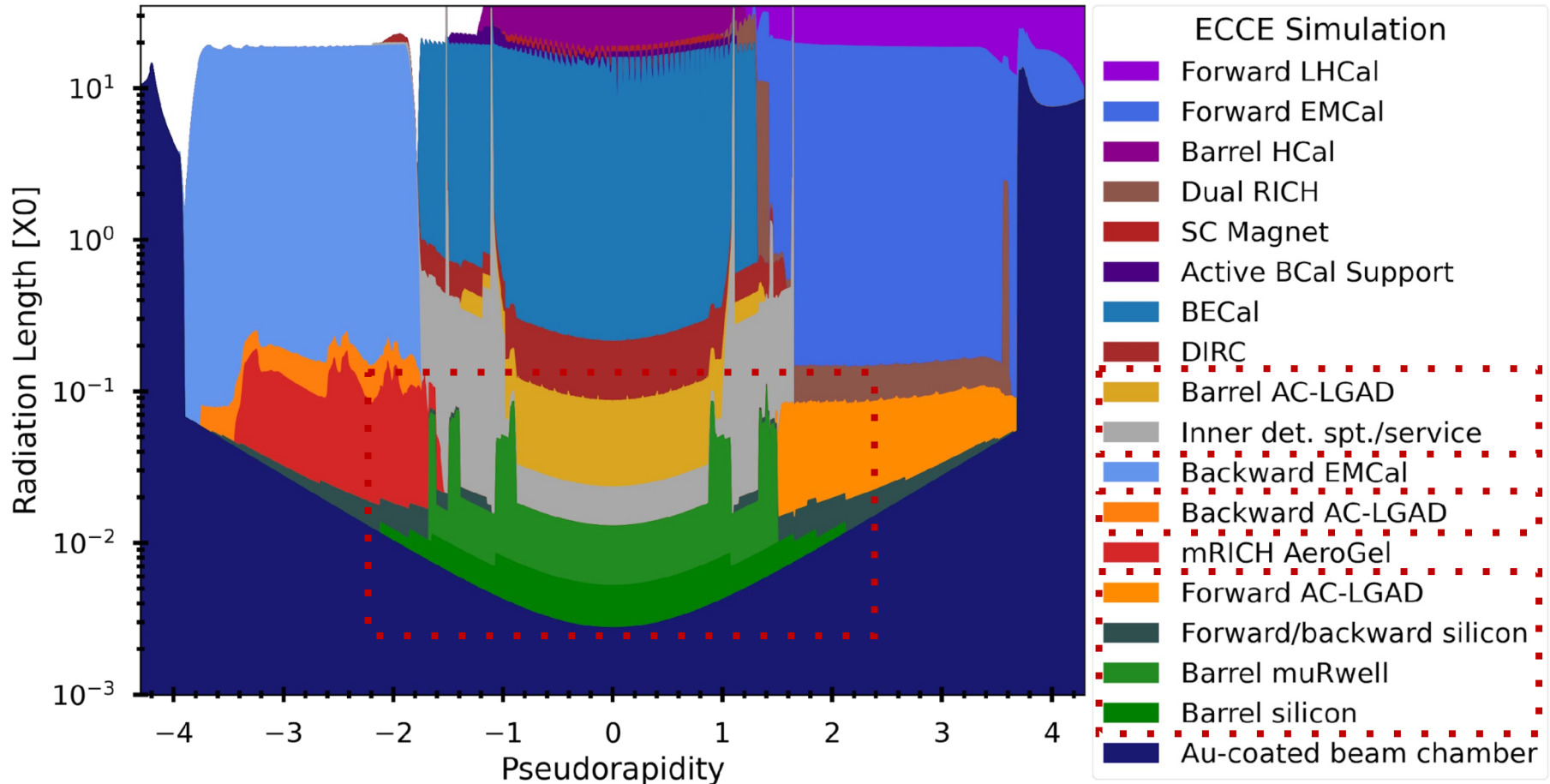

EIC reference tracking detector momentum resolution

- Track momentum dependent momentum resolution.

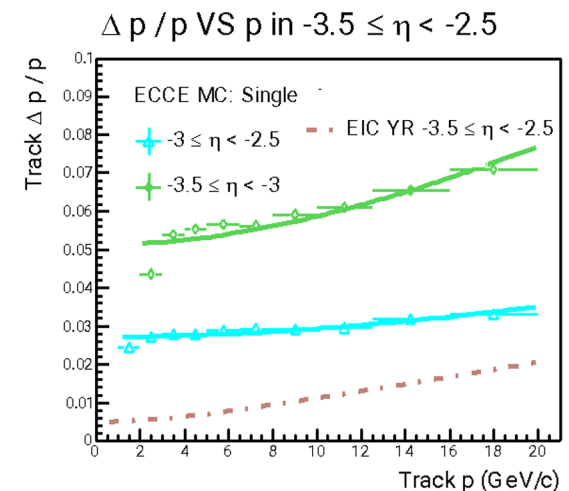
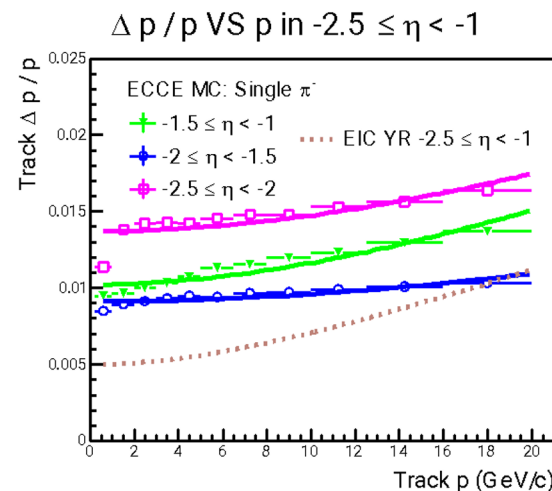
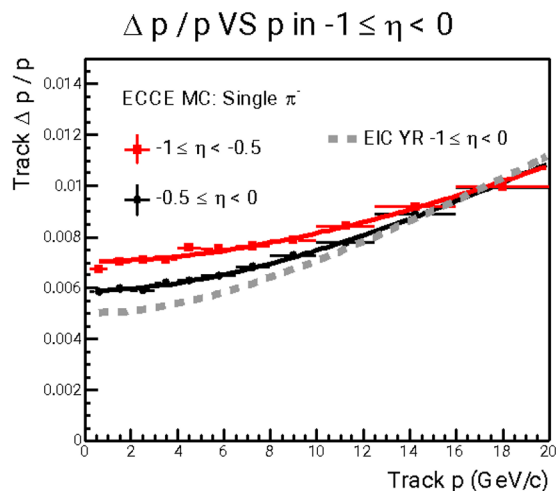
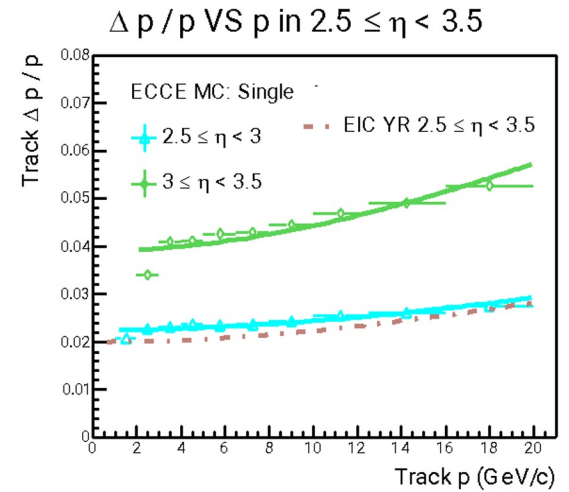
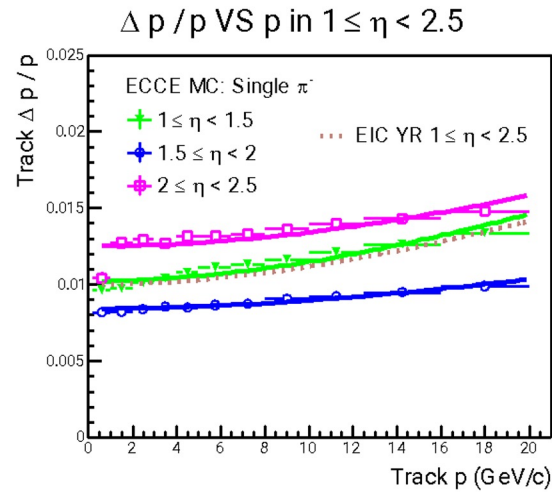
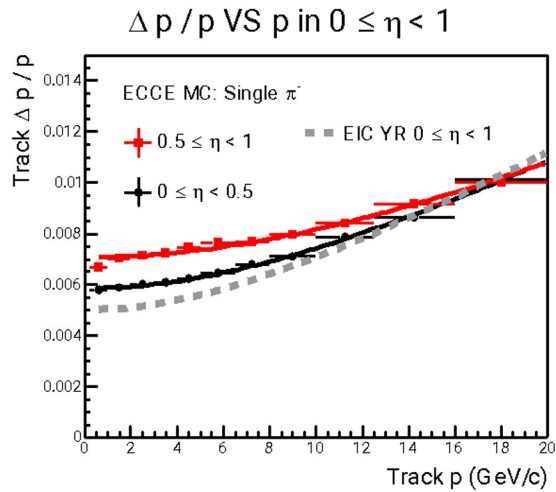

EIC reference tracking detector DCA_{2D} resolution

- Track p_T dependent DCA_{2D} resolution.

DCA_{2D} resolution VS p_T in $0 \leq \eta < 1$

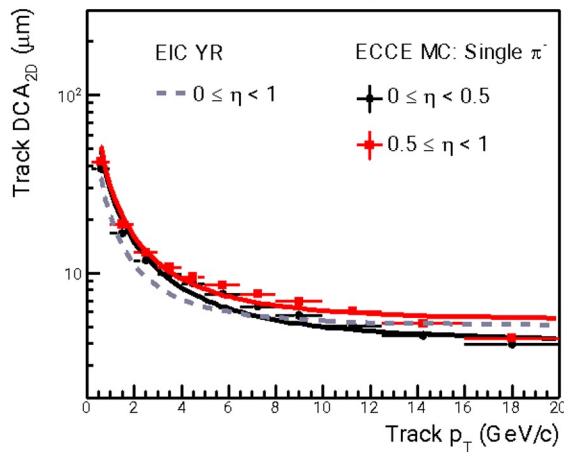

DCA_{2D} resolution VS p_T in $1 \leq \eta < 2.5$

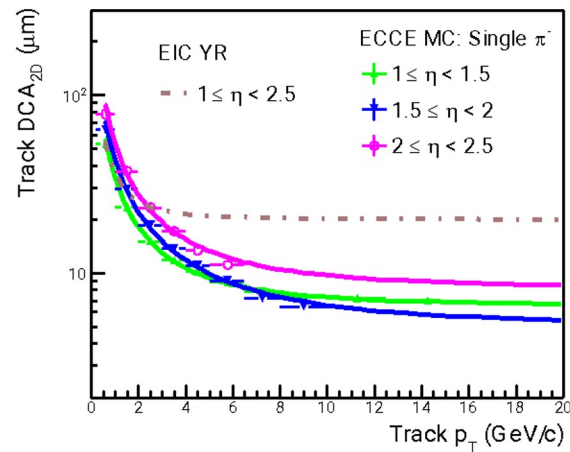

DCA_{2D} resolution VS p_T in $2.5 \leq \eta < 3.5$

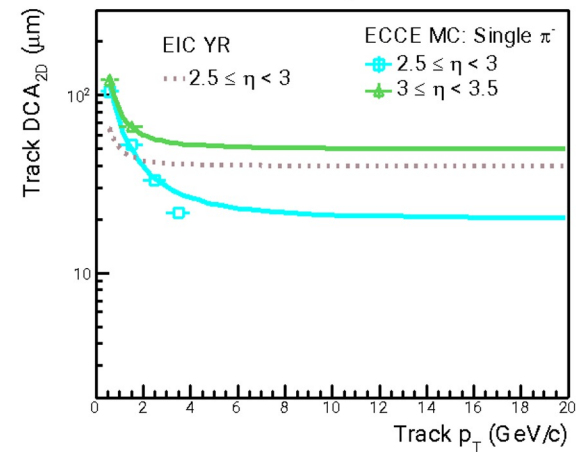

DCA_{2D} resolution VS p_T in $-1 \leq \eta < 0$

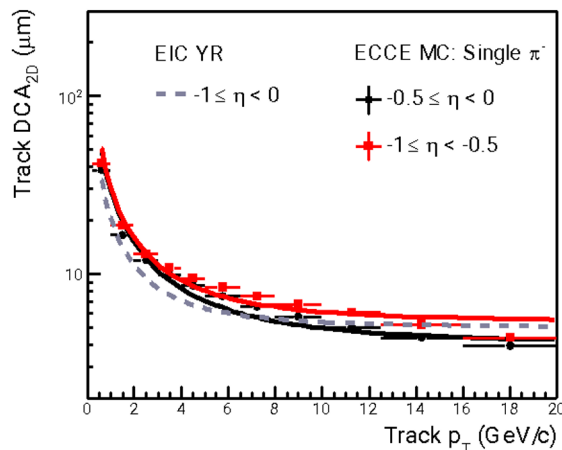

DCA_{2D} resolution VS p_T in $-2.5 \leq \eta < -1$

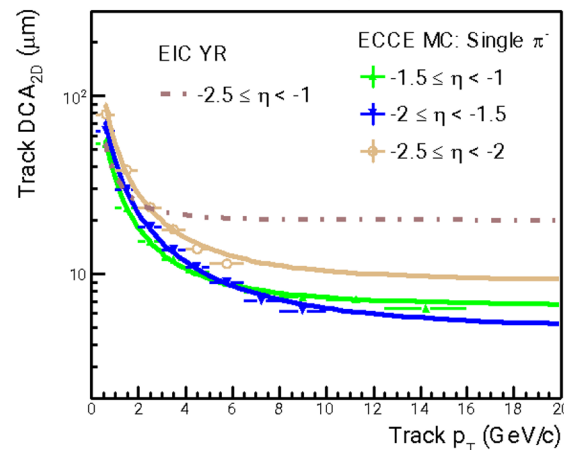

DCA_{2D} resolution VS p_T in $-3.5 \leq \eta < -2.5$

