

# 260-L LAr System Progress Report

Yichen, Sergey, Steve

10/4/22



# Lab Safety and Space Management

- COVID level in Suffolk County is MEDIUM now
- Face masks are optional onsite at BNL
- CRP coldbox ESR is still under review
- The request of pressure relief devices was approved by the safety
- ESR will be updated accordingly showing the change
- Heating in the highbay is not working, indoor temperature is only ~60F

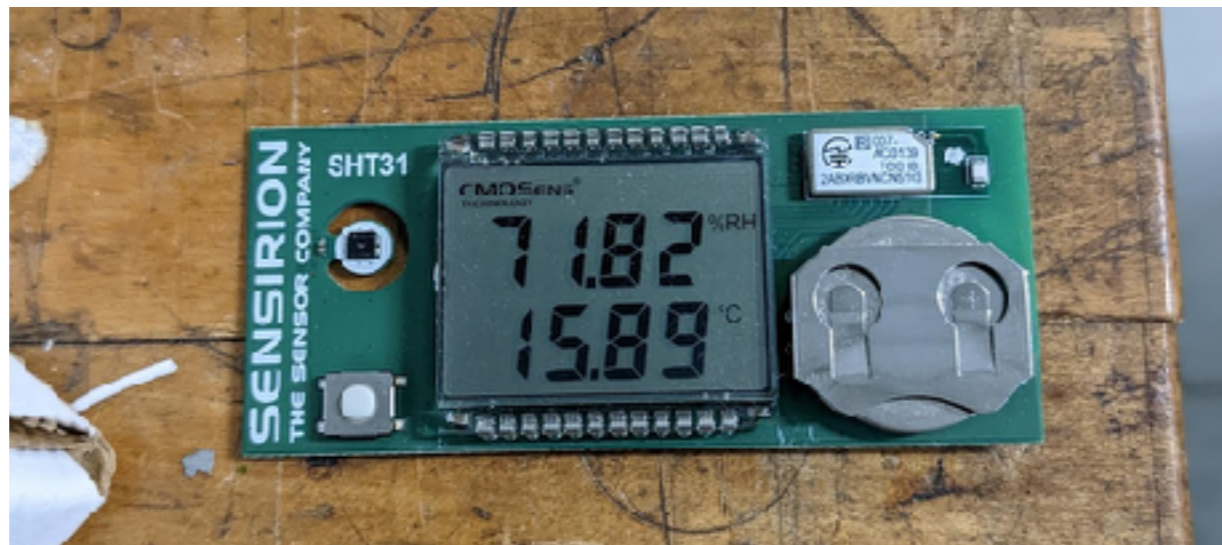

# Inline Filter Modifications

- ▶ **Safety approval received from Mike Gaffney for the pressure relief devices modifications**
  - The on-cylinder 50 psig relief valve can be replaced with a 55 psig burst disk+ 50 psig relief valve in series, vent needs to be facing downward to avoid blowing to the face
  - The 50 psig relief valve on the liquid fill line can be replaced with a 100 psig burst disk
  - ESR and diagram needs to be updated accordingly
  - Replacement of the parts can be conducted with positive gas flow
  - The inline filter flipping in progress
  - All Insulations are removed for the flipping

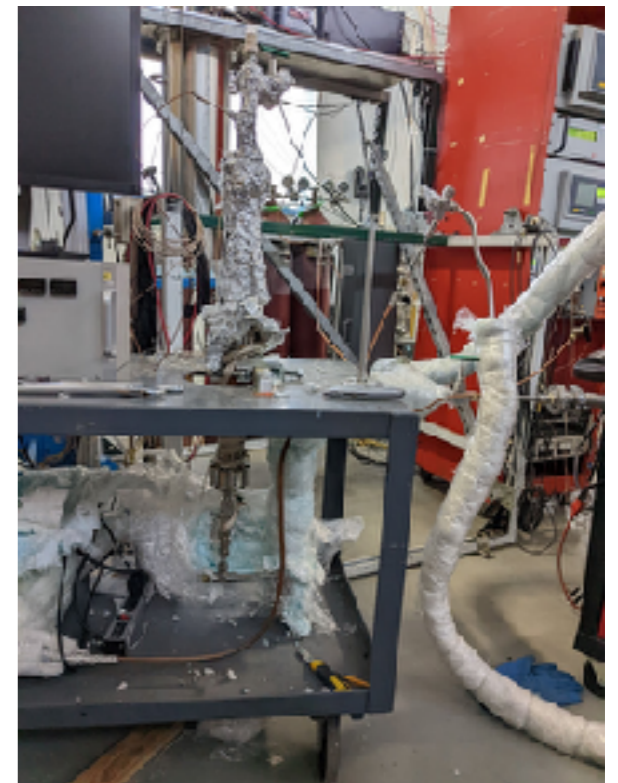

# LAr Heater Test

## ► Tried our LAr heater in LN2

- Full power of the heater: 735W
  - Running with 1/4 power for ~5 mins
  - Running with 1/2 power for ~5 mins
  - Running with full power at 110V AC, for ~ 15mins
  - Then, Heater parts broke
- Need to find a sustainable solution for LAr heater



# O2 Analyzer reading calibration

- ▶ **O2 pressure vs. reading calibration with GAr directly supply from LAr dewar**
  - We have observed strong correlation between the inlet pressure and [O2] readings on the O2 analyzer
  - Pressure reading from the gas regulator, range 2-23 psig, 1 psi interval
  - Each pressure point, the measurement lasted 15-30 mins until the reading stabilized

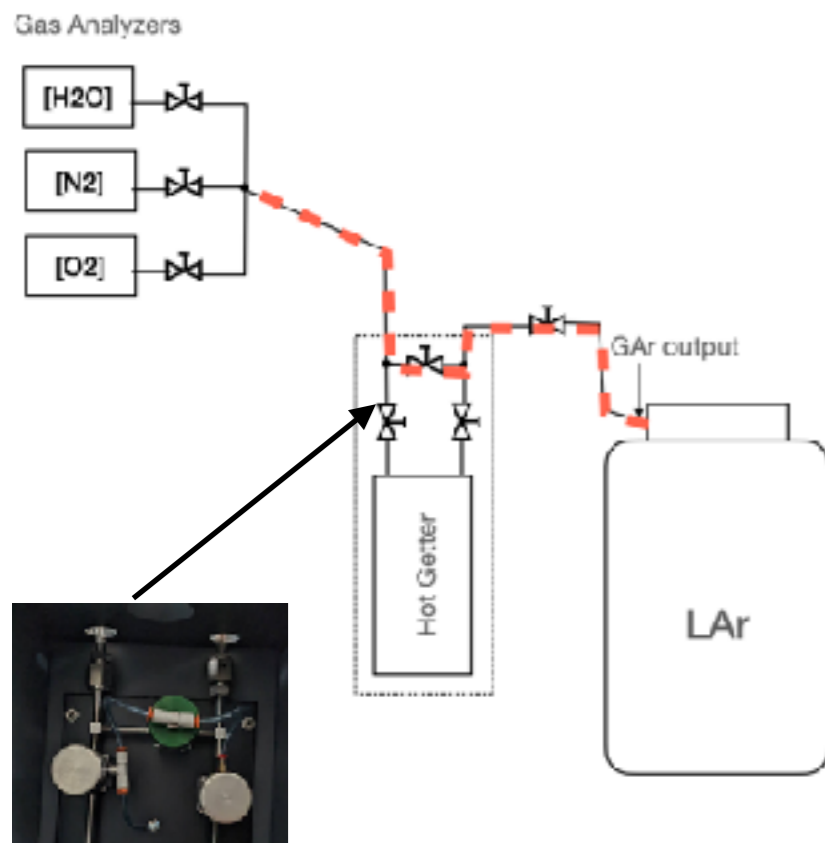
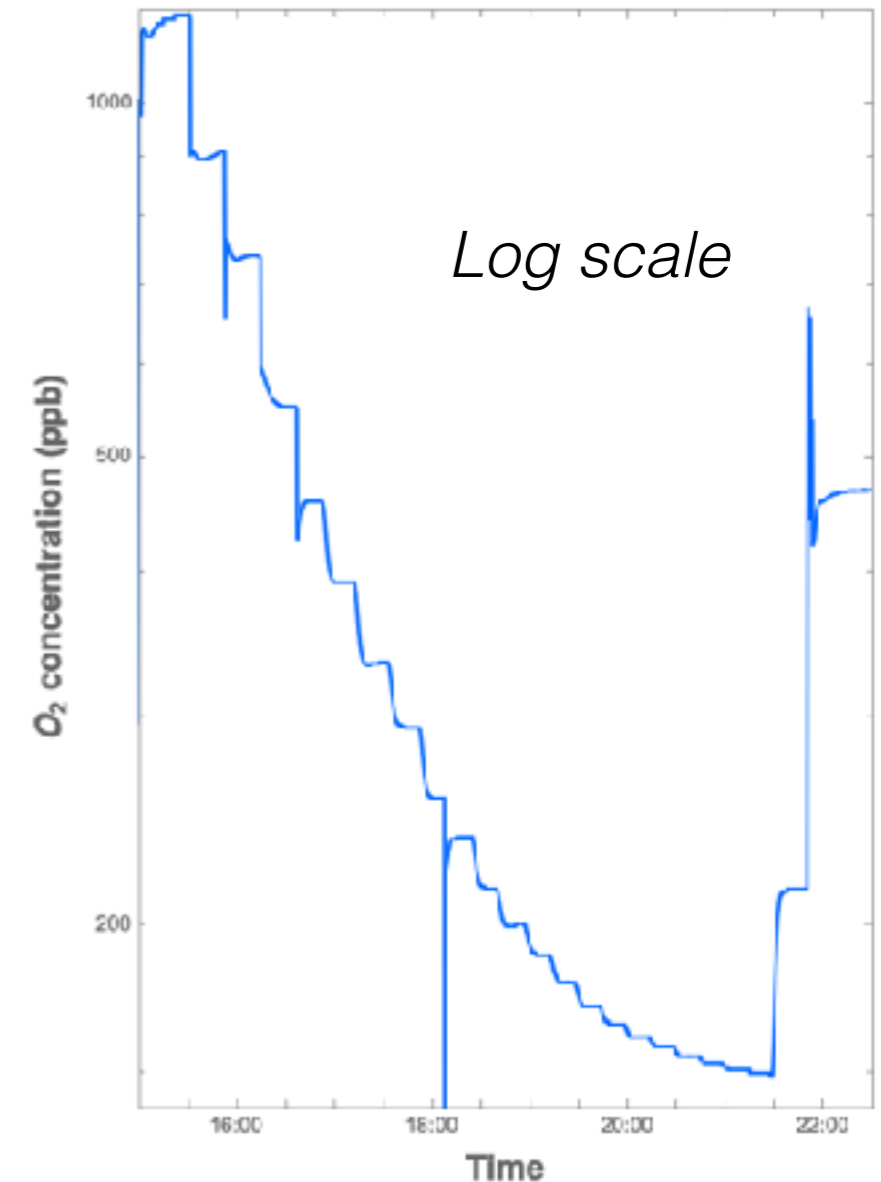
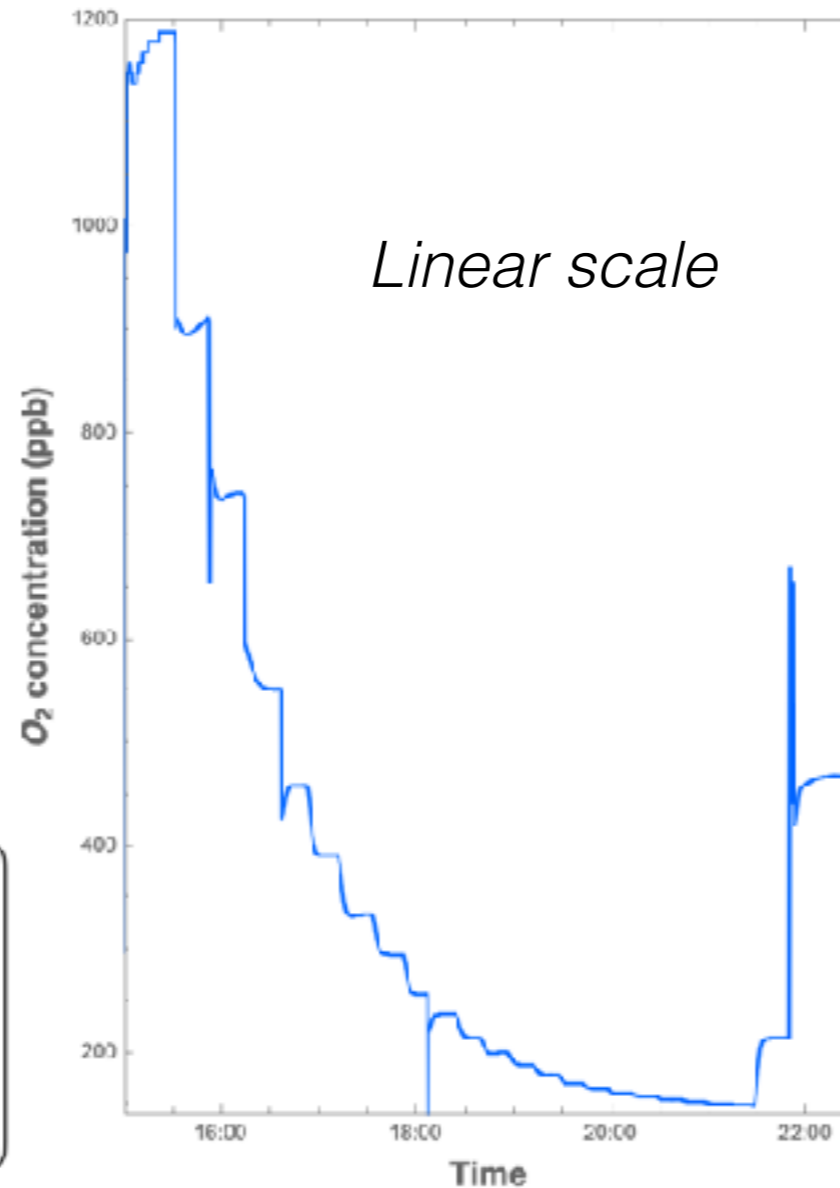
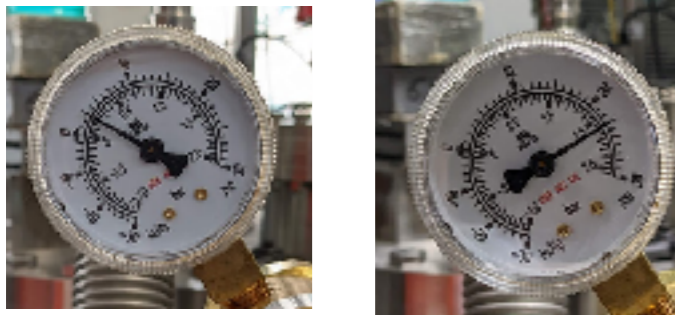

# O2 Analyzer reading calibration

- ▶ **O2 pressure vs. reading calibration with GAr directly supply from LAr dewar**
  - Nominal inlet pressure according to the manual is 15-25 psig, [O2]~150 ppb in the range
  - Pressure points of 6 psig and 12 psig repeated at the end
  - The [O2] reading is reproducible at the same pressure
  - We can establish a calibration between the inlet pressure to the actual concentration
    - Large correction needed to the analyzer reading for our system working at low pressure range
    - Need to repeat the calibration with different purity levels

