



# MAGNETIC SOLUTION AND ASSEMBLY DEVELOPMENT BY RARE EARTH MAGNET PRODUCER

September 14, 2023

Heeju Choi  
Electron Energy Corporation  
924 Links Avenue, Landisville, PA 17538, USA  
[www.electronenergy.com](http://www.electronenergy.com)

**2023 Workshop on  
Fixed Field Alternating Gradient Accelerators (FFA'23)**

Hosted by Thomas Jefferson National Accelerator Facility  
September 10–15, 2023

- 1. EEC Introduction**
- 2. Rare Earth Magnets**
- 3. Beam Focusing Magnets**
  - 1) Traveling Wave Tube
  - 2) Klystron
  - 3) Accelerator
  - 4) Adjustable Quadrupole
  - 5) Adjustable Phase Shifter
- 4. PM Replacing EM Examples**

**Headquarter**



**Post-sintering Operations**



# EEC Introduction



EEC is founded in 1970 (in a Milk House with 2 employees) as Marlin Walmer pioneered the processing and subsequent commercialization of an entirely new class of permanent magnets (SmCo)



40,000 square foot facility was built to support the steady growth of business from 1970-1985



Add a new 45,000 square foot facility now housing the magnet finishing operation



EEC electron energy corporation  
**50**  
since 1970

EEC received 25th SBIRs & STTRs awards since 1996 from NASA, DOE, NSF, EPA, and DOD

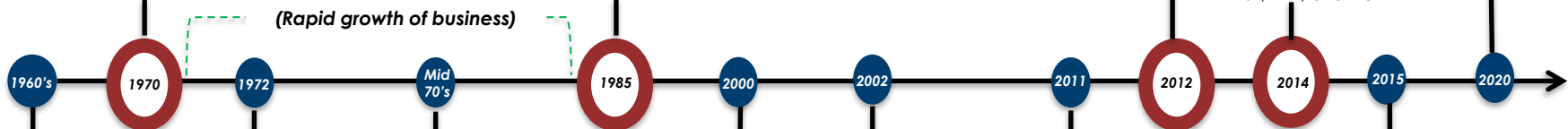

1960's  
Founder Marlin Walmer is working at Hamilton Watch pioneering platinum-cobalt magnets for the world's first electric watches

1970  
1972  
Moved to 10,000 square foot facility on Main St. Landisville

Mid 70's  
1985  
Developed Temperature Compensated SmCo that have near-zero change in magnetic field over temperature changes

2000  
2002  
Patented Ultra-High Temp SmCo 2:17 magnets in 2002 which operate at temperatures up to 550°C

2011  
2012  
EEC "Milk House" is recognized as an ASM Historical Landmark

2014  
2015  
2020  
EEC invests in additional equipment to meet increasing demand



Hamilton Watch's 1<sup>st</sup> electric watch named the "Ventura"...made famous by Elvis Presley.

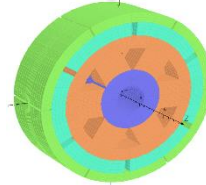

Magnetic design service



New plant layout to optimize floorplan and Equipment

## Full Service Provider of Engineered Products

### Engineering Services



Research & Development

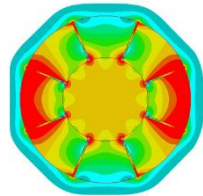

FEA modeling



Applications engineering

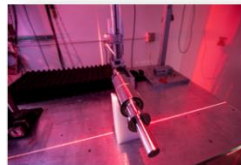

Prototyping

*Developing solutions with customers*

### Permanent Magnet Materials



Samarium Cobalt



Neodymium Iron Boron



Alnico



Dielectric materials

*Rapid in-house material customization*

### Assemblies



Rotors



Magnetic couplers



Sensors



Separators

*Scalable operations*

# EEC's Core Business

## Customer's trust EEC's magnetic experts with their "Mission Critical Solutions"



### AEROSPACE & DEFENSE



- *Missiles*
- *Satellites*



### IMPLANTIBLE MEDICAL DEVICES



- *Heart pumps*
- *Surgical tools*



### NUCLEAR



- *Control Rods*
- *Motion control*



### MEDICAL EQUIPMENT



- *Motors*
- *Sensors*

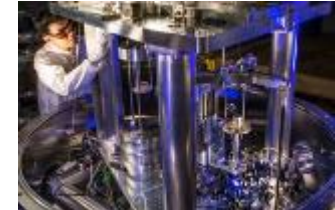

### SPECIALTY



- *Watt Balance*
- *Beam focusing*

# Markets & Customers

	<b>Communication</b>	<b>Raytheon</b>				
	<b>Motion &amp; Sensor</b>	<b>MOOG</b>				
	<b>Defense</b>			<b>THALES</b>		
	<b>Medical</b>	<b>stryker</b>				
	<b>Aerospace</b>					
	<b>Instrumentation</b>	<b>Schlumberger</b>				



## ROTOR CAPABILITIES

Combined 50+30 years of experienced producing precision rotors for a variety of markets and applications

- Balanced rotors for high speed motors
- Large rotor assemblies
- Carbon retention sleeved rotors
- Metallic sleeved rotors

**IPM Rotors**  
(Interior Permanent Magnet)



**SPM Rotors**  
(Surface Permanent Magnet)



**Magnet Production**



**Shaft Machining**



**Sleeve Machining**



**Carbon retention sleeves**



**Balancing & Final Assembly**

## STATOR CAPABILITIES

Supplier of various stators prototypes, designs, and alpha-beta prototyping and testing.

- Distributed windings
- Concentrated windings
- Slotless windings
- Segmented stator windings
- Custom windings

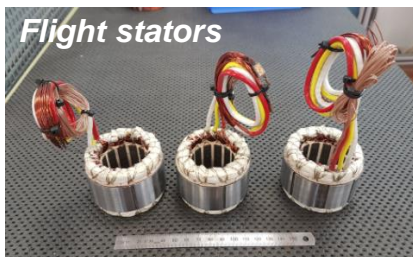

**Flight stators**



**Marine stator**



**Lamination stacks**



**Bonded core assembly**



**Coil winding**



**Slot liners**



**Installing coils**

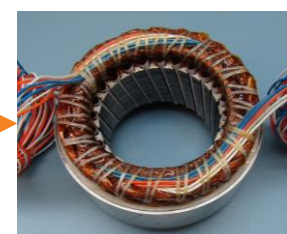

**Final assembly**  
(lacing, impregnation, & testing)



# Rare Earth Magnets



# Rare Earth Magnet Supply Chain Steps

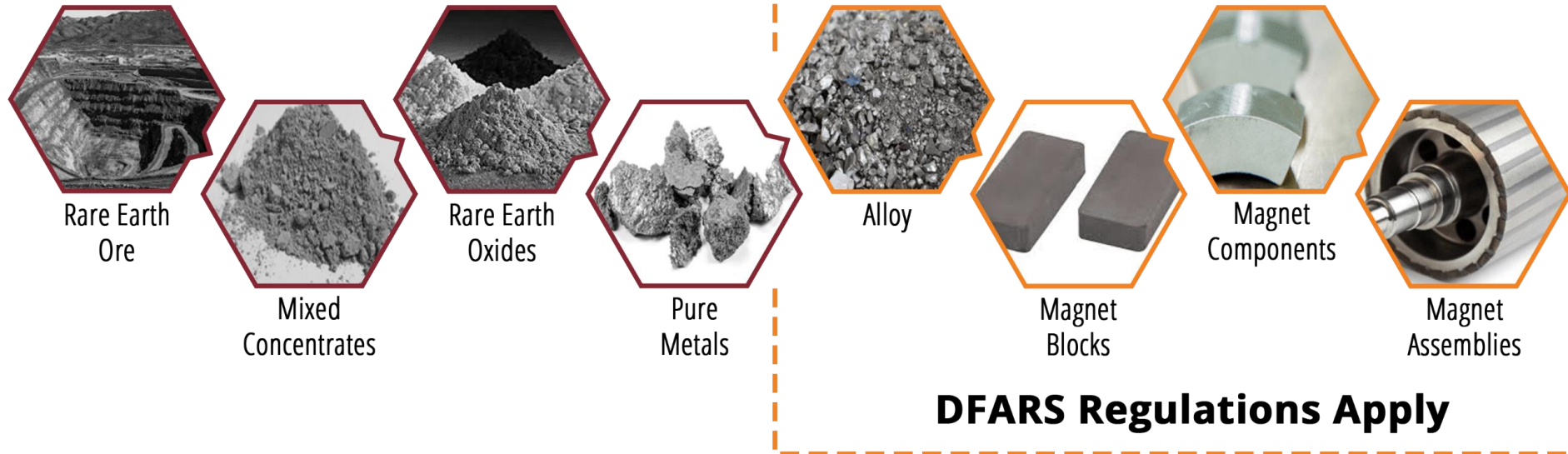

# Typical Sintered Sm-Co Magnet Production

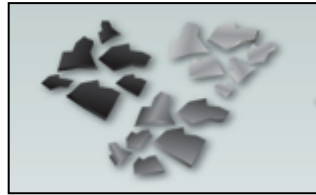

## Raw Material

EEC purchases pure raw materials-Sm,Co,Fe,Cu,&Zr for the in-house production of SmCo 1:5 & 2:17 alloys



## Induction Melting

Pure metals are alloyed in an inert gas using an induction melting furnace. Precise control of alloy chemistry allows EEC to produce a wide range of materials to meet your demanding requirements.

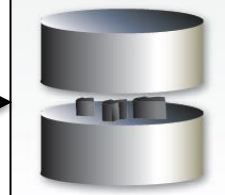

## Crushing

Using a crushing process, rare earth alloys (inter-metallic compounds) are reduced in particle size to  $\approx 250$  microns

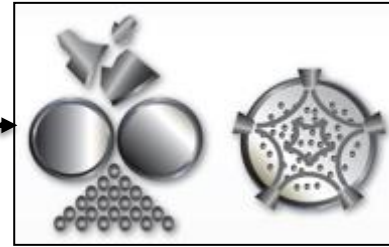

## Ball or Jet Milling

We process crushed alloy by milling and reducing to a particle size of  $\approx 3$  microns. Because the resulting fine powder is chemically reactive and pyrophoric in nature, it requires protection from air (oxygen) using inert gas.

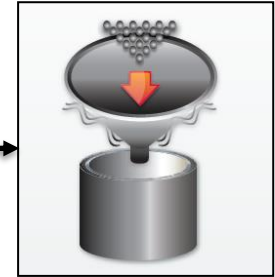

## Blending

Our ability to precisely control material compositions during the blending operation helps us achieve specific magnetic properties.

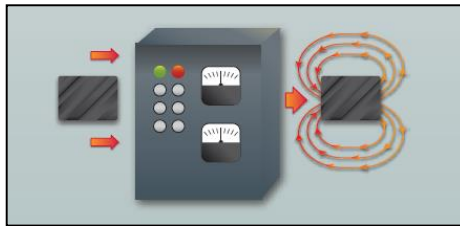

## Magnetizing, Testing, & Quality Assurance

Magnetization, stabilization and testing of rare earth magnets are done to satisfy your specific requirements.

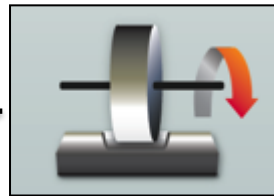

## Machining

Sintered rare earth magnets, because of their brittle nature, are machined to final dimensions using grinding, slicing, or wire EDM technology.

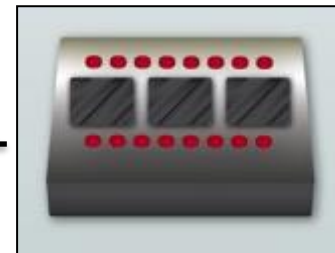

## Sinter

Densification and the development of magnetic properties are accomplished through sinter, solution and aging processes in the presence of a vacuum or an inert gas.



## Axial, Transverse & Isostatic Pressing

Axial pressing force is parallel to alignment created by magnetic field. Transverse pressing force is perpendicular to magnetic alignment field. Isostatic pressing provides equal pressure from all directions for pre-aligned powder.

# Magnet Types

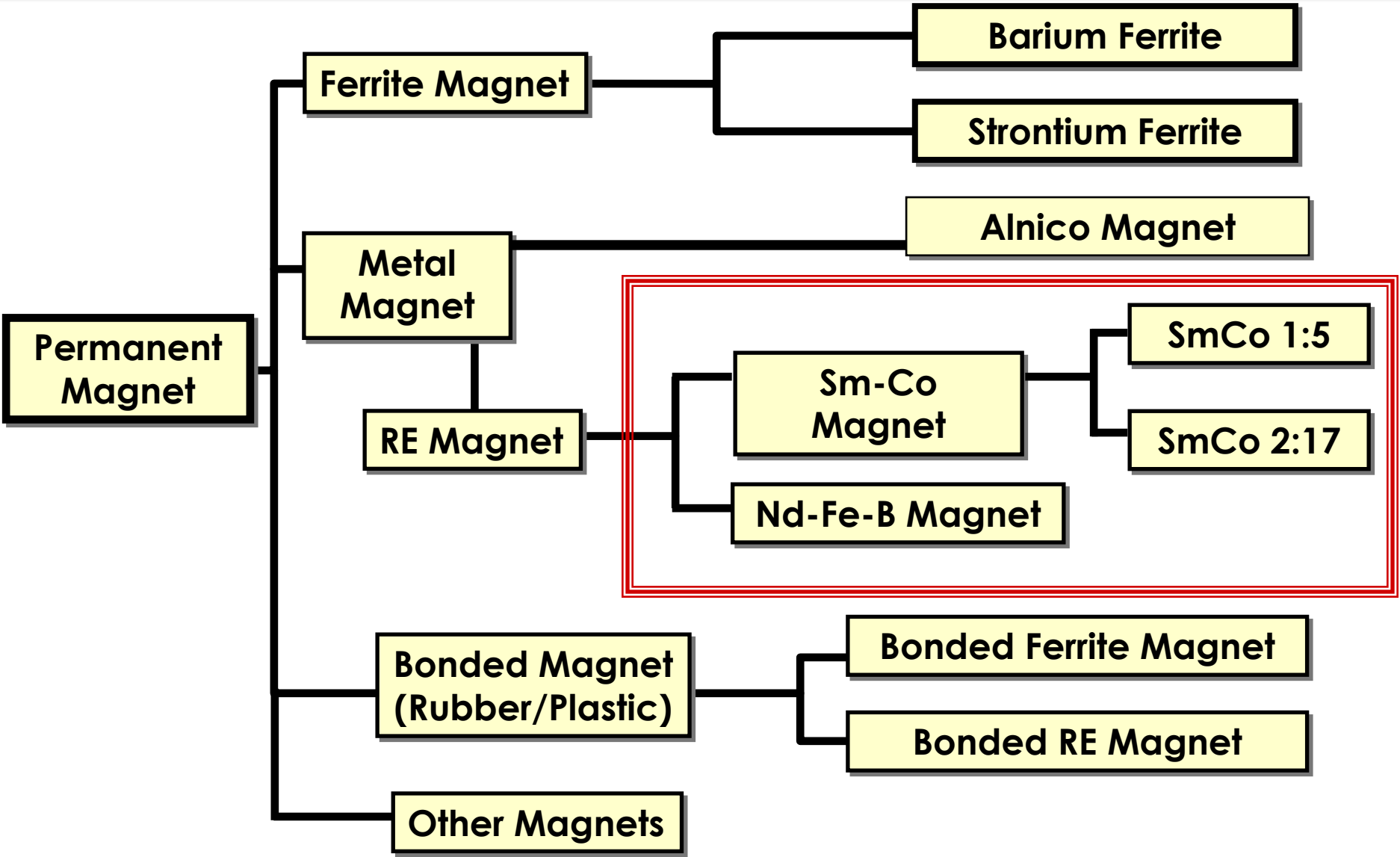



# Magnets vs. Temperature

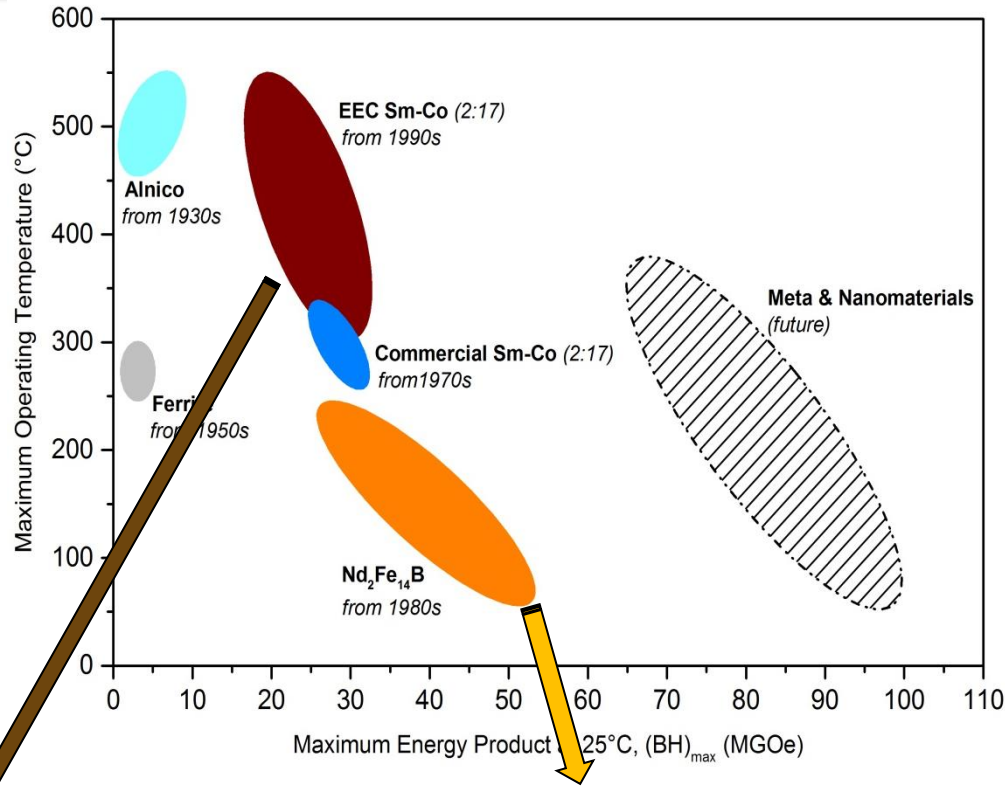

## Sm-Co magnets

- Highest  $(BH)_{max}$  available up to 34 MGOe
- Corrosion resistance is excellent; no surface coating required
- Maximum operating temperature: 550°C
- Superior thermal stability

## Nd-Fe-B magnets

- Highest  $(BH)_{max}$  available up to 52 MGOe
- Corrosion resistance is low; surface coating is needed.
- Maximum operating temperature, ~180°C for most grades, is relatively low compared to SmCo magnets (>300°C).

# Magnets vs. Cryogenic Temperature

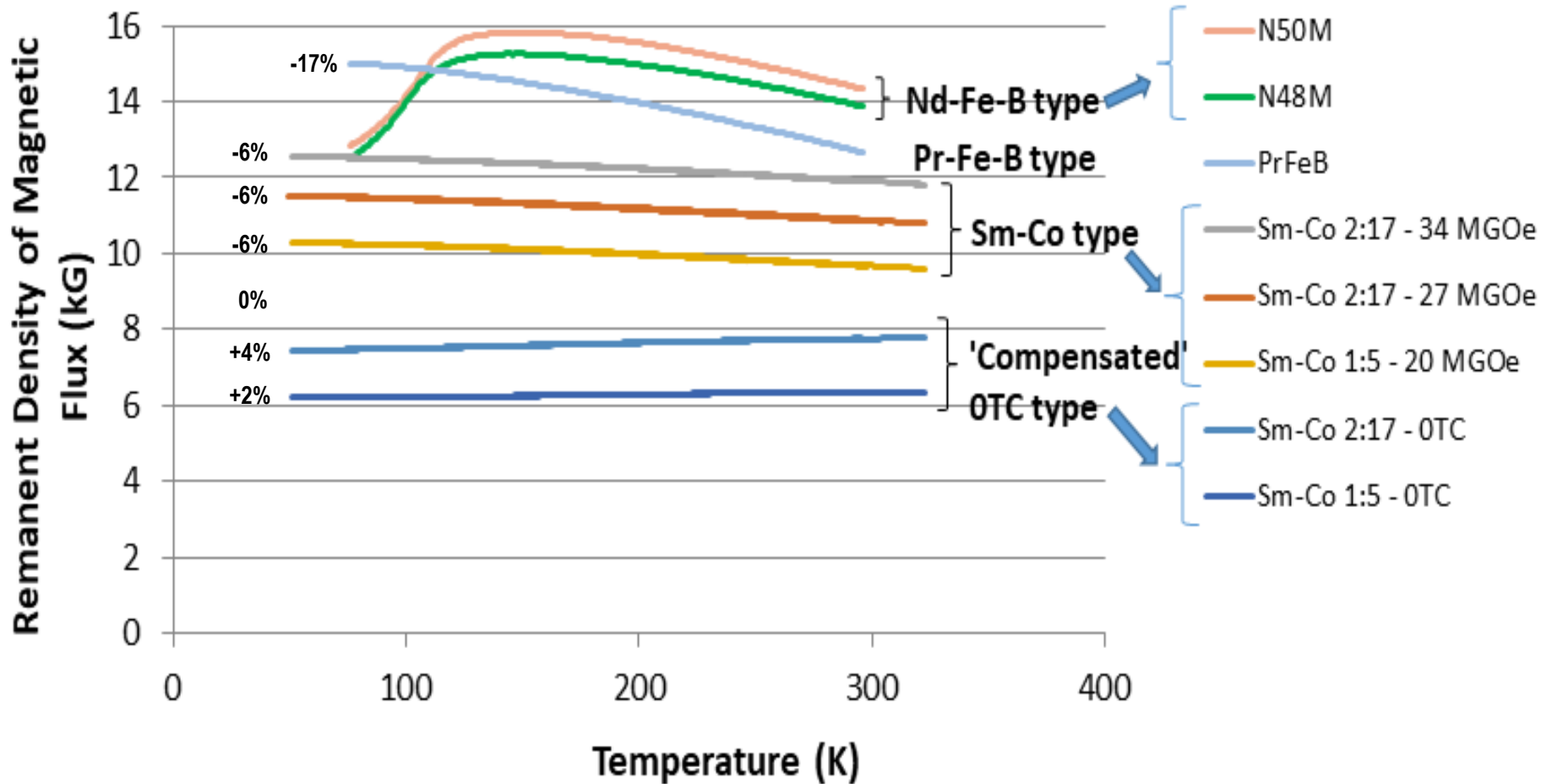

- EEC Sm-Co reversible temperature coefficient (RTC)  $-0.035$  vs.  $-0.11\%/^{\circ}\text{C}$  of Nd-Fe-B.
- EEC Sm-Co magnets provide the better thermal stability.
- Nd-Fe-B and Pr-Fe-B magnets provide the higher flux strength than Sm-Co magnets, however, they would require electromagnets for precision control due to the flux variation vs. temperature.

# Magnets vs. Radiation

[THERMAL STABILITY AND RADIATION RESISTANCE OF SM-CO BASED PERMANENT MAGNETS, Proceedings of Space Nuclear Conference, Boston, Massachusetts, June 24-28 2007]

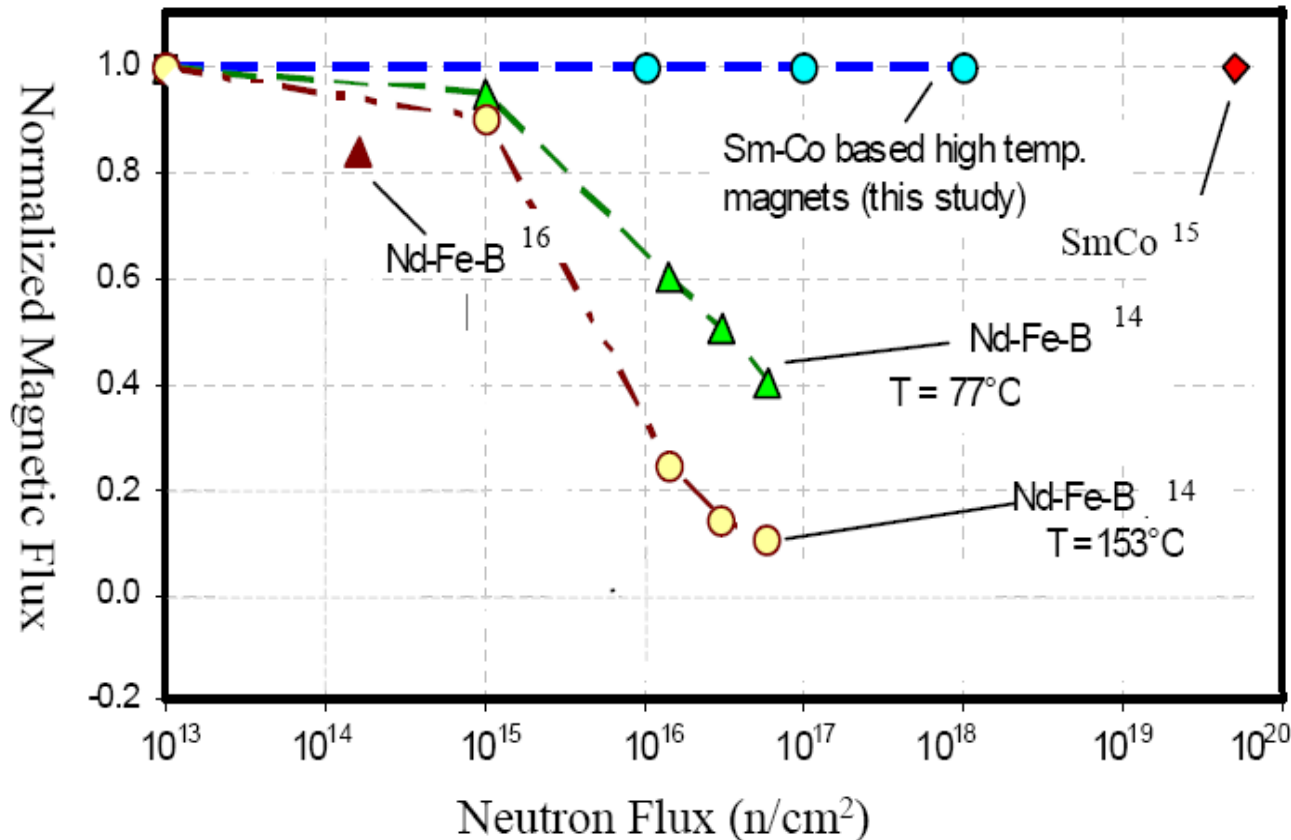

- The major radiation damage in magnet is caused by radiation-induced thermal spike accompanied by a localized temperature, especially when exceeding the curie temperature  $T_c$  of magnets.
  - **Sm-Co's  $T_c$  is 750~825°C** depending on the grades. **Nd-Fe-B's  $T_c$  is 320°C.**
  - **Sm-Co** exhibits significant demagnetization when irradiated with a **proton beam of  $10^9$  to  $10^{10}$  rads.**
  - **Nd-Fe-B** loses all of the magnetization at  **$10^6$  to  $10^7$  rads.** [A.F. Zeller and J.A. Nolen, National Superconducting Cyclotron Laboratory, TRIUMF, 1985]
  - Coating and pre-exposure to expected radiation levels to aid thermal stability is recommended.
- [Thermal Stability and the Effectiveness of Coatings for Sm-Co 2:17 High Temperature Magnets at Temperatures up to 550°C, MMM-Intermag 2004\_]



# Traveling Wave Tube Applications

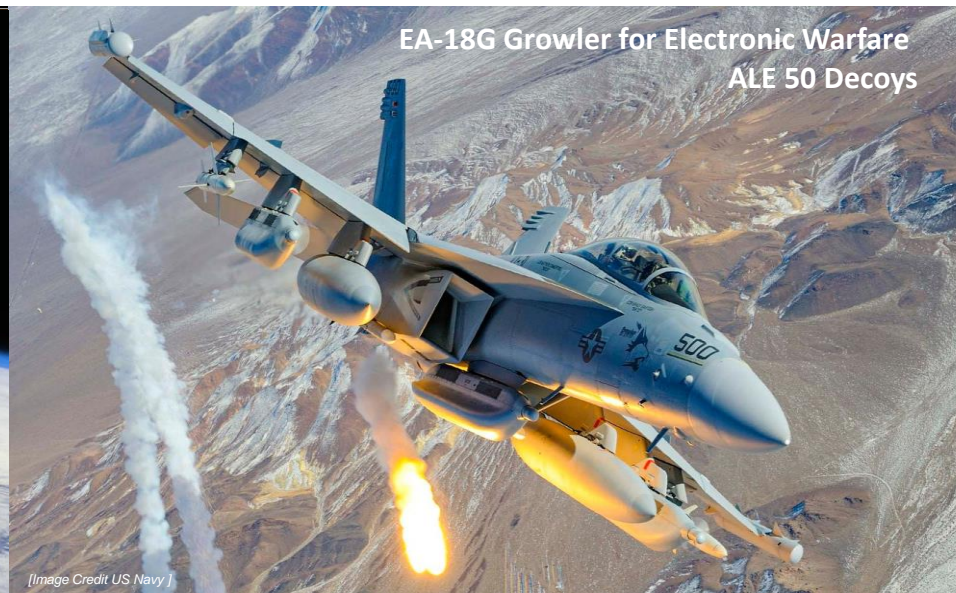



# What is Traveling Wave Tube?

- Traveling wave tubes (TWTs) **amplify radio frequency waves** by converting electron beam energy into microwave energy.
- EEC magnets and assemblies are used in sophisticated, performance-critical components of advanced technology systems, such as traveling wave tubes (TWTs), klystrons, and magnetrons. These are all used to **amplify signals at microwave frequencies for high-performing radar, communications and electronic countermeasure systems.**

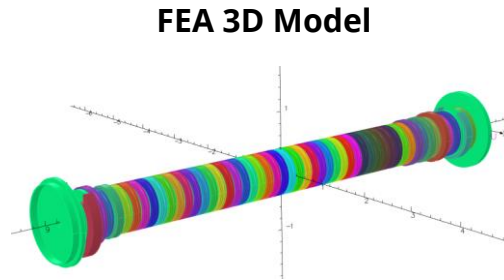
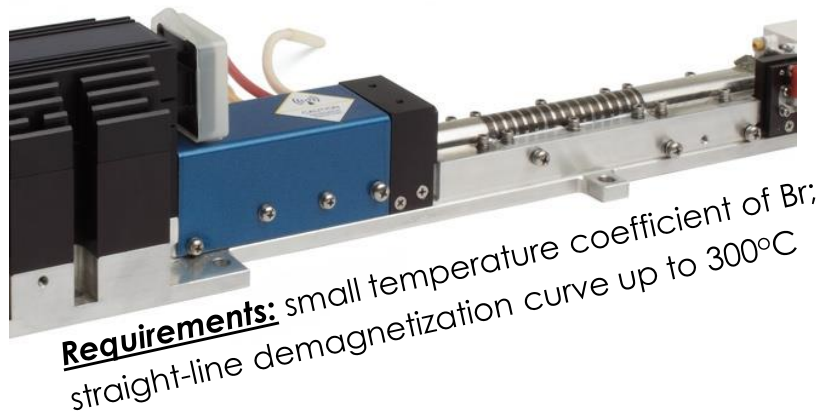

**Typical Axial Field Profile**

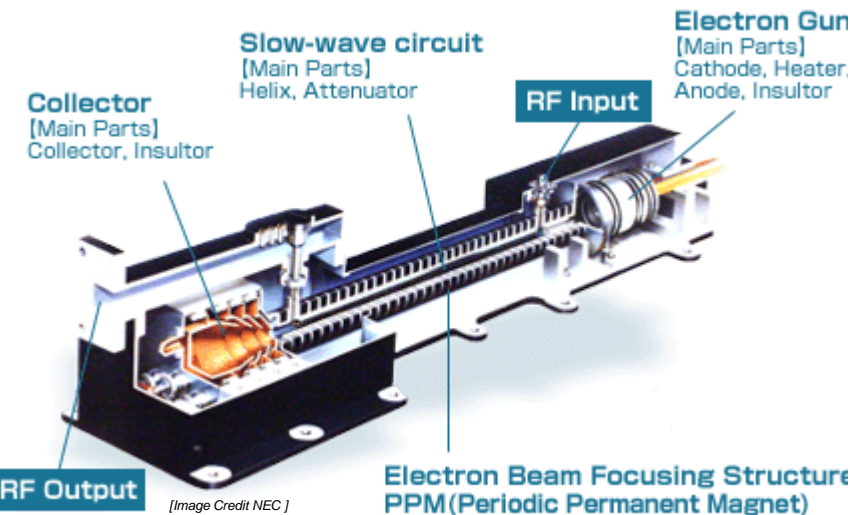
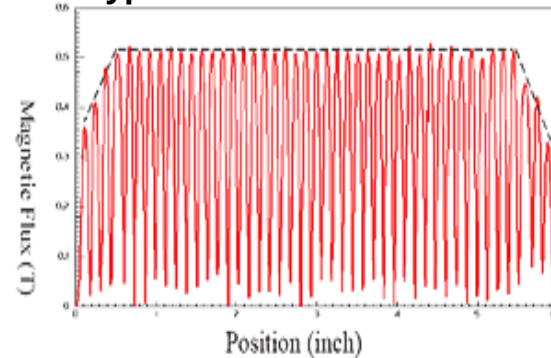

**PRINCIPAL COMPONENTS OF A HELIX TWT**

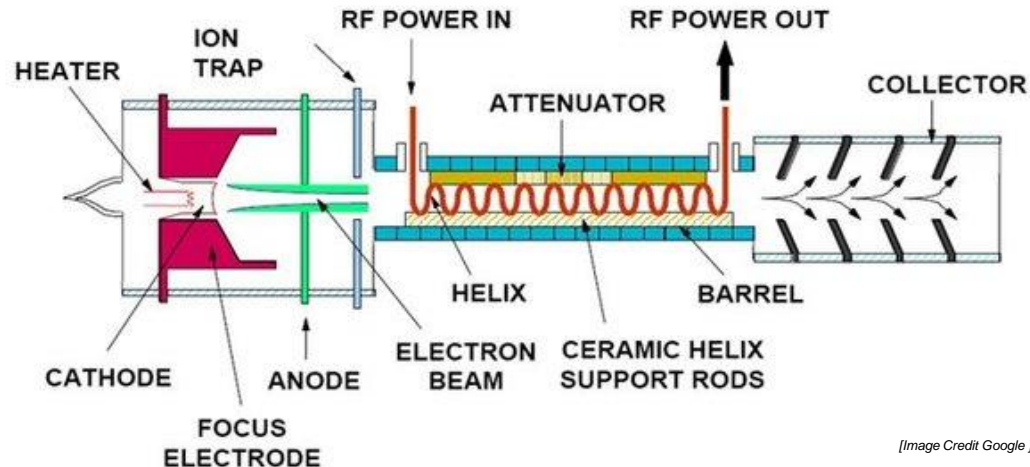

# Klystron Applications



**Applications of THz waves: Ultra-high speed communication, non-destructive imaging (security check) and material analysis**

0.094 THz image of a person:  
photo (left) THz image (right)



Analysis of the terahertz spectra from a sample of diclofenac acid (Voltaren) can distinguish between the two chief forms, or polymorphs, of the drug. (Courtesy of Analytical Chemistry)

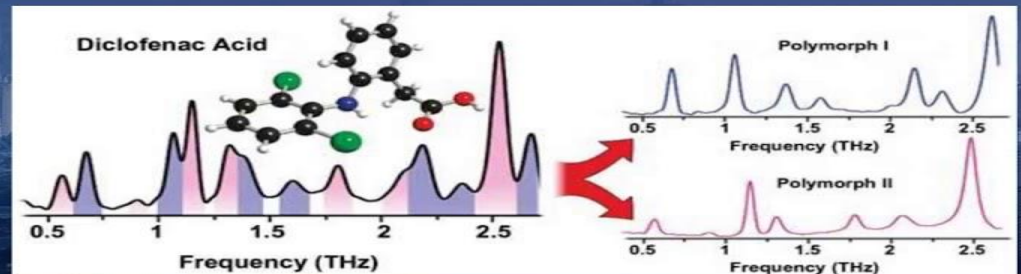



# THz Wave Technology

- **THz waves** are found between microwaves and infrared on the electromagnetic spectrum. This type of radiation can penetrate matter such as clothing, wood, paper, ceramic, and other porous material that's non-conducting..
- **Security** – Image resolution similar to that viewed with the human eye under visible light. Scanning detect explosives, plastic weapons and drugs from tens of meters away.
- **Health** - T-ray is a lot safer than an X-ray because its radiation is non-ionizing.
- **Communication** – ultra-high speed 5G data delivery exceeding 100 GBs/s, i.e., 95GHz SBK technology is 150 times faster than the current 4G network we have today.

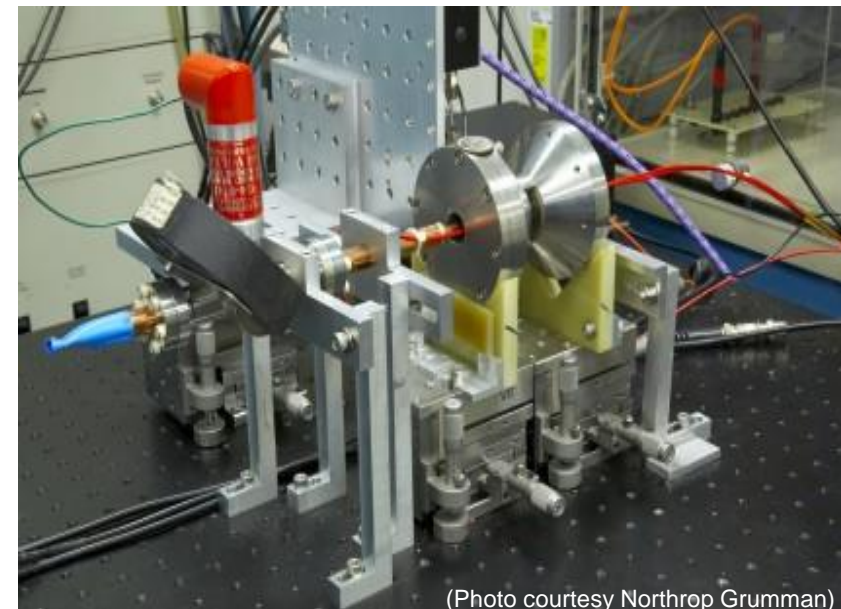
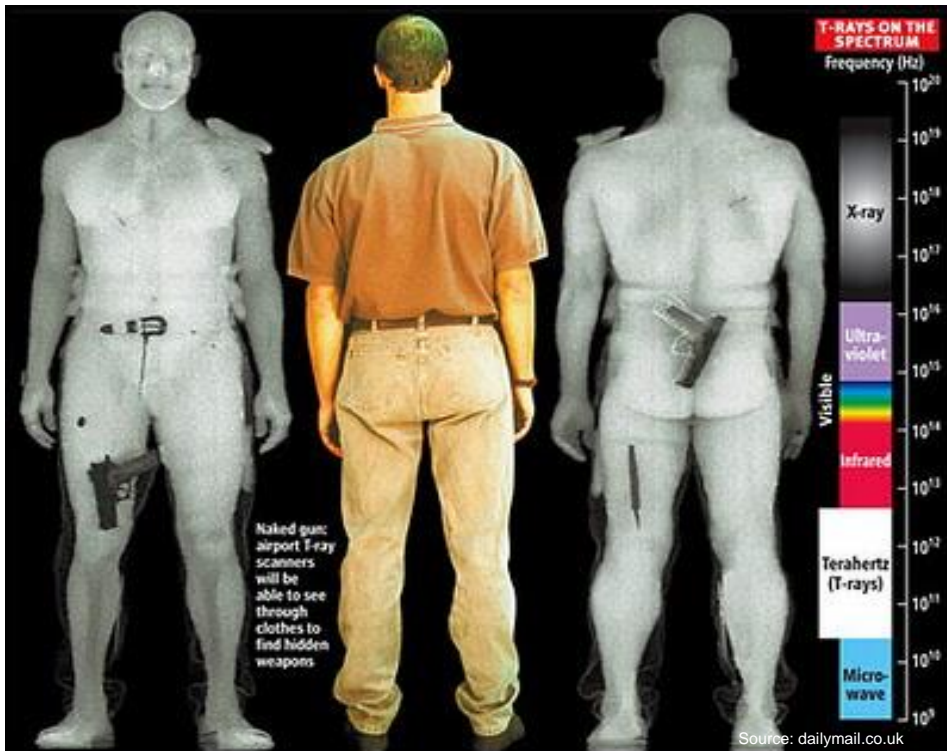

World's first THz-class traveling-wave tube amplifier.

## Non-lethal Weapon

**ADS** projects a focused millimeter wave energy beam which induces intolerable heating sensation on an adversary's skin (0.4mm deep) and cause that individual to be repelled without injury. The invisible '**pain ray**' can travel up to 500m (1,640ft).

### Pain without injury

'Active denial systems' deter attackers by sending a non-lethal millimeter-wave of electromagnetic energy, causing a burning sensation.

Wave Penetrates the skin to 1/64 of an inch, causing a feeling similar to being on fire

Two-second burst can heat skin to 130° F

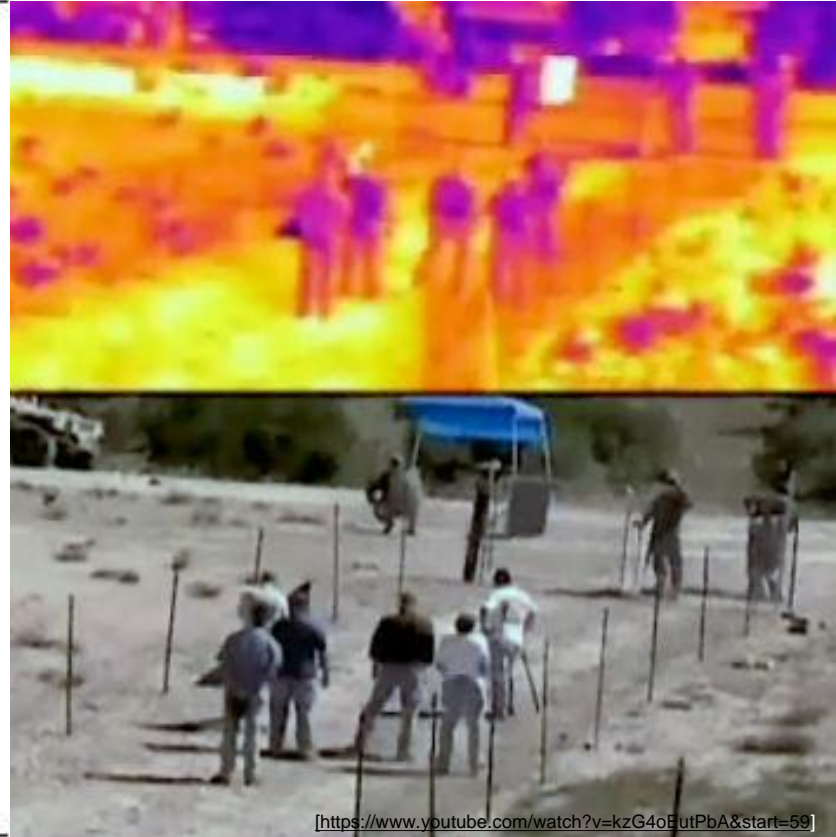
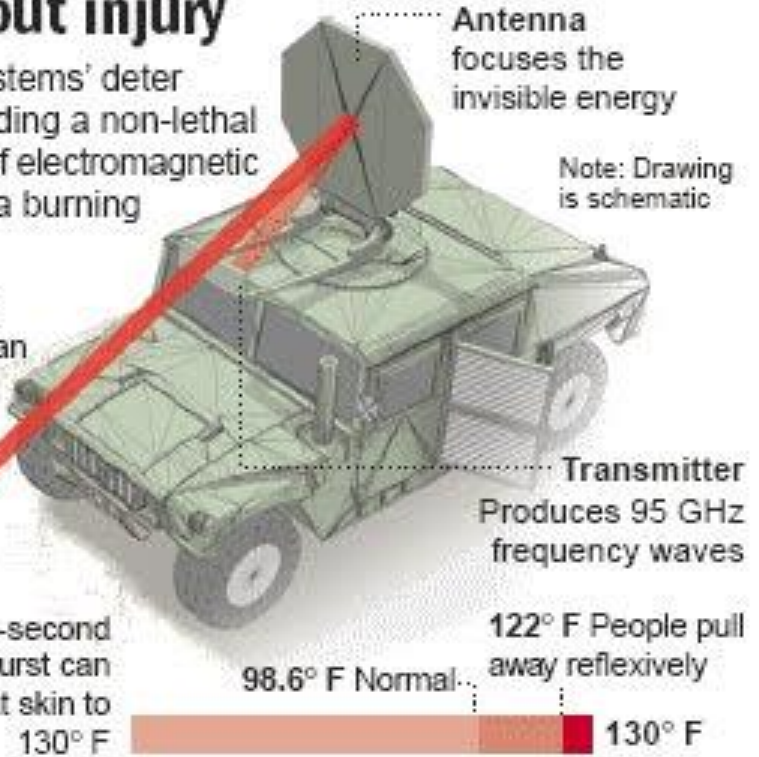

[<https://www.youtube.com/watch?v=kzG4oEutPbA&start=59>]



# Klystron Magnet Examples

## 95 GHz Klystron for Active Denial Systems

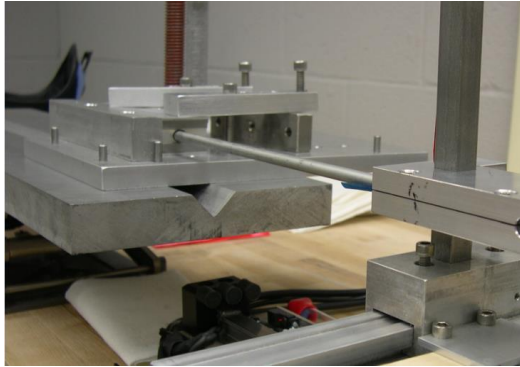

## Calabazas Creek Research for THz TWT

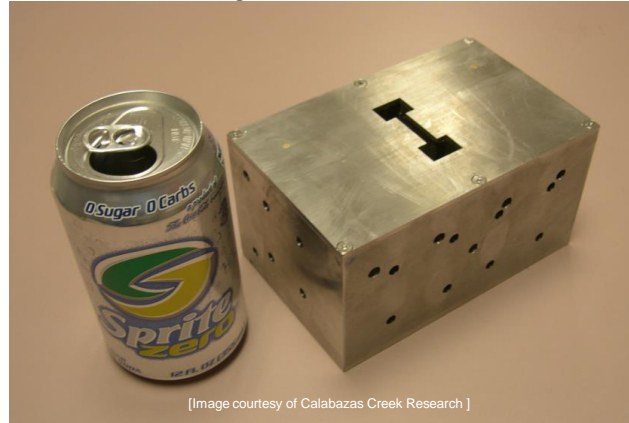

## V-band Klystron

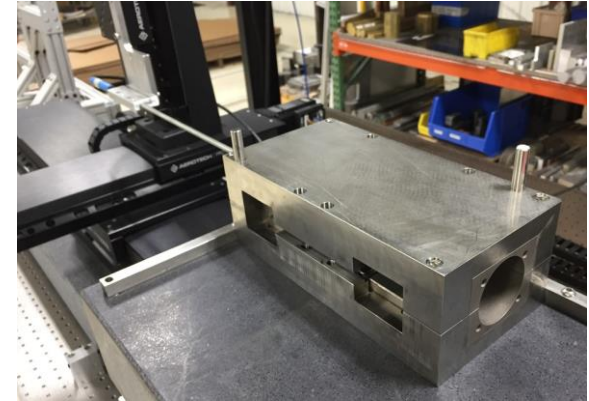

## 94 GHz Klystron for 5G Communication



## SLAC Klystron for Homeland Security

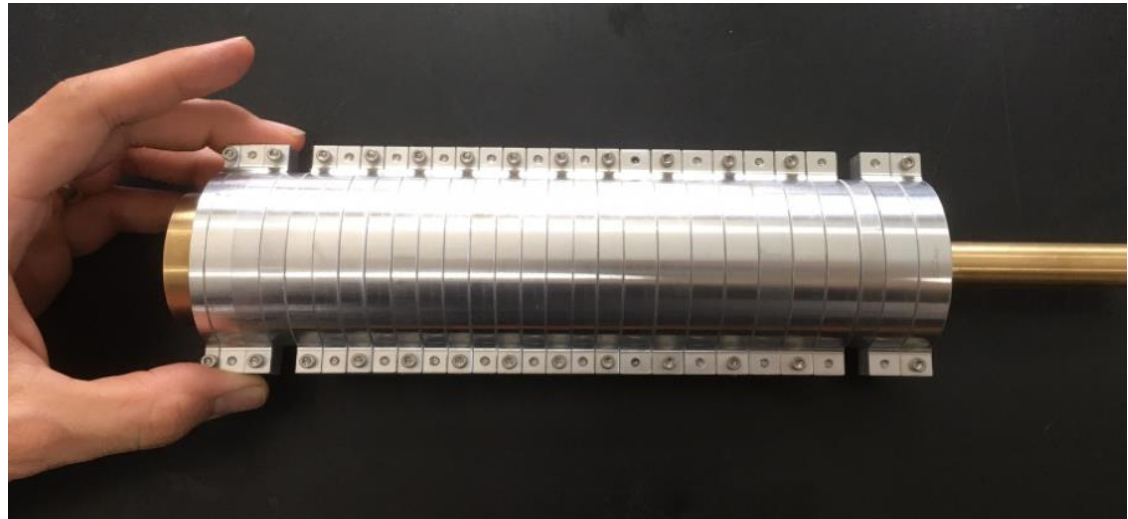

# BNL Accelerator



Kick-off meeting in April 2016 at BNL



# Quadrupole Magnet for Collider

## DOE Fast-Track Program (DE-SC0015230, 2/22/2016~3/21/2019)

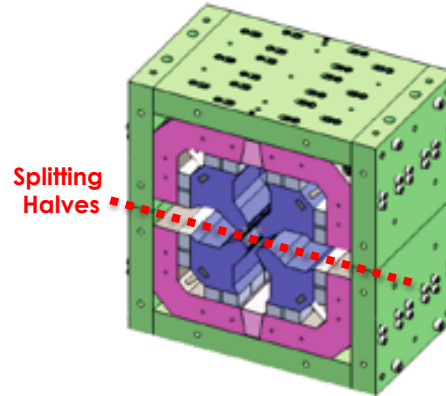
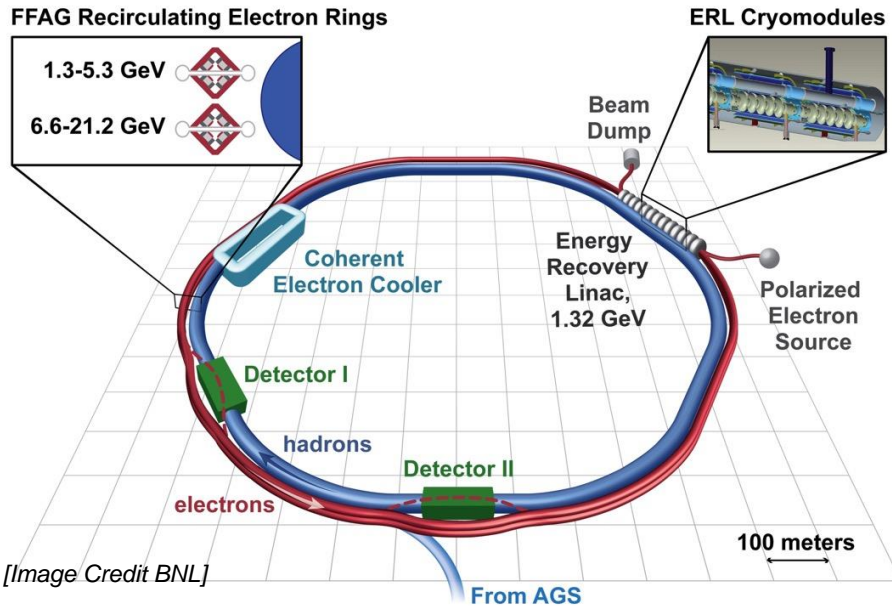

- **Iron-dominant quadrupole** for future electron ion collider (BNL eRHIC)
- **Size: 500 x 514 x 300 mm** (19.7" x 20.2" x 11.8" )
- **Weight: 470 kg** (1,040 lbs)
- Technical assistance from Dr. Holger Witte and Dr. Peter Wanderer at BNL

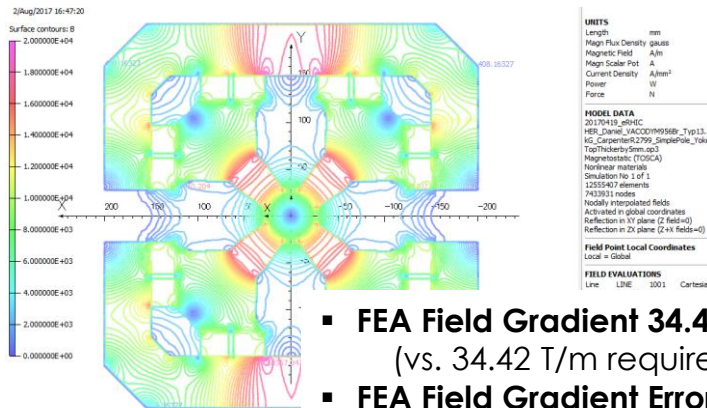
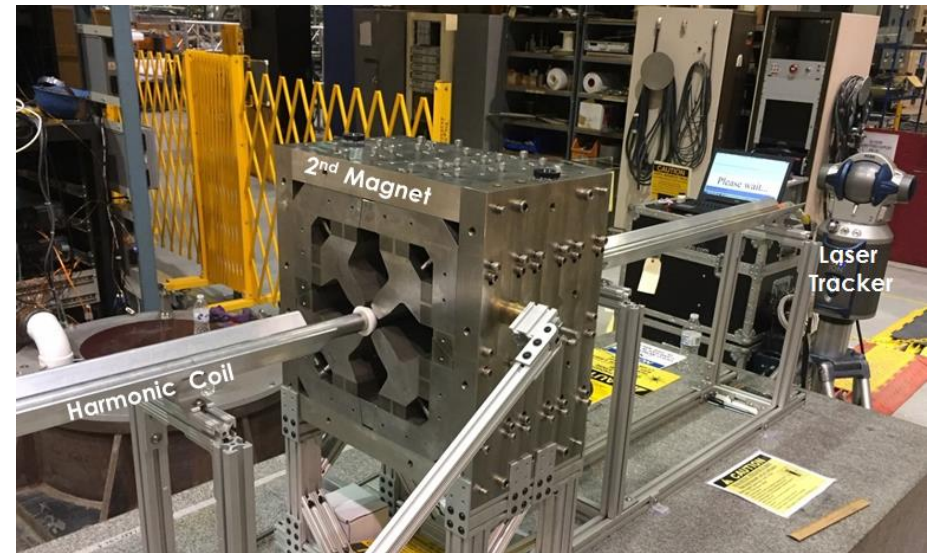

- **FEA Field Gradient 34.42 T/m** (vs. 34.42 T/m required)
- **FEA Field Gradient Error 0.02%** (vs. <0.1% required)

- **Field Harmonics are measured** using harmonics coil.
- EEC quadrupole magnets proved a unique adjusting mechanism to **improve the field harmonics.**



# Test Results

Normal Harmonics		As-is Magnet	1 <sup>st</sup> Magnet	2 <sup>nd</sup> Magnet
Dipole	b1	-	-	-
<b>Quadrupole</b>	<b>b2</b>	<b>10,000</b>	<b>10,000</b>	<b>10,000</b>
<b>Sextupole</b>	<b>b3</b>	<b>-3.14</b>	<b>-0.74</b>	<b>-0.71</b>
<b>Octupole</b>	<b>b4</b>	<b>-5.61</b>	<b>-5.67</b>	<b>-3.45</b>
Decapole	b5	-0.48	-0.23	-0.27
Dodecapole	b6	7.46	7.77	-3.52
14-pole	b7	-0.10	-0.05	-0.04
16-pole	b8	-0.09	-0.09	-0.05
18-pole	b9	0.02	0.02	0

- ✓ In reality **the Perfect Symmetry is challenging** in terms of the magnetic and mechanical tolerance.
- ✓ **Octupole error** from imperfect geometrical symmetry → **Solution: Shunt & Corrector.**
- ✓ Sextupole harmonics can be improved by the tunable magnets.
- ✓ Limitation 1: The harmonics coil test doesn't tell where the strong/weak field positions, which requires another field mapping at each measurement.
- ✓ Limitation 2: In reality it is hard to adjust mechanically due to the limit of laser tracker resolution .001" and tweak magnetically the field associated with the harmonics data.

# Challenges & Solutions

## Challenge 1. Harmonics Limitation

**Solution 1.** Corrector/shunting coils would help to improve the harmonics by adjusting the non-symmetric field. Like the permanent magnet based Halbach quadrupole magnets for CBETA, it would be possible to adjust magnetically the field harmonics using the corrector coils. Based on the FEA of our quadrupole magnet, the field tuning capability is 0.09% ( $\Delta B/B \leq 9 \times 10^{-4}$ ) with four outermost conductors and current density  $2.06 \text{ A/mm}^2$  (25 AWG, 0.457A, 18 Turns,  $4\text{mm}^2$ ).

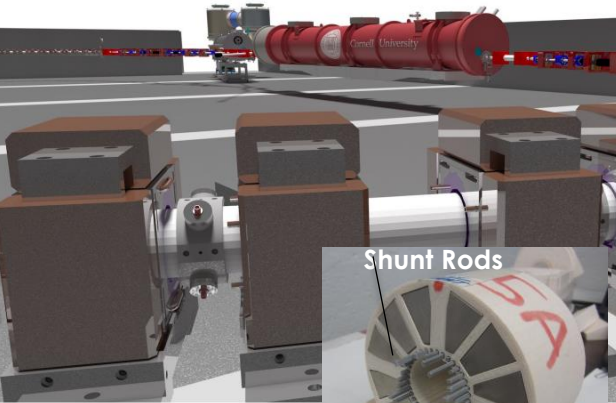

Christopher Mayes – September 9, 2017

[Image Credit BNL, 2018]



Georg Hofstaetter@cornell.edu - September 8, 2017

## Challenge 2. Mechanical Adjusting Limitation

**Solution 2.** Mark Jaski's idea of 8-pieces quadrupole concept would enable not only to adjust easily the tips of each pole using crisscross dowel pins, but also provide a simple method for producing a quadrupole using standard machining techniques, which could result in a final tolerance accuracy of the resulting construct better than ours and improve the geometrical symmetry.

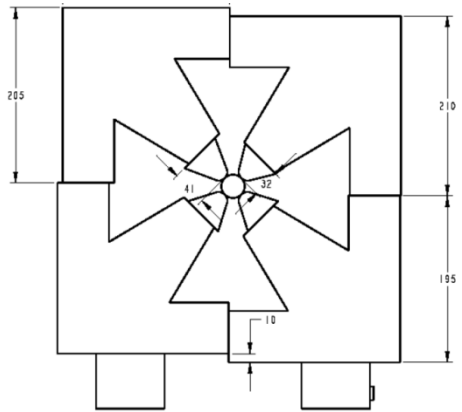
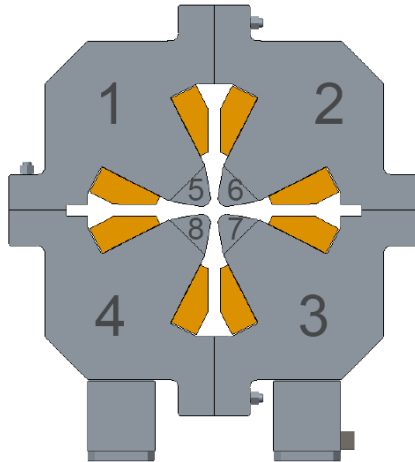

[Image Courtesy Mark Jaski, ANL]

# Halbach Quadrupole Magnets for Proton Therapy

## Treating cancer with protons

Proton therapy is a kind of radiation used to kill cancer cells and stop them from growing. Doctors can better aim proton beams onto a tumor, so there is less damage to the surrounding healthy tissue. This allows doctors to use a higher dose of radiation with proton therapy than they can use with X-rays. Proton therapy can treat cancers of the brain, eye, head and neck, lung, spine and prostate.

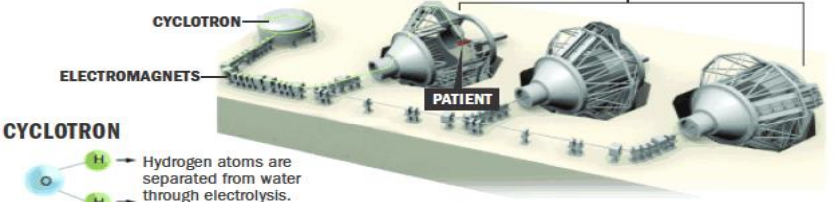

**CYCLOTRON**  
Hydrogen atoms are separated from water through electrolysis.  
The positively charged protons are extracted from the hydrogen atoms and injected into the cyclotron.

Within fractions of a second, the cyclotron accelerates the protons to two-thirds the speed of light using electric fields.

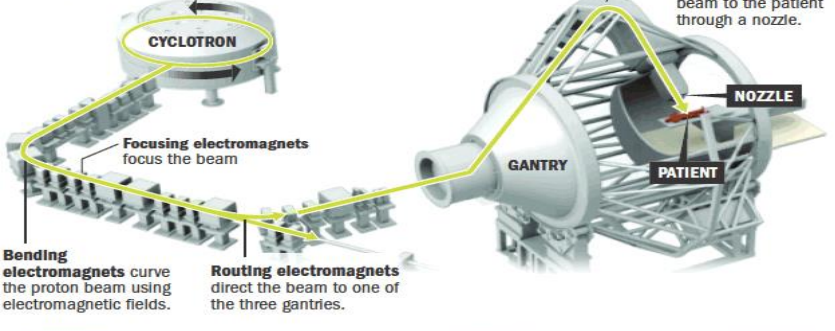

A 21,000-pound magnet guides the beam to the patient through a nozzle.

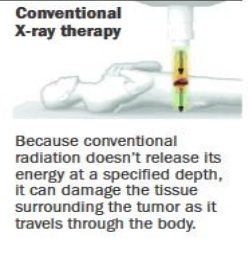
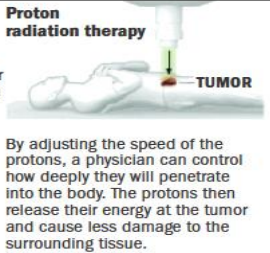
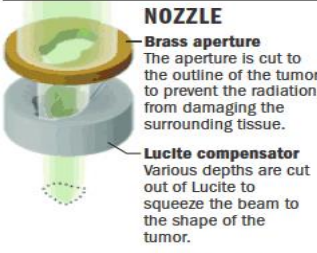

By adjusting the speed of the protons, a physician can control how deeply they will penetrate into the body. The protons then release their energy at the tumor and cause less damage to the surrounding tissue.

Because conventional radiation doesn't release its energy at a specified depth, it can damage the tissue surrounding the tumor as it travels through the body.

- EEC made Halbach quadrupole magnets are in use for magnetic focusing of the proton radiology at Loma Linda University Medical Center.
- Since 2015, more than a dozen quadrupole magnets demonstrates a required field gradient ranging from 100 to 260 T/m within a 10~20 mm bore.
- 24-segments Halbach magnets produce high quality quadrupole fields suitable for proton radiosurgery.

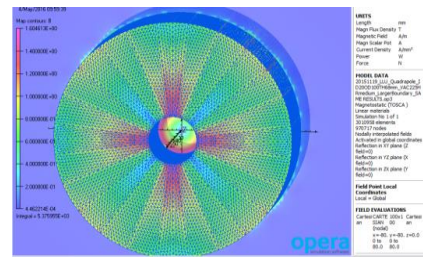

Fig 4. FEA Magnetic field distribution (field gradient 150 T/m, 1.5T at pole)

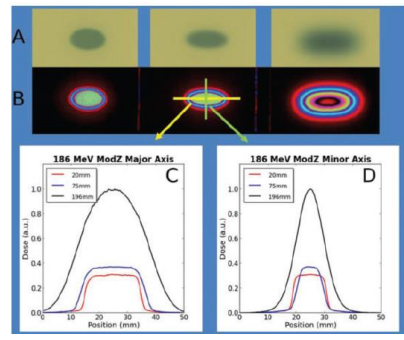

Fig 6. Beam spot symmetry of 186 MeV focused proton beam revealed in EBT2 film (A & B) and diode detector (C & D) data is indicative of quality quadrupole fields.

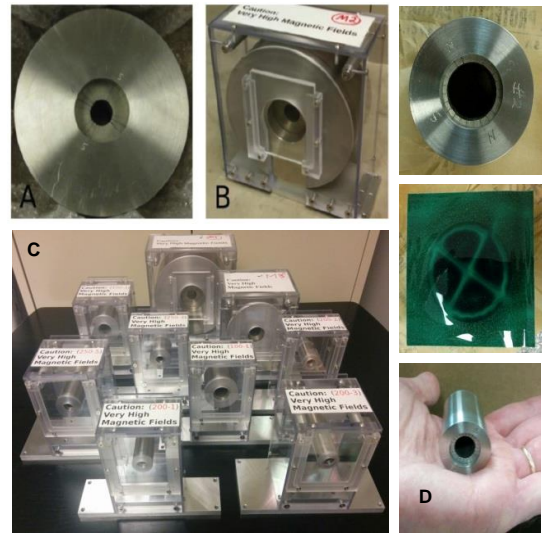

Fig 5. Focusing magnets consist of 24 segments of  $Sm_2Co_{17}$  material adhered into Halbach cylinders and encased in nonmagnetic stainless steel and placed in Lexan safety/mounting cases.

[H. Choi, L. Haley, J. Liu, G. McAuley, and A. Wroe, 'Design and Development of Permanent Magnet Based Quadrupole for Proton Radiosurgery Applications', Proceedings of the 24th International Workshop on Rare Earth and Future Permanent Magnets and Their Applications (REPM 2016), August 28–September 1, 2016, Darmstadt, Germany.]

Sources: The New York Times, University of Florida Proton Therapy Institute, National Institutes of Health



# Adjustable Halbach Quadrupole



[Image Courtesy Emilio Nanni/SLAC]

## Tunable Quadrupole Magnet with Splitter Stand

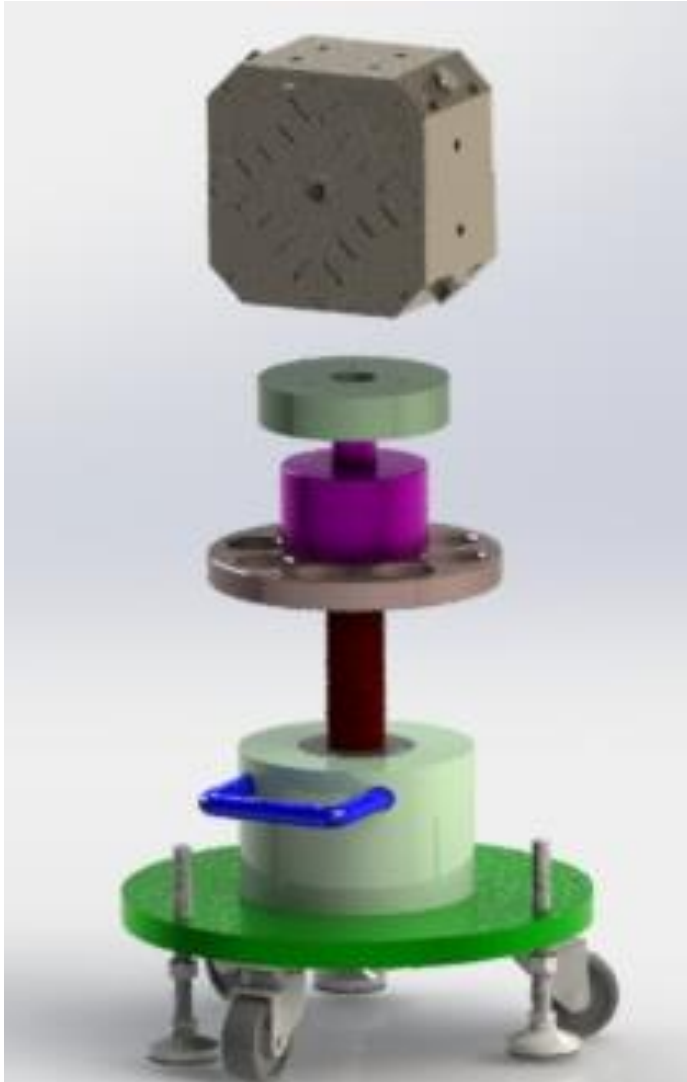

### 16-Segments Halbach Quadrupole

- EEC Sm<sub>2</sub>-Co<sub>17</sub> 31 material
- Magnet size ID 17 x OD 140 mm
- Magnet length 120 mm
- Shield OD ~240 mm
- **Adjustability up to 44% (202~114 T/m)**

### Innovation 1

- **Thermally compensated EEC Sm-Co magnets** minimize the field variation against the thermal drift (77~82 K).

### Innovation 2

- **Unique tuning approach** enables the magnets to provide the minimum field gradient while maintaining the required field harmonics.

### Innovation 3

- **4-arc modular magnets** attract together magnetically while 4 subassemblies in each quarter repel each other, which is helpful in controlling magnets and **splitting halves**.



# Adjustable Phase Shifter



Kick-off meeting in November 2016 at SLAC



# Adjustable Phase Shifter Magnet

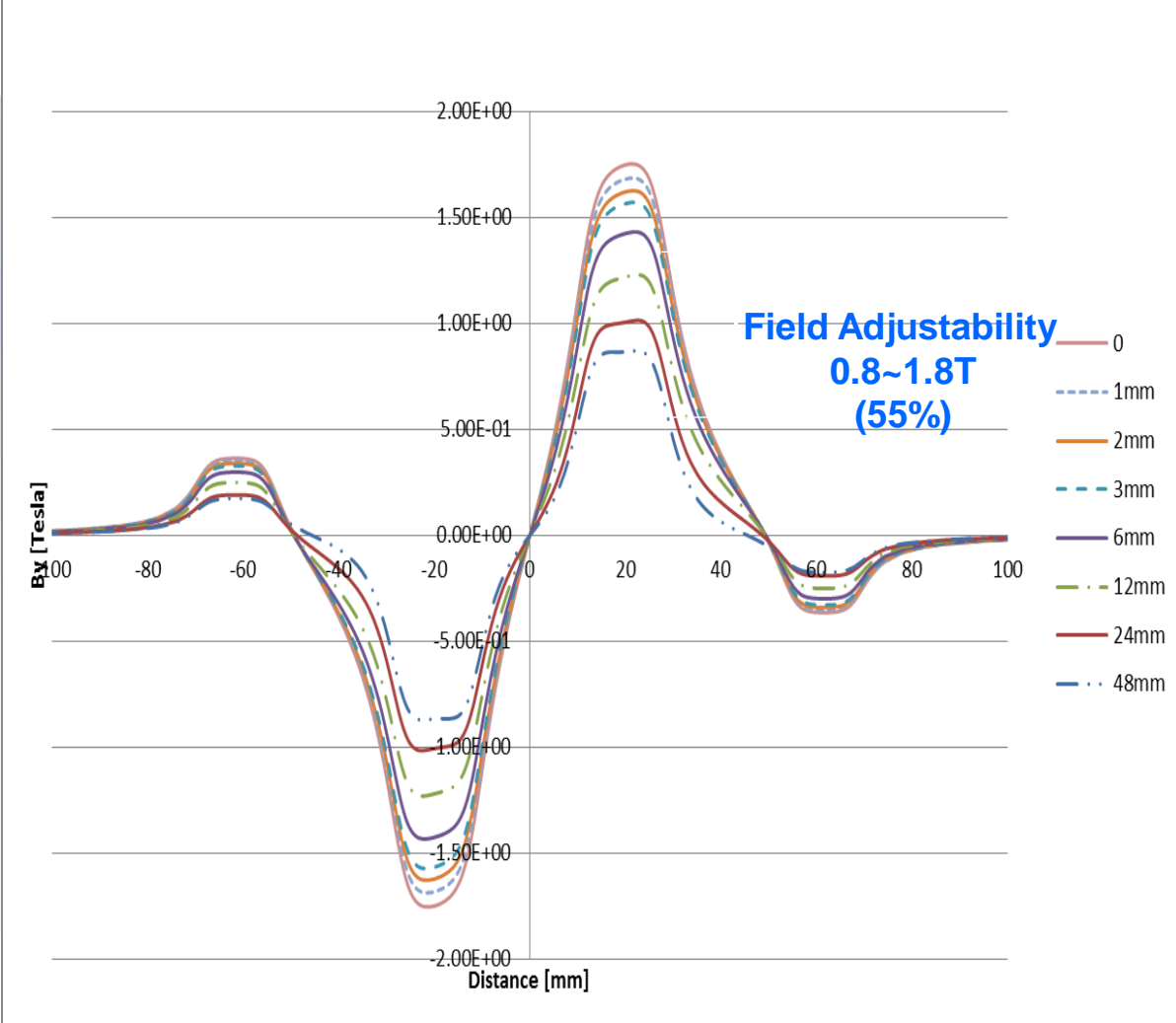
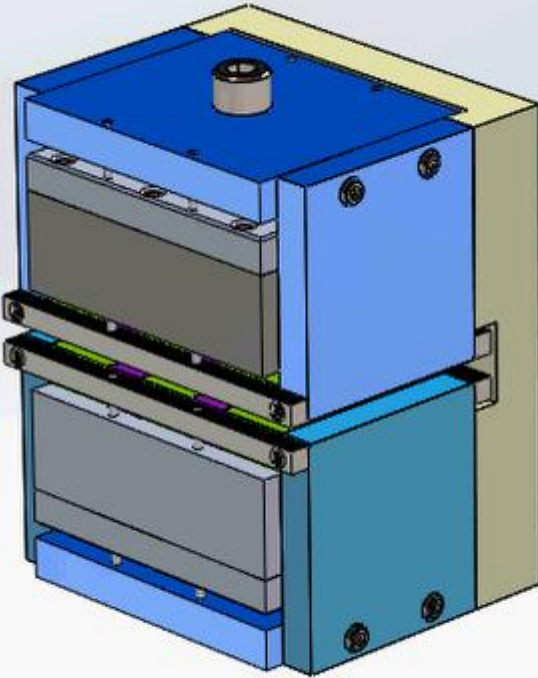

# Electromagnet to Permanent Magnet





# Change the Way to Define the Kilogram 11/16/18

**Kibble Balance** is the electromechanical weight measuring instrument to define a kilogram mass by comparing electrical power to mechanical power.

[NIST-3 Superconducting Magnet]

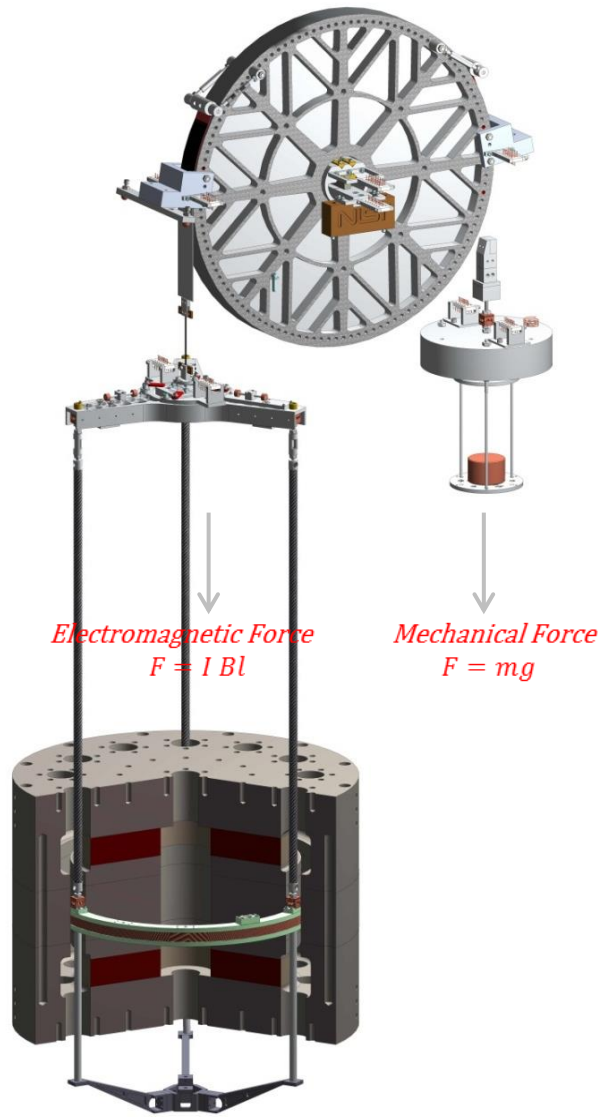

[NIST-4 Watt Balance installed underground 2014]

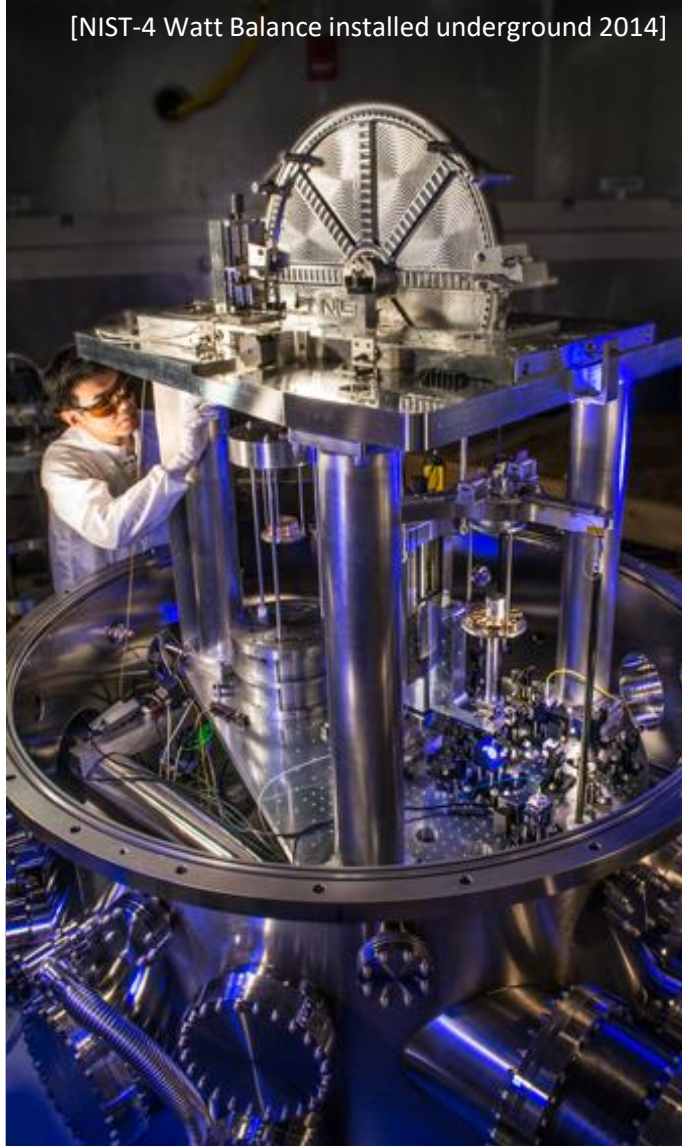

[NIST-4 Permanent Magnet]



Magn

[Image Courtesy NIST]



# EEC Temperature Compensated Magnet

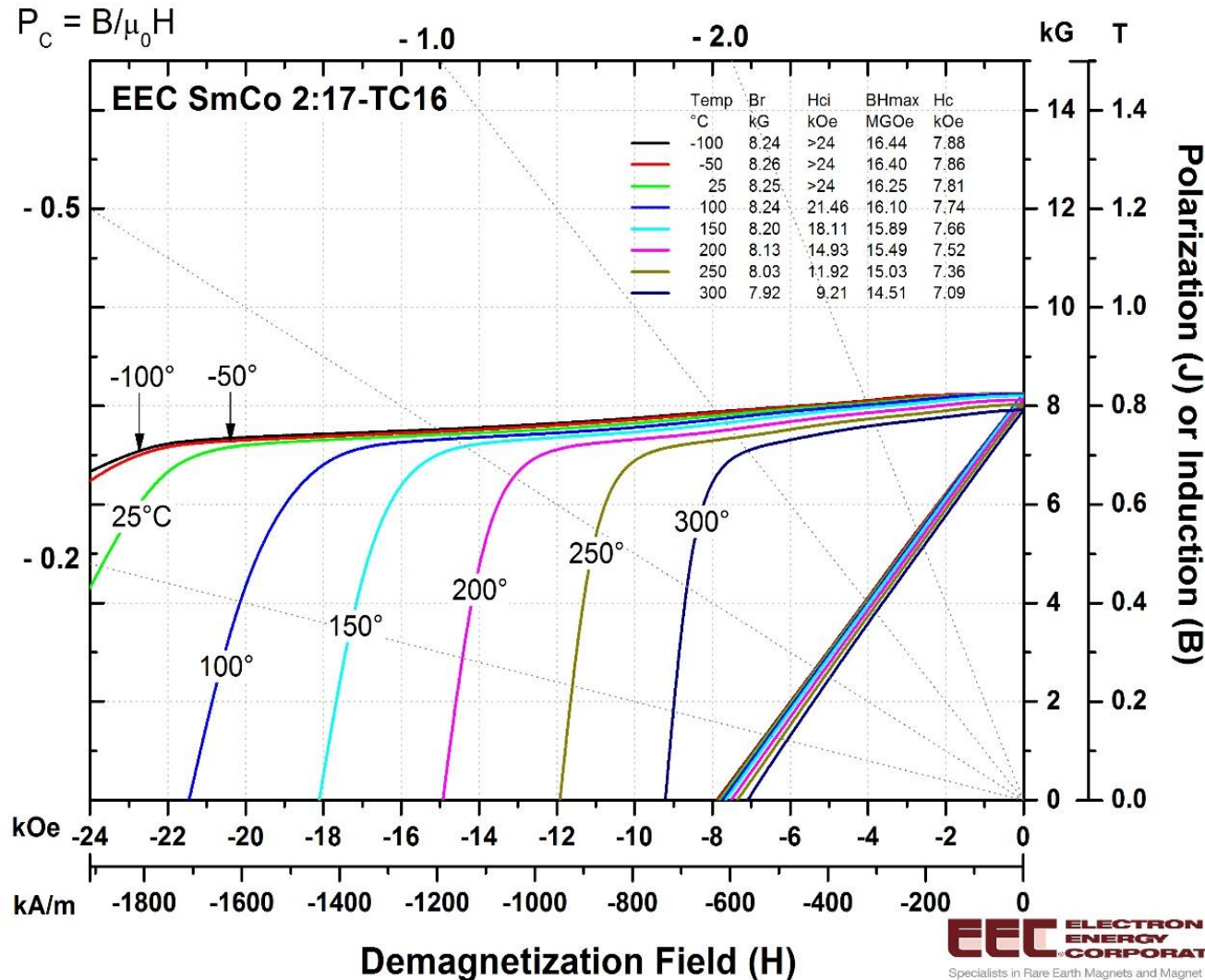

## What is 'TC' Magnet?

EEC TC magnet material, developed in 2009, shows no change in the magnetic field over a wide operating temperature (**Sole Manufacturer**).

## Why Important?

- 1) Reversible temperature coefficient of Br <math>-0.001\%/C</math> vs. - 2) Straight normal BH curves,
- 3) **Strong thermal stability** to temperature and radiation,
- 4) High corrosion resistance.

## When Needed?

- 1) High precision electronics such as TWT, gyro, klystron, accelerator, torquer, imaging, ADS
- 2) State-of-the-art technologies like Kibble balance, beam focusing, quantum diamond magnetometer.

# Quantum Diamond Magnetometer

## What is it?

- ✓ Next-generation scanning probe microscope that utilizes a so-called nitrogen-vacancy (NV) center as an atomic size magnetic field sensor.
- ✓ Because NV centers show quantum behavior even at room temperature, the scanning NV magnetometer can exploit quantum metrology techniques to achieve very high magnetic field sensitivity.

## How it works?

- ✓ The scanning NV magnetometer records the interaction of the NV center with the local magnetic field.
- ✓ As the magnetic field at the location of the NV center increases, the magnetic interaction becomes stronger – more energy is required to flip the magnetic orientation of the NV center. This energy can be probed by the technique of electron paramagnetic resonance (EPR) spectroscopy.

## What Applications?

- ✓ Quantitative analysis of current distributions in semiconductors, graphene devices, photoactive films, integrated circuits.
- ✓ Vector field analysis of magnetic domains, defects, and nanostructures.
- ✓ Nanoscale thermometry.
- ✓ Imaging of biomagnetic structures and nanoparticle markers.
- ✓ GPS.

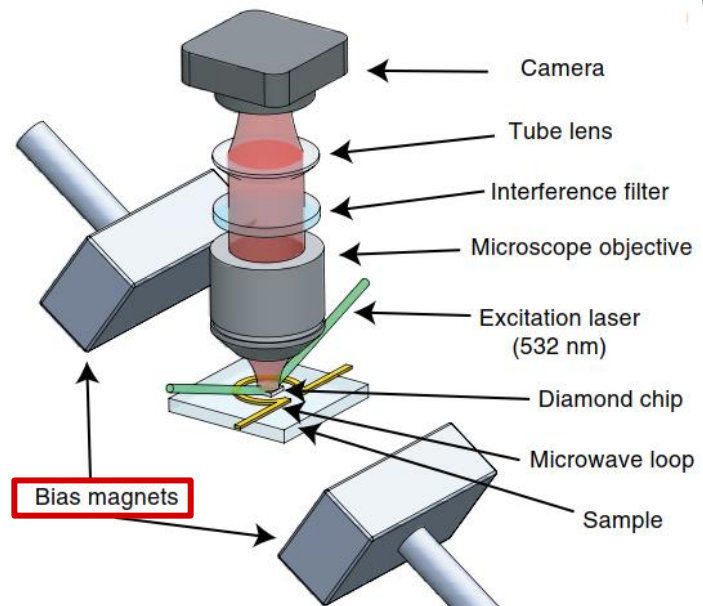
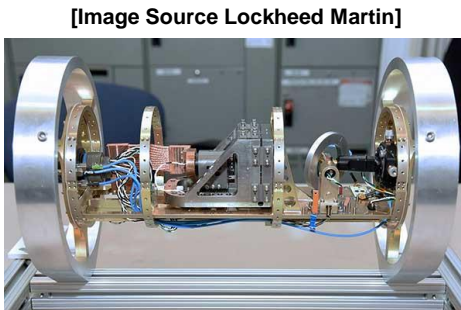

[Source: [http://walsworth.physics.harvard.edu/publications/2019\\_Turner\\_Nanophotonics.pdf](http://walsworth.physics.harvard.edu/publications/2019_Turner_Nanophotonics.pdf)]

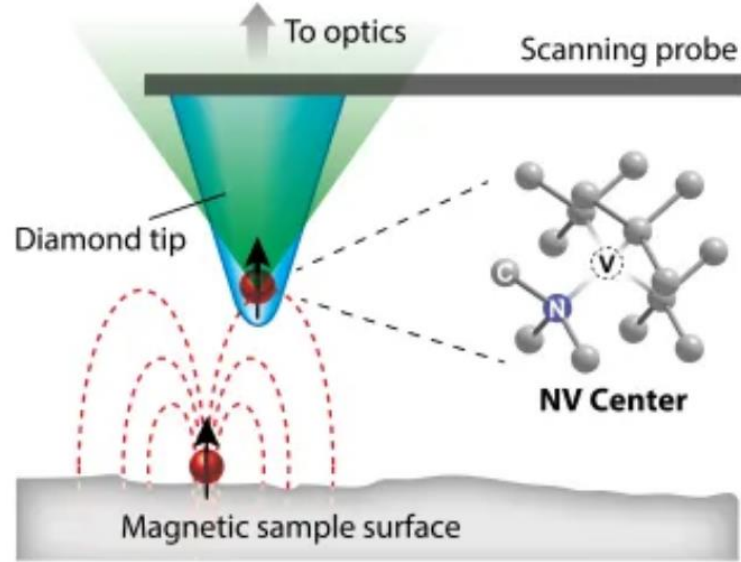



# Precision Gyroscope

The \$2.5 billion robotic explorer, landed on the Red Planet Aug. 6, 2012.

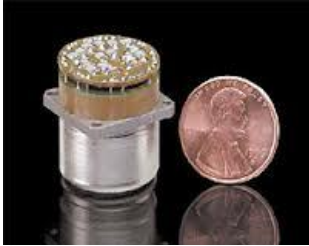

**EEC Magnets are used in gyro systems for Curiosity Rover on Mars.**

## NASA Mars mission

The Curiosity rover is designed to travel Mars studying climate and geology. The rover is looking for signs of carbon, the building blocks of life. Some of the rover's features:

<p><b>Robotic arm</b> Used to examine and manipulate soil and rocks; it also has two scientific instruments, one uses X-rays to determine materials' composition and the other is a magnifying camera</p>	<p><b>Laser</b> Burns small holes in rocks and soil up to 23 feet away and identifies chemical elements</p>	<p><b>Color cameras</b> Stereo mastcams on either side of the rover's mast take color pictures and movies in 3-D</p>	<p><b>UHF antenna</b> Primary transmission antenna</p>
<p><b>Weather station</b> Records wind speed/direction, air pressure, humidity, temperature and UV radiation</p>	<p><b>Radiation detector</b> Measures radiation from the sun, supernovae and other sources</p>	<p><b>Chemistry lab</b> Analyzes rock and soil samples for organics</p>	<p><b>Neutron detector</b> Detects water in rocks and soil</p>
		<p><b>Mineral detector</b> Shines an X-ray beam at a rock or soil sample to identify types of minerals</p>	<p><b>Plutonium power source</b> A nuclear battery that converts heat into electricity</p>

Photo courtesy of NASA

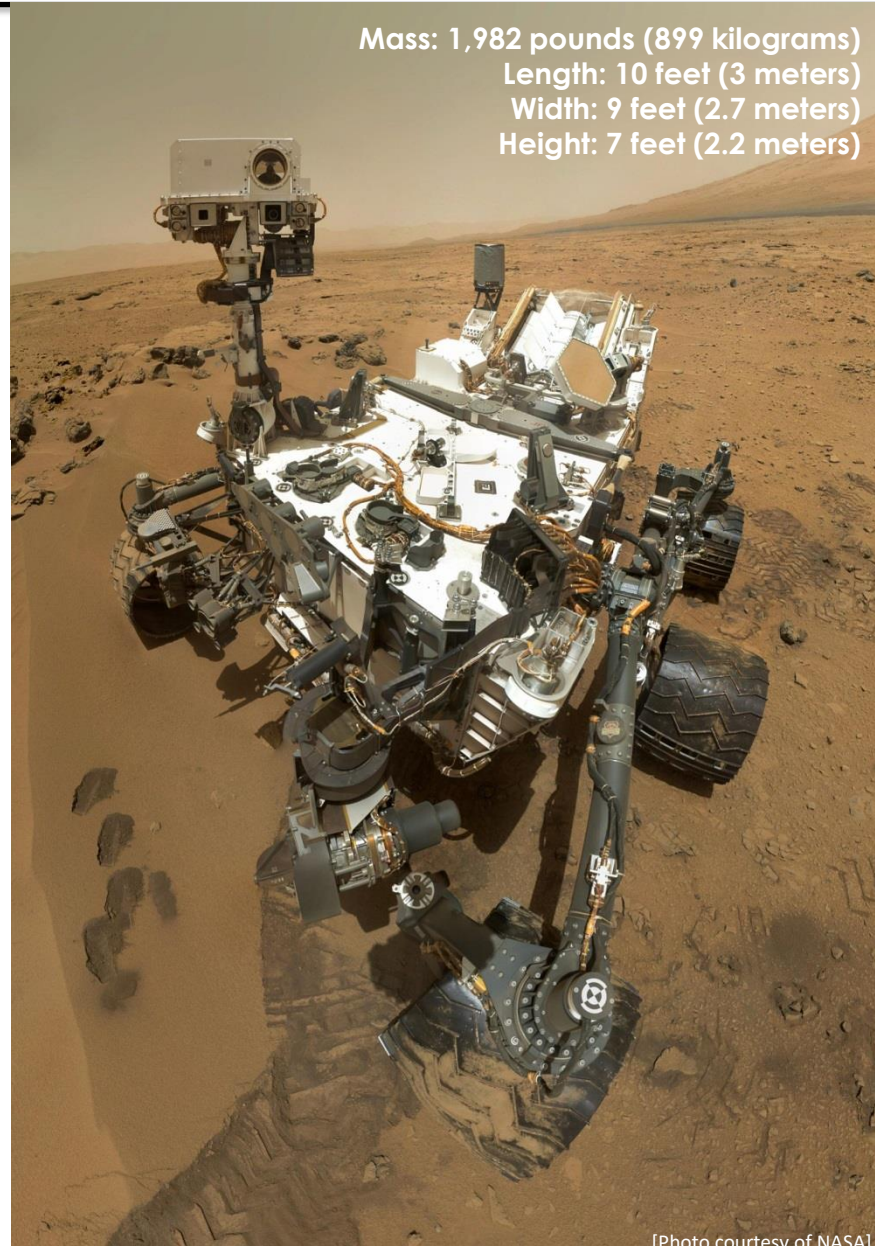

Mass: 1,982 pounds (899 kilograms)  
Length: 10 feet (3 meters)  
Width: 9 feet (2.7 meters)  
Height: 7 feet (2.2 meters)



# Precision Guidance

The **precision guidance** enables the rescue team to accurately target the starting point of the drill hole, then carefully control the orientation and direction of the drill hole to hit the target with the help of EEC magnets.

## Chilean Miners Rescue Plan

Chilean rescuers spent 40 days drilling a borehole in an effort to save the Chilean miners trapped under the earth at the depth of 700 meters since August 5



www.theguardian.com

### San Jose Mine

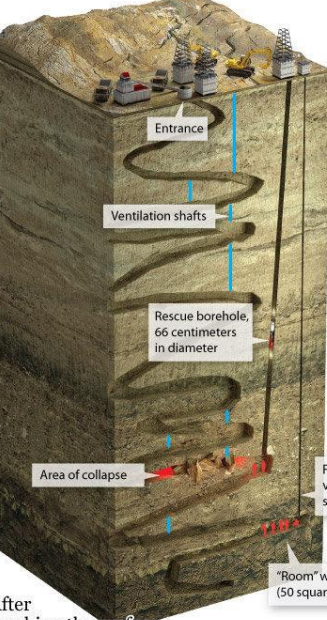

### Phoenix rescue capsule

Three capsules have been designed specially for the operation

The shaft has special belts to monitor the blood pressure, temperature, pulse and breathing rate

Oxygen system

Communication system

Safety belts

First borehole (which provides ventilation of the shaft and supplies to the miners)

"Room" where miners stay (50 square meters)

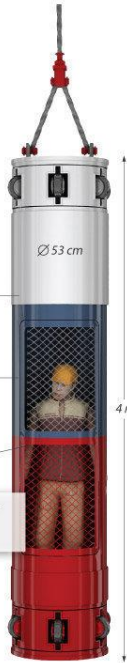

### Stages of rescue operation

- 1** Drilling a borehole with a pneumatic hammer that throws the earth to the surface
- 2** Increasing the diameter size of the borehole to 66 centimeters (26 inches) with the use of a bar with a cutter
- 3** Descent of two volunteers (mine specialist and military doctor) to test the capsule
- 4** Pulling up the miners one by one to the surface in the rescue capsule

### After reaching the surface:

- miners will be given dark glasses to protect their eyes from bright sunlight
- miners will undergo a medical examination
- miners will be delivered to a field hospital installed near the mine
- once the condition of the rescued miners stabilize, they will be transferred to a medical center in Copiapo in the Atacama Region



08/11/2012

Photo by H. Choi at Smithsonian Museum



08/11/2012

Drill bit

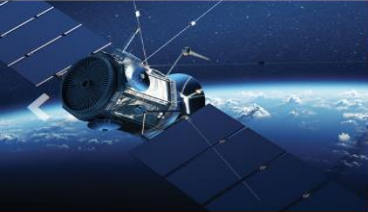

ENGINEERED MAGNETIC SOLUTIONS – ELECTRON ENERGY CORPORATION

# THANK YOU

**Heeju Choi, Ph.D.**

Principal Engineer

Electron Energy Corporation

924 Links Avenue, Landisville, PA 17538, USA

[www.electronenergy.com](http://www.electronenergy.com)

## Acknowledgements

Part of this material is based upon work supported by the U.S. Department of Energy, Office of Nuclear Energy, under Award Numbers DE-SC0015230, DE-SC0019537, DE-SC0021719. This financial assistance from DOE is gratefully acknowledged.

## Does a rare earth magnet lose it's strength?

### Permanent magnet could lose strength if:

- ✓ the working temperature exceeds the specified maximum operating temperature; (thermal demagnetization)
- ✓ the magnets are demagnetized by external magnetic field; (electrical / magnetic demagnetization)
- ✓ the magnets are heavily corroded or oxidized.



## What are the coating options?

### Sm-Co Magnets

**No coating** is required.

### Nd-Fe-B Magnets

**Ni plating:** very popular for sintered neo. In order to have better protection, **Ni-Cu-Ni plating** is commonly applied.

**Aluminum IVD:** for applications with tight tolerance

**Epoxy coating:** Very common for bonded neo magnets.

Best choice for outdoor applications or very humid environment.