

# EIC Dual-Radiator RICH

## EPIC PID Review

Contalbrigo Marco – INFN Ferrara

1. Title
  2. dRICH Collaboration
  3. EIC forward RICH
  4. dRICH Baseline Design
  5. dRICH Organization
  6. dRICH Layout
  7. dRICH Gas Radiator
  8. dRICH Aerogel Radiator
  9. dRICH Mirrors
  10. EPIC Environment
  11. dRICH Photo-detector
  12. dRICH Readout Scheme
  13. dRICH Services
  14. dRICH Simulation: Sensors Model
  15. dRICH Simulation: Aerogel Model
  16. dRICH Simulation: Resolution
  17. dRICH Simulation: Momentum Reach
  18. R&D: Status
  19. R&D: Highlight
  20. R&D: Milestones
  21. dRICH Construction Schedule
  22. Optimization & Risk Mitigation
  23. Environment, Safety & Health
  24. Quality Assurance
  25. Calibration & Commissioning
  26. Executive Summary
- Charge 1  
Charge 2  
Charge 3  
Charge 6

Compact cost-effective solution for particle identification in the high-energy endcap at EIC

**dRICH**



BA, BO, CS, CT, FE ,  
GE, LNF, LNS, RM2,  
SA, TO, TS



**NISER**



**EPIC**

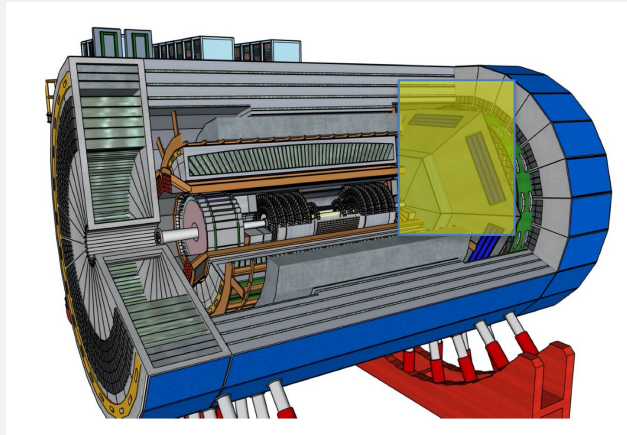

**EIC RICH Consortium**



....

Background Expertise:

CLAS12 RICH

COMPASS RICH

ALICE HMPID

DARKSIDE

ALCOR

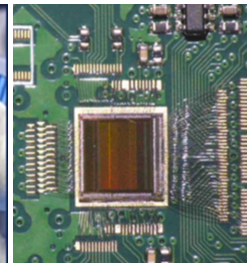
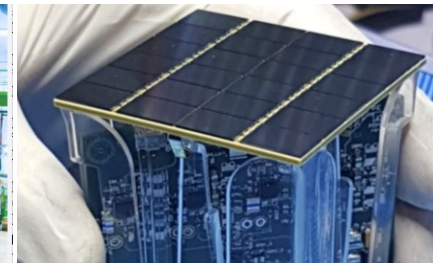
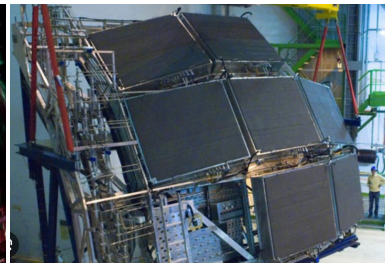
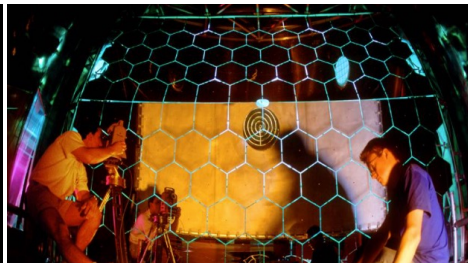
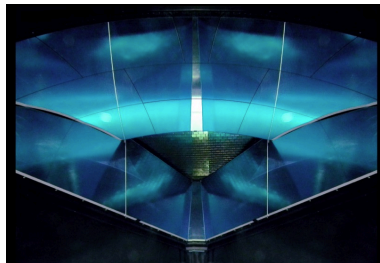

Forward particle detection

Hadron ID in the extended 3-50 GeV/c interval

Support electron ID up to 15 GeV/c

$\eta$	Nomenclature	Electrons and Photons			$\pi/K/p$	
		Resolution $\sigma_E/E$	PID	Min E Photon	p-Range	Separation
1.0 to 1.5	Forward Detectors	2%/E ⊕ (4*-12)%/√E ⊕ 2%	3σ e/π up to 15 GeV/c	50 MeV	≤ 50 GeV/c	≥ 3σ
1.5 to 2.0						
2.0 to 2.5						
2.5 to 3.0						
3.0 to 3.5						

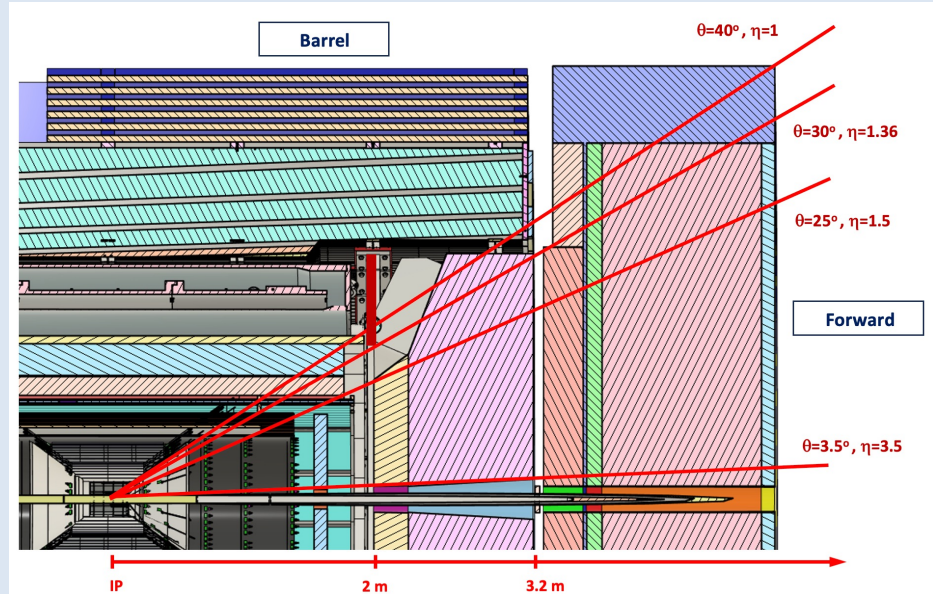
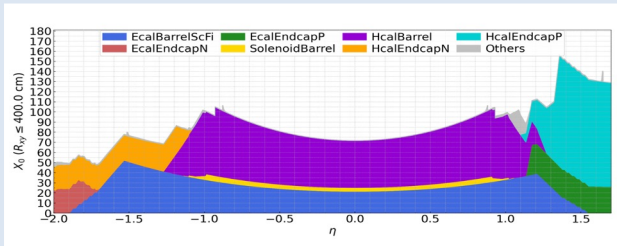
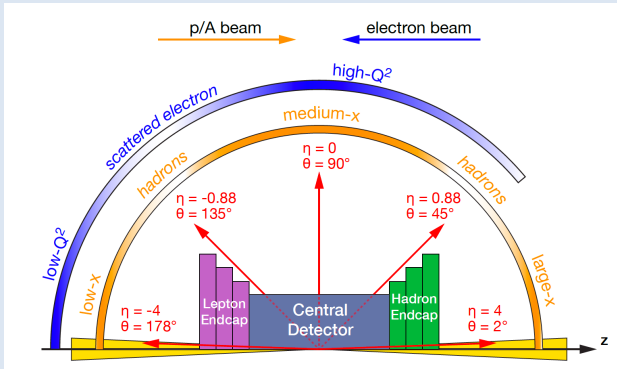

Essential for semi-inclusive physics  
due to absence of kinematics constraints at event-level

## Main features

cover wide momentum range 3 - 50 GeV/c  
 work in high ( $\sim 1\text{T}$ ) magnetic field  
 fit in a quite limited (for a gas RICH) space

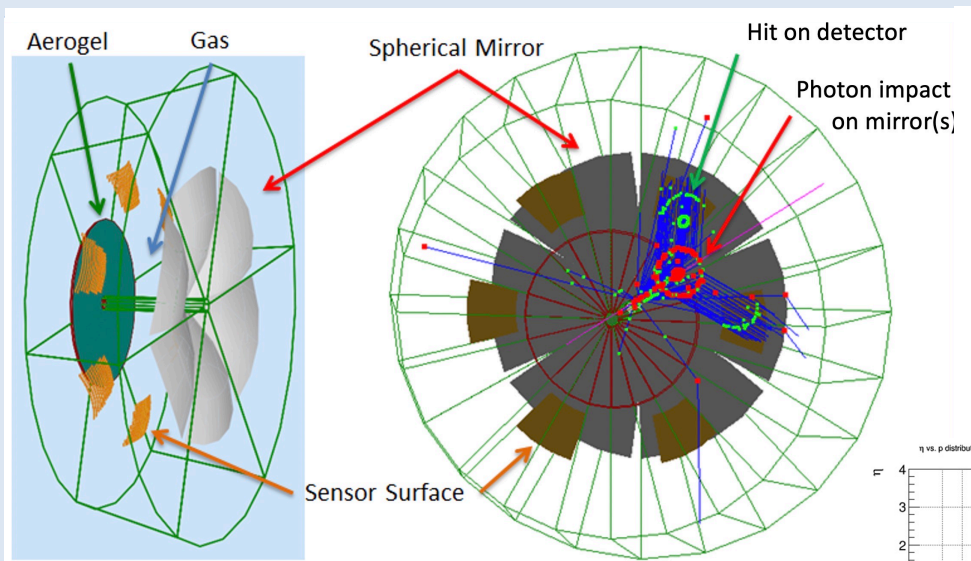

## dRICH: cost-effective compact solution

Radiators: Aerogel ( $n_{\text{AERO}} \sim 1.02$ ) + Gas ( $n_{\text{C}_2\text{F}_6} \sim 1.0008$ )

Detector:  $0.5 \text{ m}^2/\text{sector}$ ,  $3 \times 3 \text{ mm}^2$  pixel  $\rightarrow$  SiPM option

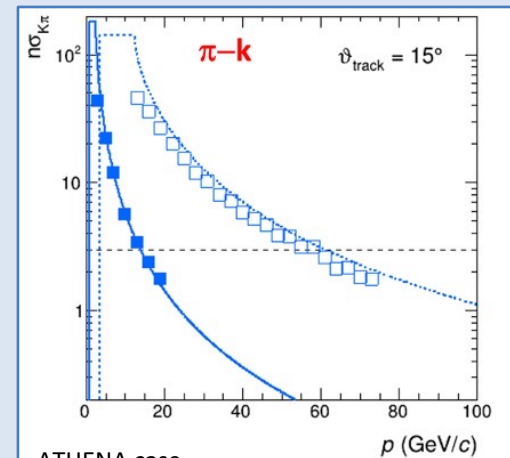
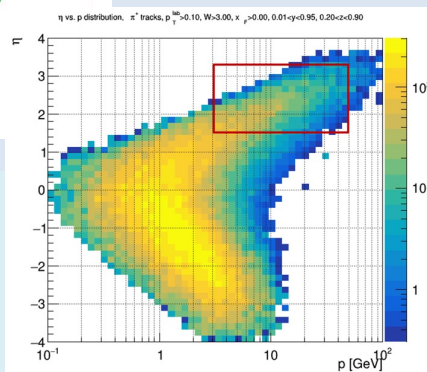

ATHENA case

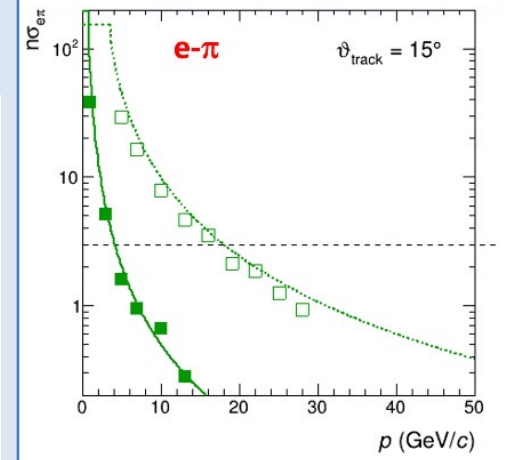

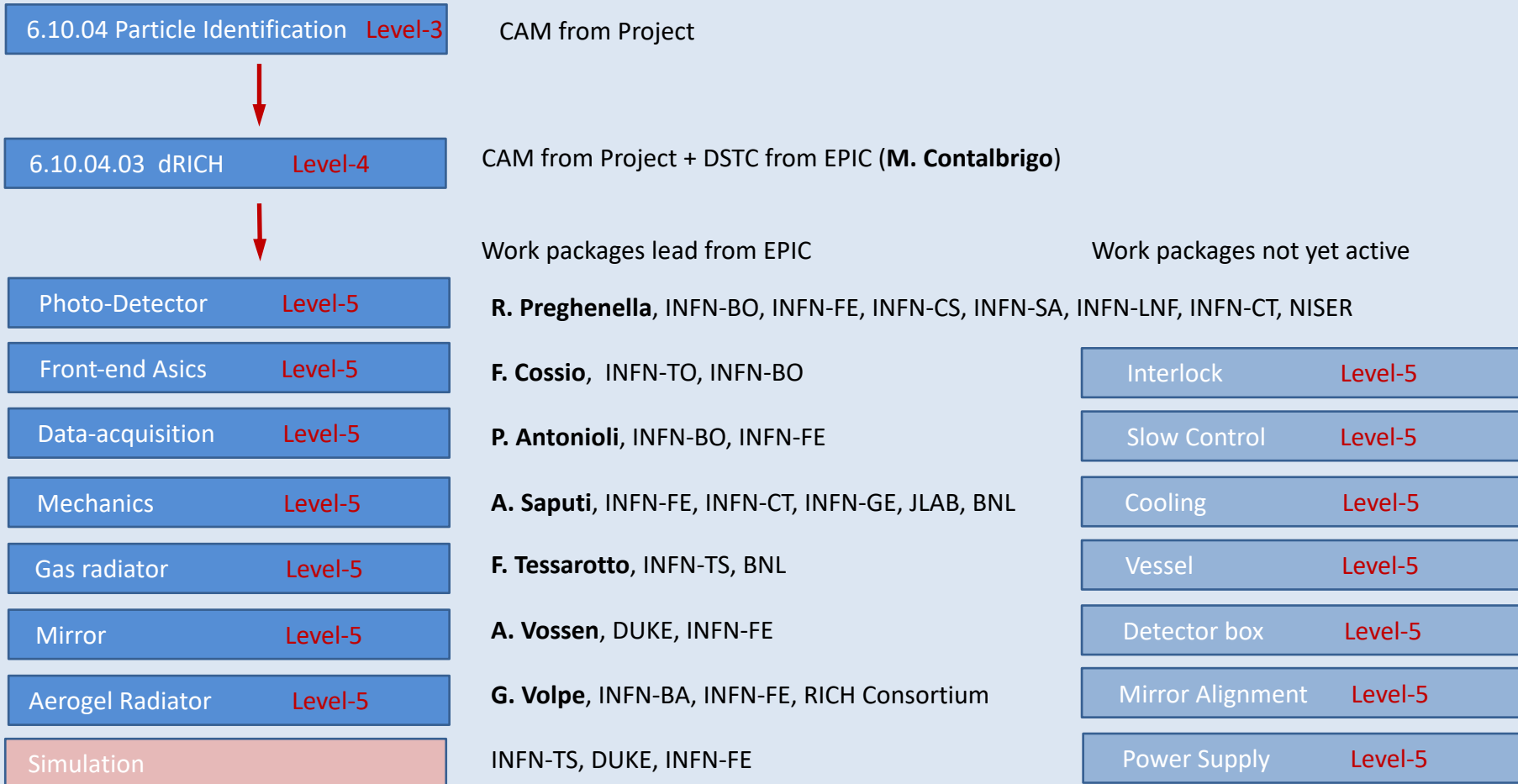

# dRICH Layout

Simplified representation

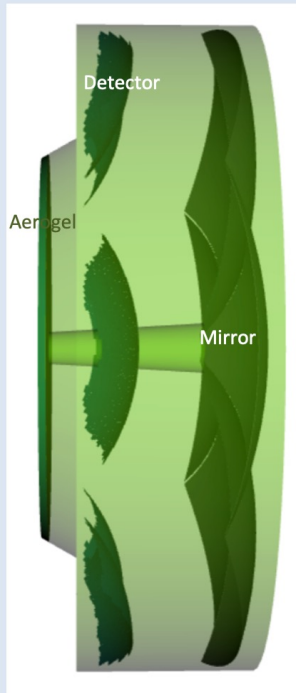

3D mechanical model

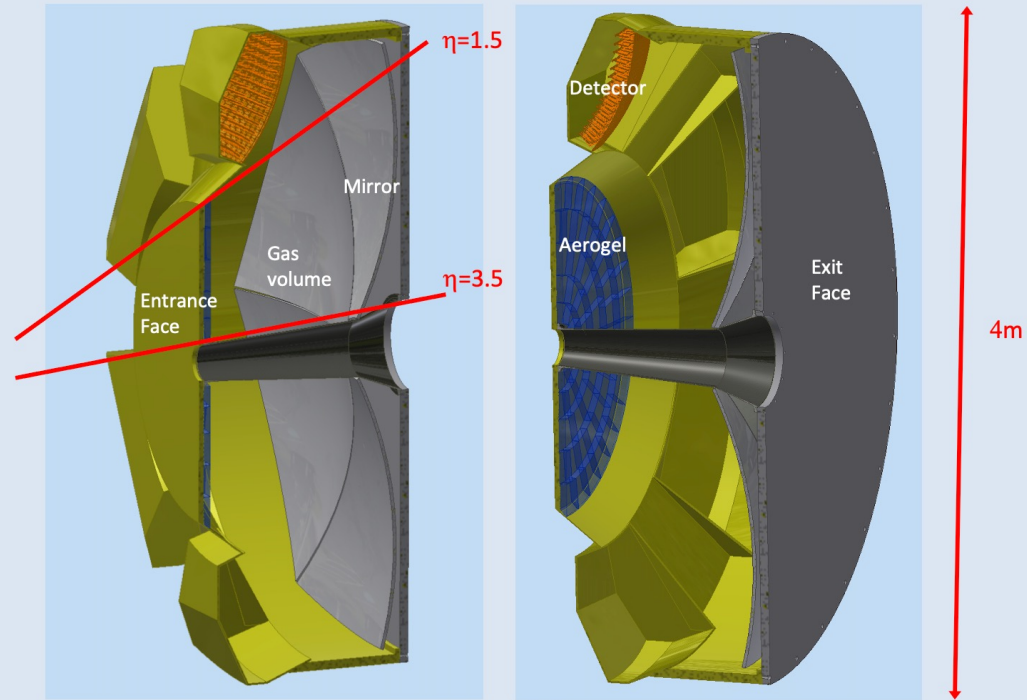

**Windows:** sandwich panel made of two  $\sim 1$  mm carbon fiber reinforced epoxy skins separated by 30 mm PMI foam or Al honeycomb ( $\sim 1\% X_0$ )

**Shells:** 3 mm (inner tube) to 8 mm (outer tube) thick carbon fiber epoxy composite ( $\sim 4\% X_0$ )

Skins formed with two layers of balanced weave laminate with fibers at  $0^\circ/90^\circ$  and  $\pm 45^\circ$  for uniform stiffness

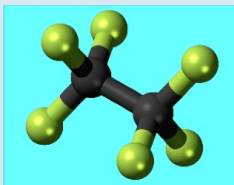

## 50 GeV/c pions and kaons shot at eta 2.5

Gas	Npe(pi /K)	Th_pi	Th_K	Sig_pi	Sig_K	N_Sig
C2F6	16.03/ 14.94	36.8	35.67	0.32	0.33	3.5
C4F10	24.8/2 3.8	48.63	47.8	0.29	0.30	2.8



## Chromaticity

$$\Delta\theta = \theta_{\check{c}}(\lambda=300\text{nm}) - \theta_{\check{c}}(\lambda=600\text{nm})$$

$$\rho = \Delta\theta / \theta_{\check{c}}(\lambda=300\text{nm})$$

$$\rho_{\text{C2F6}} = 1.8\% ;$$

$$\rho_{\text{C4F10}} = 2.4\% ;$$

Assume dRICH volume ~ 20 m<sup>3</sup>

C<sub>2</sub>F<sub>6</sub> density 5.73 Kg/m<sup>3</sup> → 114 kg

Initial minimal quantity ~ 200 kg

~ 500 kg could be enough for 10 yr of operation

Initial survey:

Several distributors contacted:  
availability confirmed by two:

- SIAD S.p.A.
- Resonac Europe GmbH

Yearly leaks are difficult to estimate:

- Filling and recovery operations 6%
- Filtering and maintenance 3%
- Leaks 10%
- Sampling, analysis, etc. 2%

30 kg /yr emission → 300 tCO<sub>2</sub> /yr

comparable to one intercontinental flight /yr

CERN new gas systems qualification standard:

Target Leak flow at reference conditions	<1*10 <sup>-3</sup> STD cc/s
---	------------------------------

New standards should reduce significantly the losses and environmental impact

## Aerogel Factory (BELLE-II)

Initial evaluation & Reproducibility on small samples in synergy with ALICE

### Transmittance & Transflectance

Nominal 2021 and measured 2021

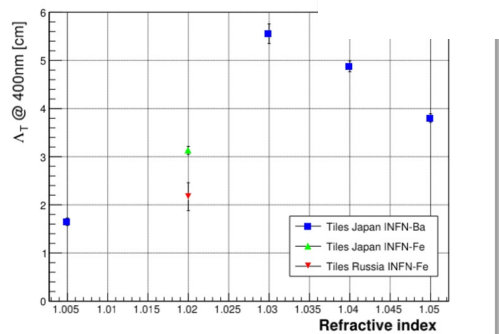
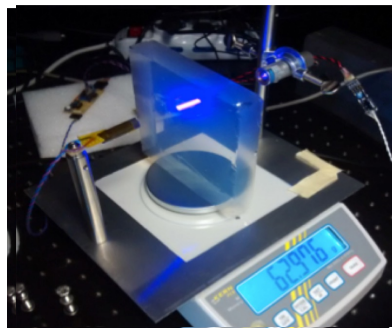
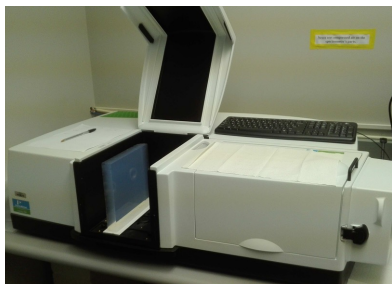
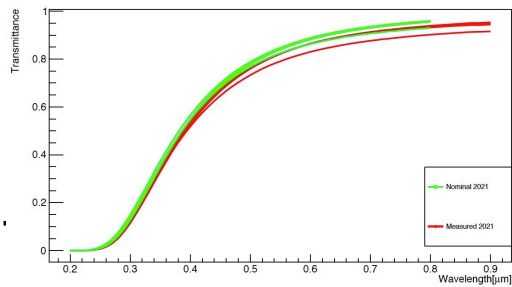

Density & refractive index

### Laser spot bradening: Y profile

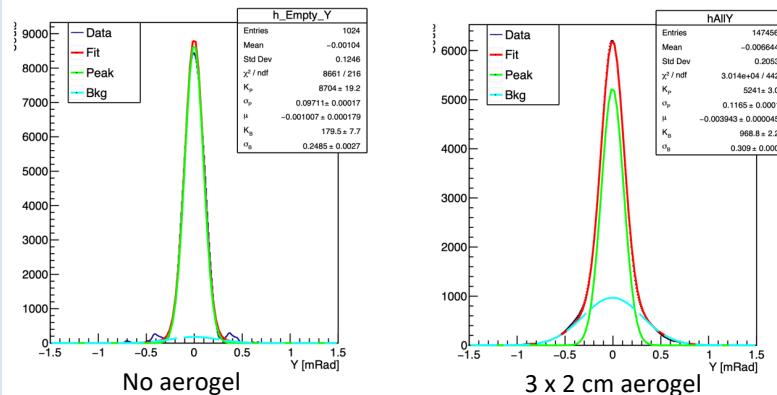

### Touch Probe: planarity and thickness

10x10x2 cm<sup>3</sup> tile (from ALICE)

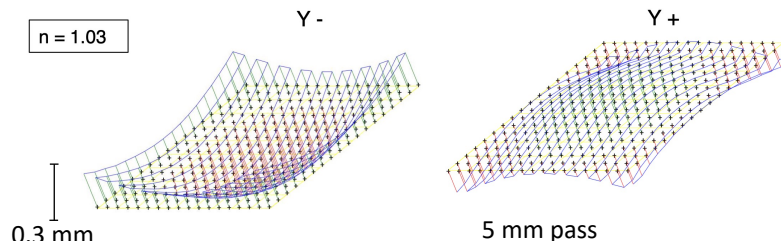



**CMA Carbon fiber mirrors** (HERMES, AMS, LHCb, CLAS12)

cost-effective light & stiff solution:

roughness driven by mandrel 1-2 nm rms

surface accuracy better than 0.2 mrad

radius reproducibility better than 1 %

Surface Quality

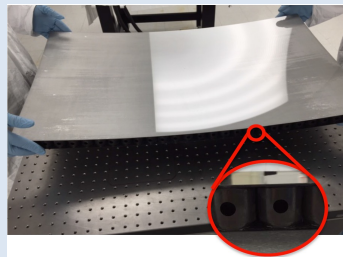
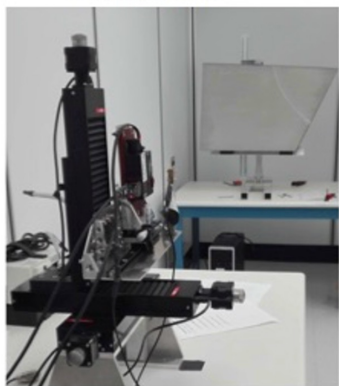

Shack-Hartmann sensor  
Mirror aberrations

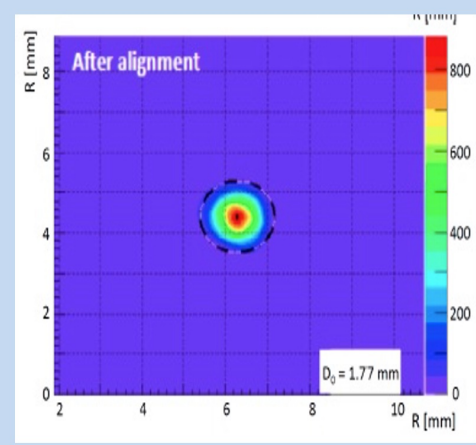
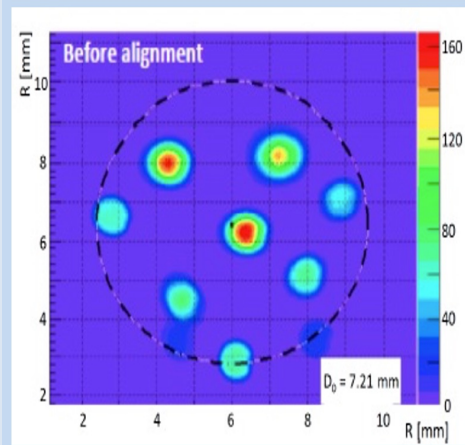
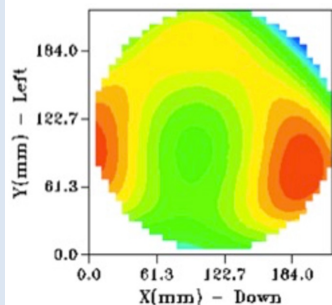

CLAS12 RICH QA laboratory  
@ JLab being refurbished

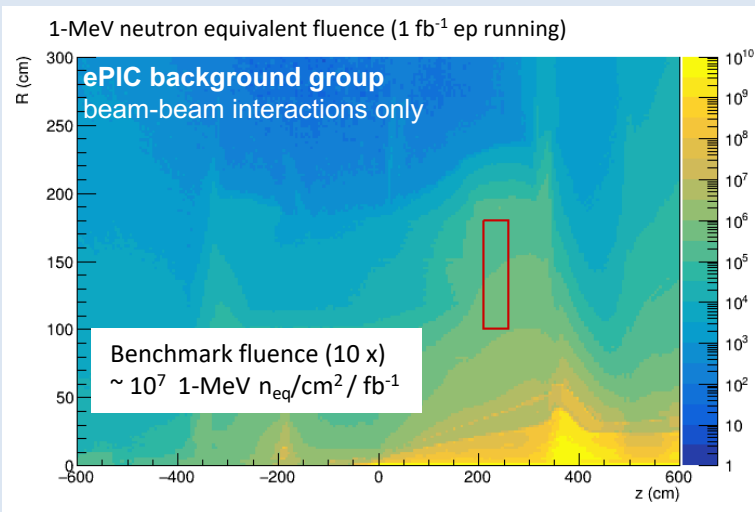
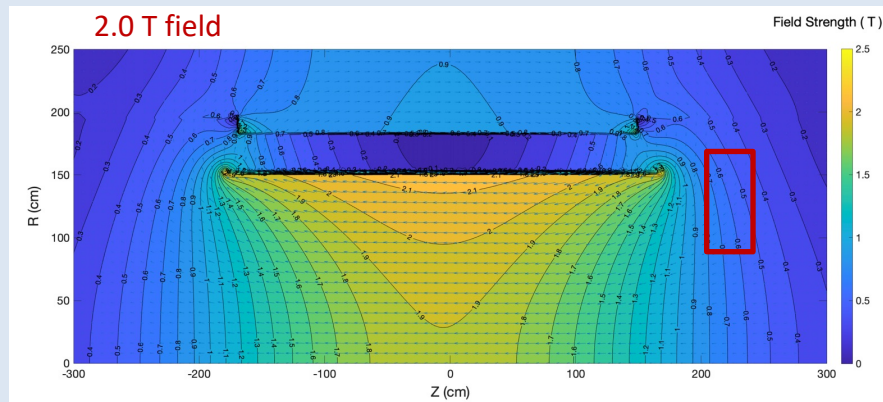
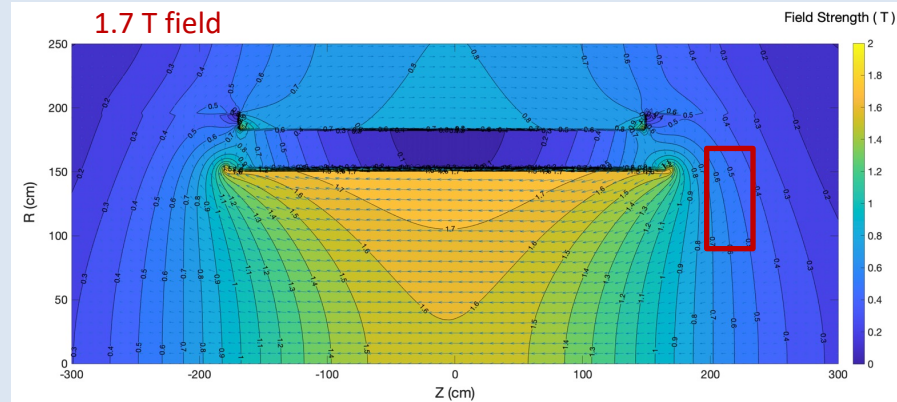
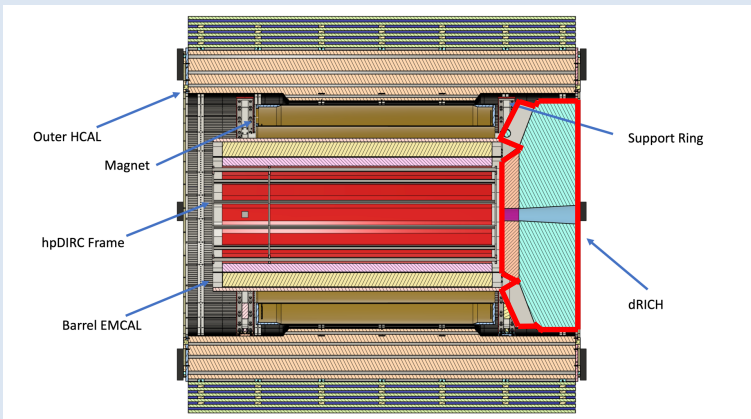

Strong (~ 0.7 T) magnetic field, not uniform  
 Moderate radiation level (~ 10<sup>10</sup> n<sub>eq</sub>/cm<sup>2</sup> after 1000 fb<sup>-1</sup>)

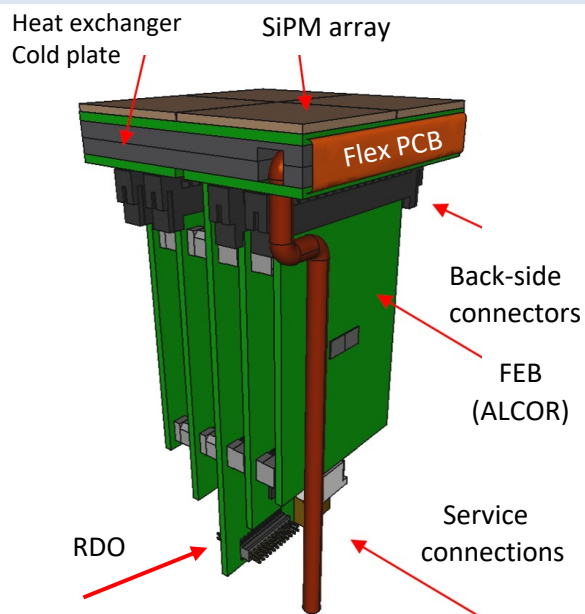

## Photon Detector Unit (PDU):

Compact to minimize space

4x Hamamatsu S13361-3050HS SiPM arrays

4x Front-End Boards (FEB)

4x ALCOR chip (ToT discrimination)

1x Read-Out Board (RDO)

1x Cooling plate (< -30 C)

Active area is shaped to resemble the focal surface and best exploits the focalization

## Detector box:

Shaped to fit the space

Quartz window

Cooling for sensors and electronics

Power distributing patch panel

Heat insulation

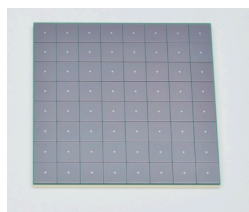
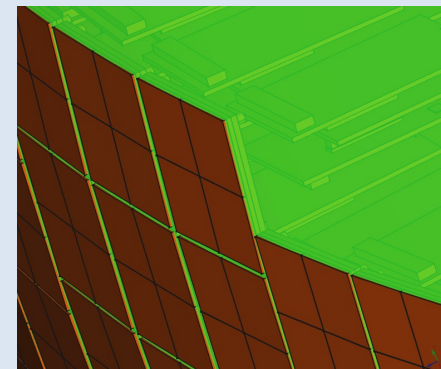

SiPM array

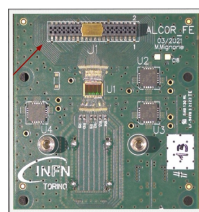

ALCOR chip

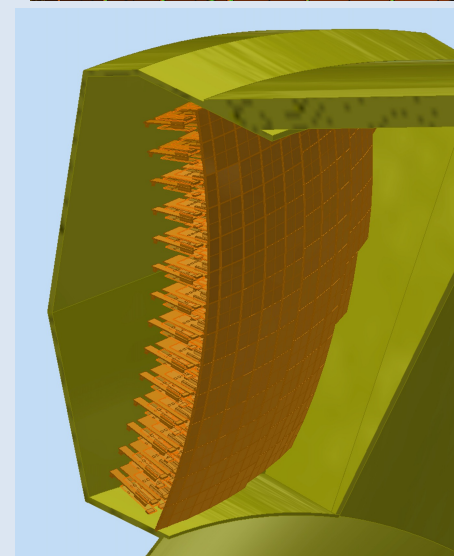

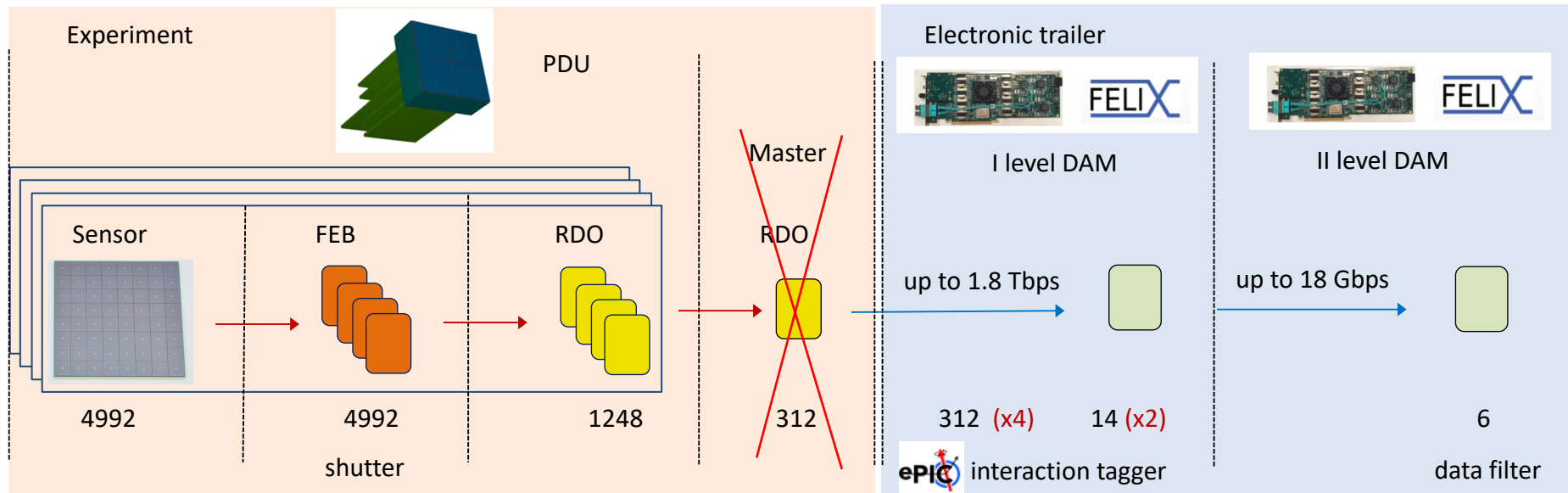

**Reduce complexity** at the detector level (spare space, custom boards, FPGA/SEU)

**Maximise modularity** (detector shaping) and **capability** (data stream)

DAM Hierarchy: Maximum data rate capability till DAM-L1

Big data reduction at DAM-L1 with external input (2  $\mu$ s latency interaction tagger)

DAM-L2 data aggregation per sector allows for effective data-reduction algorithms

DAM-L1 might be eventually stored in the experimental Hall (rack enclosure)

Commercial Examples:

Power supply



Cooling plants



General & Temperature Control																			
Temperature range	-55...250 °C																		
Temperature stability	±0.01 K																		
Heating / cooling capacity																			
Heating capacity	6 kW																		
Cooling capacity	<table border="1"> <tr> <td>250</td> <td>200</td> <td>100</td> <td>20</td> <td>0</td> <td>-20</td> <td>-40</td> <td>-50</td> <td>°C</td> </tr> <tr> <td>6</td> <td>6</td> <td>6</td> <td>6</td> <td>6</td> <td>4.2</td> <td>1.5</td> <td>0.65</td> <td>kW</td> </tr> </table>	250	200	100	20	0	-20	-40	-50	°C	6	6	6	6	6	4.2	1.5	0.65	kW
250	200	100	20	0	-20	-40	-50	°C											
6	6	6	6	6	4.2	1.5	0.65	kW											

Existing systems & standards:

COMPASS  
C<sub>4</sub>F<sub>10</sub> recirculating and purging system

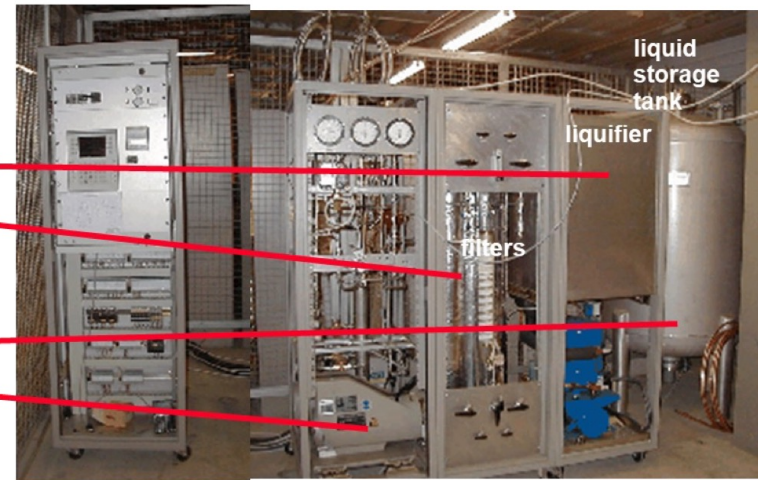
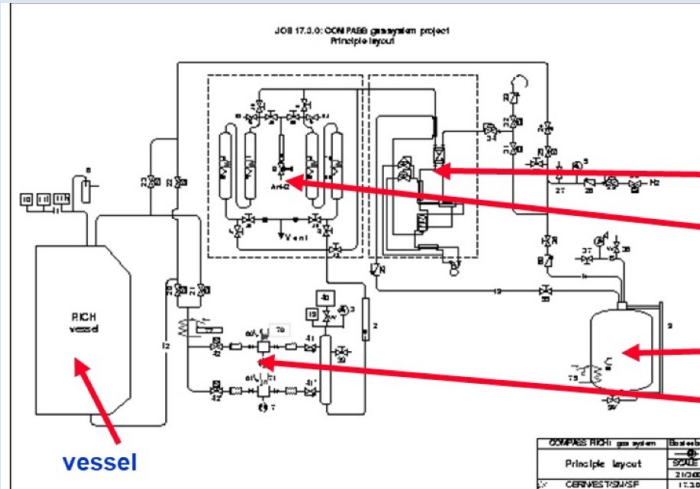



Comparison DATA vs MC model

DATA: Aerogel Factory samples

MC: EPIC parameterizaion

Chromatic dispersion  
(major expected contribution to resolution)

Data from dRICH prototype

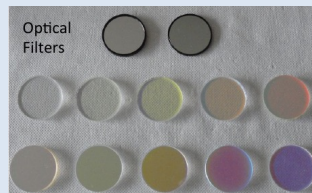

Refractive index

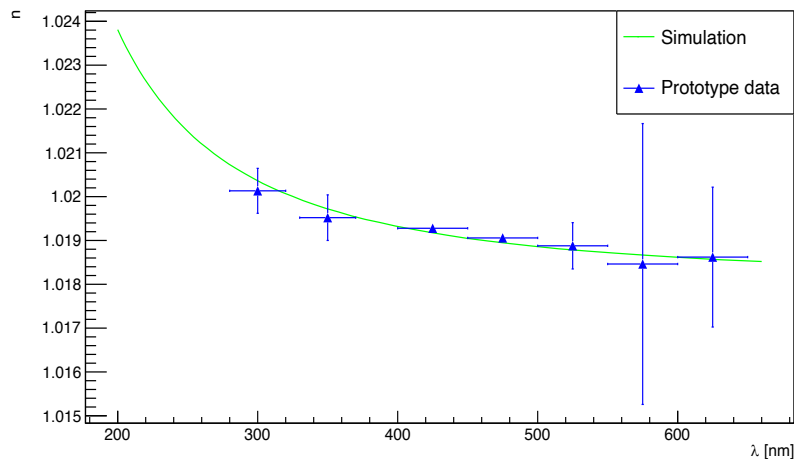

Absorption length

Data from INFN characterization

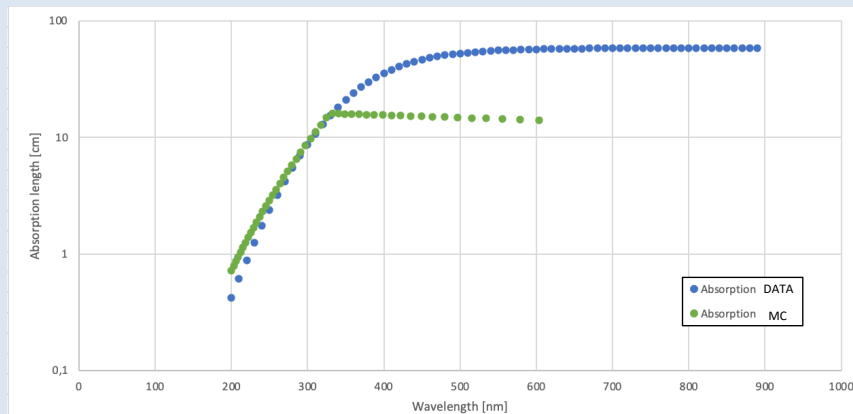

Scattering length

Data from INFN characterization

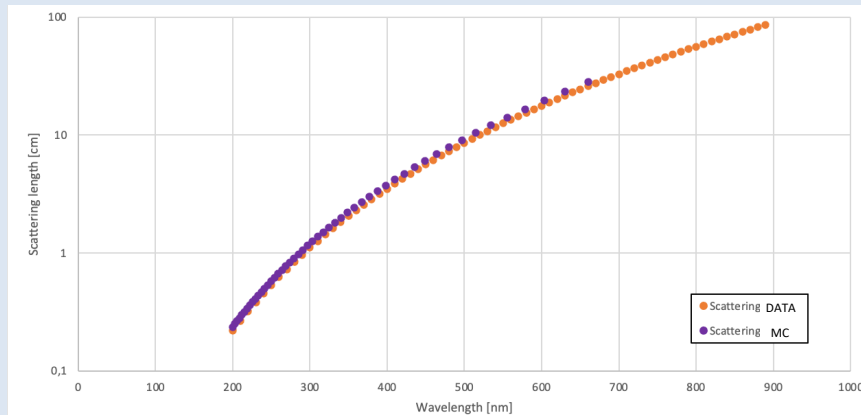

Preliminary optimization of the dRICH optics inside EPIC

Magnetic field and track resolution accounted for, results averaged over azimuthal angle ( $\phi$ )

With single mirror, best focalization in the most demanding 2.5-3.5 pseudo-rapidity range to get  $\sim 0.3$  mrad resolution

$> 3\sigma$  separation in the wanted momentum range (i.e. at maximum momentum)

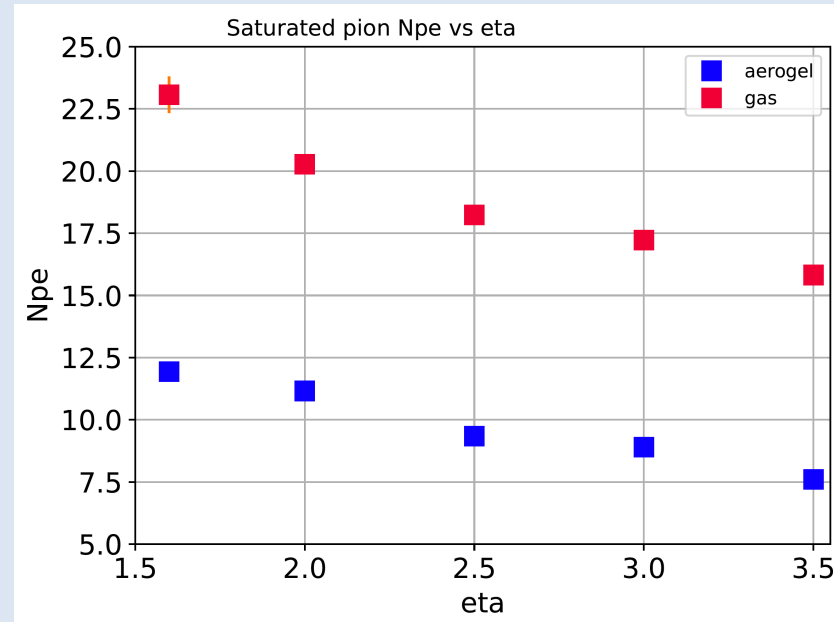
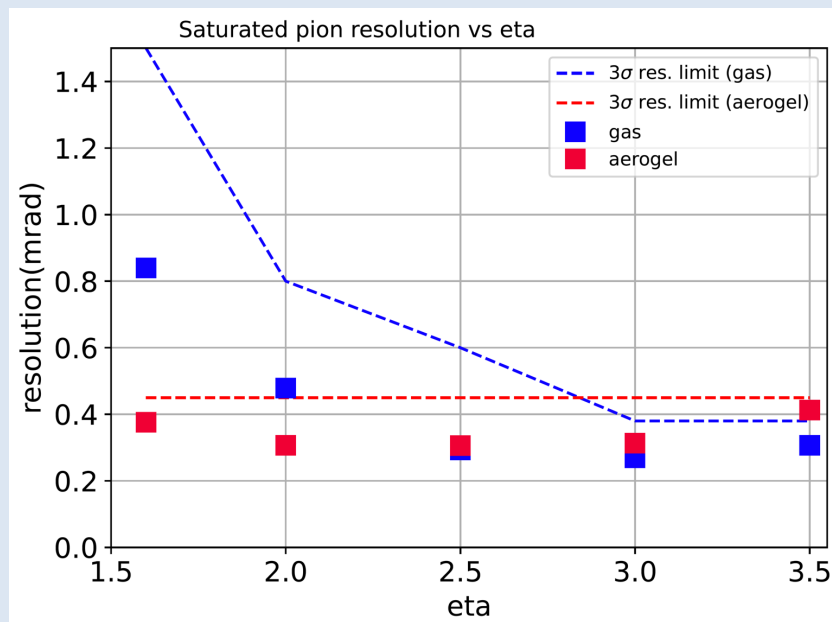



## Momentum reach

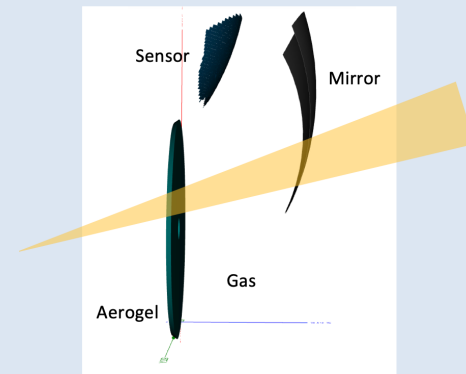
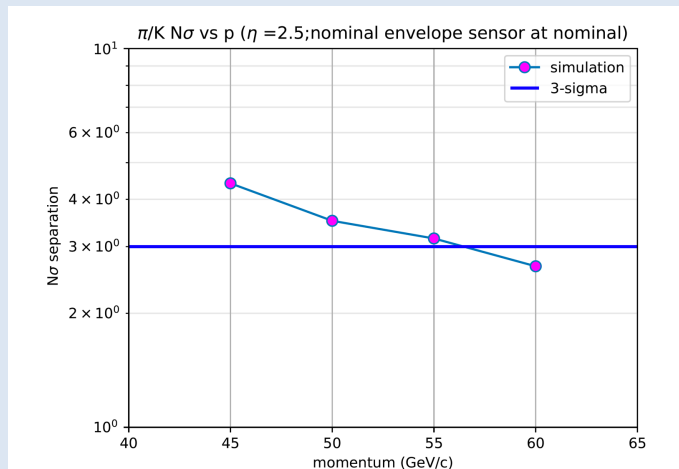

## Interplay between radiators

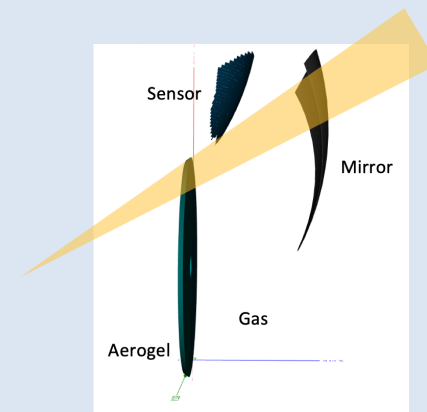
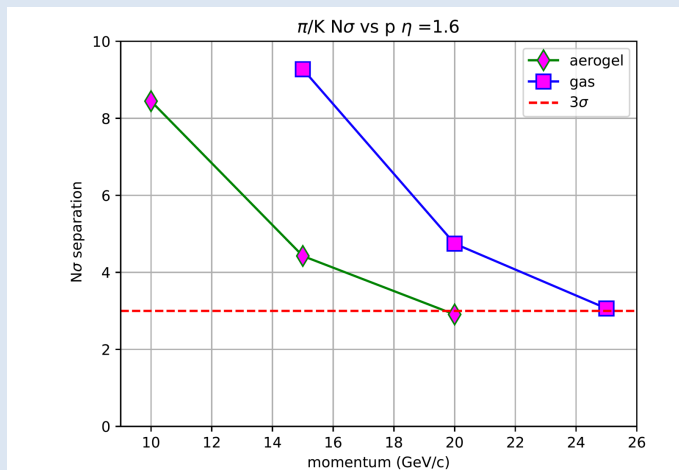

Operative prototype commissioned. Double ring imaging achieved. Performance in line with expectations except for aerogel single-photon angular resolution (worse by a factor  $\sim 1.5$ )

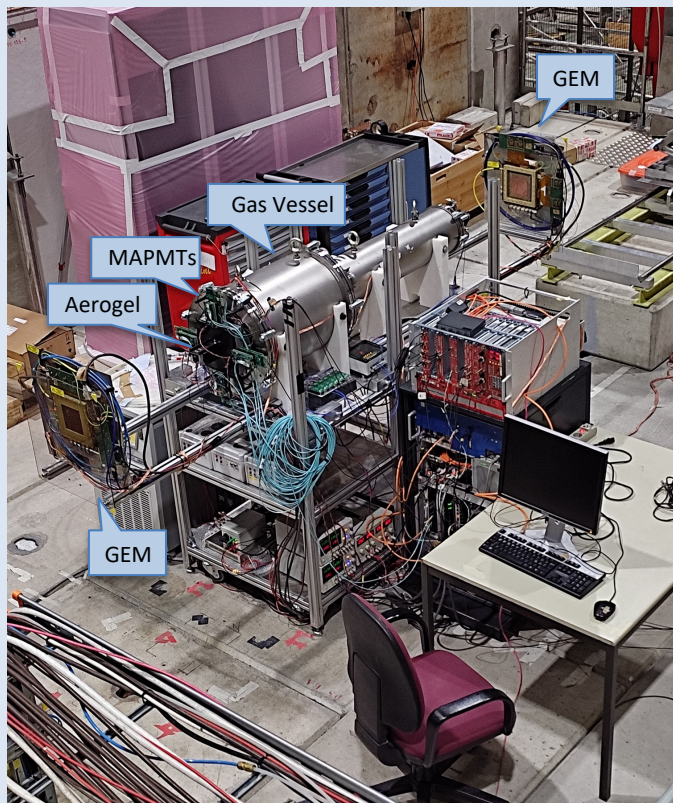

Reference readout from CLAS12 RICH:  
H13700 MA-PMTs + ALCOR3 ToT chip

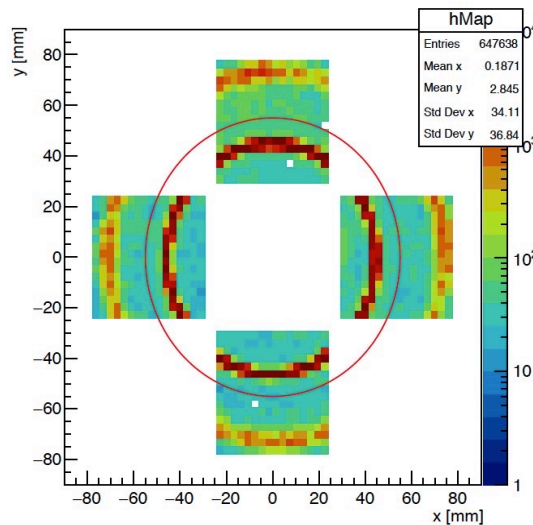

Gas ring coverage: 60%  
Aerogel ring coverage: 40 %

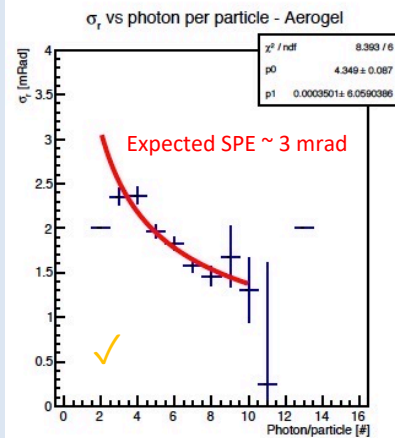
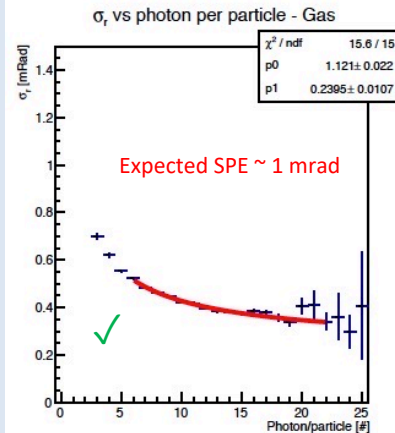

Optics at variance with respect EIC

**Realization of a suitable detector plane for the dRICH prototype (23/10):** Design ready, procurement aligned to 2023 test-beam campaign.

Hamamatsu S13361-3050



8x8 array  
50  $\mu\text{m}$  cell  
Excellent fill factor  
Best DCR

S14160 alternative

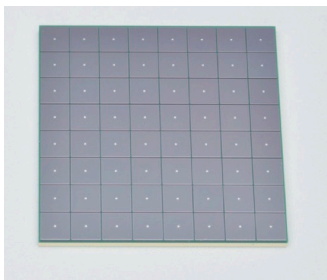

**MPPC arrays** selected with irradiation campaign

**Front-end re-design** completed

**ALCOR v2 (better dynamic range and rate)**

ToT architecture, streaming mode ready

- 50 ps time bin
- 500 kHz rate per channel
- cryogenic compatible

ALCOR chip



Multi-wafer run done

Version2:  
32 channels  
Extended dynamic range  
Improved digital time

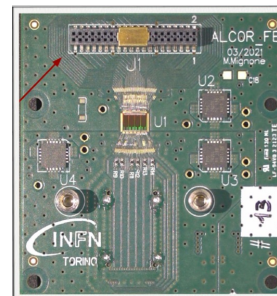

Cooling plate

Peltier cells

Annealing circuitry

**Integrated Cooling/ In-situ annealing**

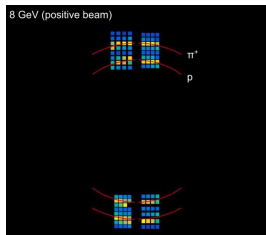
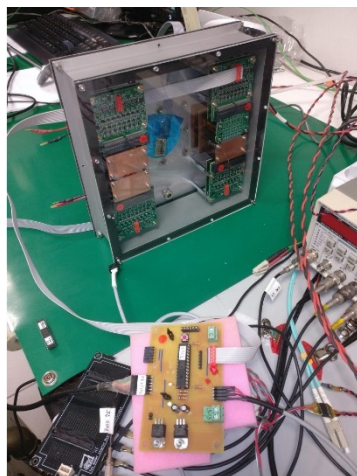

New EIC-driven readout unit

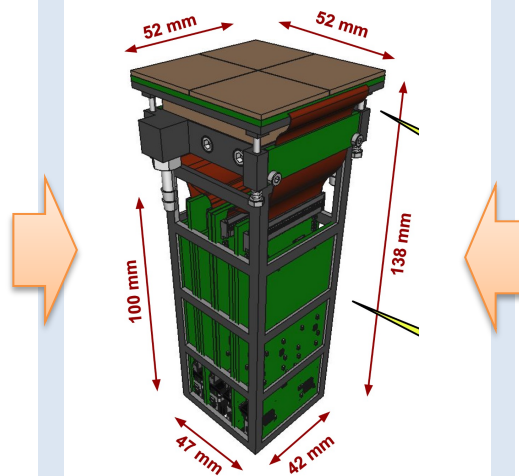

**Streaming readout**



2023:  
1 RDO per chip

2024:  
1 RDO per PDU

Development  
Kit KC705

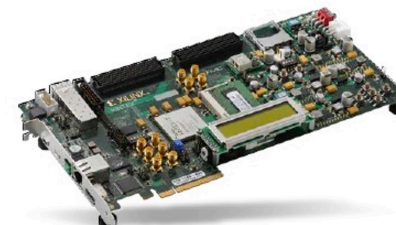

## 2023: EIC-driven detector plane

- ✓ Initial characterization of realistic aerogel and mirror components (23/04); ➡ Slide 8
- ✓ Projected performance of the baseline detector as integrated into EPIC (23/06); ➡ Slide 16
- ✓ Assessment of the dRICH prototype performance with the EIC-driven detection plane (23/10). ➡ Slide 19

**Test beam planned in August and October 2023**

## 2024: Real-scale prototype for TDR (1 sector)

Mechanical structure

Realistic optics (off-axis)

ALCOR64 FEB + RDO

Aerogel and mirror demonstrator

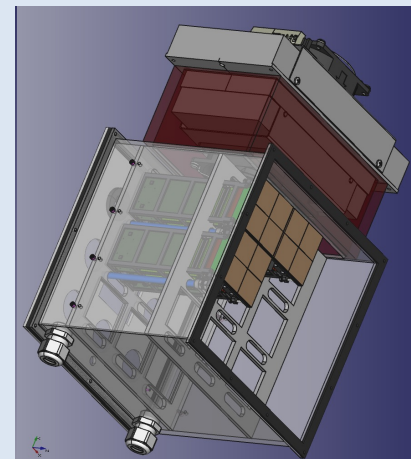
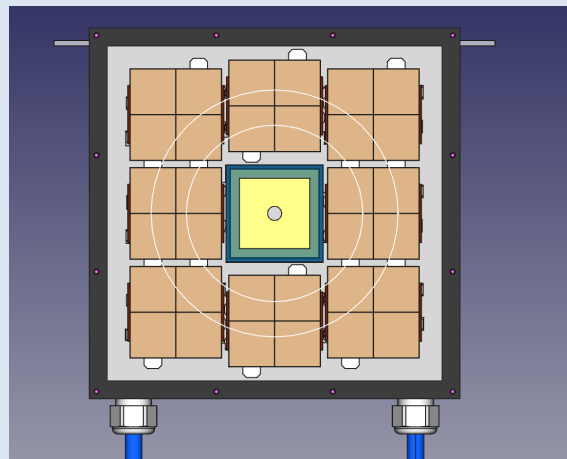

New EIC-driven readout unit

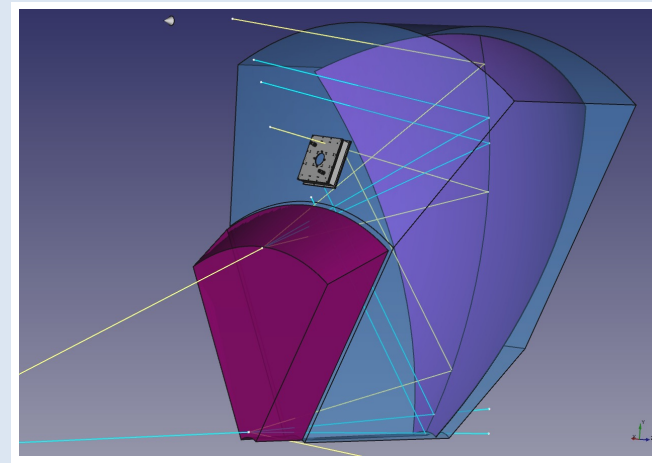
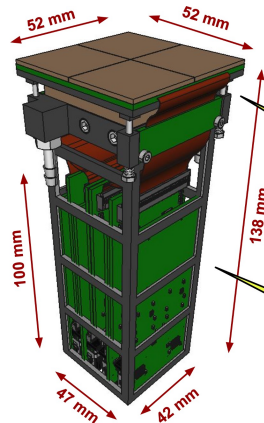

# dRICH Construction Schedule

## EIC - Working File

Data Date: 02-Jan-20

## EIC - Activities with Gantt

TASK filter: WBS Path 06.10.04.02.

WBS Path	Activity ID	Activity Name	Original Duration	Start	Finish	Gantt Chart (2022-2028)											
<b>Project: ECE06 EIC - Working File</b>			1797	01-Oct-21	12-Dec-28	[Gantt bars for project summary]											
<b>WBS: ECE06.10 EIC Detector</b>			1797	01-Oct-21	12-Dec-28	[Gantt bars for WBS summary]											
<b>WBS: ECE06.10.04 Particle Identification (PID)</b>			1797	01-Oct-21	12-Dec-28	[Gantt bars for WBS summary]											
<b>WBS: ECE06.10.04.02 Dual Ring Imaging Cherenkov Detector (dRICH)</b>			1797	01-Oct-21	12-Dec-28	[Gantt bars for WBS summary]											
10.04.02	EIPICH_L_FY22	6.10.04.02 - EIPICH - FY22 Labor Actuals	250	01-Oct-21	30-Sep-22	[Gantt bar]											
10.04.02	E1004_20000	PDR - Preliminary Design, Beam Test & Assessment (dRICH)	110	03-Oct-22	15-Mar-23	[Gantt bar]											
10.04.02	E1004_20010	Prototyping (dRICH)	313	03-Oct-22	05-Jan-24	[Gantt bar]											
10.04.02	E1004_20020	Specifications 100% Defined for 3A Procurement (dRICH)	0		31-Oct-22	[Milestone]											
10.04.02	E1004_20030	PDR - Preliminary Design Complete (dRICH)	0		15-Mar-23	[Milestone]											
10.04.02	E1004_20040	FDR - Final Design & Finalize dRICH Design with All Required Services (dRICH)	109	16-Mar-23	17-Aug-23	[Gantt bar]											

SiPM may require longer engineering to reach the best performance (e.g. match temperature treatments)

10.04.02	E1004_20580	AWARD: Photo Sensors (dRICH)	1	02-Oct-23	03-Oct-23	[Gantt bar]											
10.04.02	E1004_20660	AWARD: SiPMs Cooling System (dRICH)	1	02-Oct-23	03-Oct-23	[Gantt bar]											
10.04.02	E1004_20730	AWARD: Mirror Alignment System (dRICH)	1	02-Oct-23	03-Oct-23	[Gantt bar]											
10.04.02	E1004_20800	AWARD: Cooling System (dRICH)	1	02-Oct-23	03-Oct-23	[Gantt bar]											
10.04.02	E1004_20590	VENDOR EFFORT: Photo Sensors (dRICH)	360	03-Oct-23	17-Mar-25	[Gantt bar]											
10.04.02	E1004_20080	Write SiPMs Requisition (dRICH)	0		31-Dec-24	[Milestone]											
10.04.02	E1004_20090	SiPMs Procurement Effort with Technical Support (dRICH)	410	02-Jan-25	19-Aug-26	[Gantt bar]											
10.04.02	E1004_20630	RCV: Photo Sensors (dRICH)	1	17-Mar-25	18-Mar-25	[Gantt bar]											

Aerogel may require longer engineering to reach the best performance (e.g. mass production efficiency)

10.04.02	E1004_20530	AWARD: Aerogel (dRICH)	1	02-May-25	02-May-25	[Gantt bar]											
10.04.02	E1004_20320	Test & Q.C. First Article Mirror (Includes Developing Test Plan) (dRICH)	115	05-May-25	16-Oct-25	[Gantt bar]											
10.04.02	E1004_20490	VENDOR EFFORT: C2F6 Gas Recovery System (dRICH)	180	05-May-25	23-Jan-26	[Gantt bar]											
10.04.02	E1004_20540	VENDOR EFFORT: Aerogel (dRICH)	500	05-May-25	04-May-27	[Gantt bar]											

Readiness planned 2 years before installation might result in a too aggressive schedule (see above)

10.04.02	E1004_20260	Ready for Installation (dRICH) (BNL)	0		09-May-28	[Milestone]											
10.04.02	E1004_20140	SiPMT & SiPMT Test, Final Acceptance (dRICH)	20	13-Nov-28	12-Dec-28	[Gantt bar]											
10.04.02	E1004_20130	SiPMT & SiPMT PCB Board Vendor Delivery (dRICH)	1	12-Dec-28	12-Dec-28	[Gantt bar]											
10.04.02	E1004_20150	Ready for Installation (dRICH)	0		12-Dec-28	[Milestone]											

Component	Baseline	Optimization	Possible improvement
SiPM	Hamamatsu H13361-3050HS	75 $\mu\text{m}$ cell FBK sensor	Larger PDE Better time resolution
Aerogel radiator	Aerogel Factory n=1.02	Refractive index Tile dimensions Tsinghua aerogel	Increase photon yield Reduce edge effects Risk reduction for single vendor
Gas radiator	SIAD C <sub>2</sub> F <sub>6</sub>	Gas mixture Early procurement	Reduced environment impact (global warming) Limit dependence on market & regulations
Mechanics	Tecnavan Carbon fiber composite	Al composite	Cost reduction
Mirrors	CMA Carbon fiber composite	Mold material Different core structure Tessellation	Better shape quality vs cost
Cooling	Al plate	Carbon foam plate	Reduce material budget

1 year typical  $C_2F_6$  losses would correspond to 1 intercontinental flight  $CO_2$  emission  
requires to minimize losses in the recirculating system

About 2-2.5 kW per detector box  
requires liquid cooling, air circulation + interlock

On-site annealing requires single-sensor temperature (optical) control

Low-T coolant circuit (down to -50 C) requires proper circuit and insulation

Thin transparent septa require delta-pressure control and safety diaphragm

- Aerogel:** Refractive index, dimensions, defects, transmittance  
organized within RICH Consortium (INFN-FE, INFN-BA, CERN, Temple)  
<https://docs.google.com/document/d/1YpN7gx85JjoQnoB9NbID61N9B1YhRGwBh2GIKZ2ST-0/edit>
- Mirror:** Dimensions, shape accuracy, radius, reflectivity  
JLab existing test laboratory with INFN-equipment, DUKE laboratory
- Sensors:** Electrical connections, quench resistor, I-V characteristics, DCR, relative PDE  
Test stations in Italy (INFN-BO, INFN-FE, INFN-CS)
- Front-end:** Electrical connections, time jitter, ToT characteristics  
Test stations in Italy (INFN-BO, INFN-TO)
- Gas:** Performance with prototype, transparency, contaminants  
CERN



## Detector response:

LED/laser system (sensor response and mirror alignment)

Dark count rate monitor

Single-photon time over threshold

## Time calibration:

Absolute time with respect bunch crossing and Forward TOF

Time intercalibration: photons hits from the same event

## Particle identification:

Control particle samples (identified by other systems)

Known meson decays ( $K_S$ ,  $\Lambda$ ,  $\Phi$ )

## Dual-radiator RICH is a cost-effective and compact solution for the forward PID at EPIC

**Baseline configuration** and technology has been identified to reach the EIC requirements

$3\sigma$  angular separation for forward hadrons up to 50 GeV/c momentum and up to 3.5 in pseudo-rapidity

**dRICH Collaboration** is setting up and an Executive Office has been engaged

**R&D** is on track to deliver the anticipated milestones towards TDR

Working on consolidating the baseline design with further optimization of the components

Need to integrate and validate all the progresses with a real-scale prototype prior of TDR

Aerogel and SiPM might need longer engineering (contingency) to reach the best performance