



Laser Ion Source (LDRD23-007)

High repetition rate Lithium Laser Ion Source for neutron beam production

Shunsuke Ikeda

12/20/2023



FY2023 Laboratory Directed Research & Development Program Type B

- Title: High repetition rate Li Laser Ion Source for neutron beam production
- Other Researchers and Engineers:
 - Takeshi Kaneshue, Masahiro Okamura, Chong-Jer Liaw, John Halinski
- Period: 10/2022 – 9/2024
- Goals:
 - Find optimum design of liquid lithium target and laser irradiation condition
 - Show feasibility of liquid target system for high repetition rate LIS,
- Applications:
 - 100 mA class Intense lithium beam driver
 - Compact neutron source

Laser ion source (LIS)

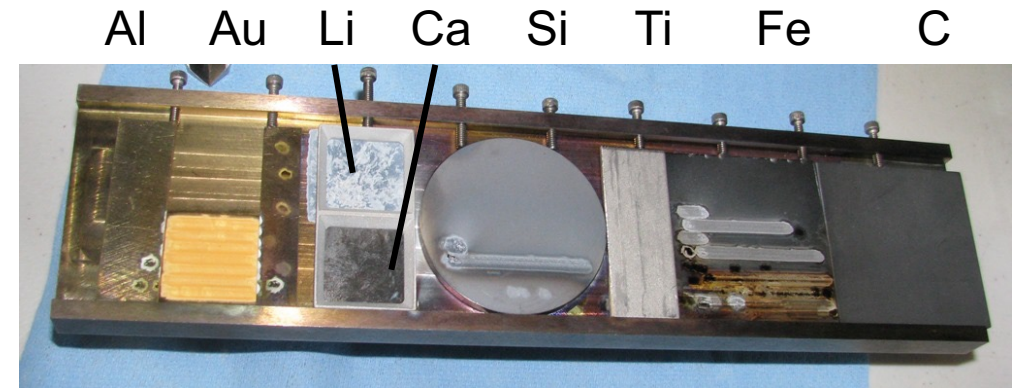
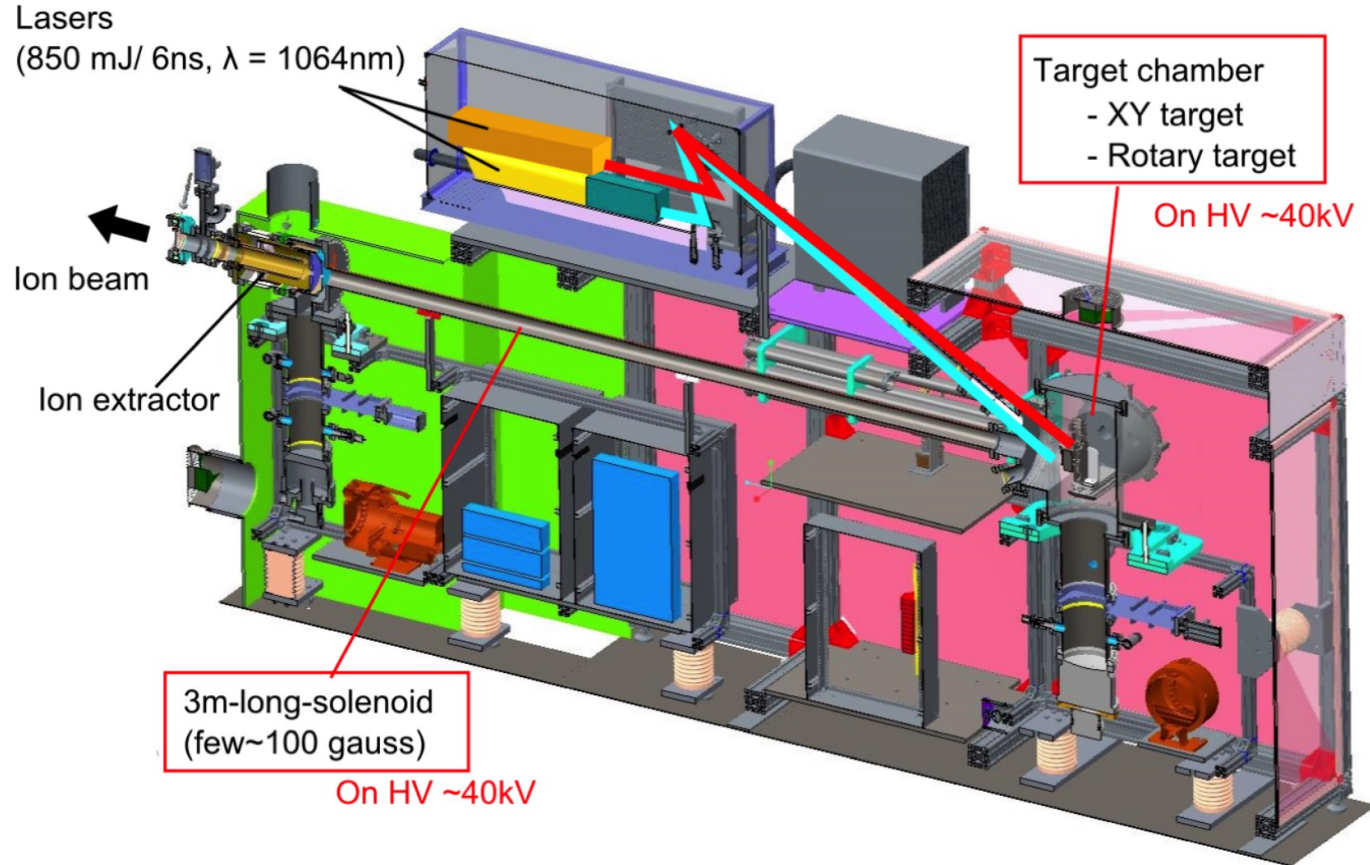

- Any types of ions can be produced from solid material
- Fast species switch (within seconds, 130 switches/day)

Intense pulsed beam with focused laser pulse

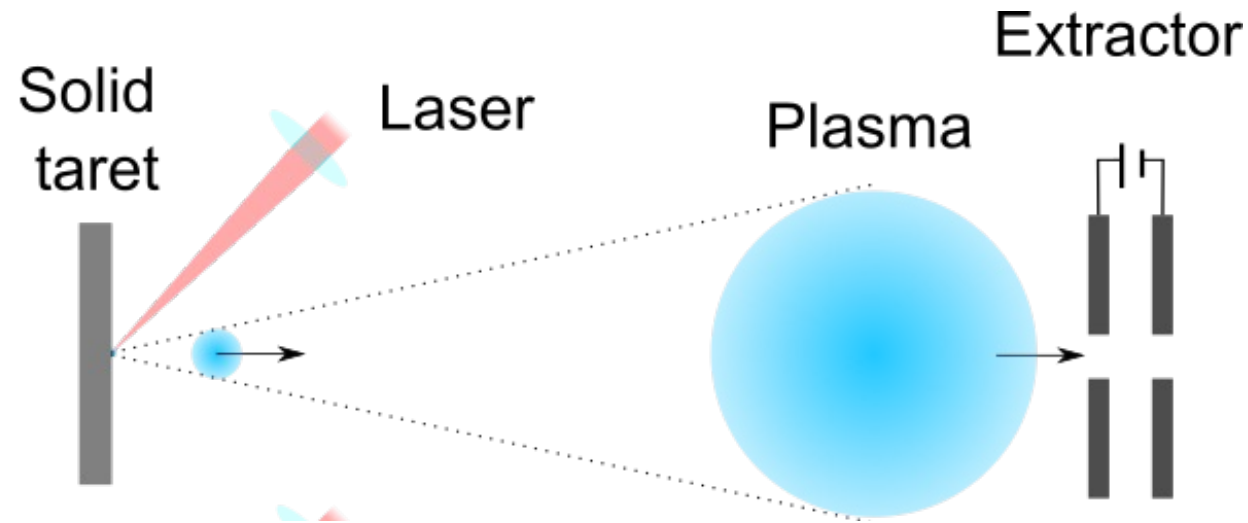

Plasma generation and heating

- Laser energy absorption in a skin layer of a solid target
- Laser energy absorption by electrons by Inverse Bremsstrahlung absorption
- Ionization of atoms and ions in plasma by electron impact

Advantage for ion source

- 1A class ion beam can be produced
- pulse width can be very short $< 1 \mu\text{s}$
- Ions are emitted from point source \rightarrow low emittance

Demand for compact accelerator driven neutron generator

Recently, as old reactors are retired, compact accelerator driven neutron generators are getting more desired.

Not nuclear facility

- Non-proliferation policies and difficulties of manufacturing fuel elements have prevented replacement of reactor

Low cost

- Spallation source is expensive and machine time is limited

Wide range of applications

- Nondestructive inspection
 - residual stress in train rails and aircraft parts
 - hidden failures of buildings and bridges
 - cargo inspection
- Boron neutron capture therapy
- Detector development

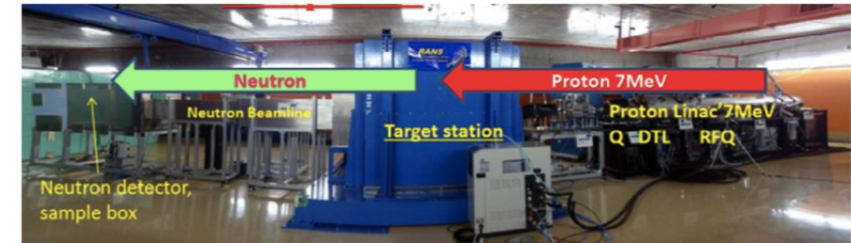

RANS (RIKEN, JAPAN)
 $E_p = 7\text{MeV}$; $I_{av} = 100\mu\text{A}$

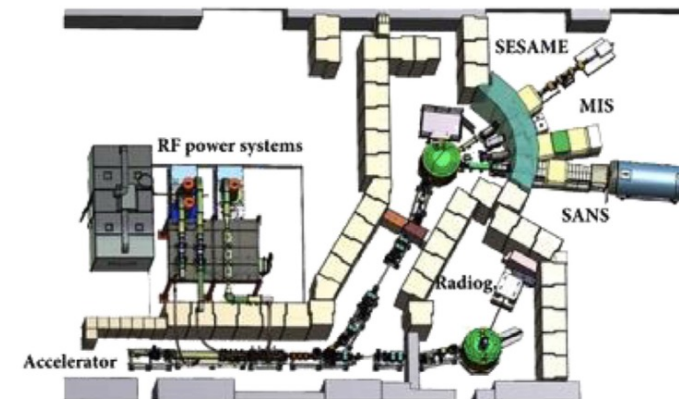

LENS (Bloomington, IN, US)
 13MeV ; 20mA ; $I_{av} = 0.24\text{mA}$

10 – 30 m long

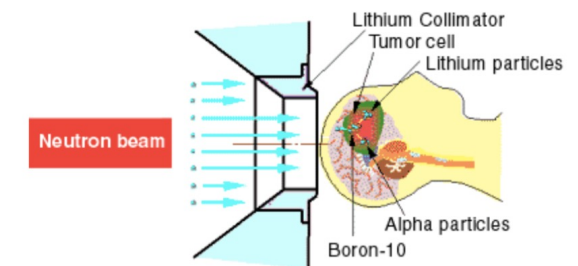
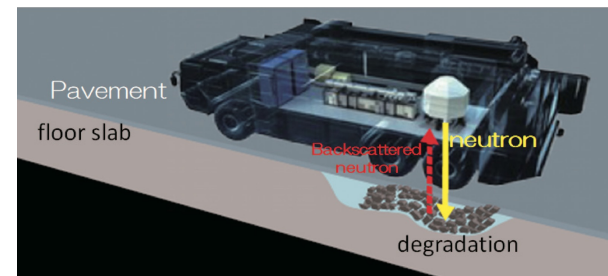

Neutron production with proton beam

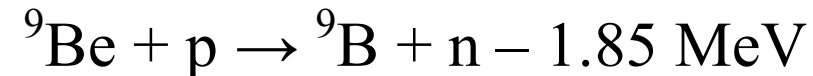
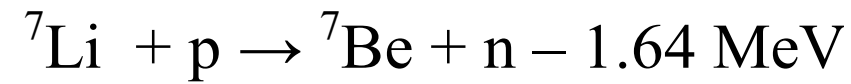
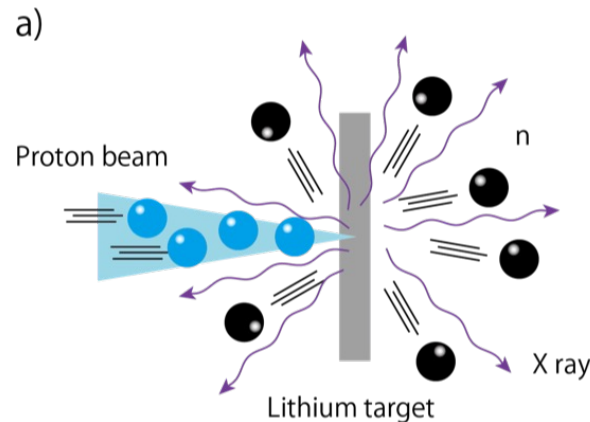

Y. Zuo, et al, "Neutron yields of thick Be target bombarded with low energy deuterons"

- These reactions are endothermic and undesired radiations could be reduced if beam energy is near the thresholds.
- However, since the proton is lighter than target atoms, the neutrons are produced in 2 p direction and only small fraction can be used.
- Therefore, higher beam energy is used to increase neutron flux.

Neutron production with proton beam

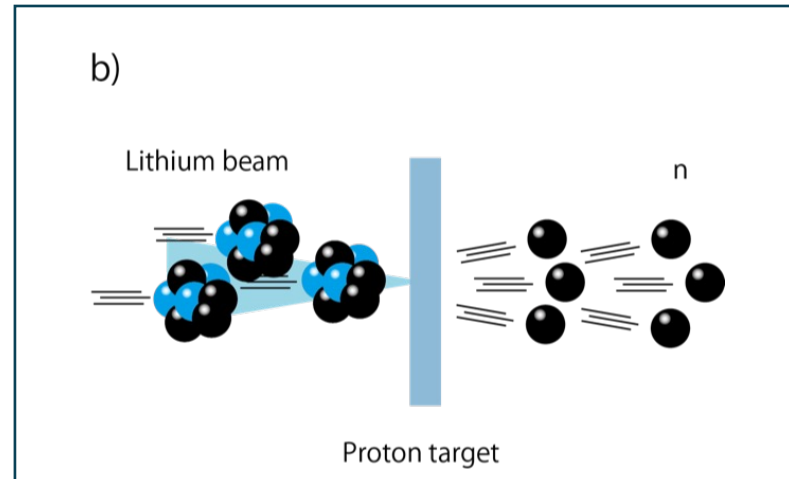
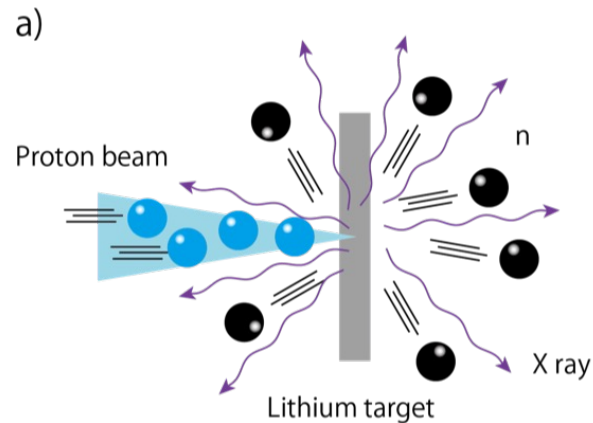

- If lithium ions are injected, neutrons are directed to forward because of the high gravity center velocity.
- Neutron flux can be increased while beam energy is kept near the threshold.

Previous Research: Demonstration with electrostatic Tandem accelerator

M. Lebois *et al.*, "Development of a kinematically focused neutron source with the $p(7\text{Li}, n)7\text{Be}$ inverse reaction," *Nuclear Instruments and Methods in Physics Research Section A: Accelerators, Spectrometers, Detectors and Associated Equipment*, vol. 735, pp. 145–151, 2014.

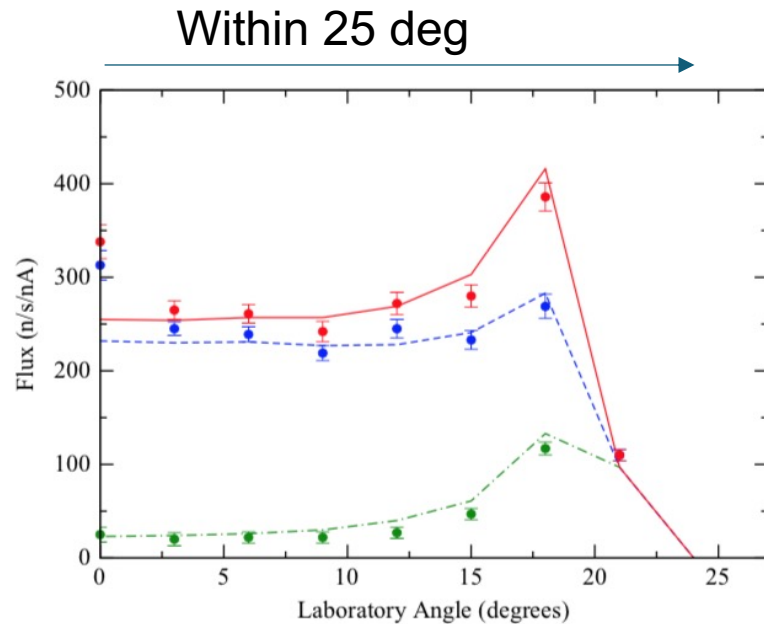

Angular distribution of neutron flux

- Advantage

The kinematic focusing technique clearly offers some distinct advantages over standard isotropic quasi-monoenergetic sources:

1. The focusing enhances the available neutron flux by a factor of between 25 and 100.
2. The lack of neutron emission at most angles results in much lower fast and thermal scattered neutron backgrounds in the experimental hall.

- Disadvantage (conventional heavy ion machine)

available beam current of ${}^7\text{Li}$ is much lower than that available for protons in the non-inverse reaction, because of the relative difficulty of extraction of ${}^7\text{Li}$ -ions from the ion source. Secondly,

Tandem $\sim \mu\text{A}$, ECR $\sim \text{mA}$, proton driver 10s of mA

Intense beam production using LIS and RFQ: Direct plasma injection scheme

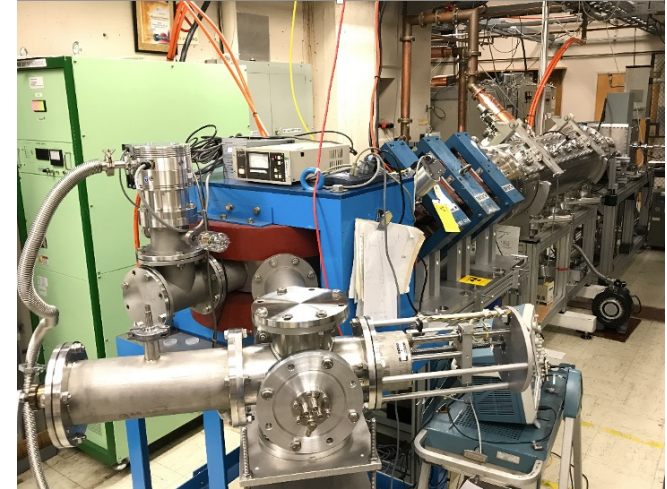
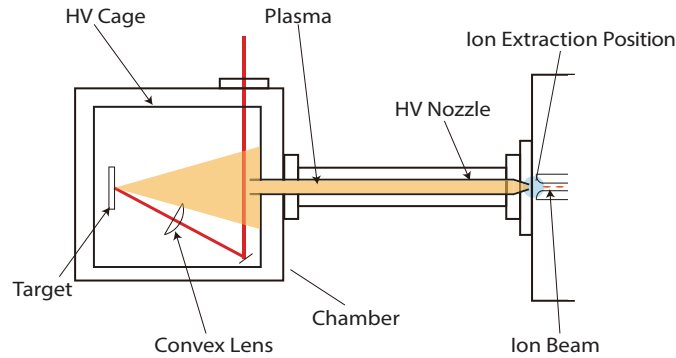

- Plasma is generated by laser ablation and injected into RFQ
- Beam extraction is done in RFQ
- No need to build low energy beam transport (LEBT)



High density plasma directly converted to bunched beam.

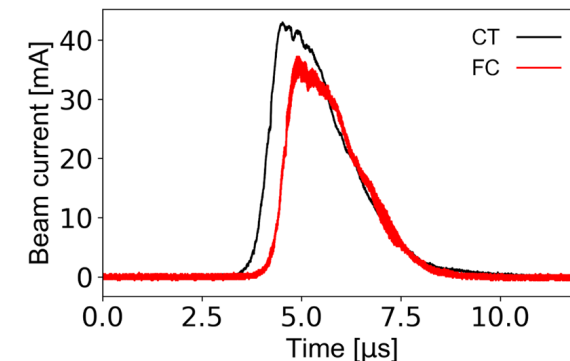

Compact neutron source using intense Li ion beam driver

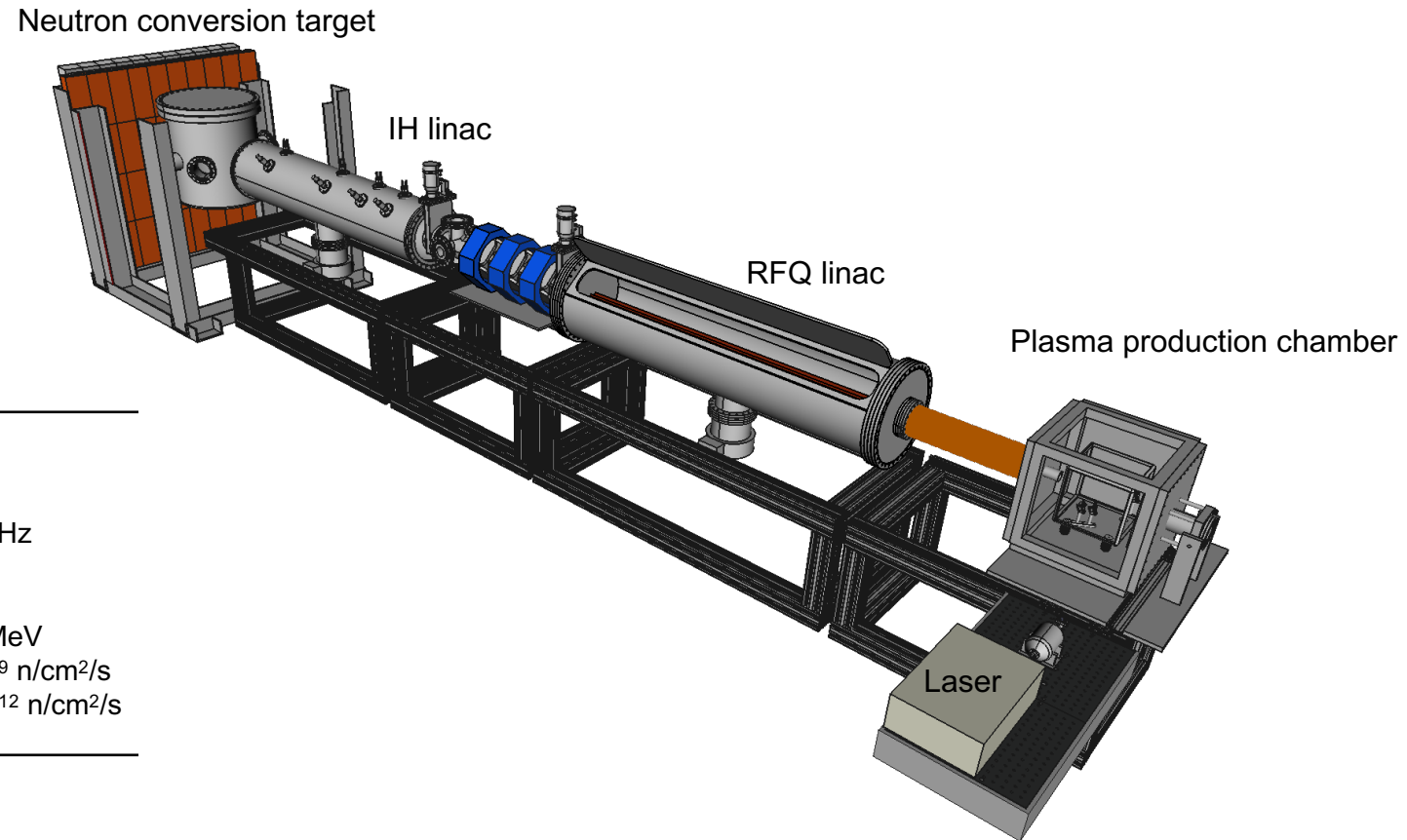

Ion	${}^7\text{Li}^{3+}$
Ion beam energy	14-20 MeV
Beam pulse width	0.1-5 μs
Repetition rate	100 Hz – 1kHz
Peak ion beam current	10 - 100 mA
Average ion beam current	10 - 100 μA
Neutron energy	1 MeV -10 MeV
Average neutron flux	Up to 1×10^9 n/cm ² /s
Peak neutron flux	Up to 1×10^{12} n/cm ² /s
Length	< 8 m

Development topics to realize compact neutron source

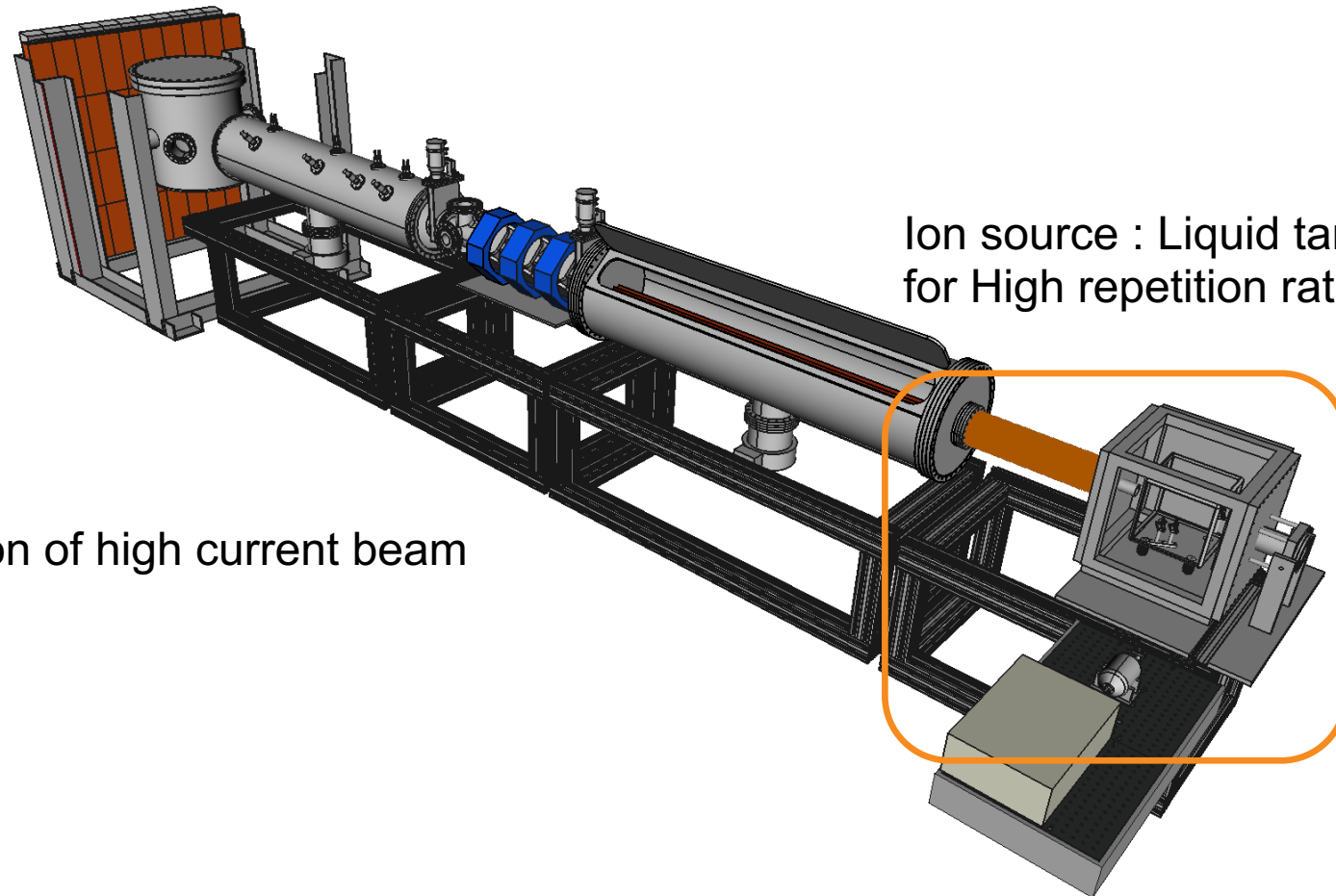

Ion source : Liquid target development for High repetition rate

Accelerator : Acceleration of high current beam

Laser target development for high repetition rate and long-time operation



Present technology

- Solid target should be moved every shot to provide a fresh surface $\sim 1\text{Hz}$
- Enormously large surface area is needed for long time operation
- This limits the total yield of lithium ions

Liquid target to overcome limitation

- a liquid target can fully recover surface flatness after any laser shot
- laser shots can be fired on the same spot
- e.g.) 100 mA peak, 1 μs pulse width,
 - 100 Hz = 10 μA average,
 - 1 kHz = 100 μA average
 - Enough for imaging
 - Possible to use it for isotope production

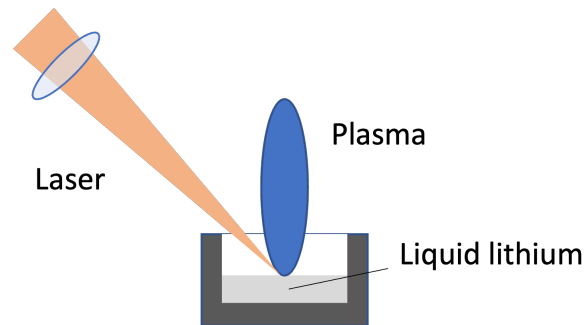

Static target (Crucible)

- Simple -> **Good**
- Surface oscillation -> **Research topic**

Topic 1. Optimization of laser irradiation condition

- Laser power density ($I_L = \frac{E_L}{\tau A}$ [W/cm²]) determines plasma property
 - Higher I_L gives larger number of ${}^7\text{Li}^{3+}$
 - Laser spot size, A , should not be changed for stable production of plasma
- Influence of surface oscillation needs to be minimized
 - Lens to target distance is changed by oscillation
 - Oscillation should be about Rayleigh range or smaller
- Optimum condition needs to be searched experimentally
 - Small spot size \leftrightarrow Long Rayleigh range
 - Laser energy \leftrightarrow Oscillation amplitude, Cost

FIGURE 17.6
Diffraction spreading of two gaussian beams with different spot sizes at the waist.

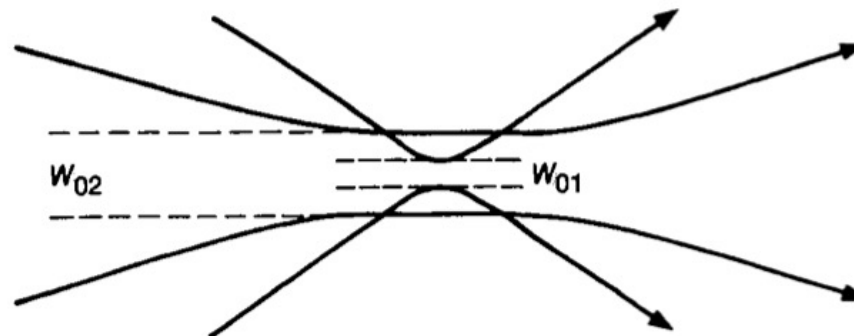

Ion analyzer to measure ${}^7\text{Li}^{3+}$ in plasma

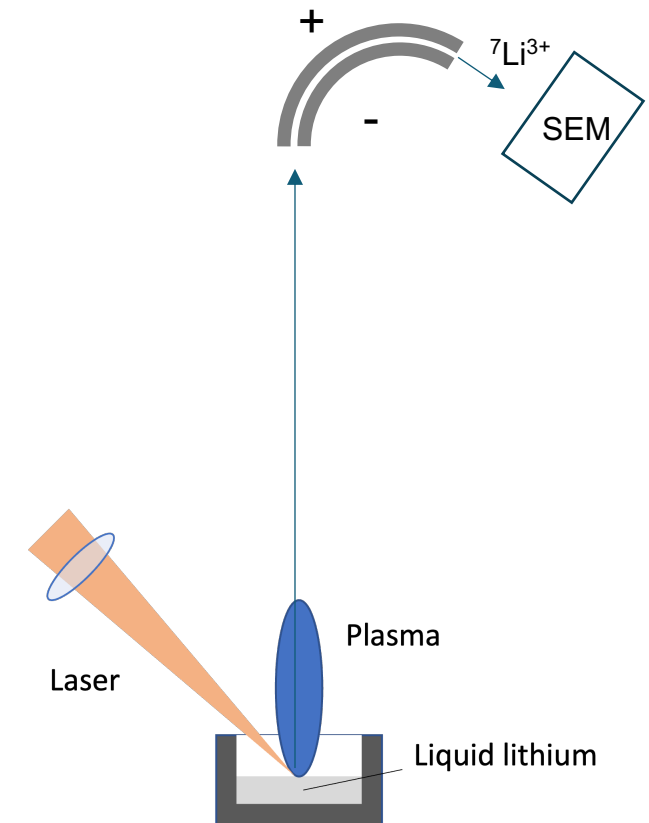

2. Crucible shape investigation

Enhancement of damping

- Surface oscillation should be small
- Damping depends on geometry, viscosity, and surface tension
- Damping can be maximized by using appropriate geometry or obstacles

Splashing prevention

Ring Baffles

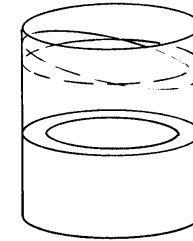

4 Cruciform Baffle

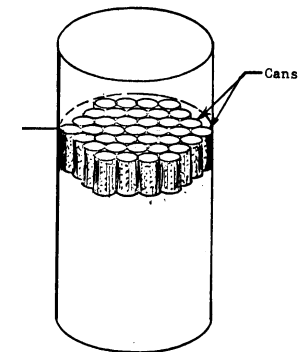
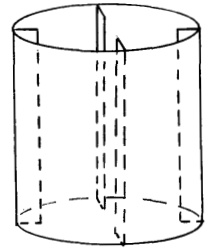

J. R. Roberts et al. "Slosh design handbook", NASA CR-406

3. Shielding structure

Internal shielding is needed to:

- Avoid direct exposure of welded part to plasma
- Reduce radiative cooling
- Control lithium accumulation
 - Temperature should be controlled to guide vapor to prepared accumulation point

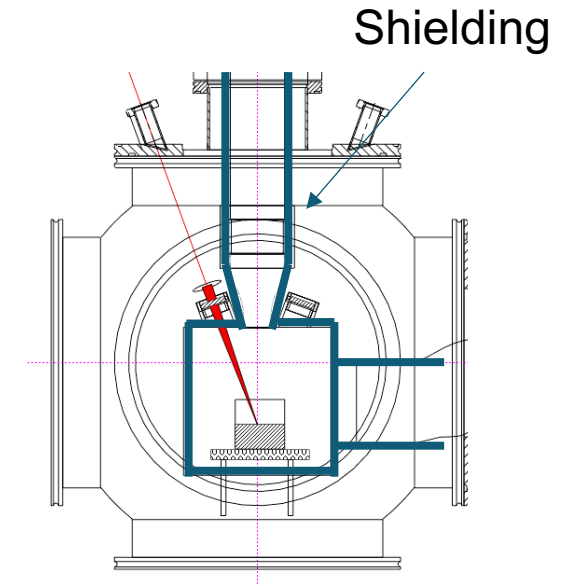

Vertical Plasma Analyzer line - Conceptual Design

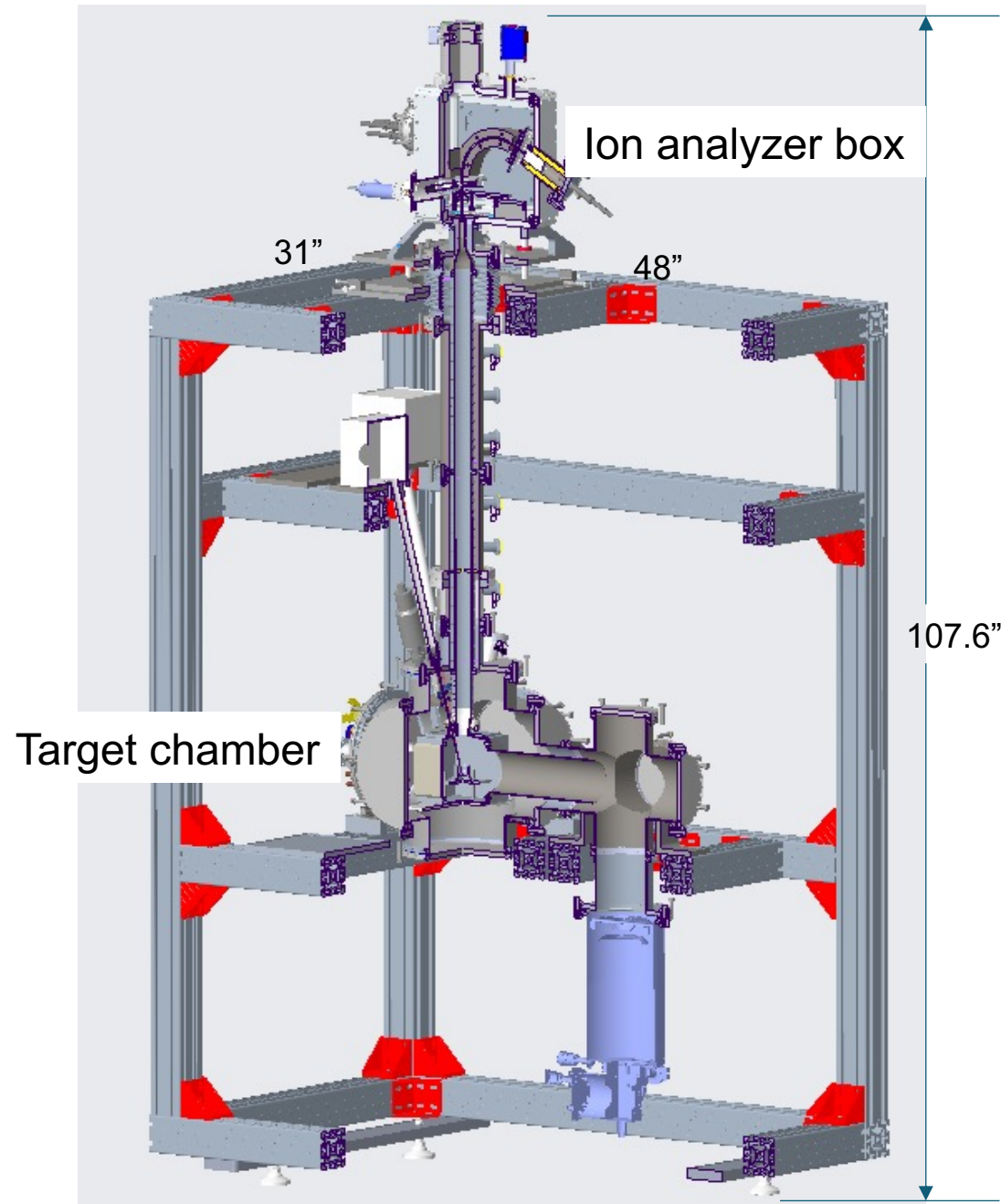
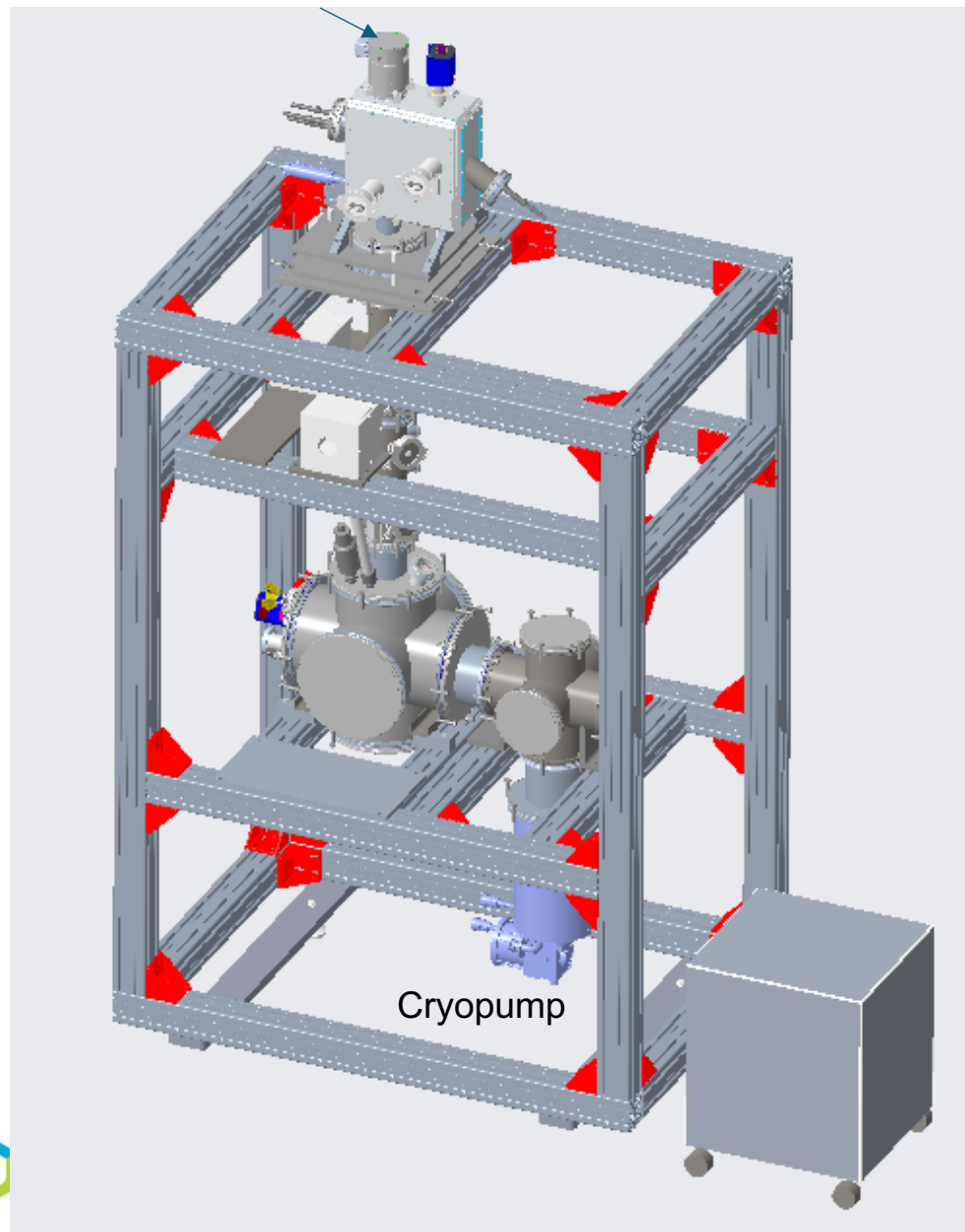

Liquid Lithium Target chamber (Lower Section)

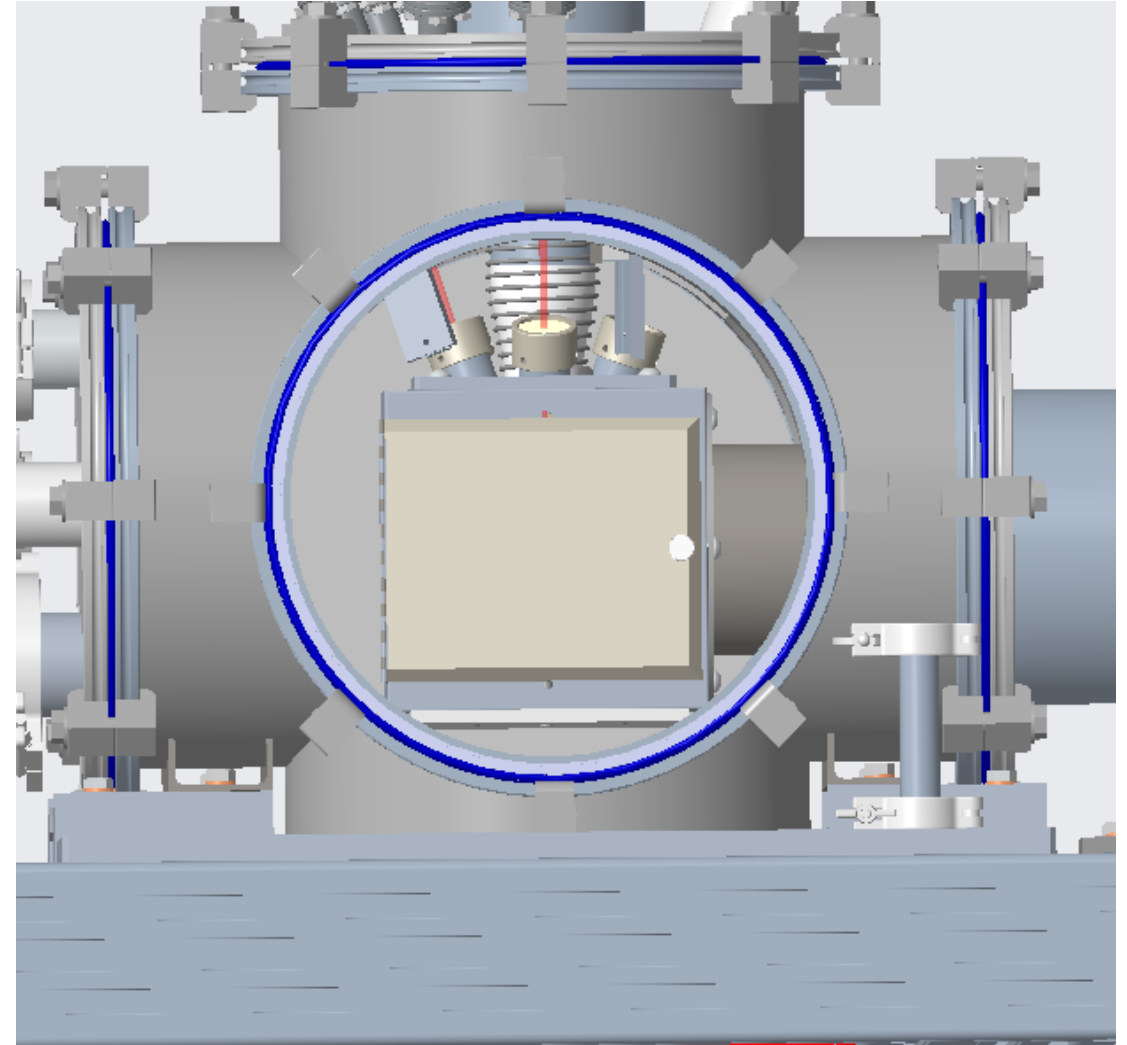
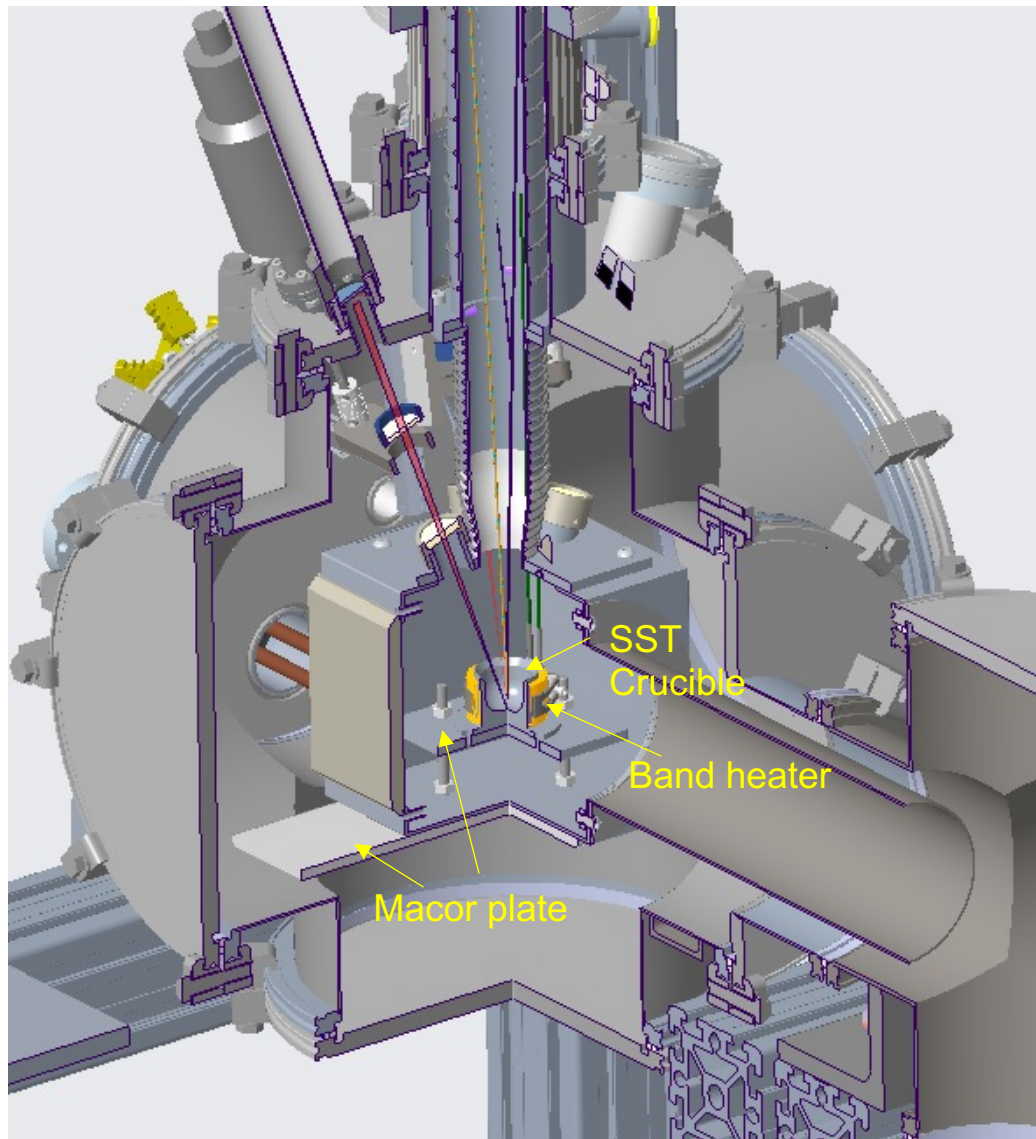

Liquid lithium Temperature will be maintained at 200 oC

Middle Section

Laser Optical Box

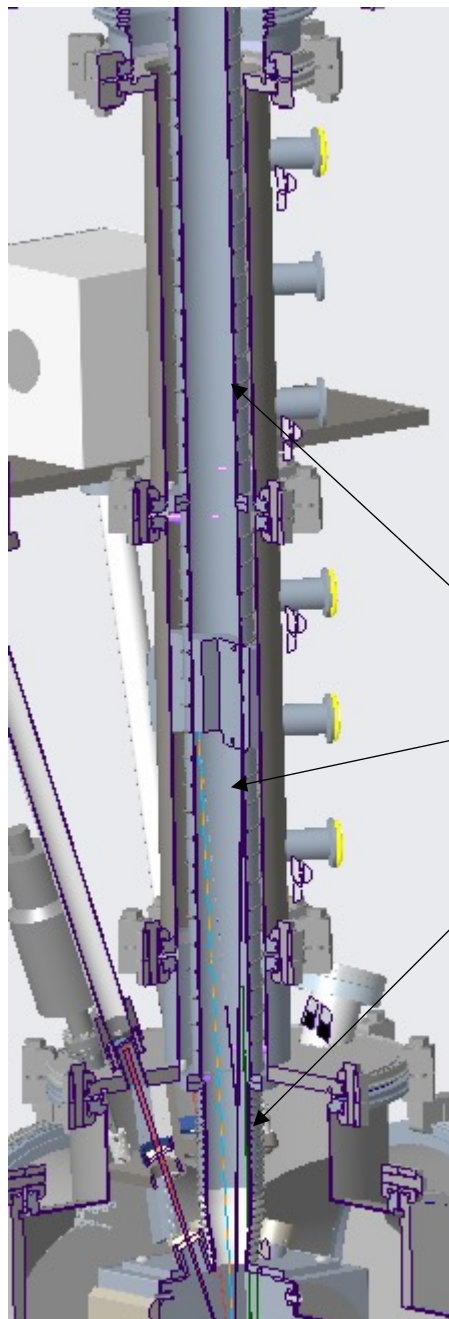
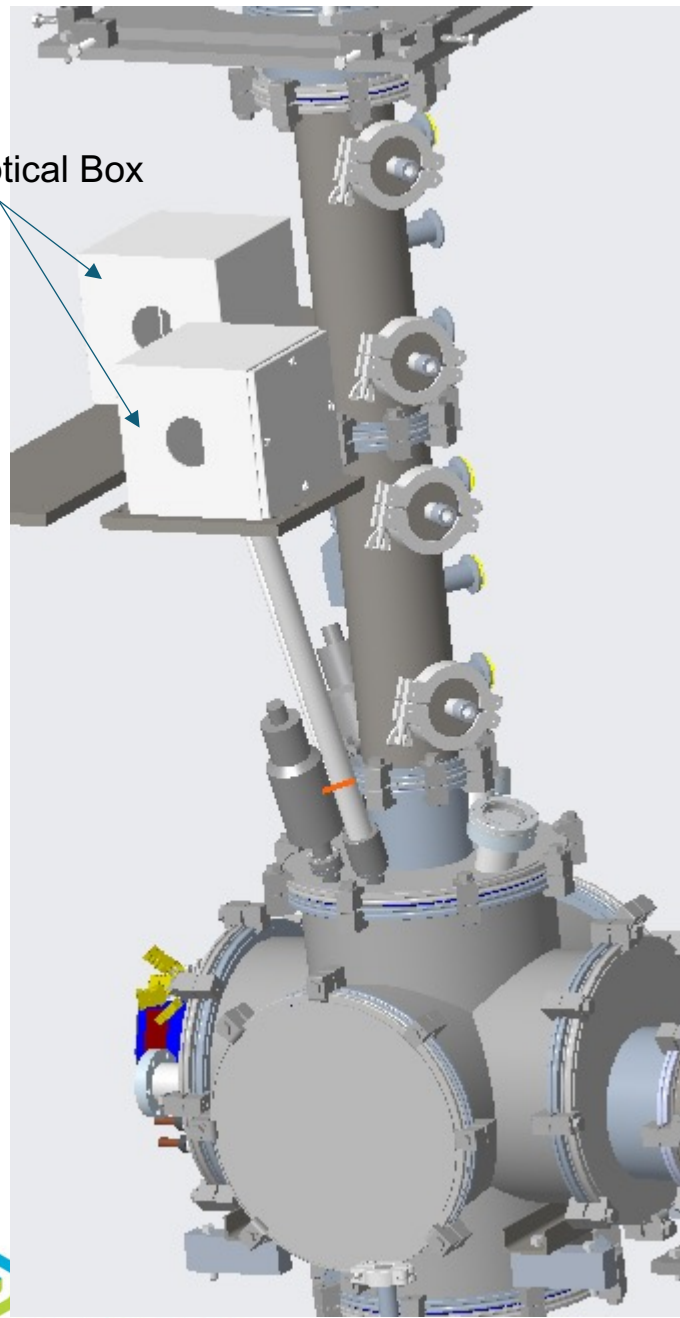

Temperature on the inner pipe will be maintained at 200 oC.

Silicon Belt Micro heaters wrapped around the inner beam pipe (3 sections). Rating: 100 V, 600 W



Ion Analyzer box

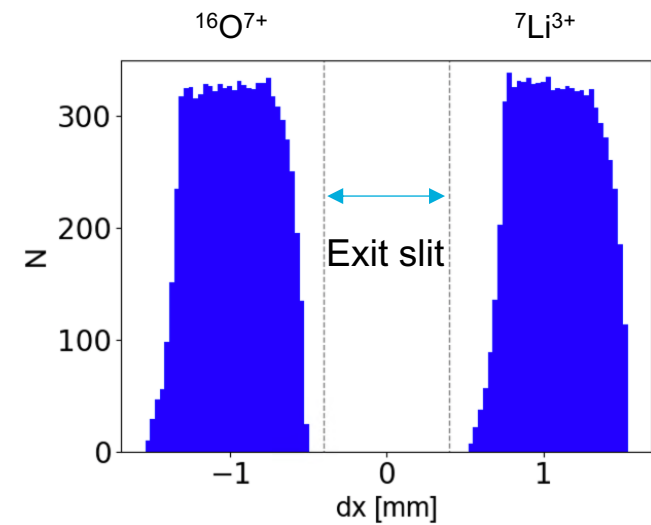
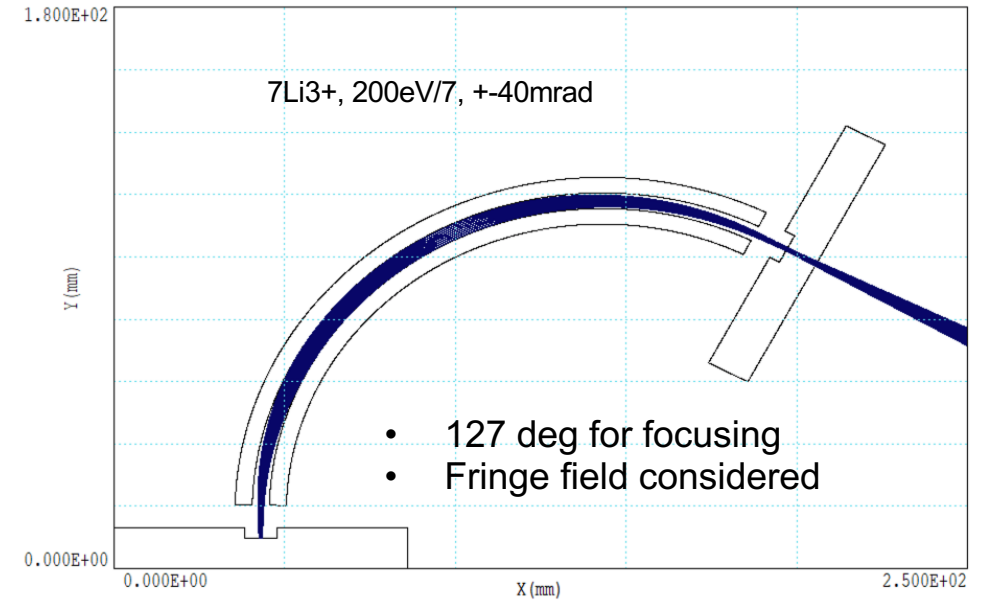
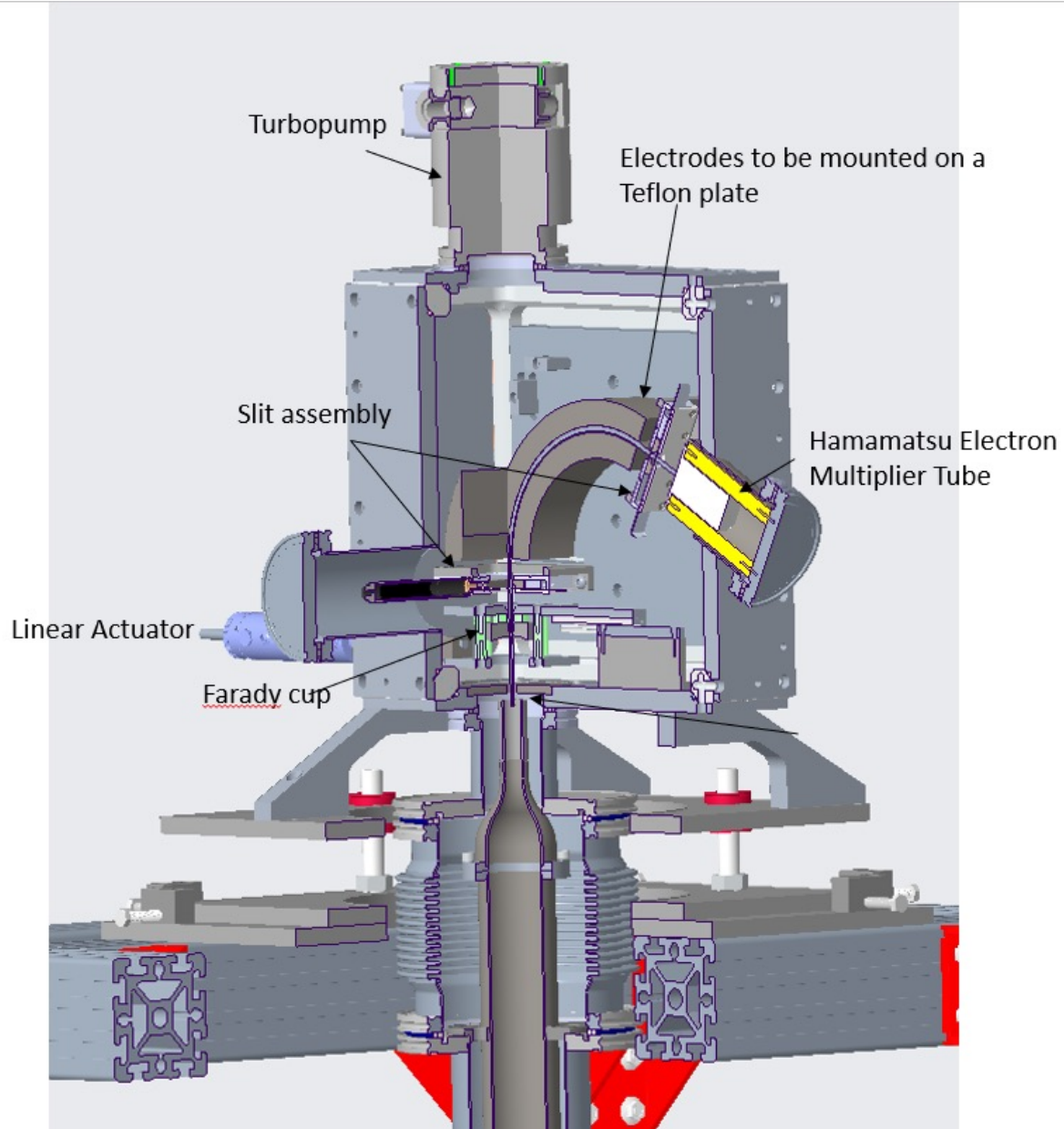

- O^{7+} and Li^{3+} can be resolved with a 0.8 mm slit

Lithium Handling

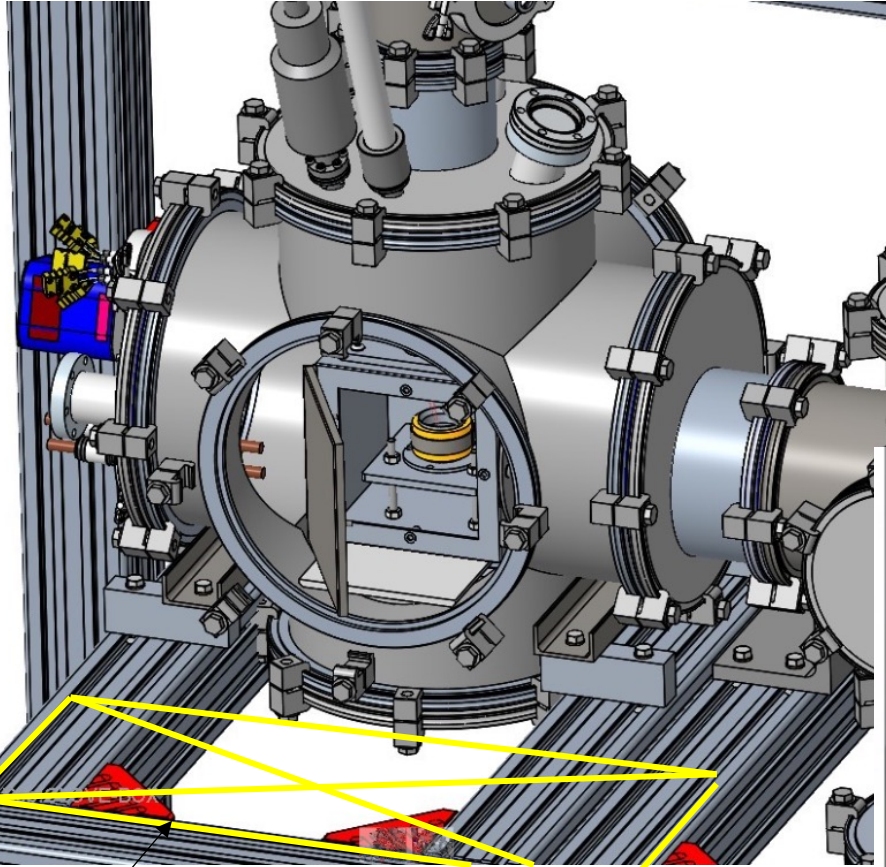

A Table



Filled with Argon

Surface oscillation measurement

- Surface oscillation excited by laser will be measured with a laser displacement sensor
- 0.1 mm accuracy, 0.3 mm spot, 1 kHz sampling

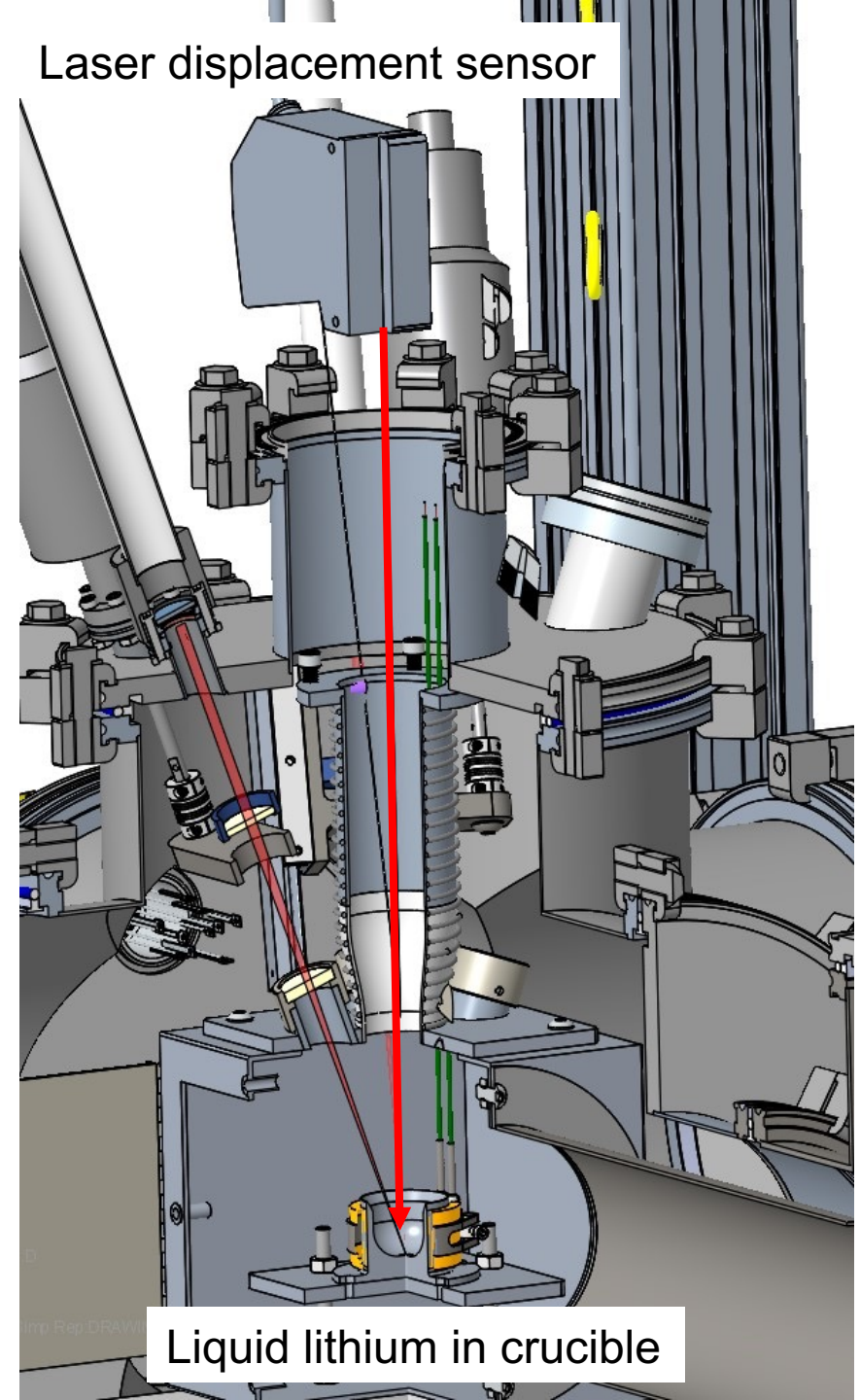

Experiment with liquid Ga

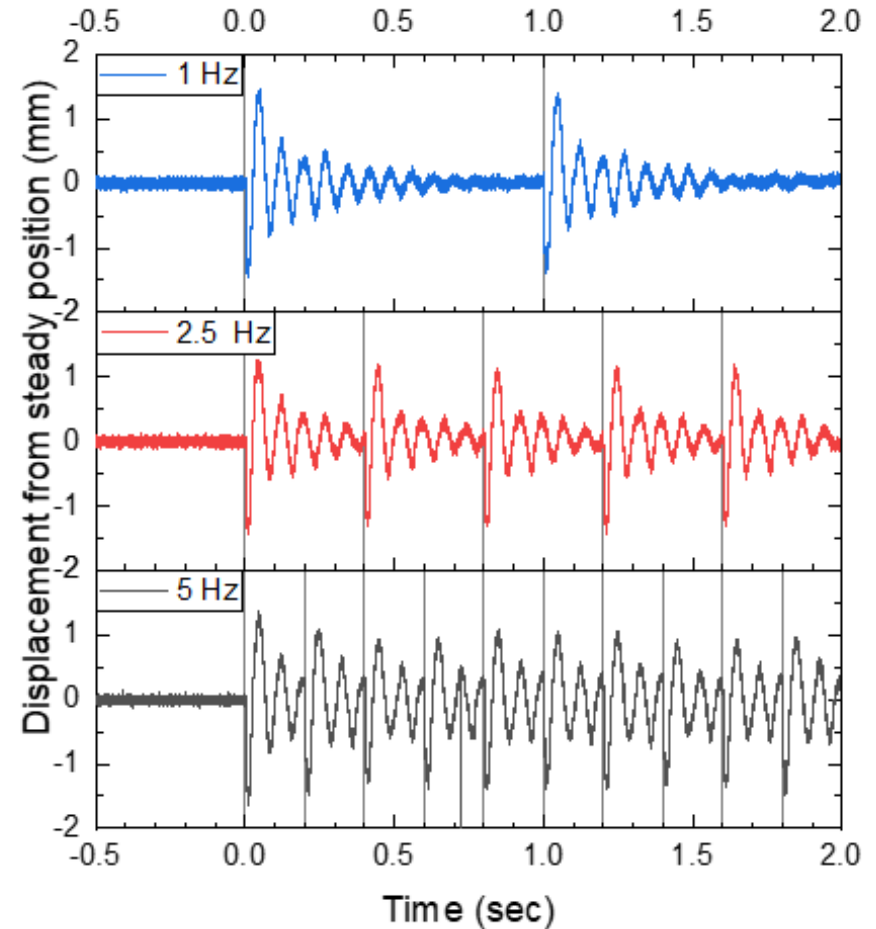
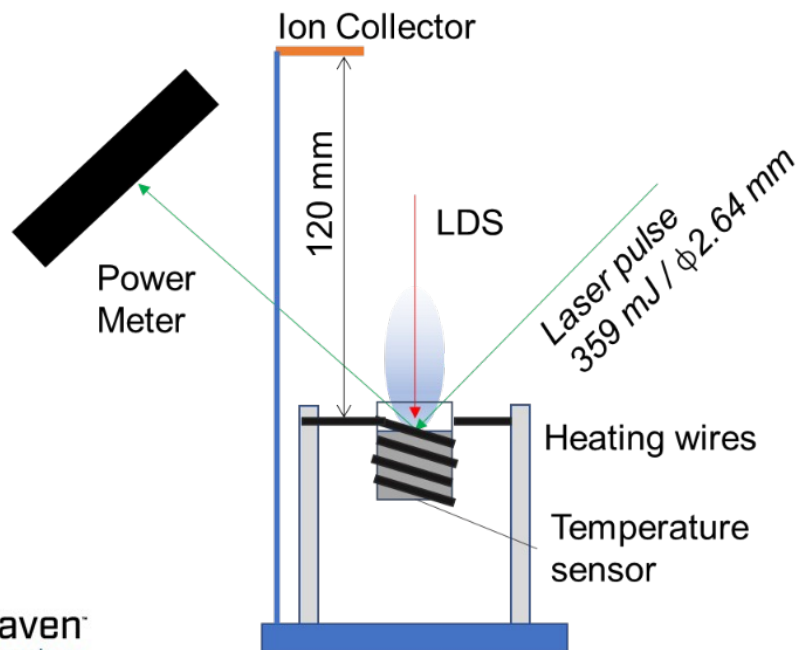

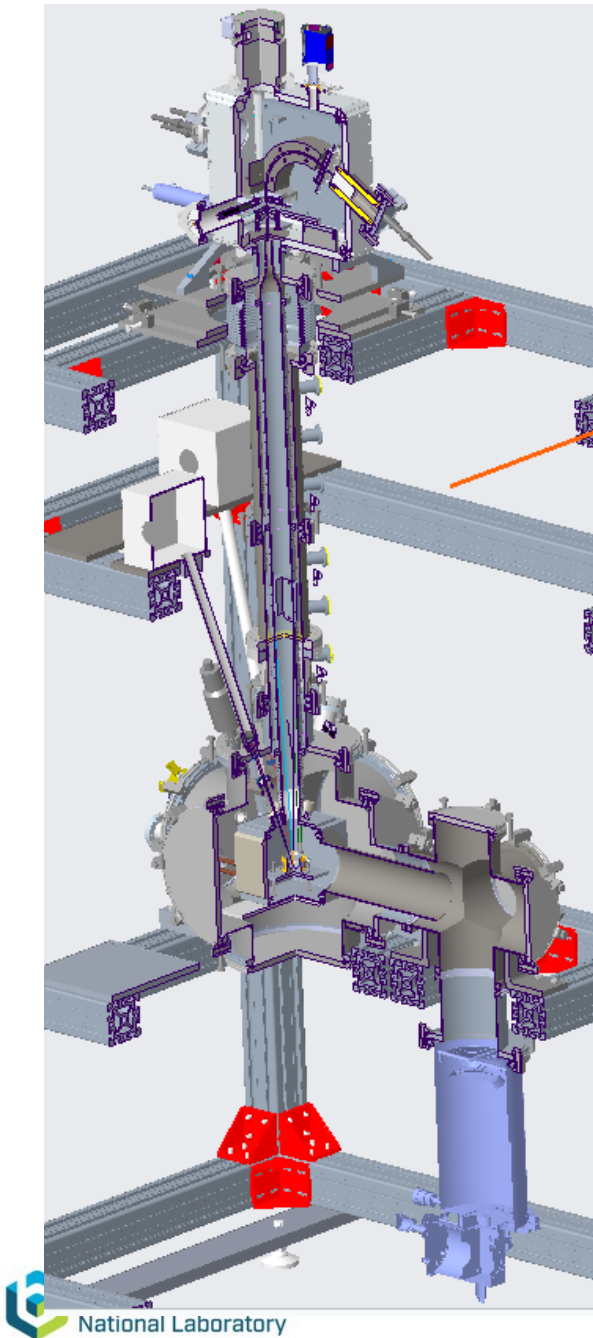

The system will be under vacuum during the operation.

Vapor Pressure of Liquid Lithium at 200 °C is very small ($\sim 10^{-9}$ Torr).

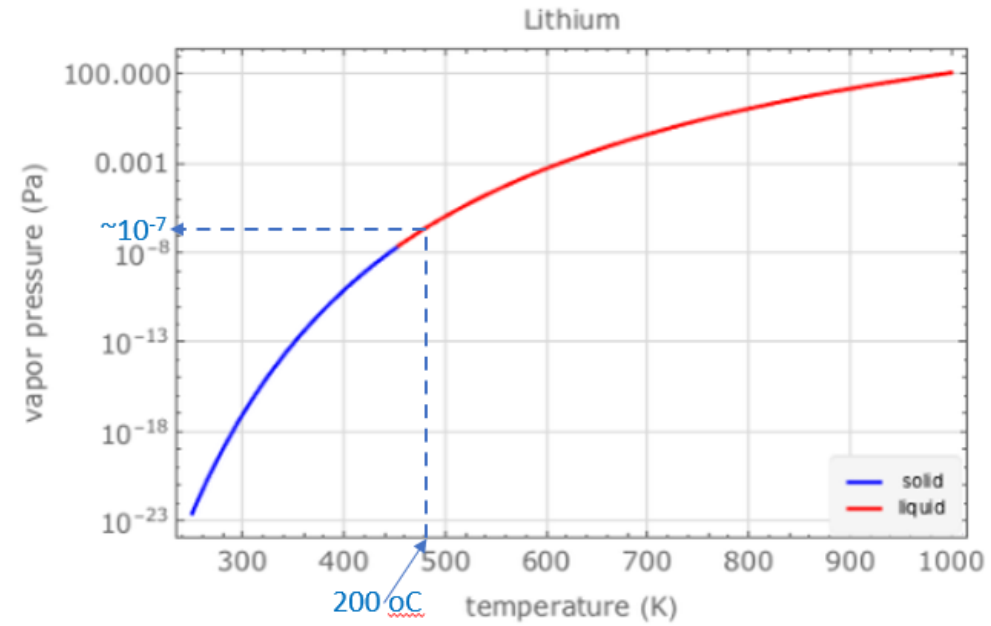

1 Pa = .0075 torr

A Thermal Analysis on the vacuum chamber

A: Steady-State Thermal

Temperature
Type: Temperature
Unit: °C
Time: 1
10/25/2023 1:05 PM

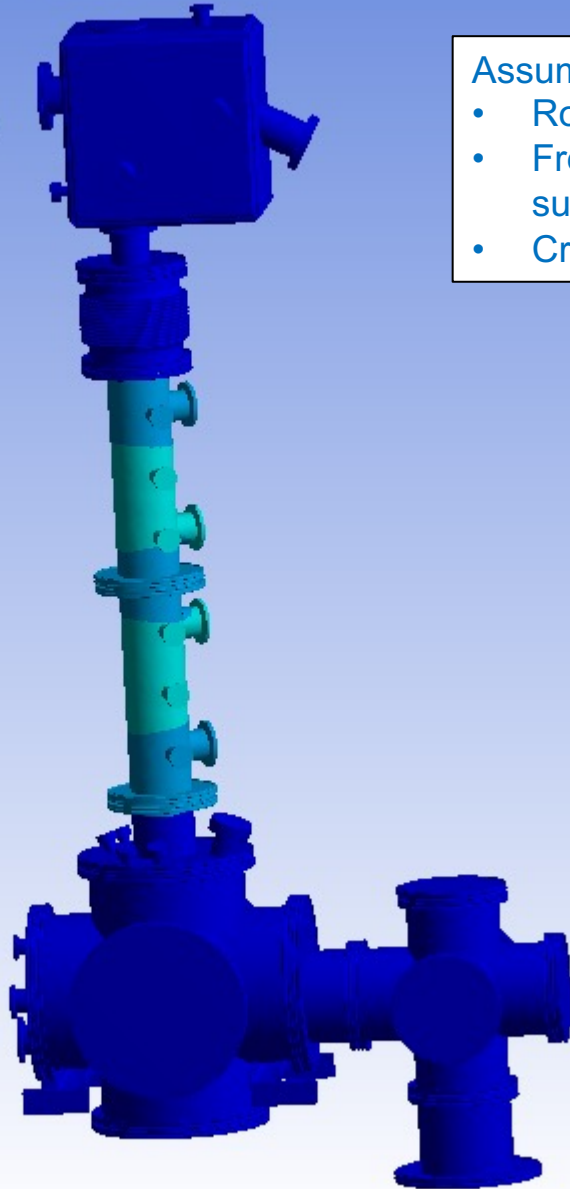

Assumptions:

- Room temp: 22 °C.
- Free heat connection on the outer surface. $H=2.5 \text{ W/m}^2\text{-K}$
- Crucible and inner pipe temp: 200 °C.

A: Steady-State Thermal

Temperature
Type: Temperature
Unit: °C
Time: 1
10/25/2023 1:03 PM

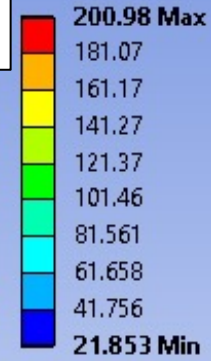

Research goals for the rest of project

Experiment will be done for;

- Optimization of laser irradiation condition using ion analyzer,
- Determination of crucible structure to mitigate surface oscillation,
- Test of shielding structure,
- Simulation of high repetition rate irradiation with existing lasers to demonstrate the feasibility.

Summary

- An intense ${}^7\text{Li}^{3+}$ beam driver (100 mA peak) with combination of LIS and RFQ was proposed,
- A liquid lithium target system for LIS is essential for high repetition rate and long operation,
- Design of experimental apparatus to analyze plasma and liquid surface of lithium was finished,
 - Ion analyzer, Surface oscillation measurement, Shielding structure, Lithium handling
- After fabrication, experiment will start soon,
- Feasibility of liquid target will be shown with optimum laser irradiation condition and crucible shape.

Thank you

Concept of burst mode operation

