



dRICH Removal Considerations

Alex Eslinger (JLab)

7-25-24

Electron-Ion Collider

Motivation

- The goal is to allow for periodic maintenance to the inner detectors in the IR without breaking the beam pipe vacuum or rolling out the barrel.
- Two scenarios are being investigated:
 1. Keep the dRICH as one-piece
 - Move the dRICH back as far as practical (to the gate valve location)
 - Perform maintenance inside the barrel and on the primary dRICH electronics
 2. Split the dRICH in two halves (vertically)
 - Modify the beam pipe design so that the flange is placed in front of the dRICH instead of directly behind.
 - Move the dRICH just outside of the barrel and clear the existing services
 - Split the dRICH apart and pull one or both halves out of the way
 - Perform maintenance inside the barrel and on the primary dRICH electronics

Inner Beam Pipe Flange Considerations

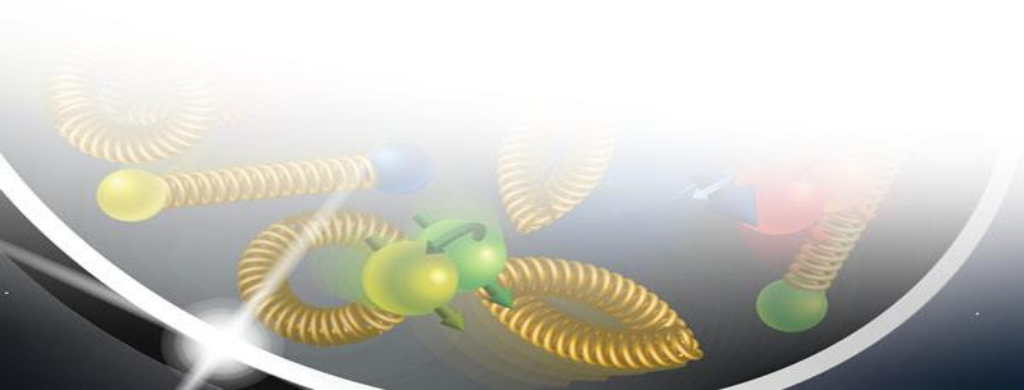

Symmetrical Inner Bore (Current)

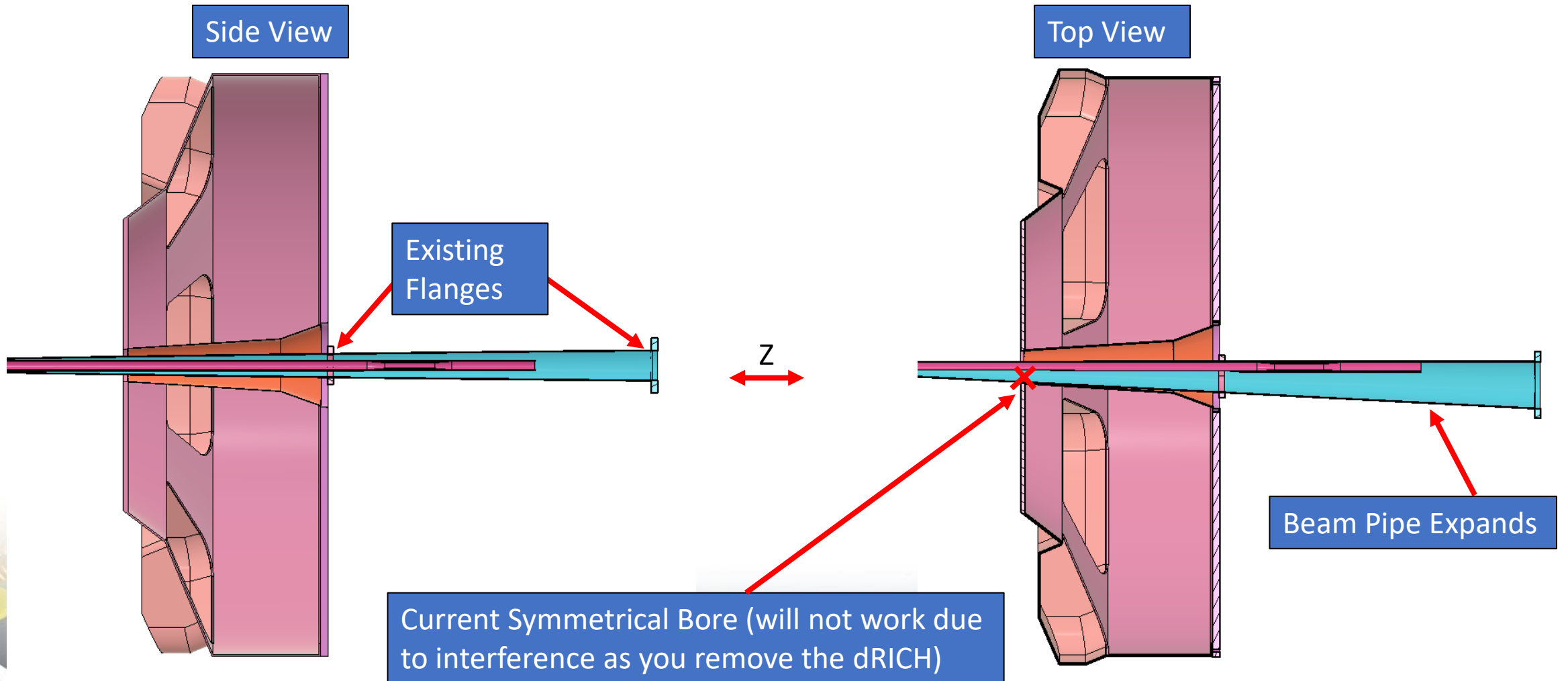

Option 1: Beam Pipe Flange Remains/One-Piece dRICH

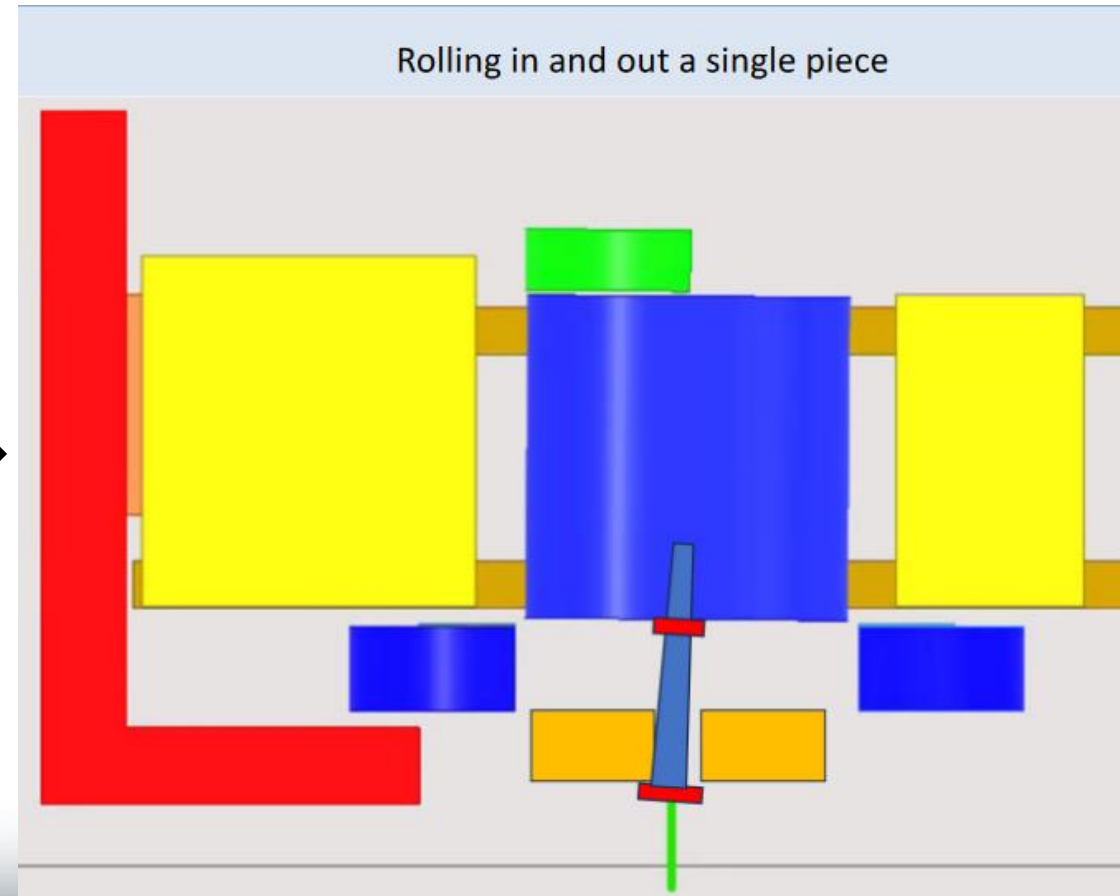
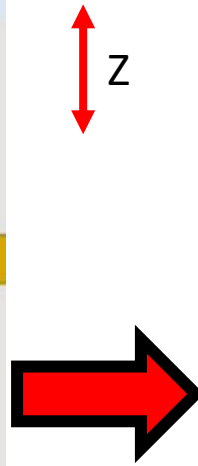
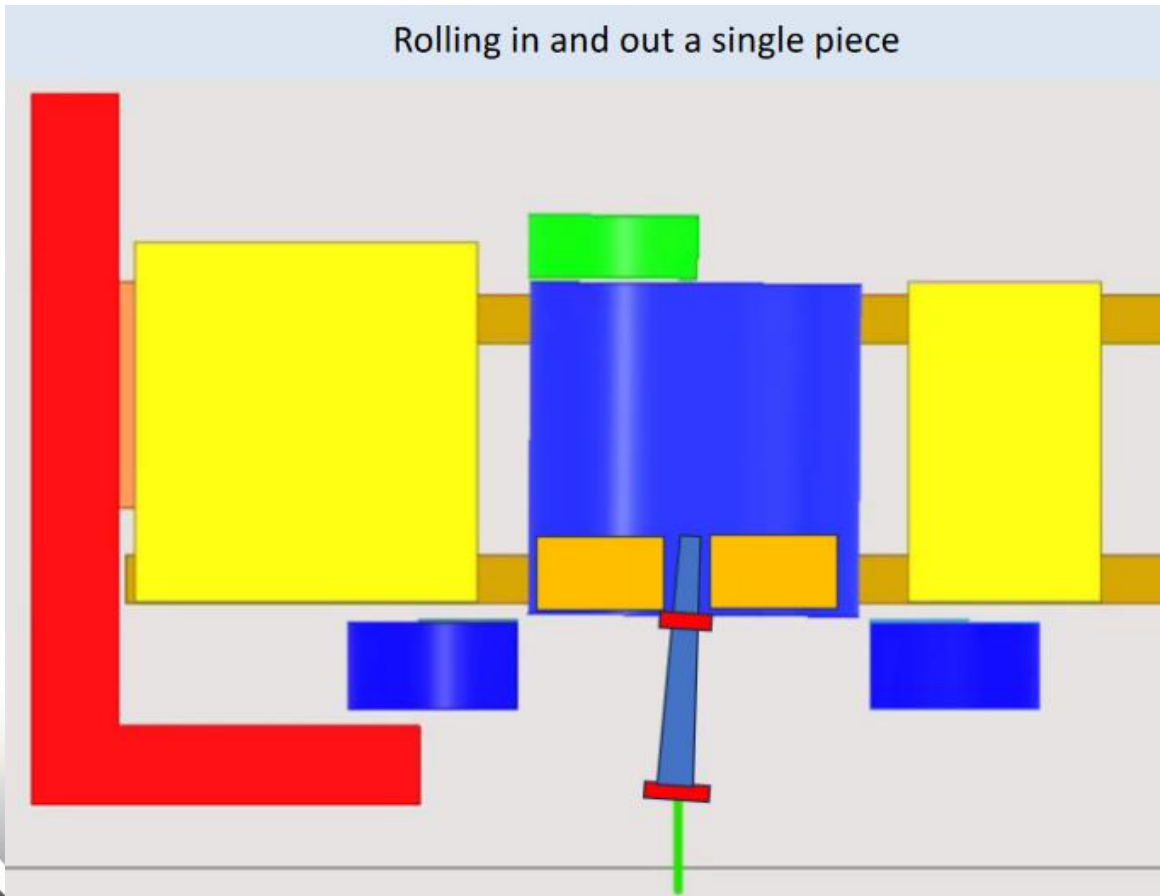

Top View of IR Hall

Option 1: Beam Pipe Flange Remains/One-Piece dRICH

1. The dRICH is pulled back to its “maintenance location” which is around the second flange (where the end cap typically sits in the running position). (198cm)
2. The inner bore of the dRICH needs to account for the first flange behind it as well as the expansion of the beam pipe.
3. 5mm clearance is added radially for every feature that needs to clear the beam pipe

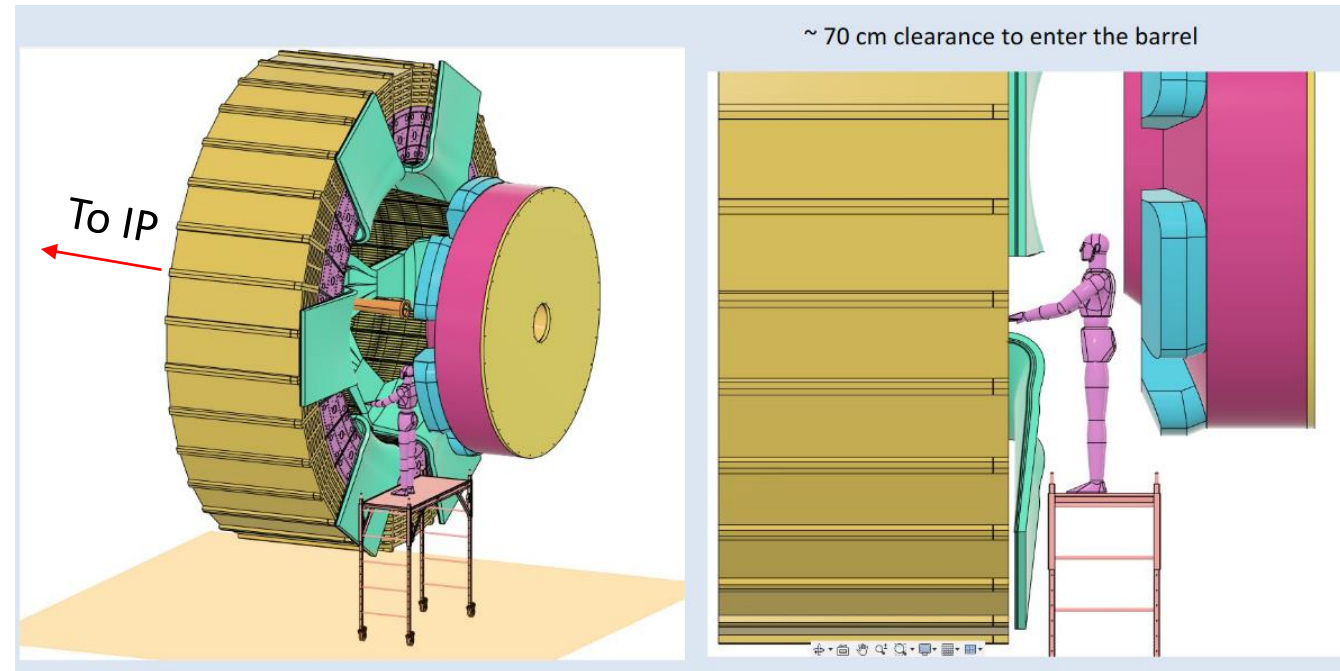

Option 1: New Inner Bore

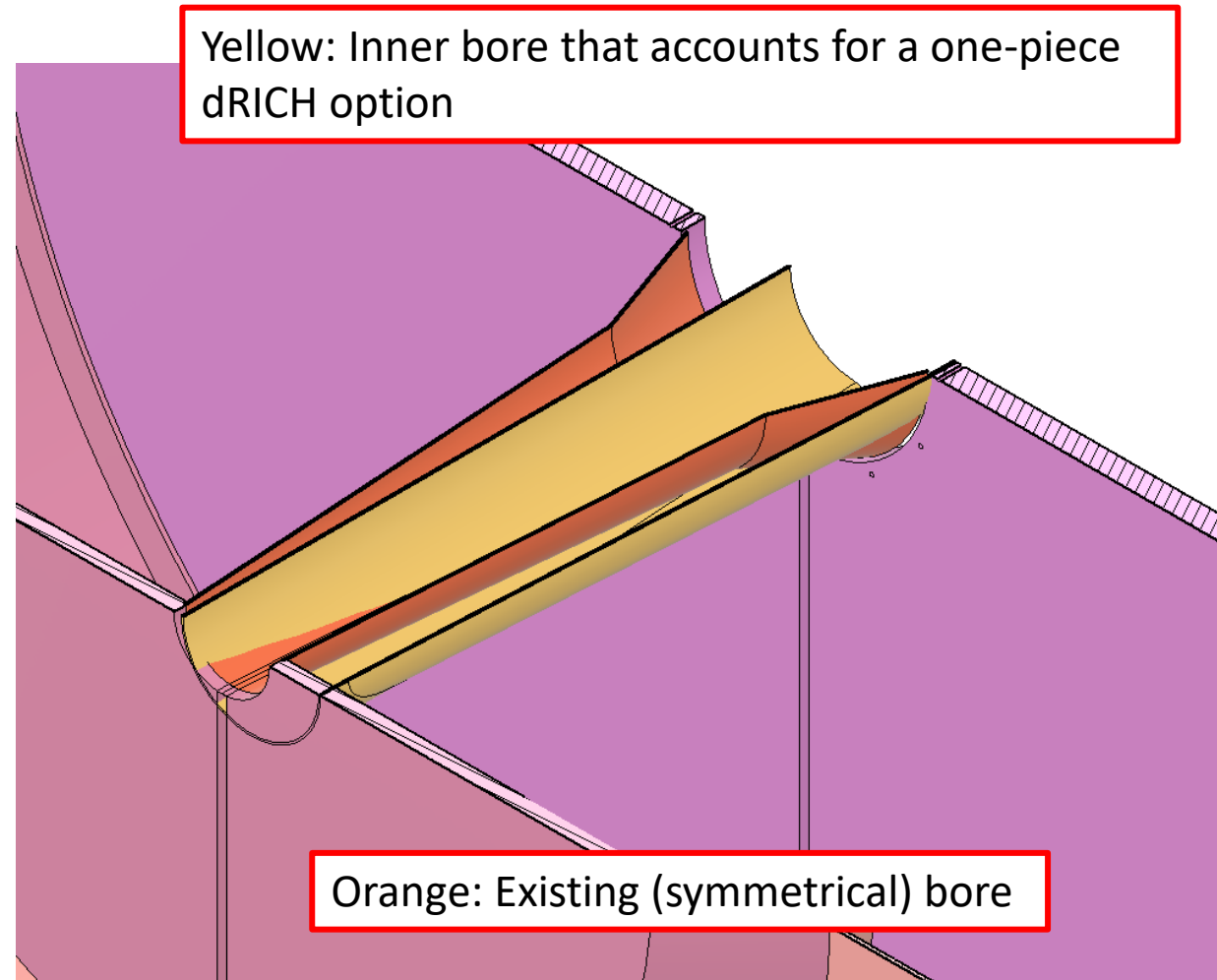
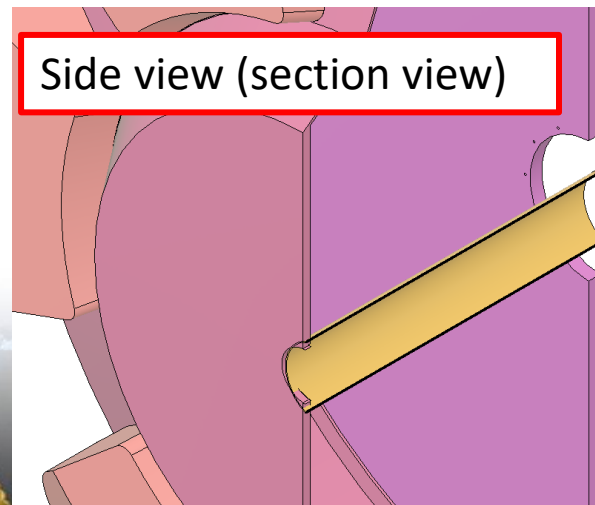
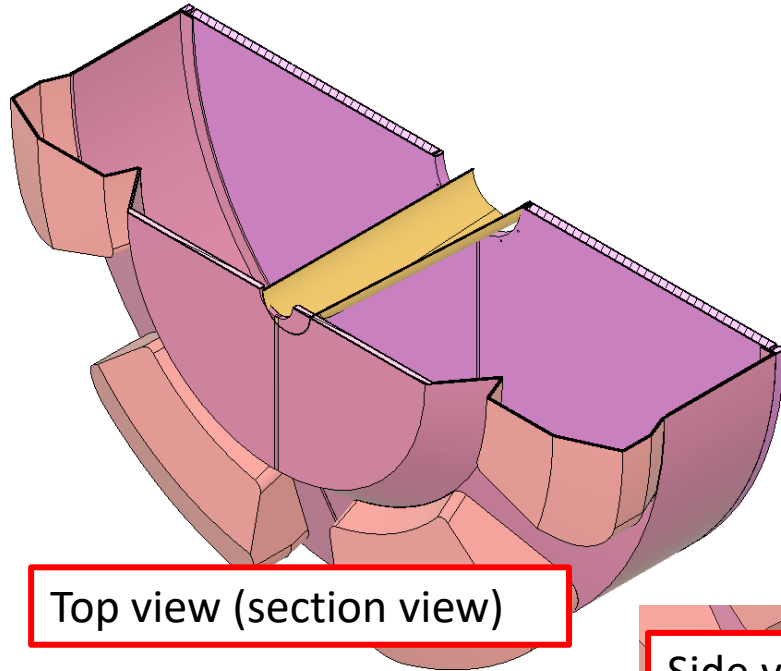

This is the smallest bore available to us for the first option. It assumes that the dRICH is pulled out 198 cm from its nominal location. It has an included 5mm clearance from the beam pipe at each location.

Option 1: New Inner Bore

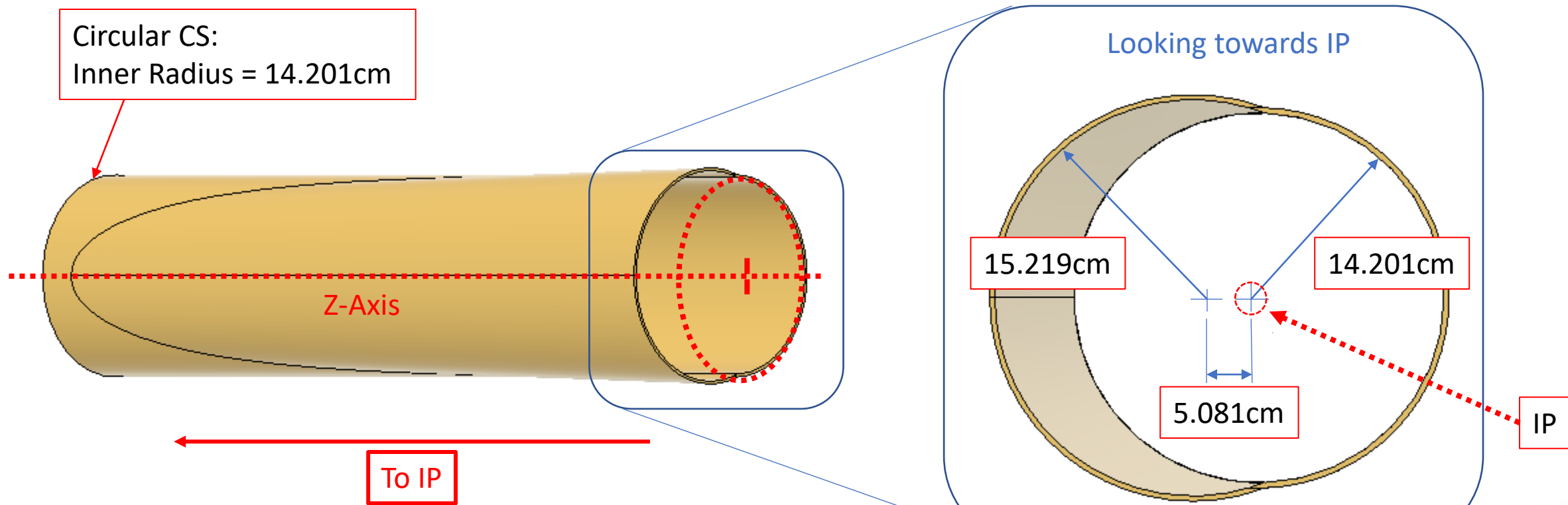

Option 2: Move Beam Pipe Flange & Two-Piece dRICH

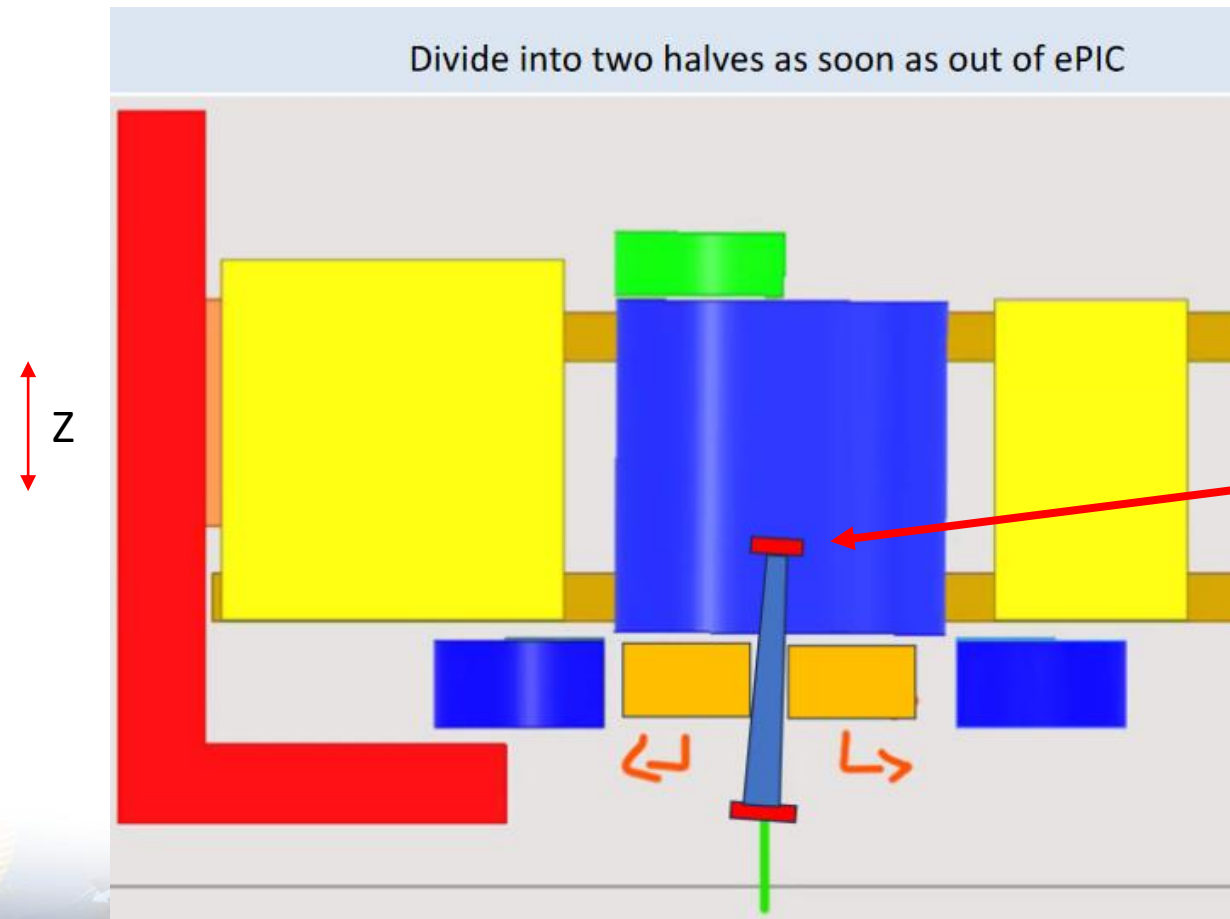

Note: Since the dRICH splits, we can move the flange to the front of the dRICH

Top View of IR Hall

Option 2: Move Beam Pipe Flange & Two-Piece dRICH

1. The dRICH is pulled back to its “removal location” which is just far enough back to clear the inner detector services (150cm)
2. The dRICH is split apart and one or both halves are moved away from the barrel
3. The first beam pipe flange is relocated to just in front of the dRICH
4. 5mm clearance is added radially for every feature that needs to clear the beam pipe

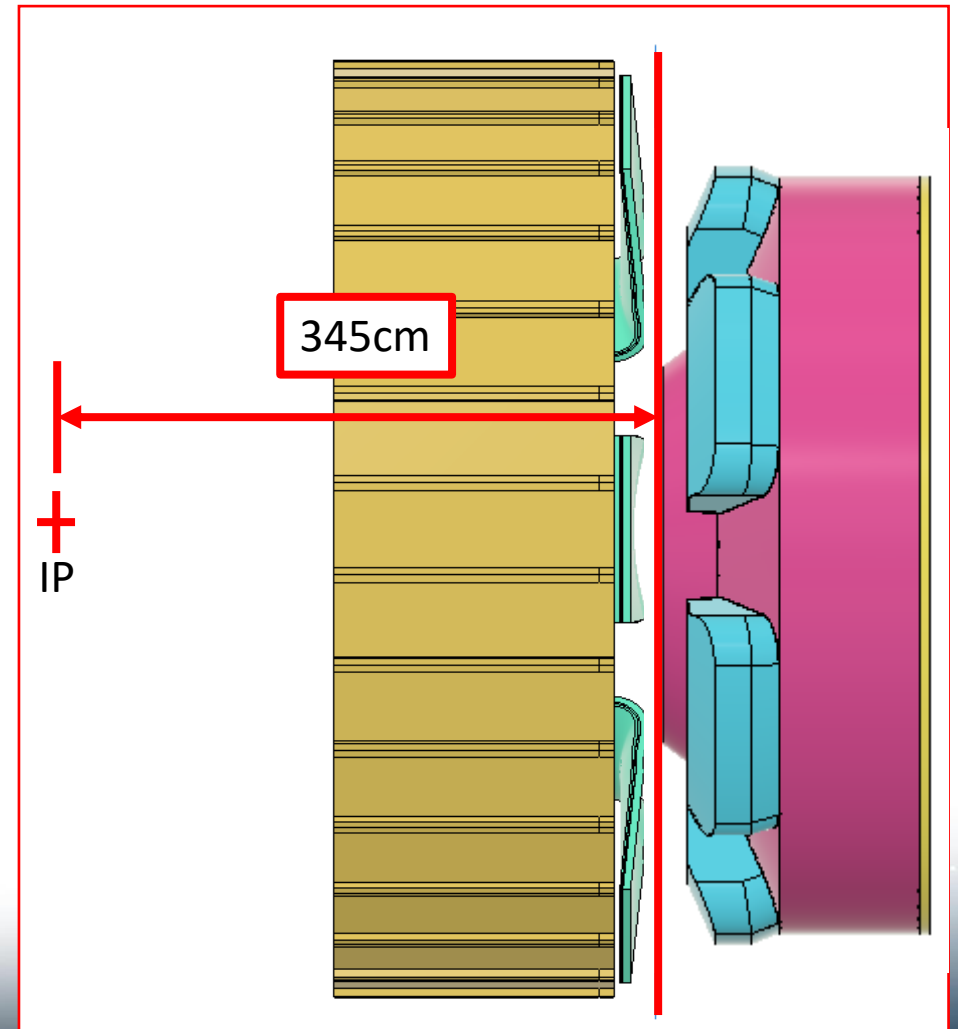

Option 2: New Inner Bore

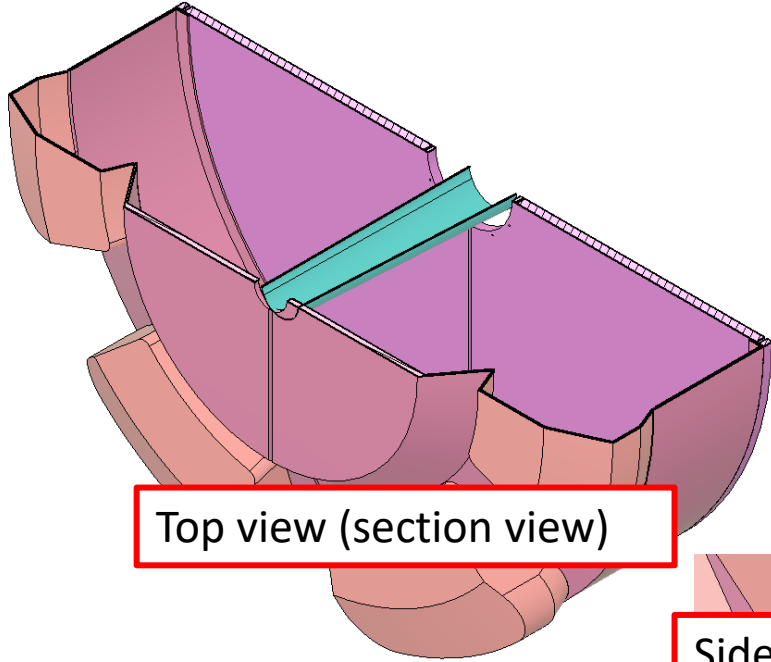

Top view (section view)

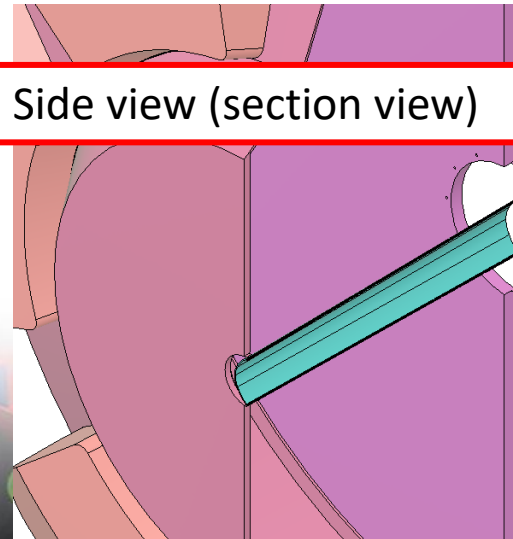

Side view (section view)

Teal: Inner bore that accounts for the two-piece dRICH option

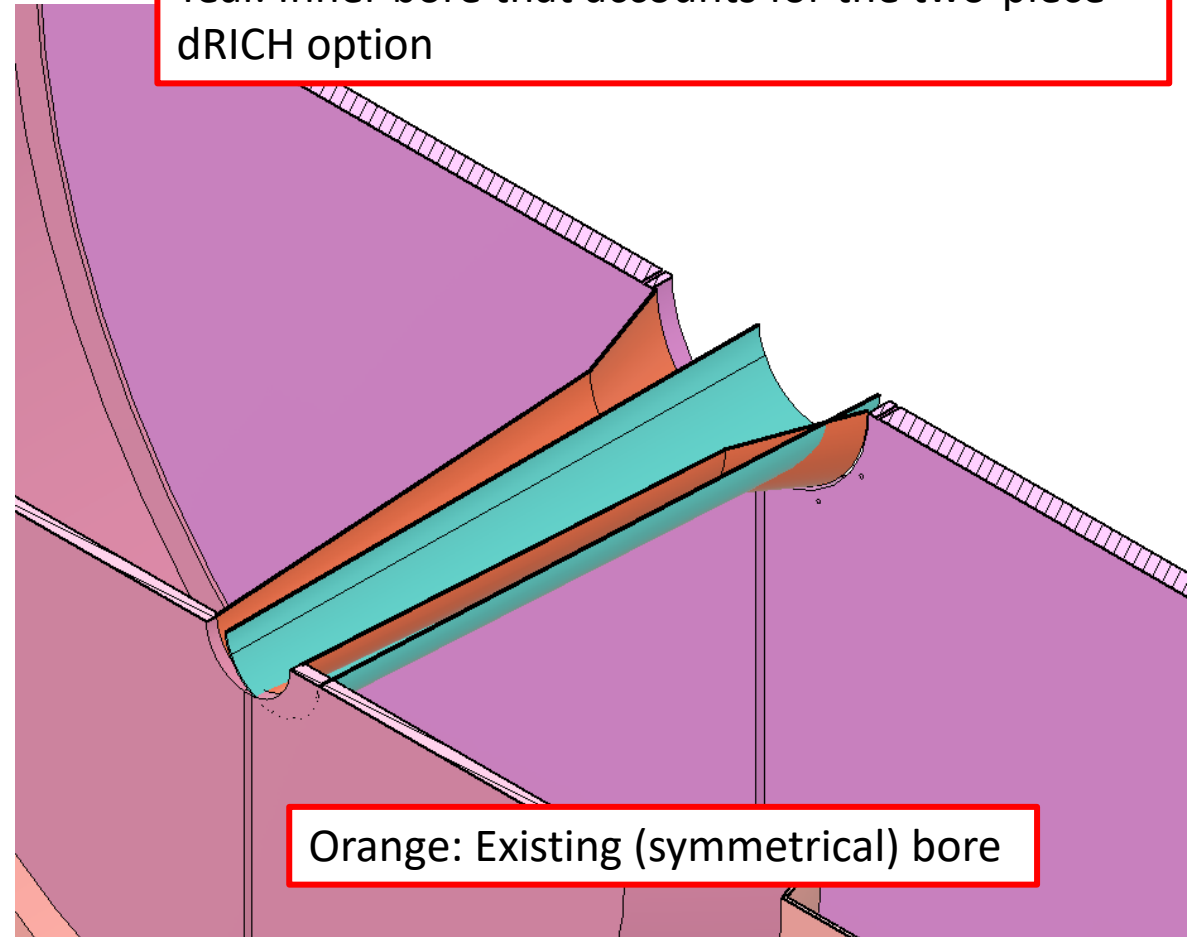

Orange: Existing (symmetrical) bore

This is the smallest bore available to us for the first option. It assumes that the dRICH is pulled out 150 cm from its nominal location (to clear services). It has an included 5mm clearance from the beam pipe at each location.

Option 2: New Inner Bore

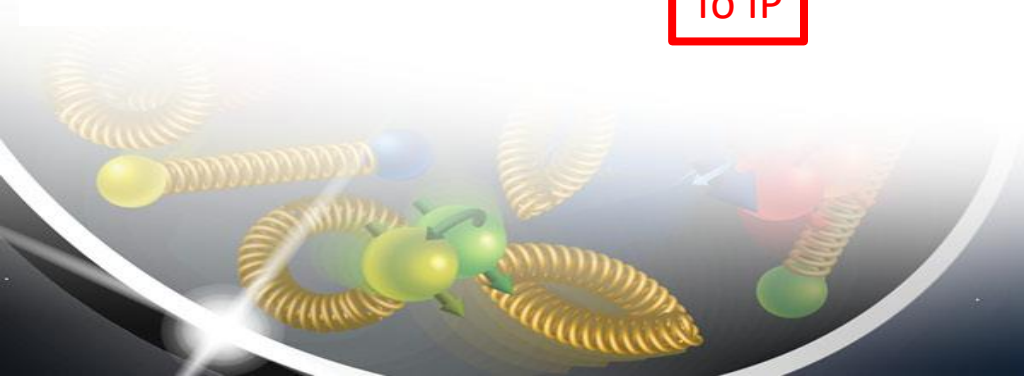
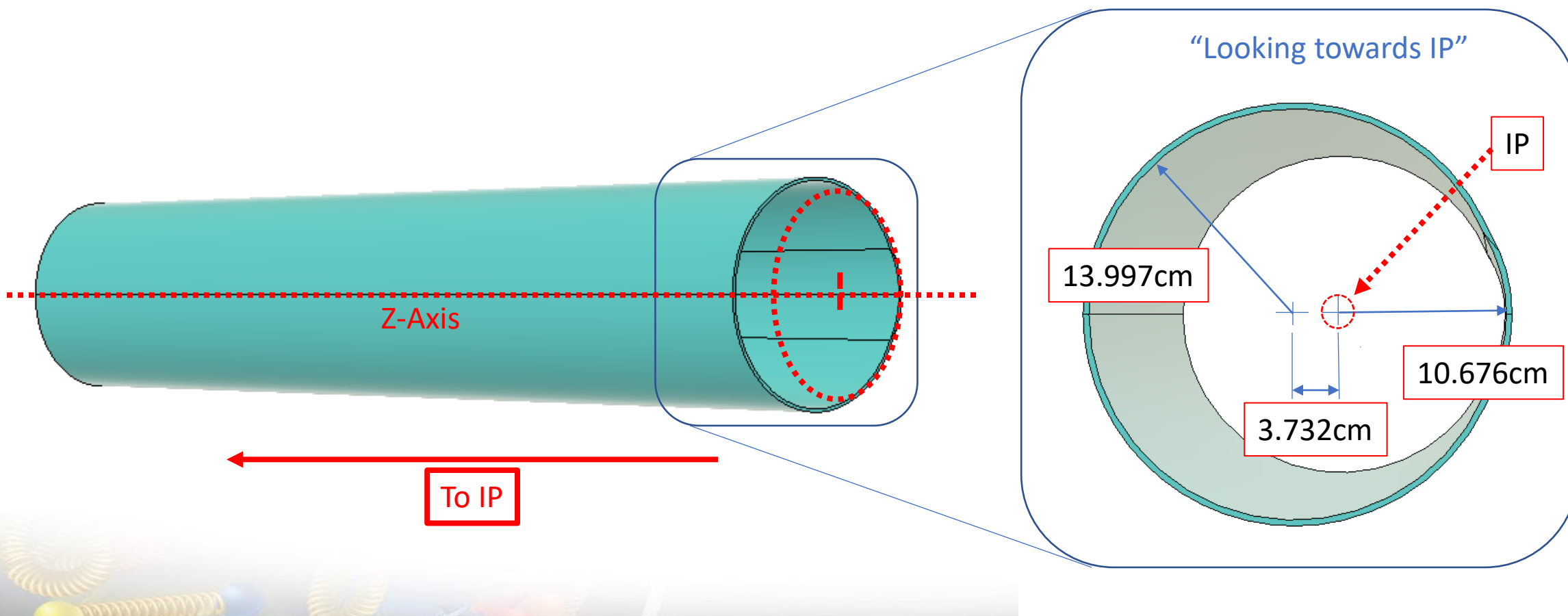

Comparison/Overlay

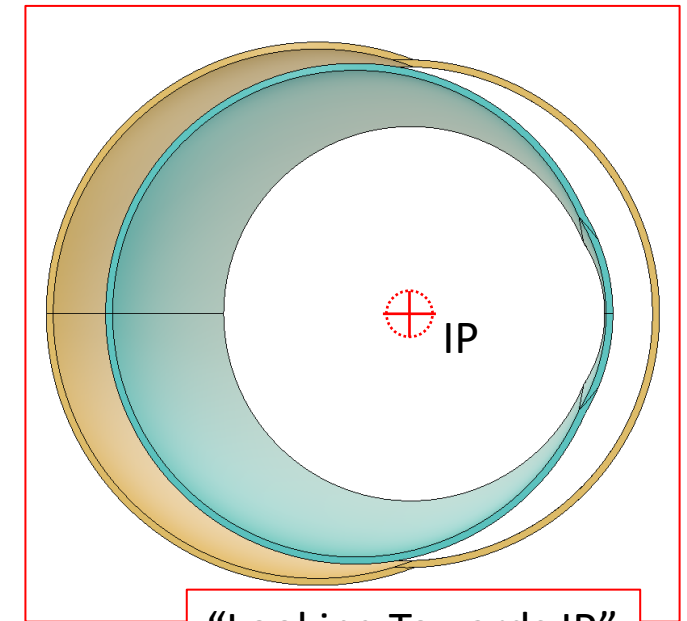
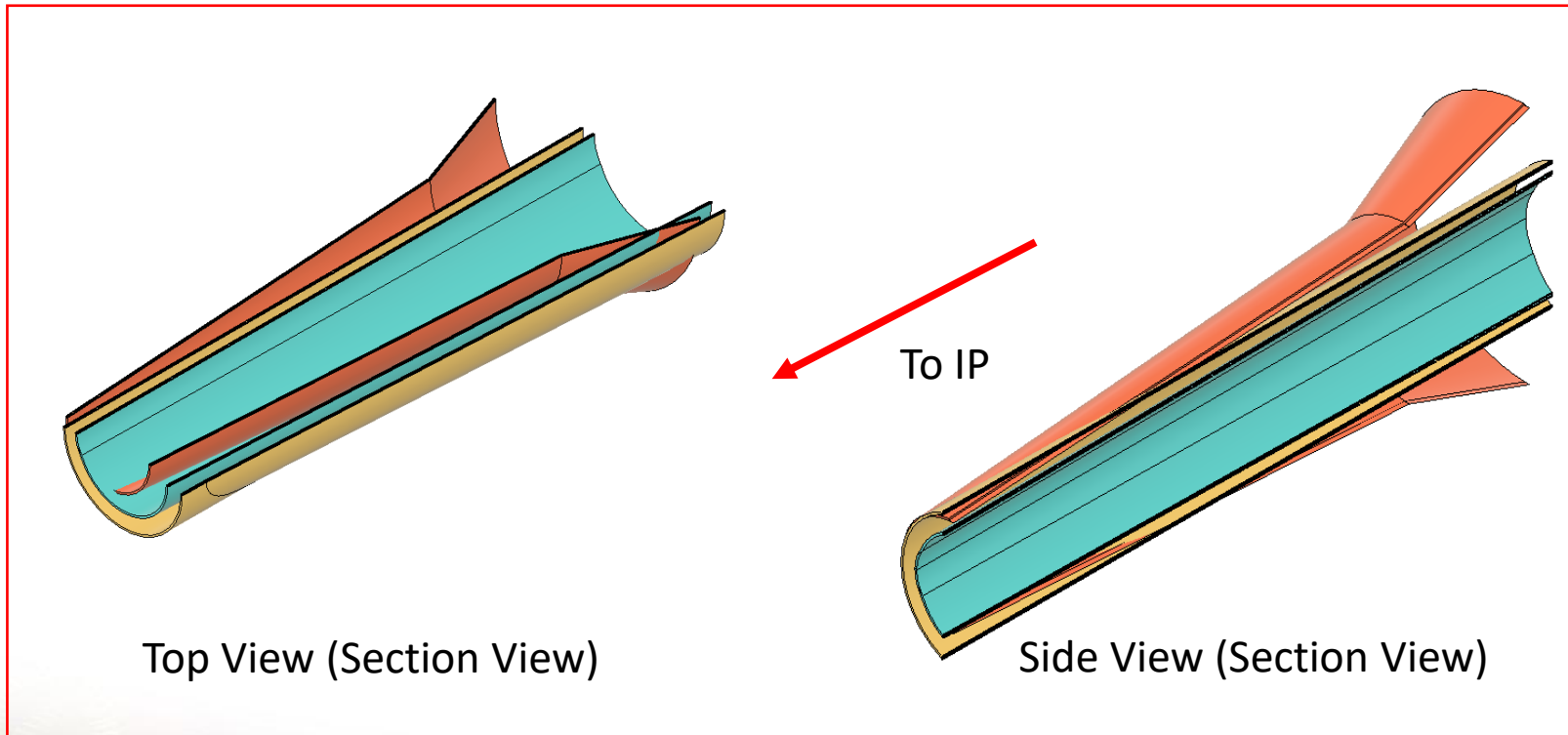

“Looking Towards IP”

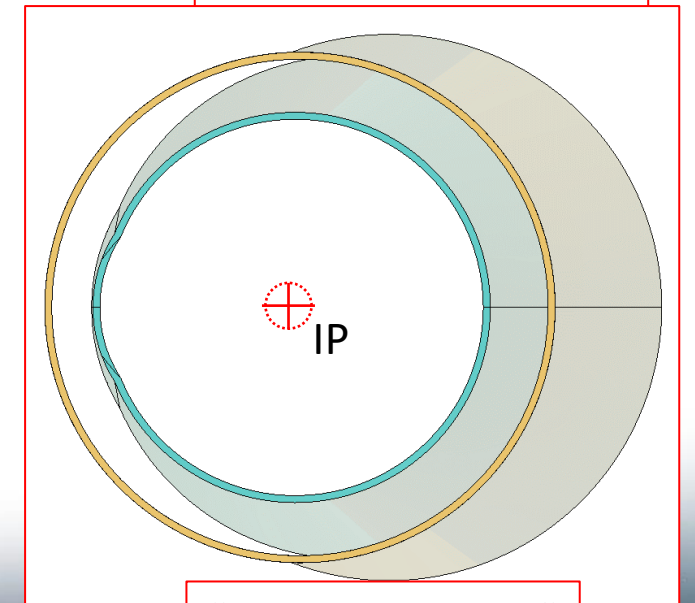

“Looking From IP”

Summary

- As expected, moving the flange to the front of the dRICH allows for the smallest bore overall. However, the dRICH will need a dividing wall for the split which may negate some of the advantages from the smaller bore.
- The CAD models for both bore options have been distributed to be used as simulation inputs to determine the best option.

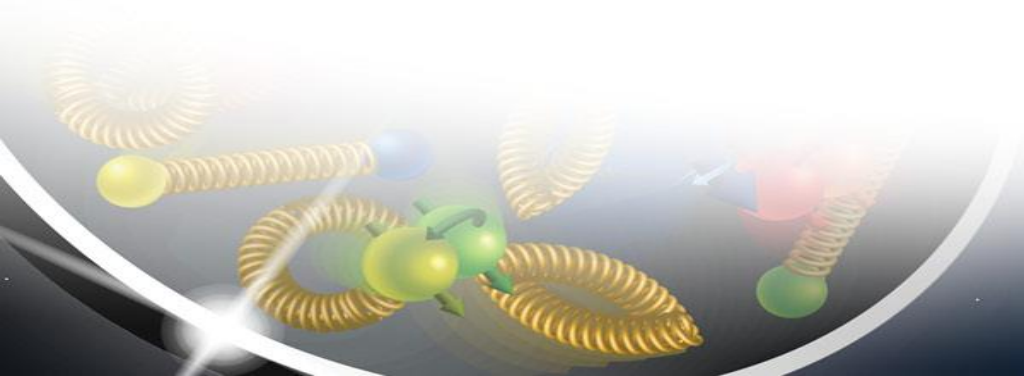

Additional Considerations for Splitting the dRICH

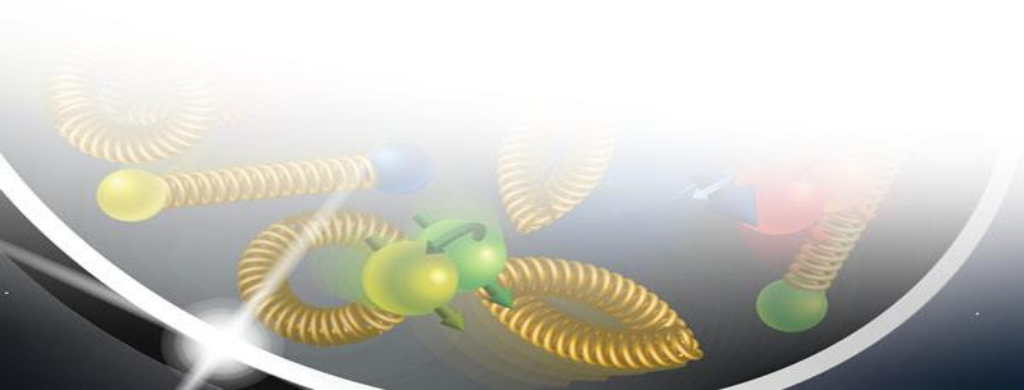

Motivation

- To determine whether the two-piece/splitting option might be viable, one must also consider the other mechanical impacts of splitting the vessel
- Preliminary and conservative estimates were established to parameterize the data needed as an input for the simulation
- These simulations will allow us to make the most informed decision going forward, or determine whether finer estimates are necessary

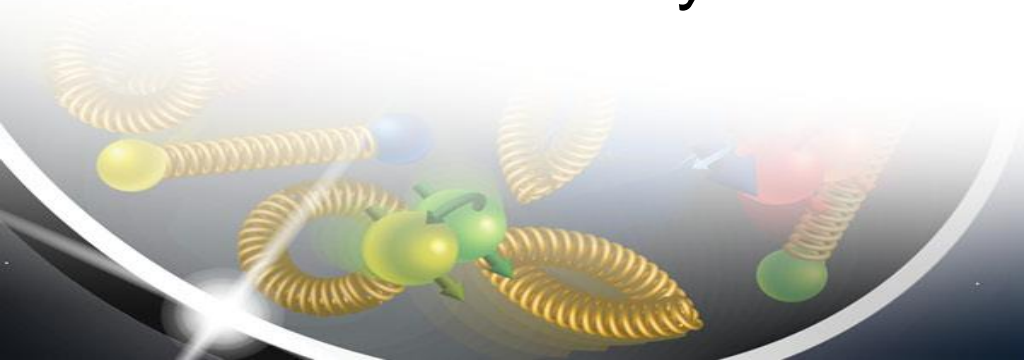

Modeled Split

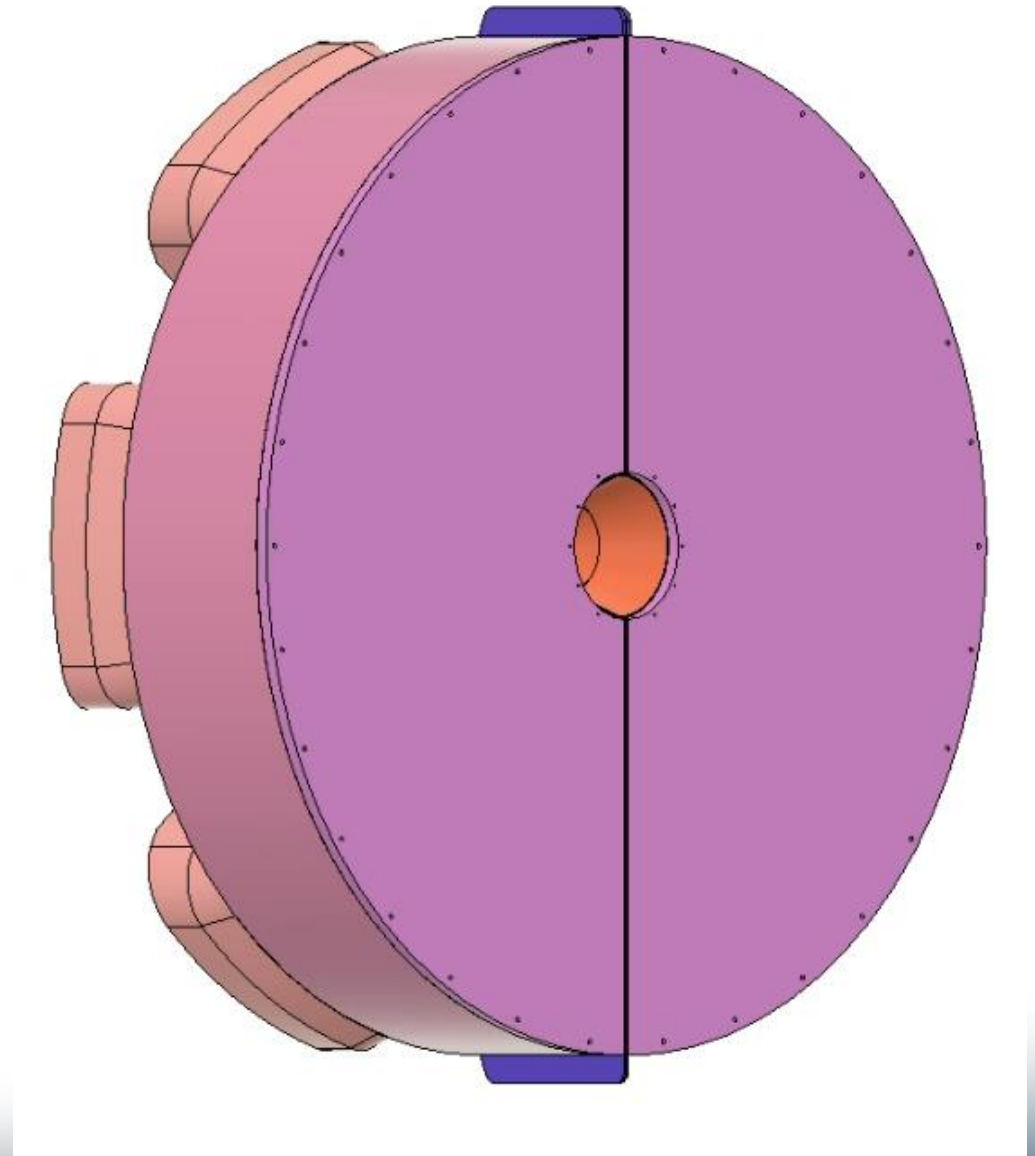
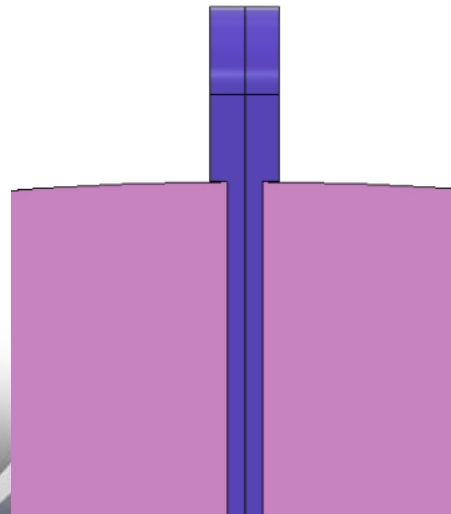
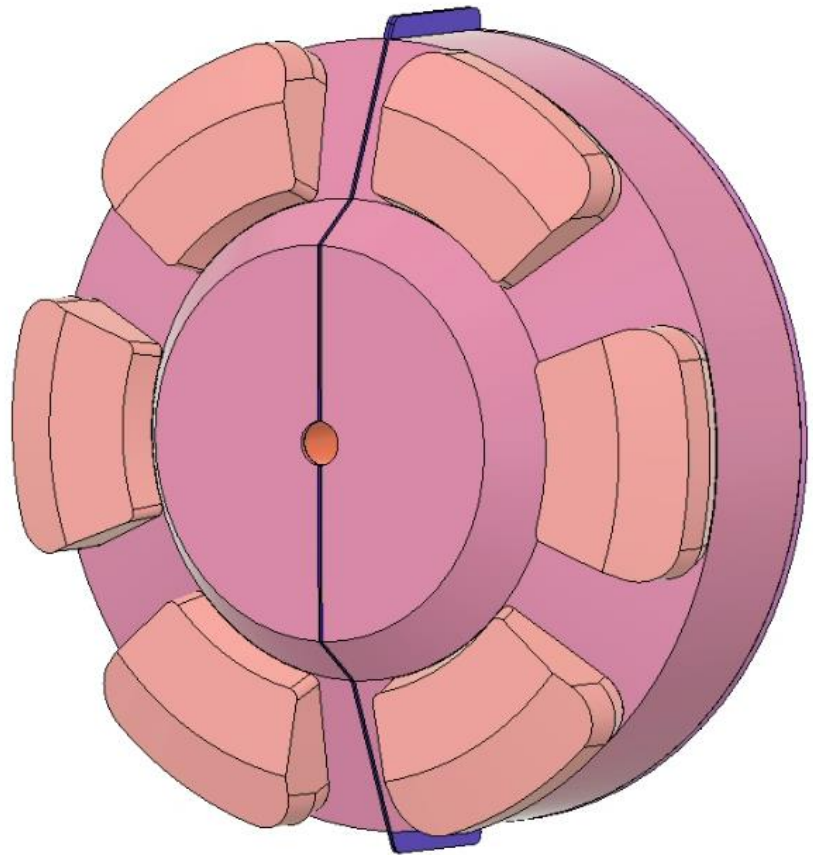

Thickness of the Dividing Wall

A full flange (stepped?) would be needed where indicated (red), with a sealing solution and a fastening method

- Rest of the vessel walls = 10mm thickness
- 10mm is a good conservative start with goals of minimizing the total thickness depending on mounting solutions.
- If we agree to fixture the vessel in a manner that minimizes deflection while halves are apart, we could make the walls much thinner.

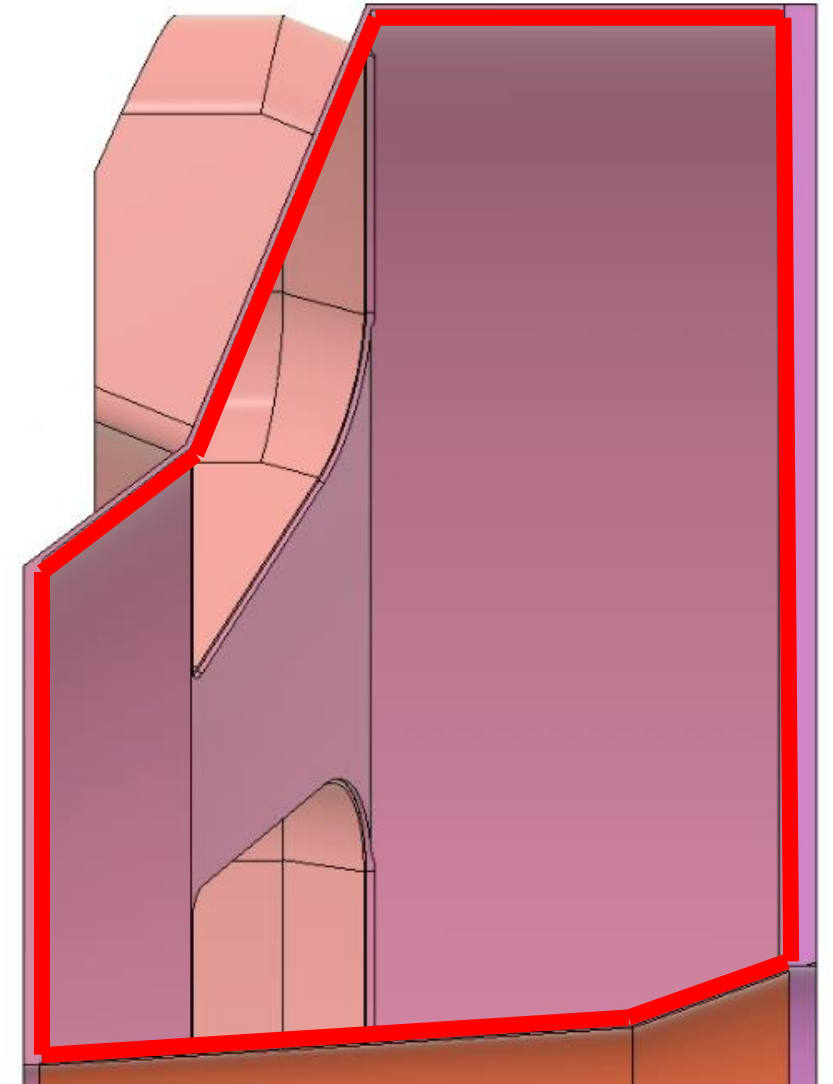

Dowel Pin Selection

- Since one of the dowel pins might be slotted in the direction of shear force, the most conservative case (to use for this estimate) would be that only one dowel pin would need to withstand the shear load produced by gravity.
- 304 SS has a yield strength of between 30ksi and 45ksi, meaning a FOS of ~3-4.5 depending on specific material properties and the anticipated shear load.
- Therefore, we could start with a 1/2" dowel pin in both the top and bottom flanges.

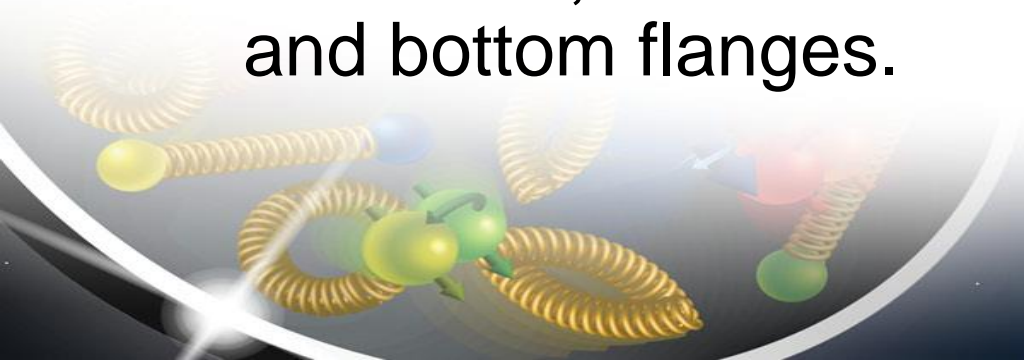

Dowel Pin Selection Cont'd

- Hardware size typically matches the dowel pin size
- Dowel pin length is typically four times the diameter
- Therefore, 1/2" Hardware Should be specified for the bolting flange
- Flange should be at least 2" tall
 - Total gap between OD of dRICH and inside of oHCAL
 - $195.25 \text{ cm} - 180 \text{ cm (radii)} = 15.25 \text{ cm} = 6''$
 - This gap is right in the middle of service routing so we should minimize the dimensions as much as possible
- Both flanges combined will be 2" thick

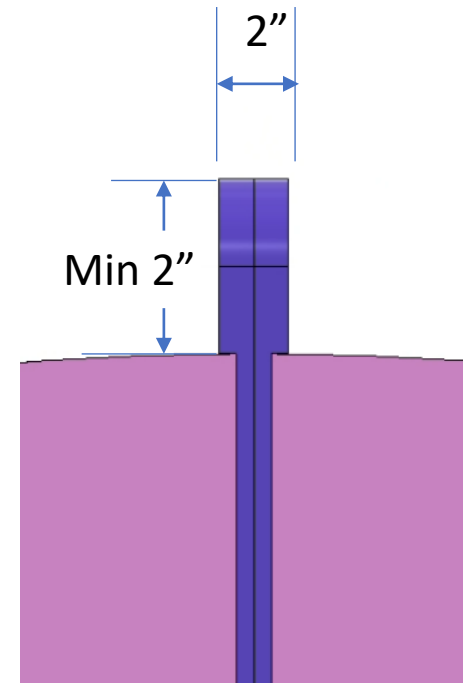

Designed Clearance

- Since there will be tolerances needed for manufacturing and assembly misalignments, a conservative estimate for the tolerance between the two halves should be established
- This estimate should be based around experience, so I discussed flatness tolerances that are typical on a dividing wall of this size with colleagues that manufacture and deal with similar pieces
- Based on these discussions, we should allow 2mm of designed tolerance between the halves.

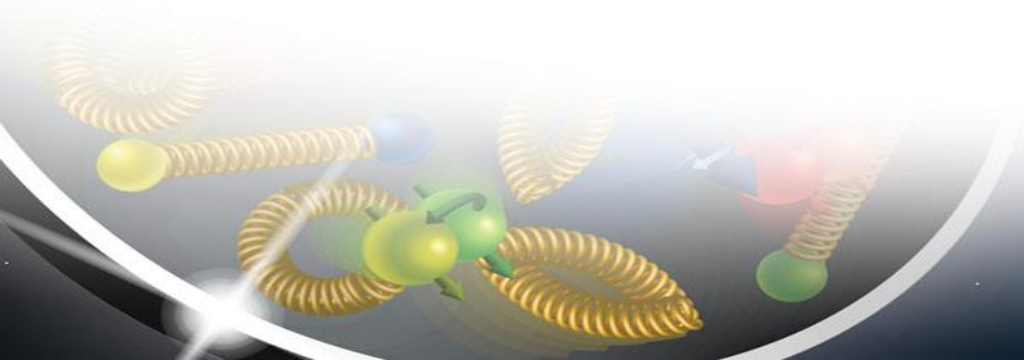

Additional Comments

- The thickness of these dividing walls is given as a conservative estimate:
 - The walls could be much thinner at the cost of structural integrity and a very accurate pressure system (keeping the halves equal)
- Since C_2F_6 is a greenhouse gas, it needs to be highly controlled:
 - The process of flushing the vessel with nitrogen could take up to a couple of weeks, which could mean that performing maintenance in the hall could still take nearly a month in just gas exchange time

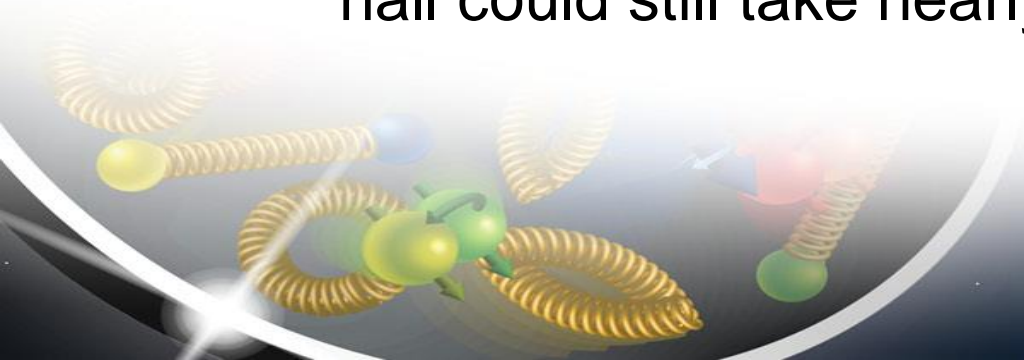

Dividing Wall for Split Option

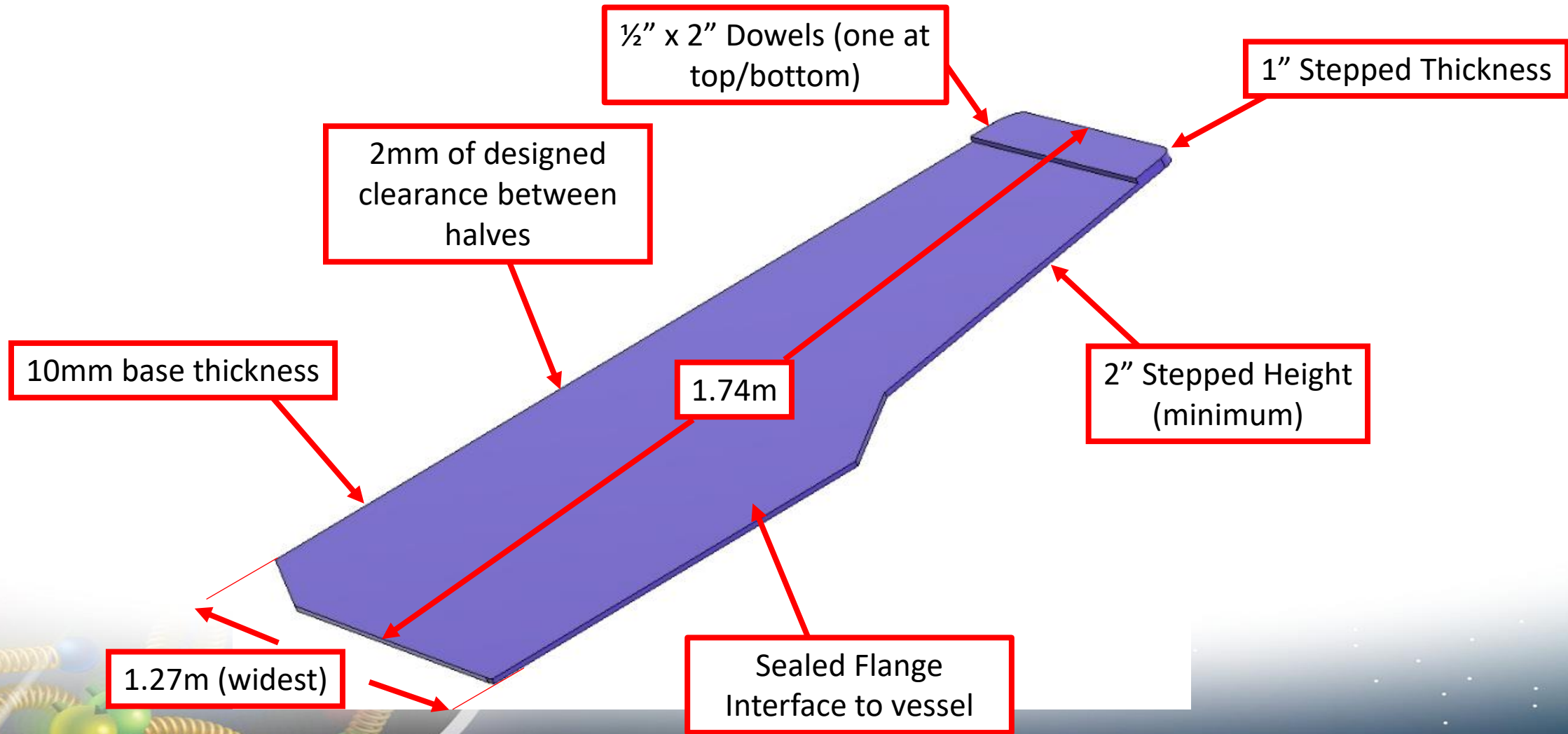

Questions?

