

# Spare DX Magnet Preparation and Installation

---

- DX and D0
- Splice cans damage
- DX end wiring
- DRX103 removal and inspection
- DRX114 spare preparation, steps and status
- Final steps
  - DRX Magnetic Measurement
  - DRX114 Installation and Testing
  - DRX103 Testing and Repair

# DX Magnet Assembly



DX above

D0 & Triplet Cryostat to the right.





# DX Magnet Assembly

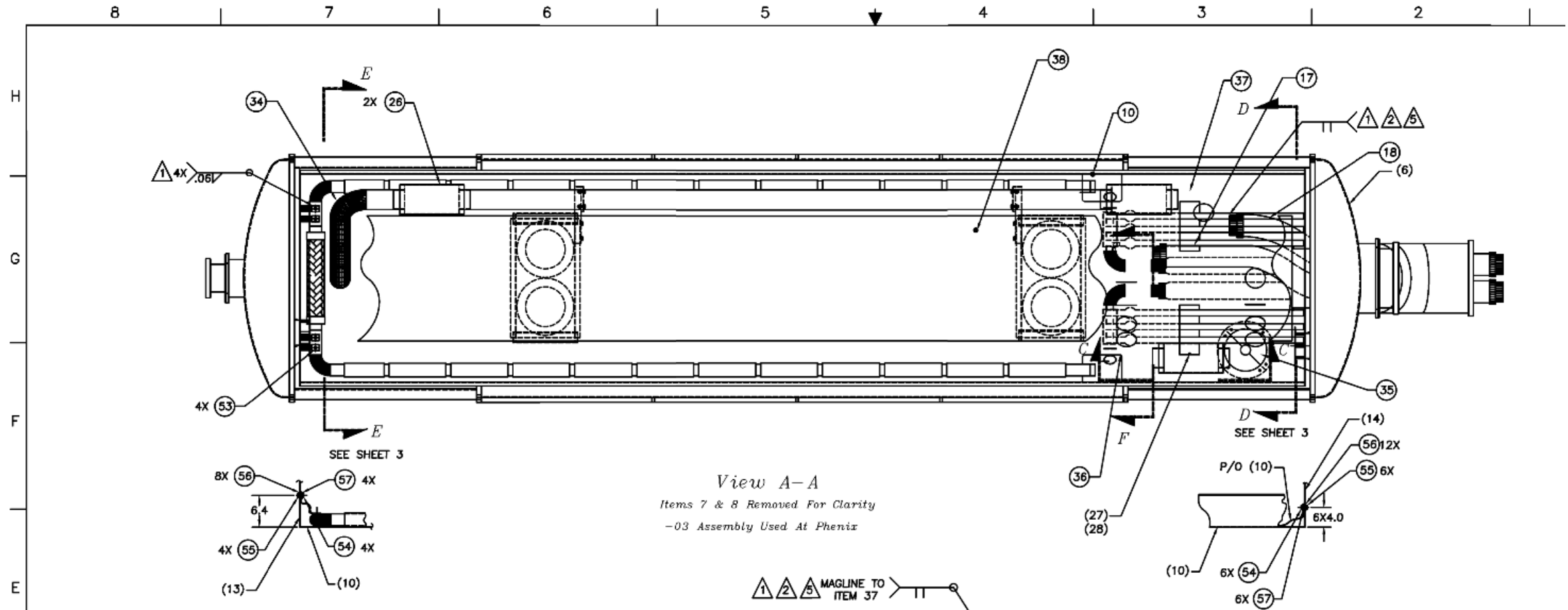

# DX Magnet Assembly

---



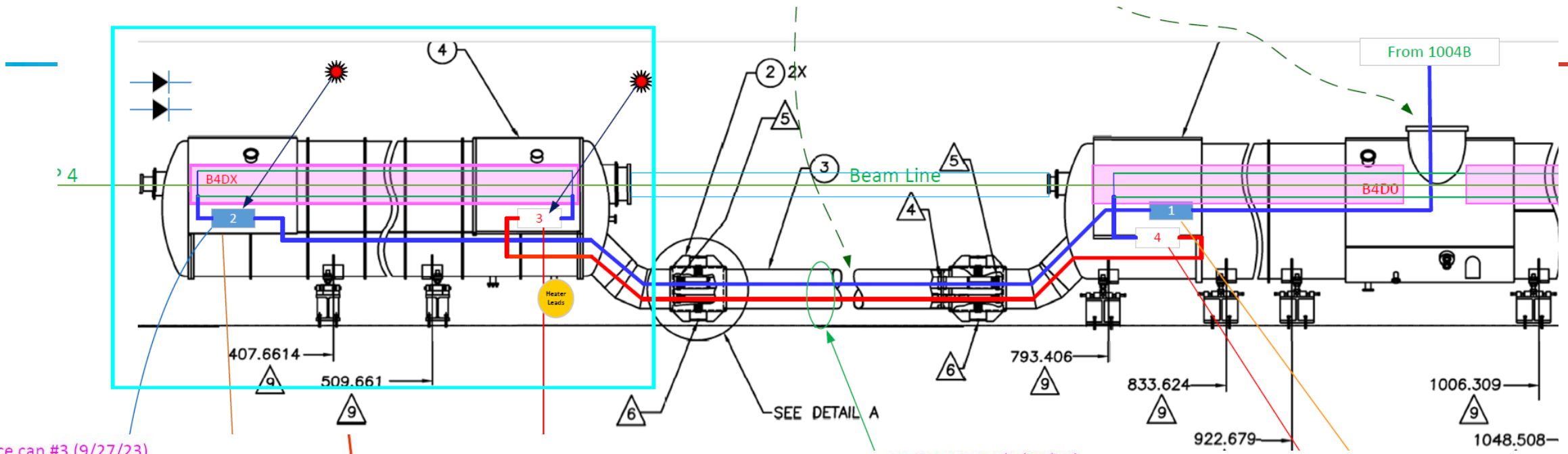

Splice can #3 (9/27/23)

Splice can #4 (9/25/23)

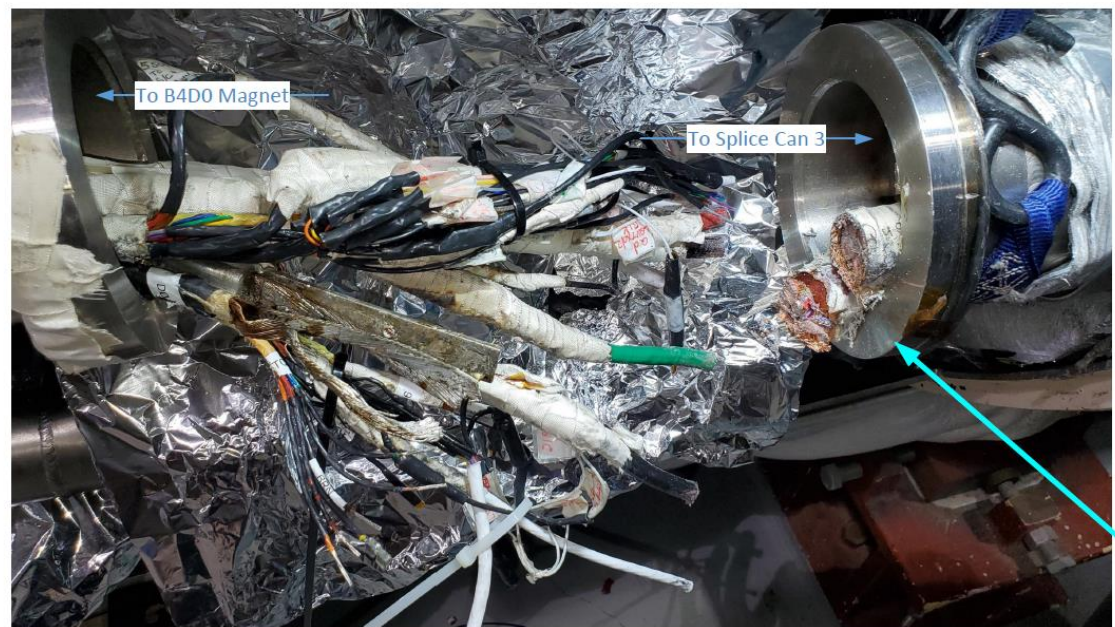

Splice B4DX magnet Preparation

# Splice Failures

1. Where is the problem – in the lead pots or the tunnel?
2. Opened valve box and lead pot first found the 12x150 damage.
3. Problem in CCB? DX? D0? Shorts beyond the VB.
4. First CCB splice access and opened between DX and D0. CCB to D0 “lead end”. (SC4)
5. Problem DX to VB side.
6. 2nd splice access CCB to DX “non-lead end” (SC3). Damage
7. 3rd splice access CCB to DX “lead end” (SC2). Damage
8. 4<sup>th</sup> splice access CCB to CCB valve box (SC1). No Damage
9. The CCB to D0 lead end splice has been completely disassembled for CCB replacement (SC4). This allowed detailed inspection and testing of the D0 – no issues.



# Repair Plan

---

1. The DX magnets end connections/end volumes are not accessible when the DX is installed in the cryostat. The DX had to be removed and repaired elsewhere.
2. There is a full DRX114 DX spare magnet assembly that was successfully vertically cold tested and trained to operating current. **(25 years ago)**
3. The DRX114 was inspected and tested warm. It was stored well.
4. The warm magnetic measurement of the DRX114 is being repeated now.
5. The spare was not wired to a left or right configuration.
6. All necessary wiring for the spare was found and the technician who wired the DX and the DX engineer are still in the Superconducting Magnet Division – they provided full support.
7. Damage to the DRX103 magnet was not apparent; but, **unknown**. (140 Turns, 6300A)
8. The DRX103 would require additional time to repair due to removal of old damaged bus.



# DX and D0 lead end wiring

- The DX uses cable connections for magnet to CCB interconnects on both ends.
- The RHIC arcs use hard bus magnet to magnet interconnects.
- The D0 uses cable connections for magnet to CCB interconnect on one end.
- 2 out of 3 magnet cable to CCB connections failed, both DX connections.
- # 3 on D0 was opened, inspected, and found to be OK.
- The CCB to CCB connection between the failed DX connections and the valve box was opened for inspection and found to be OK.

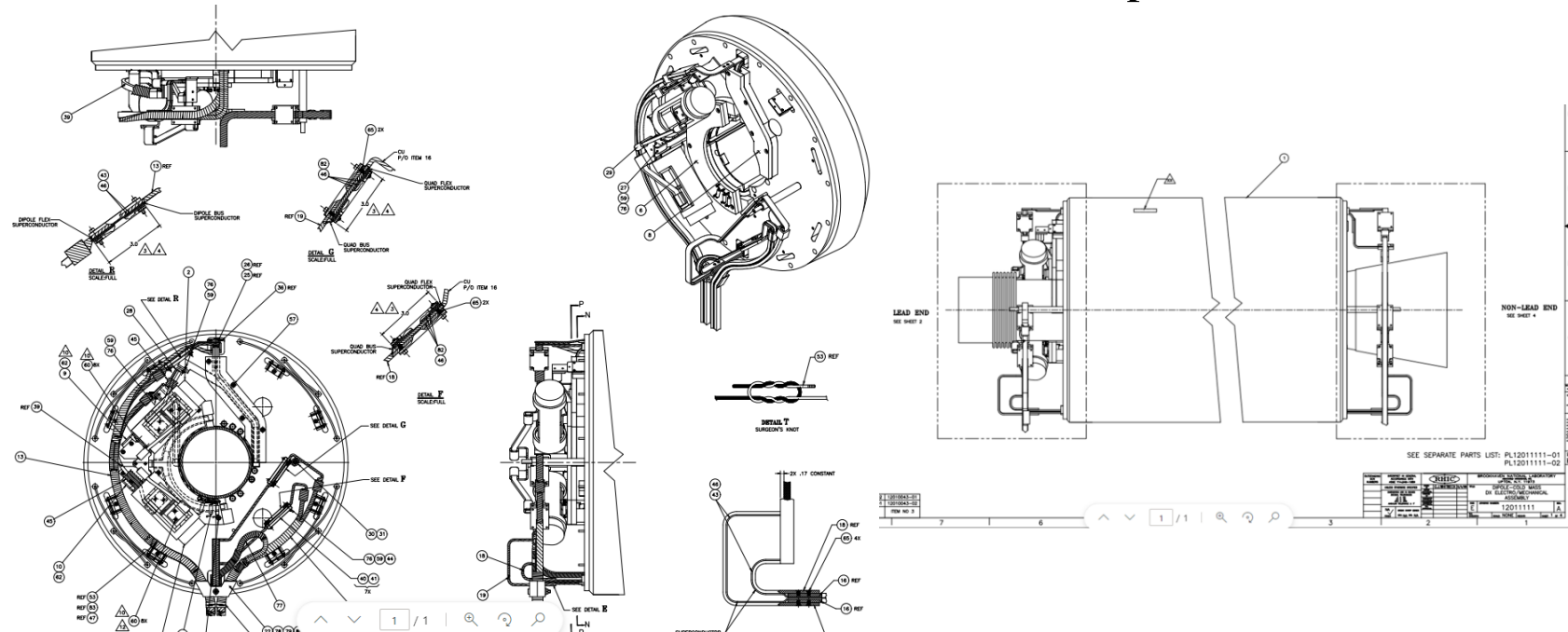
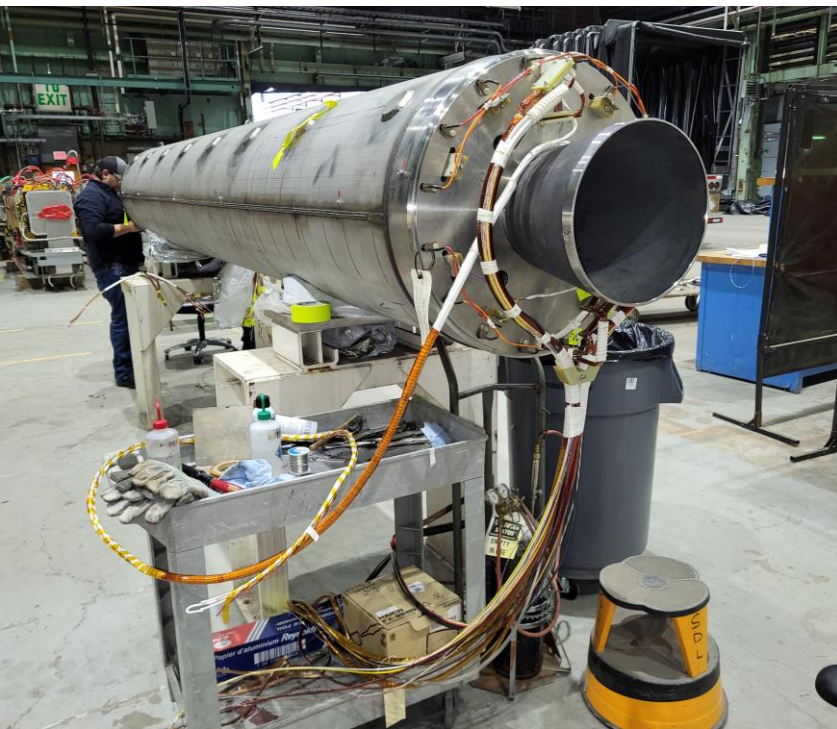
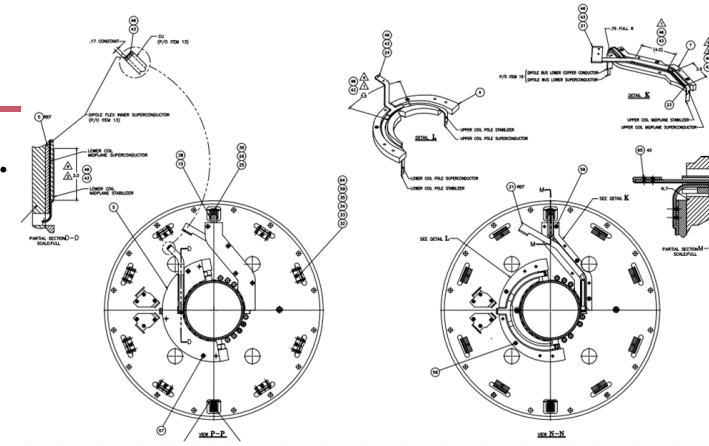

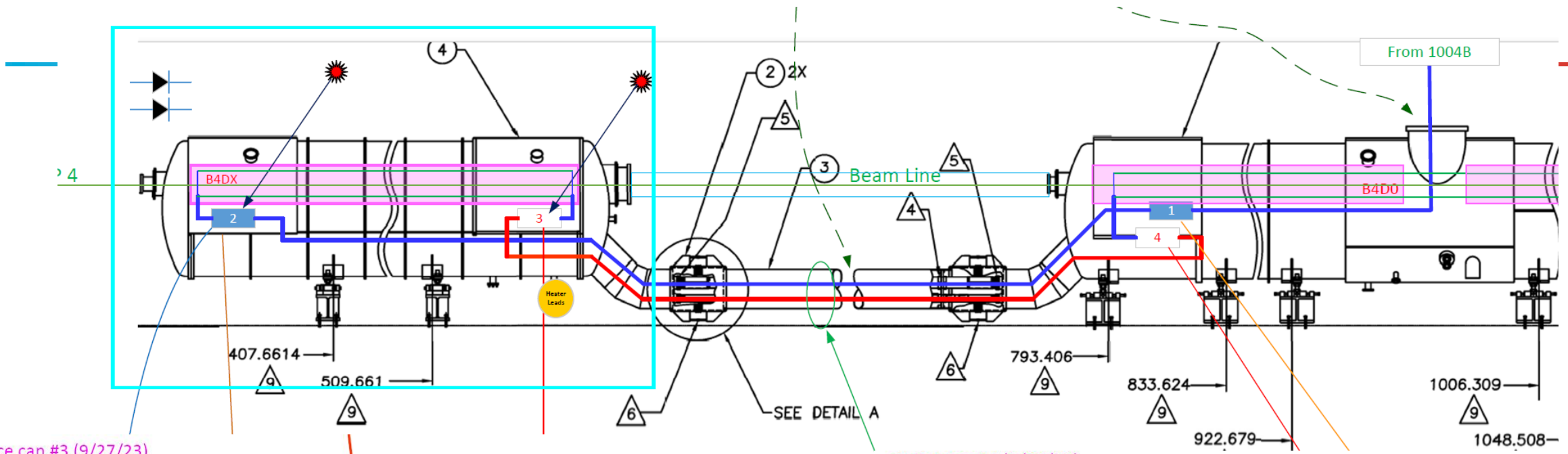

Splice can #3 (9/27/23)

Splice can #4 (9/25/23)



Splice B4DX magnet Preparation

# Arc Magnet Interconnect Comparison

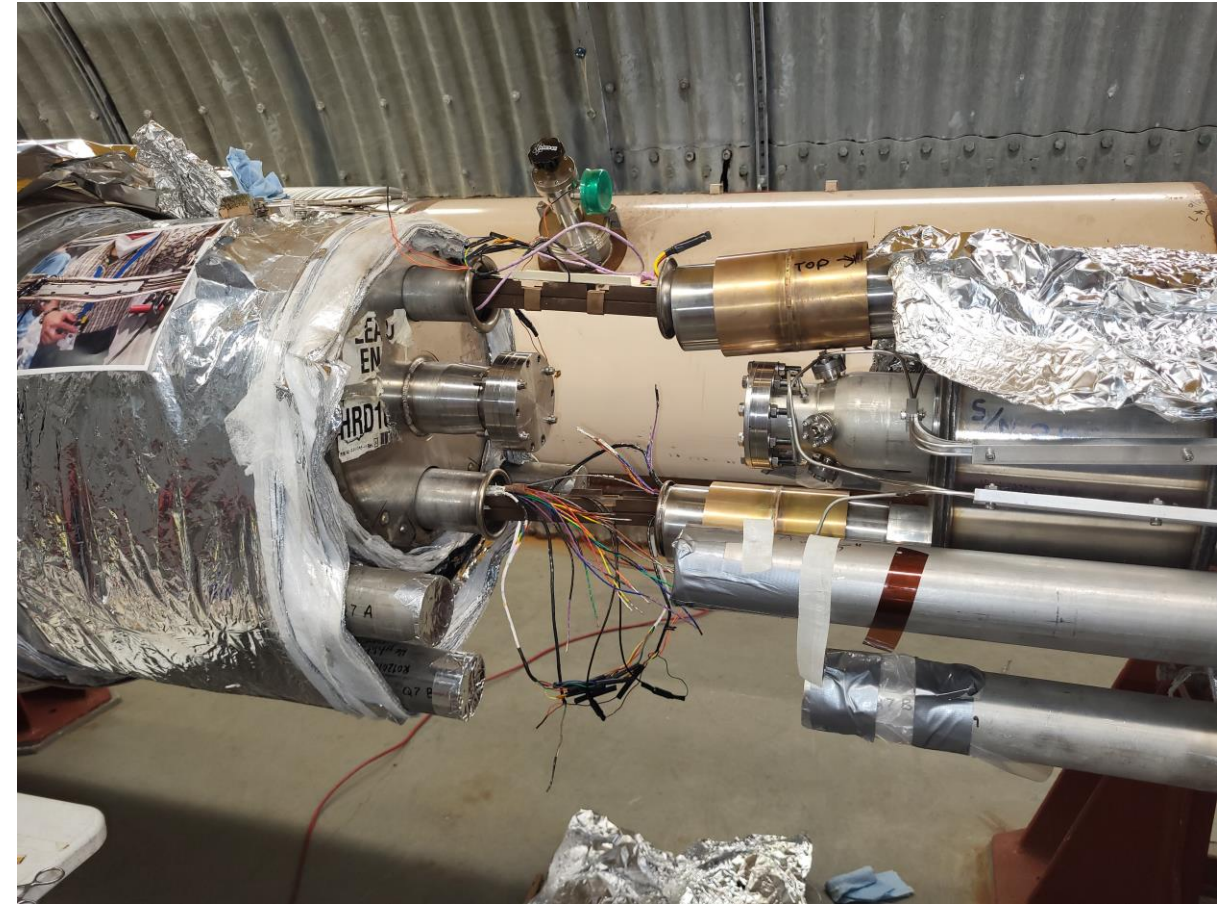
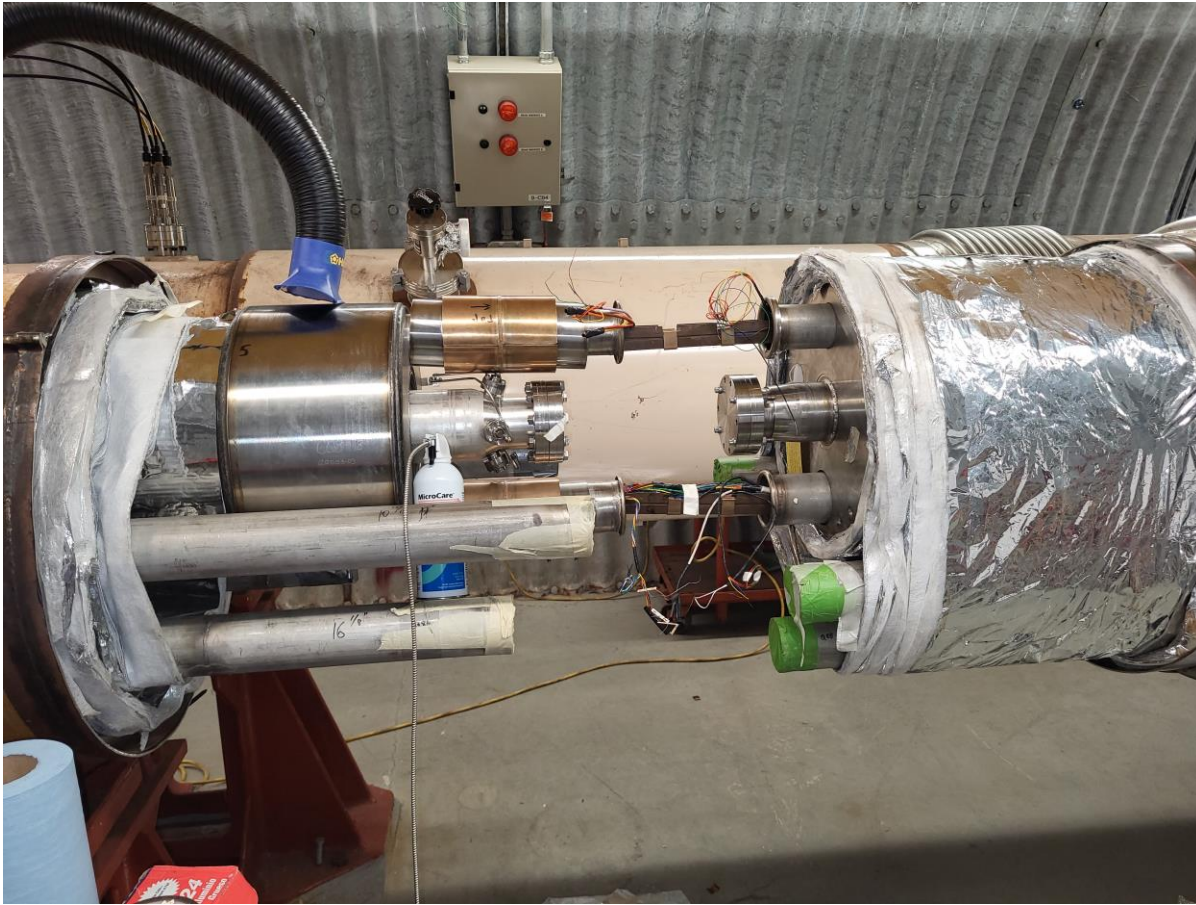

Typical Magnet to Magnet Bus Interconnect

# Removal

- Magnet Cold Mass Assembly Surveyed
- Center Beam Tube Removed (DX is a “warm bore” magnet)
- Rigging A Frames Installed, DRX103 Moved to 912
- End Volumes Removed
- Spare DRX114 Located and Moved to 912



# DRX003 End Volumes Removed



# DRX003 End Volumes Removed



- < Lead End (End closest to the IR)  
NonLead End (Closest to D0) >
- Ends removed for inspection
- No obvious or additional damage.
  - Guide to prepare the spare.
  - For more detailed testing.
  - Rebuild as a spare.



# Spare DRX114

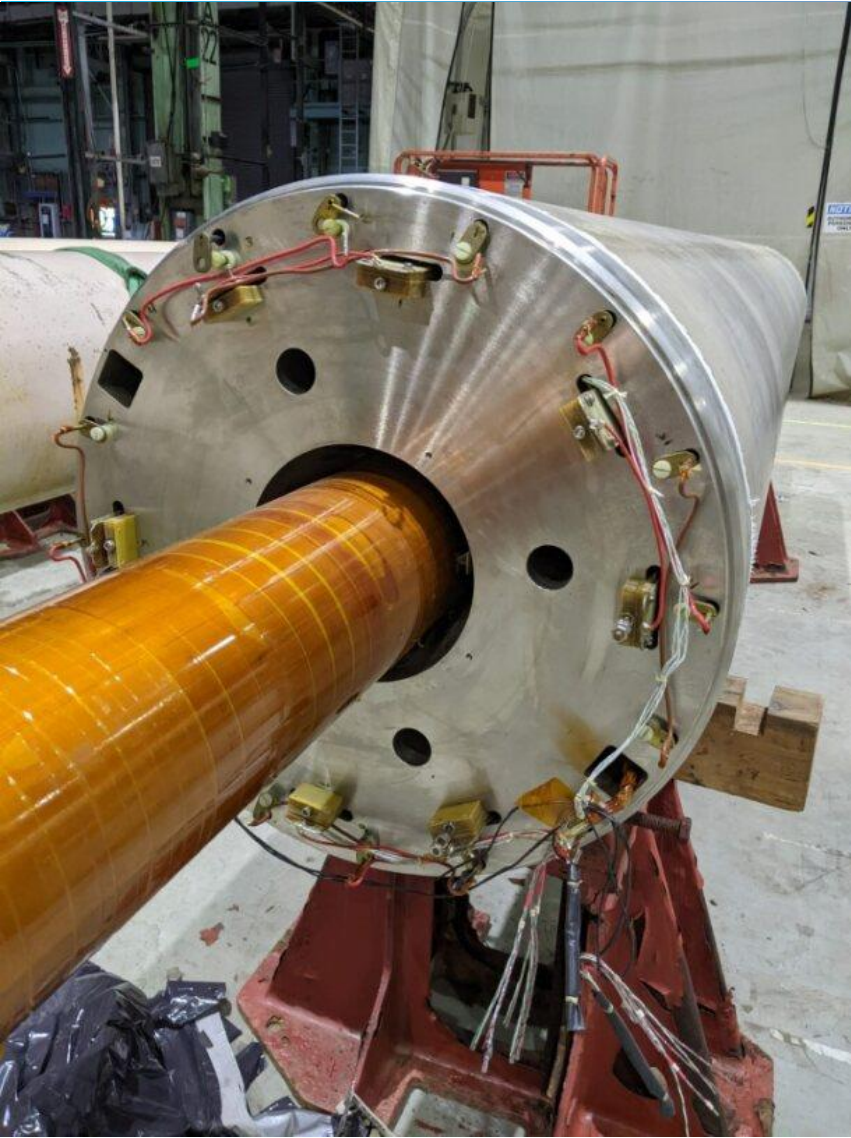

# DRX114 Wired and Electrically Tested

- Central Interconnect Bus Installed (spare assemblies)
- Both end volumes wired (spare parts)
- All cables electrically tested and marked for final interconnect
- Ready for End Volume welding

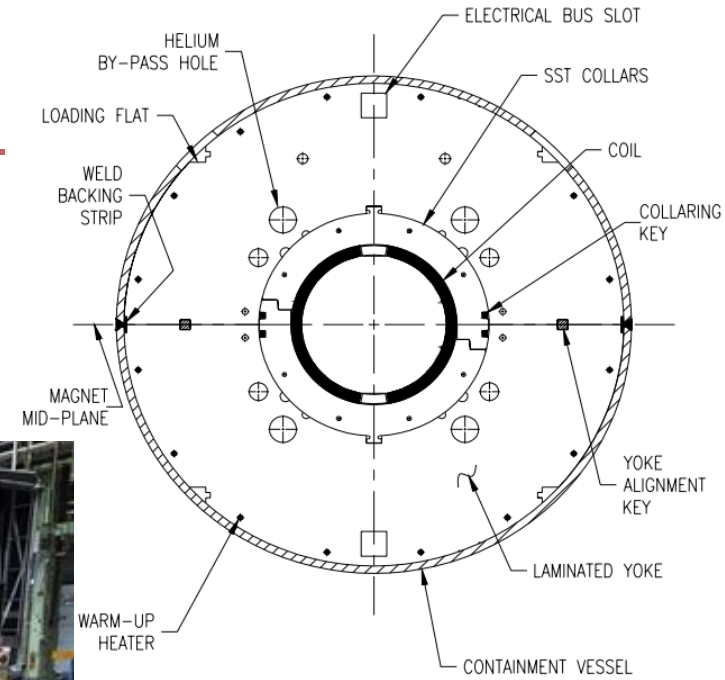

Spare DX Magnet Preparation and Installation



# DRX114 Wired and Electrically Tested

- Magnet Pre-Surveyed and Fiducials Added
- End Volumes Welded On and Vacuum Leak Checked
- Electrically Tested Again
- Moved for Magnetic Measurement for Vertical Field
- Final Pressure Test When DRX114 is Installed in RHIC



# DX Magnet Measurement Set-up

Final Electrical Test and then Magnetic Measurement



# Tunnel Preparation

Replace damaged CCB DX to D0 and splice.

Cut CCB on lead end – Splice at new splice can.

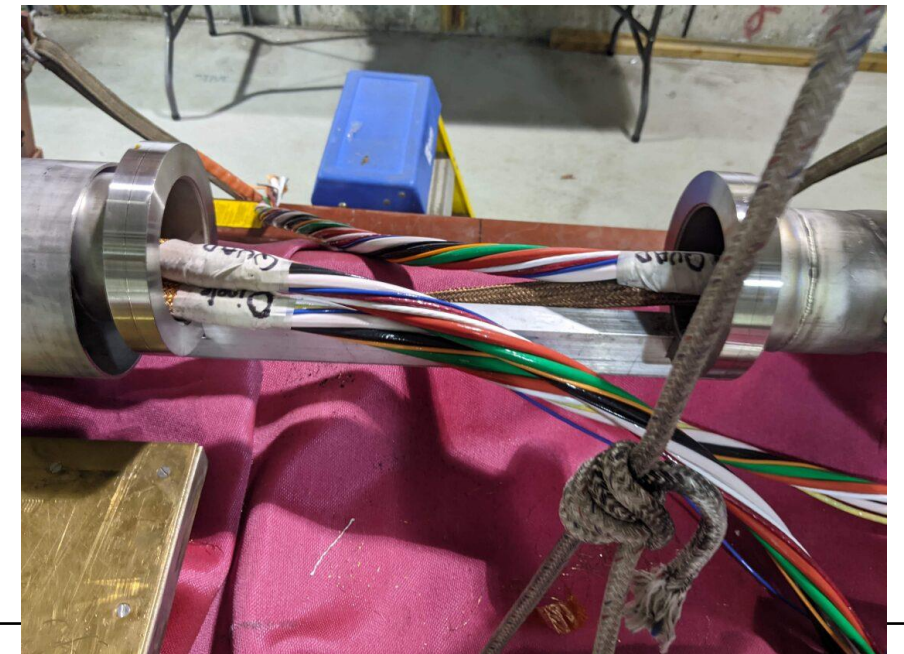

# Final Steps for DX Magnet Installation

---

1. Complete and Compile Magnetic Measurement Data for Survey
2. Complete 2 splices in Tunnel and Electrically Test
3. Install DRX114 on the Cryostat Stands and Survey
4. Complete Lead end and Non-Lead end DX bus to CCB splices and Electrically Test
5. Connect DX heater wires
6. Close up M line splice cans, electrically test, and pressure test RHIC arc sector and valve box.
7. Start RHIC arc sector 04 helium scrub (valve box work complete).
8. Install DX vacuum chamber and DX to D0 vacuum chamber and bakeout
9. Close up DX, D0, (and Valve Box) Cryostats

# Summary

---

The DRX114 is a tested and ready spare that will be installed shortly.

The preparation was done with experienced technical leads and available spare parts.

The DRX114 is on the final stage of preparation for installation.

The tunnel preparation work is near complete.

The DRX103 magnet bus will be disassembled, electrically tested, magnetically measured warm, and then be rebuilt as a spare.

# Thank You

---

Questions?