

Tracking performances of the ePIC detector (24.06.0)

Shyam Kumar*, Annalisa Mastroserio, Domenico Elia
INFN Bari, Italy



Istituto Nazionale di Fisica Nucleare

ePIC Tracker (24.06.0)

epic_craterlake_tracking_only.xml

300k π^- each with momentum (0.3 0.5 1.0 1.5 2.0 3.0 4.0 5.0 8.0 10.0 15.0 20.0)

Software version with updated material map

```
shyam@shyam:~/eic/epic$ git describe --tags --abbrev=0
```

24.06.0

```
shyam@shyam:~/eic/EICrecon$ git describe --tags --abbrev=0
```

v1.14.0

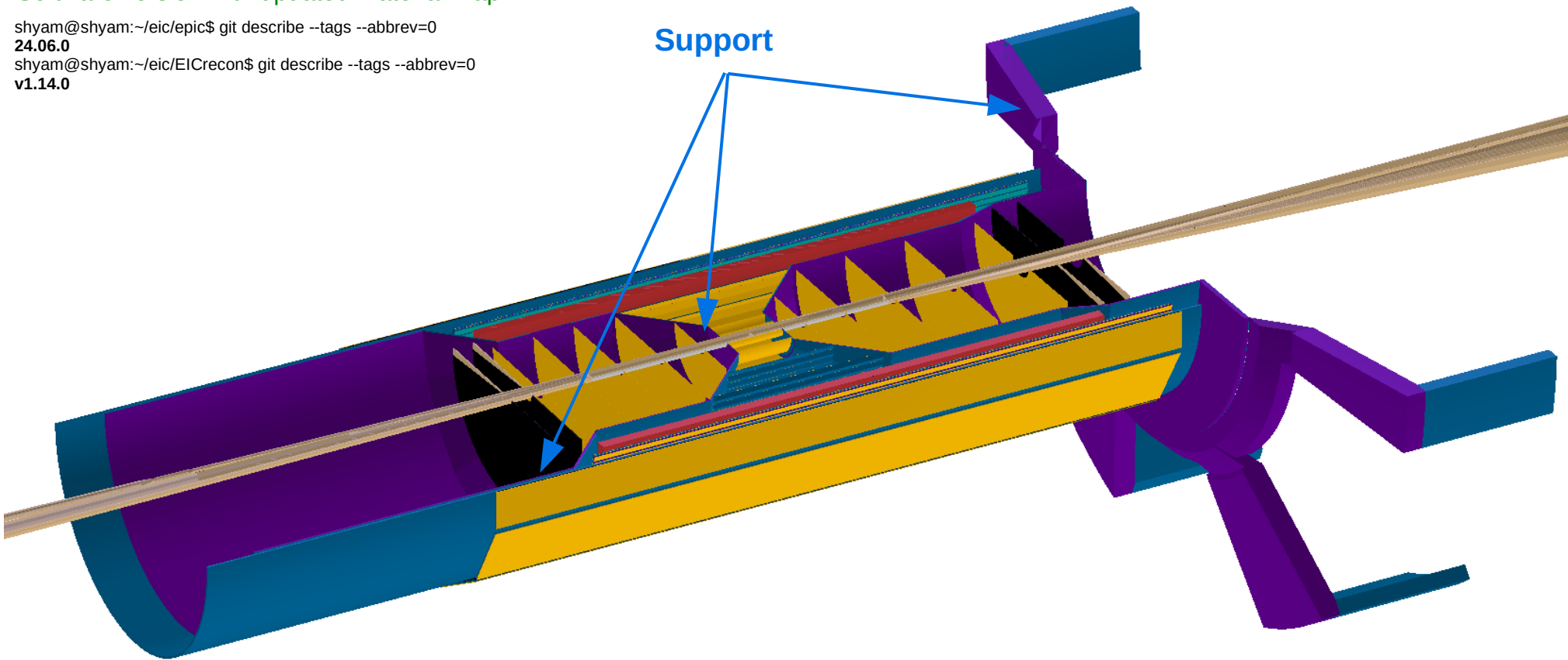

Material Budget (ePIC 24.06.0)

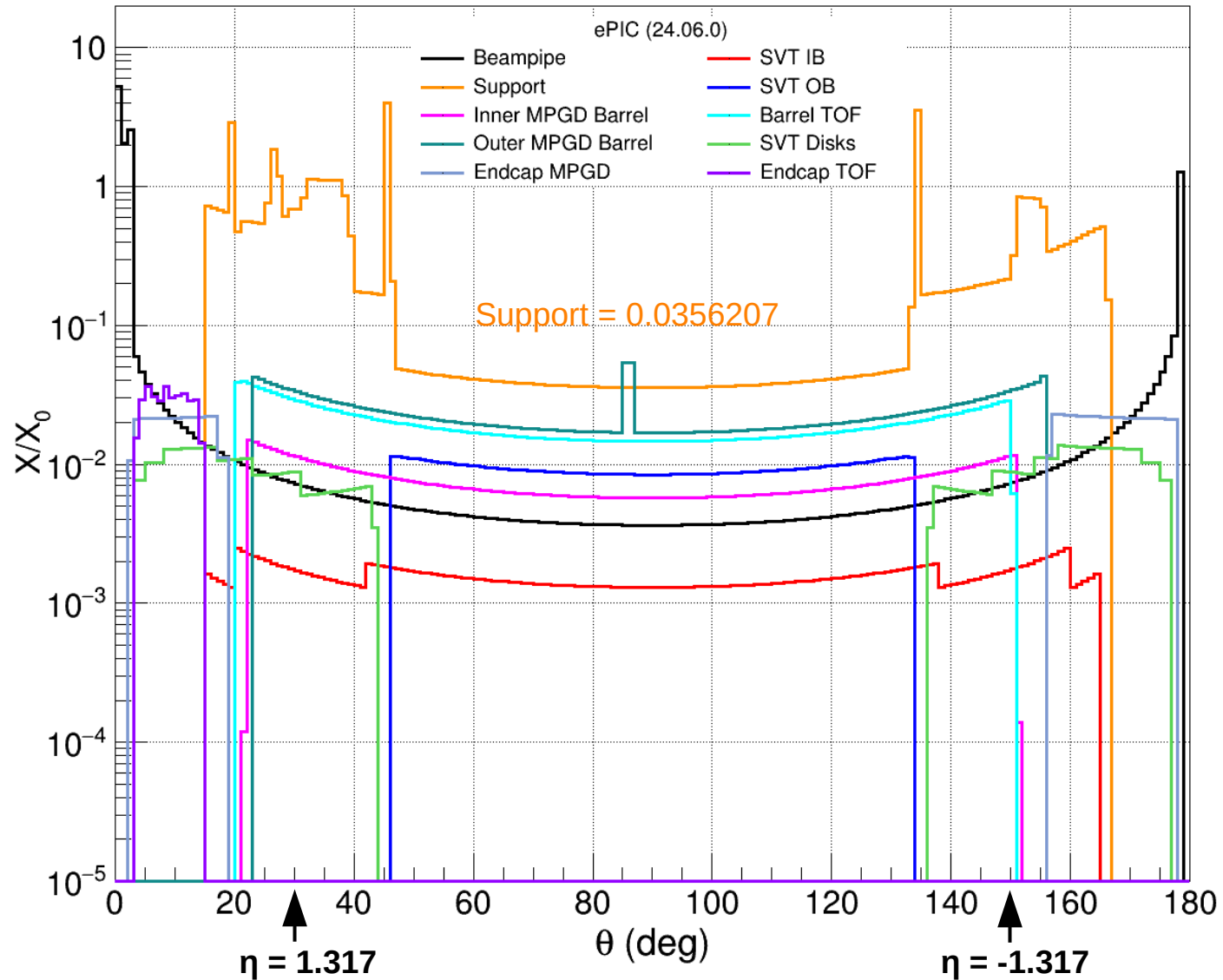

Geometry and Momentum Resolutions (Real Seed)

Different η regions

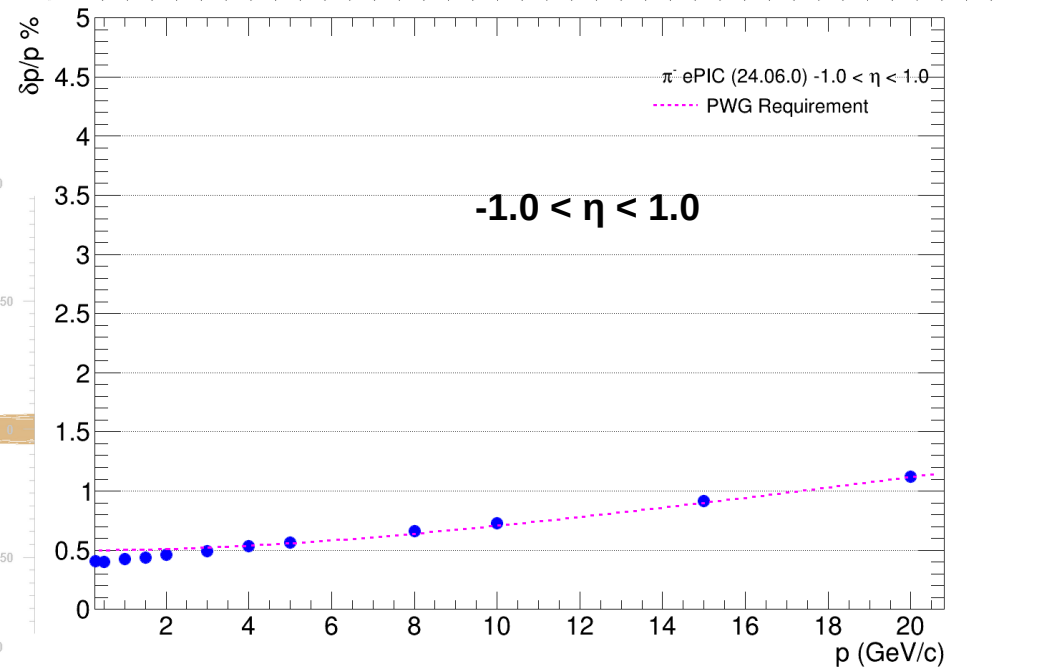
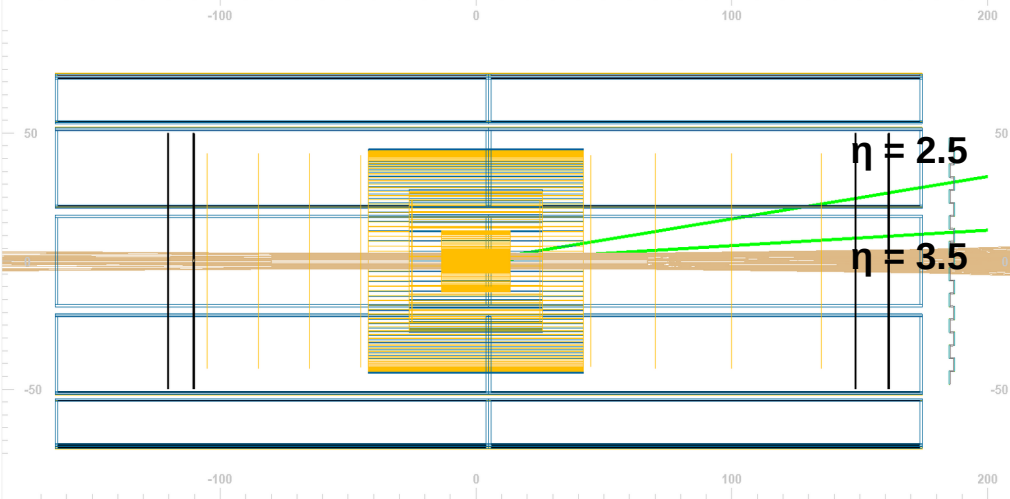
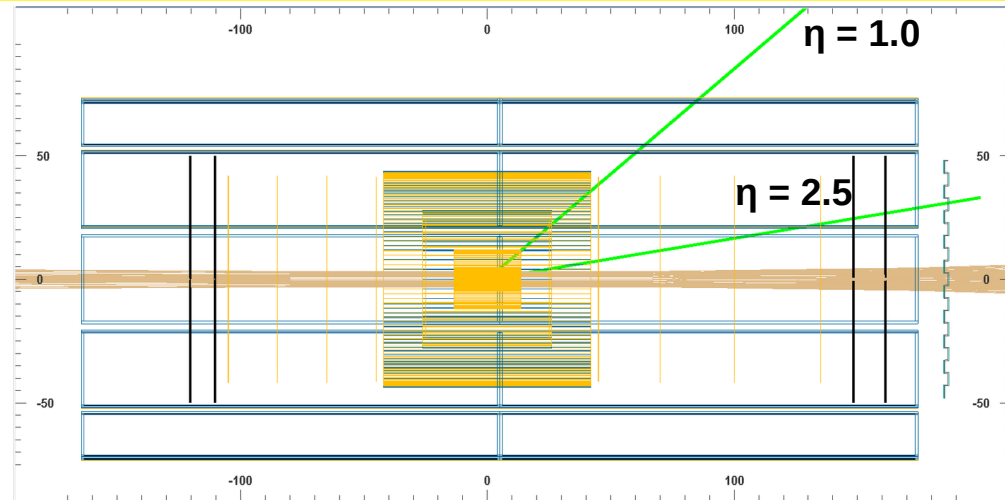
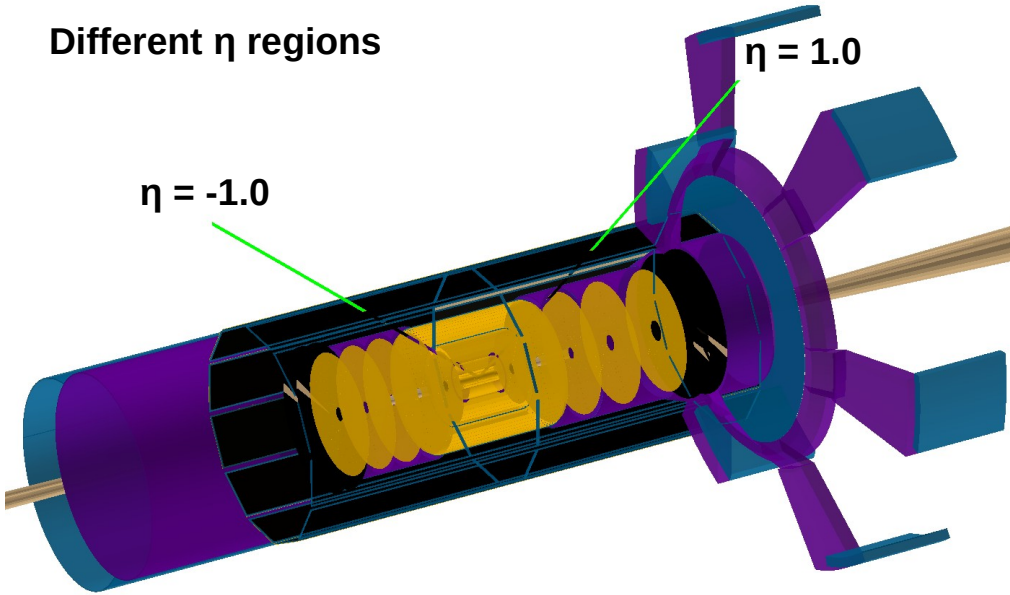

Momentum Resolutions

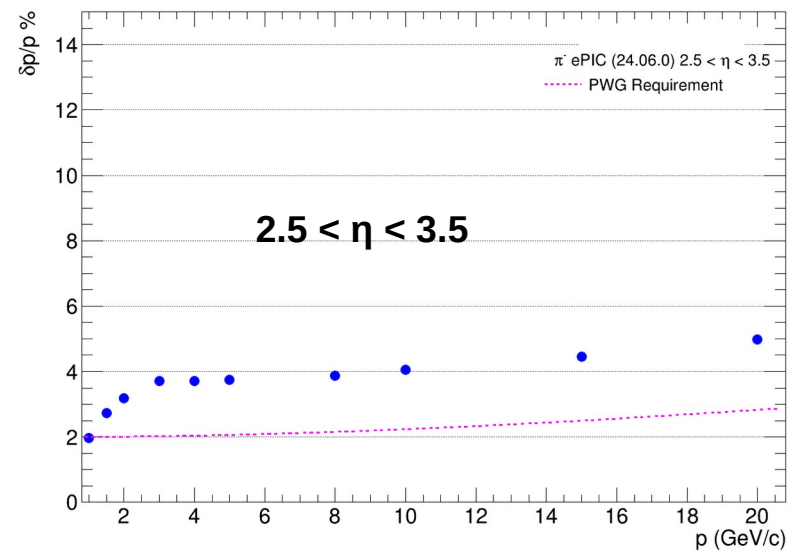
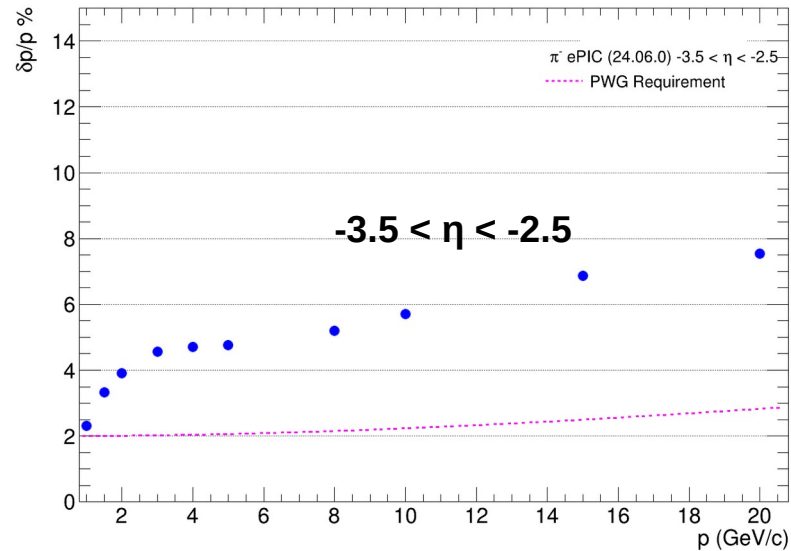
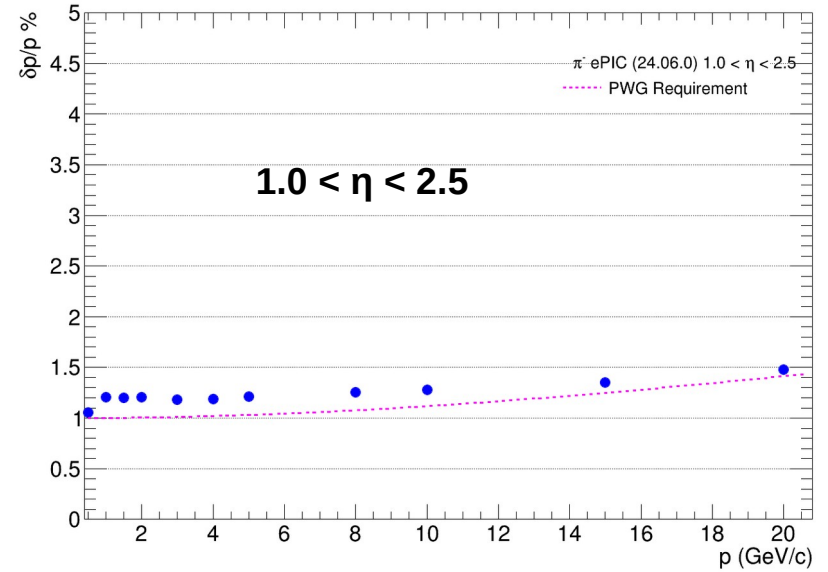
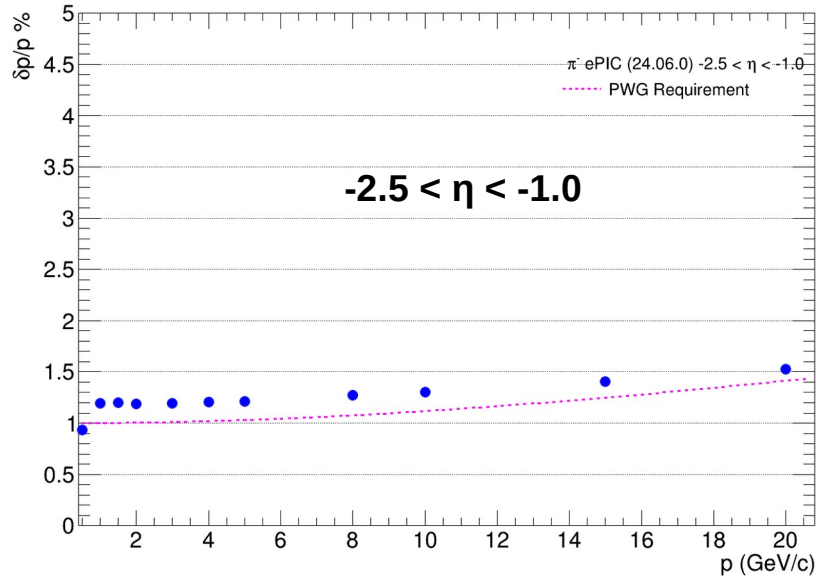

Momentum Resolutions (Truth/Real Seed)

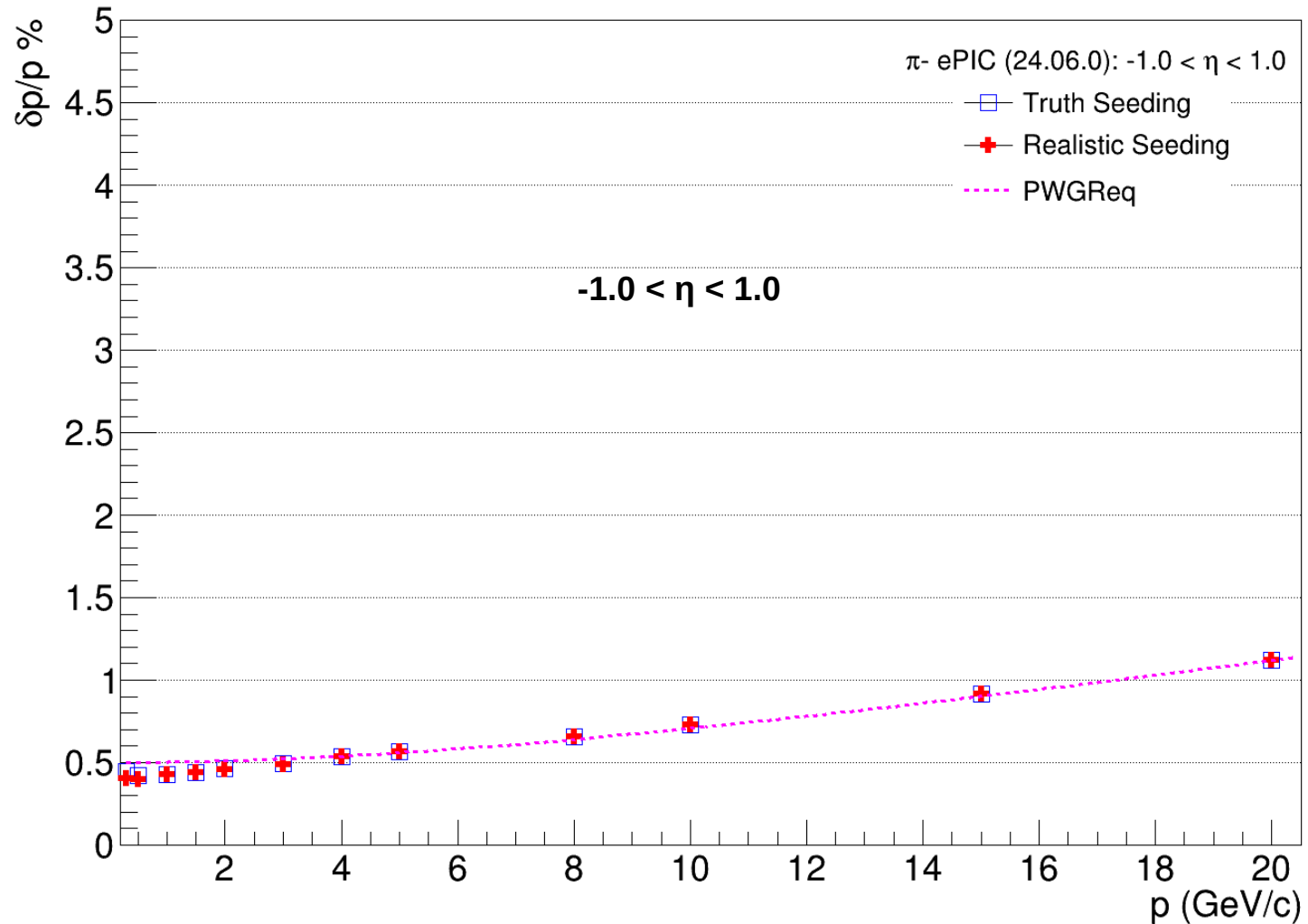

Momentum Resolutions (Truth/Real Seed)

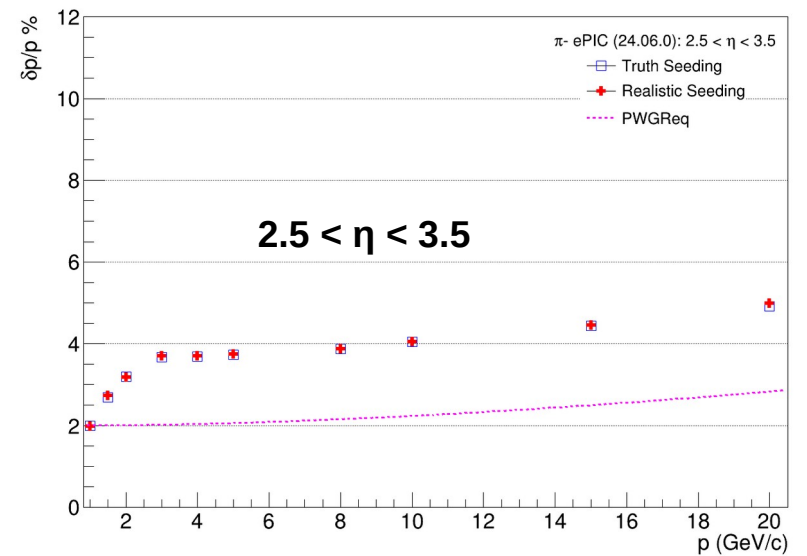
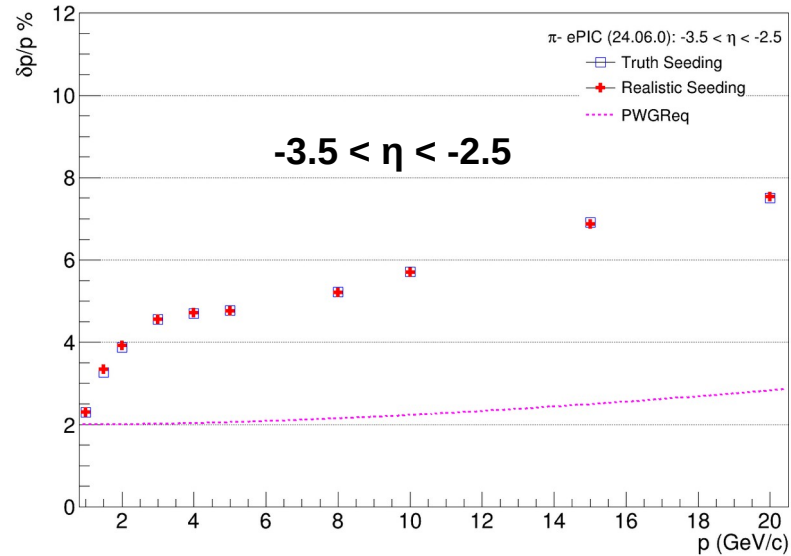
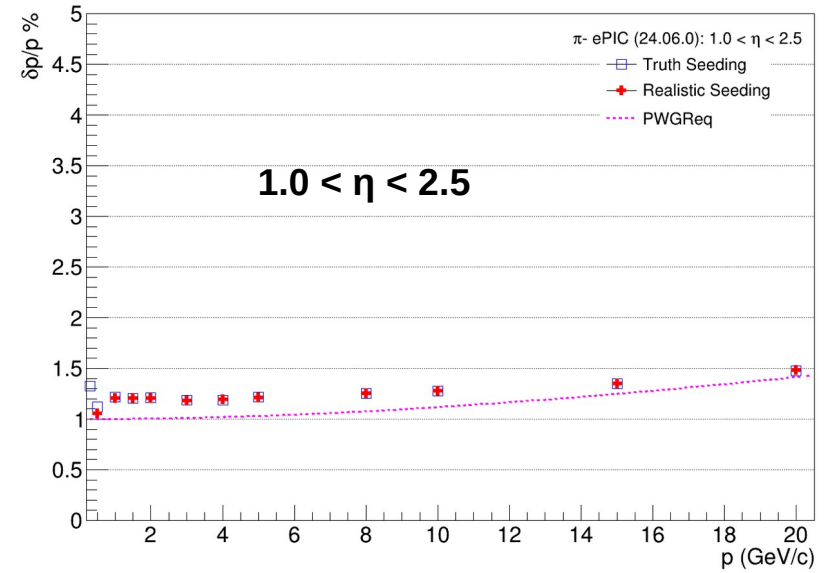
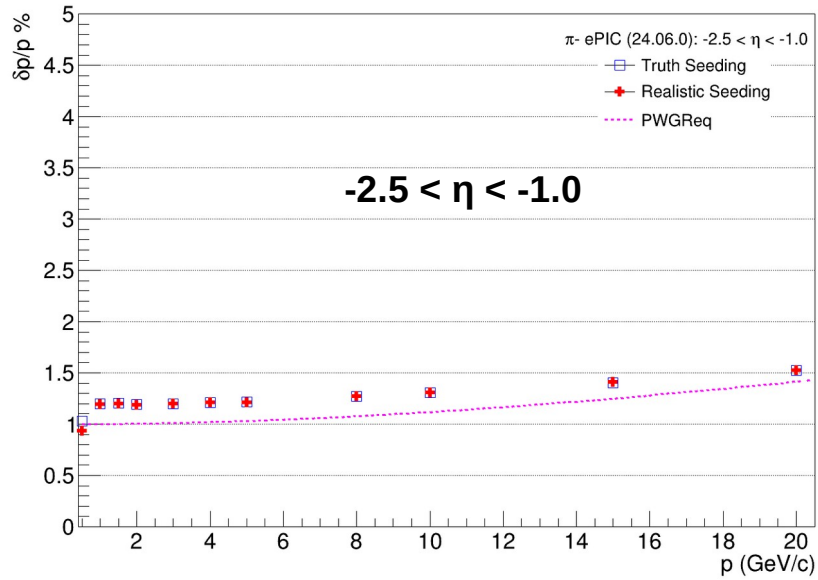

DCA_T Resolutions

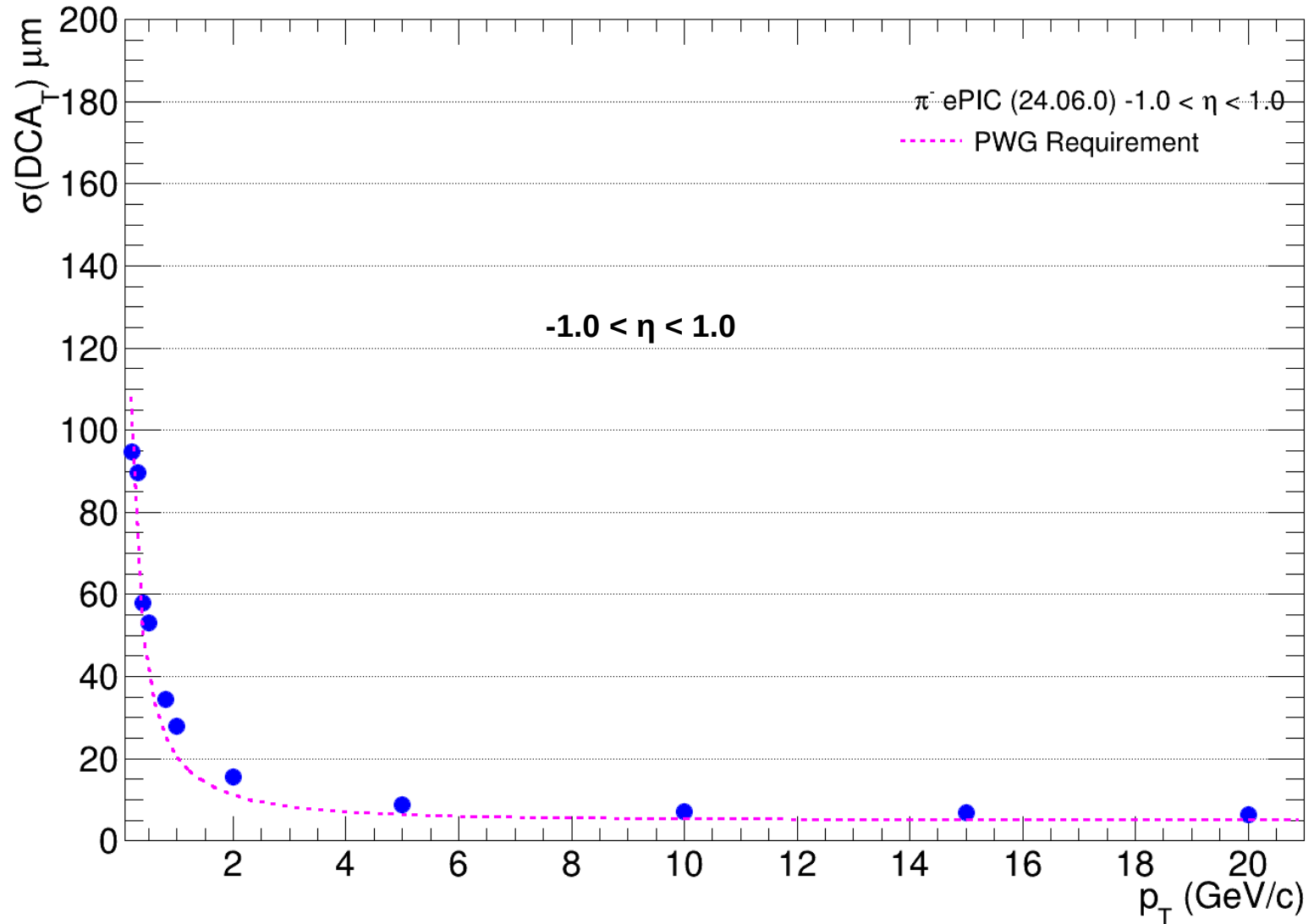

DCA_T Resolutions

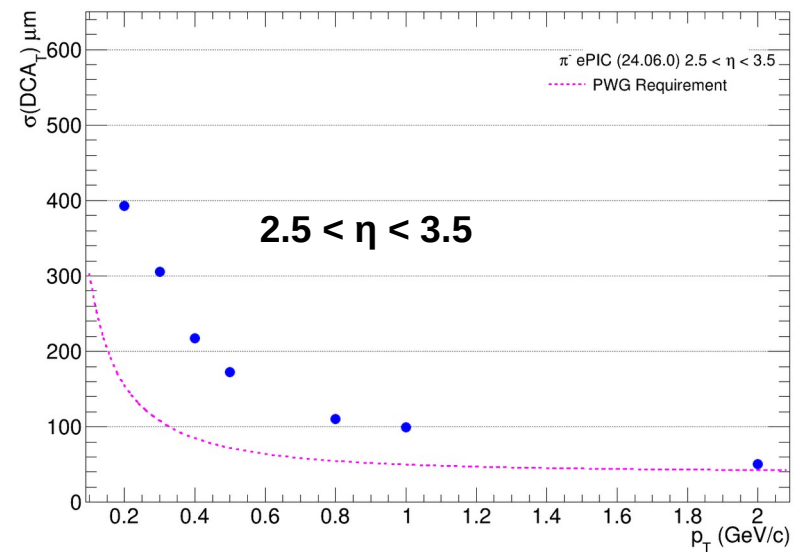
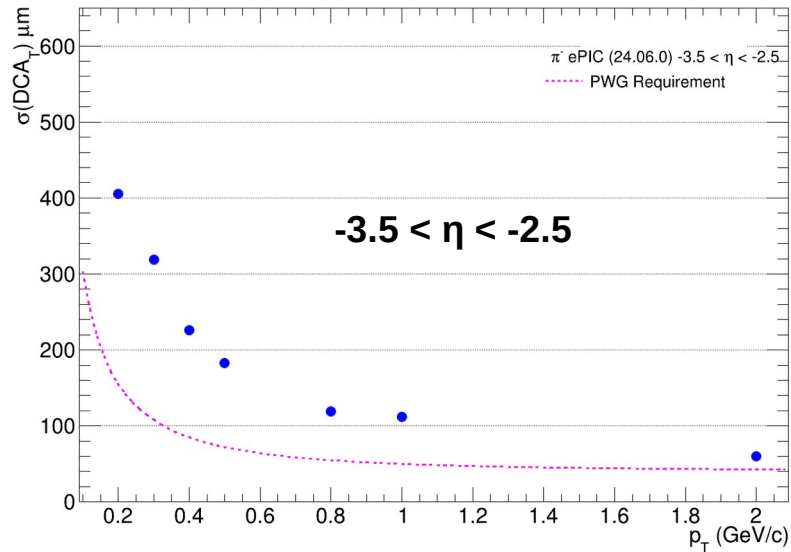
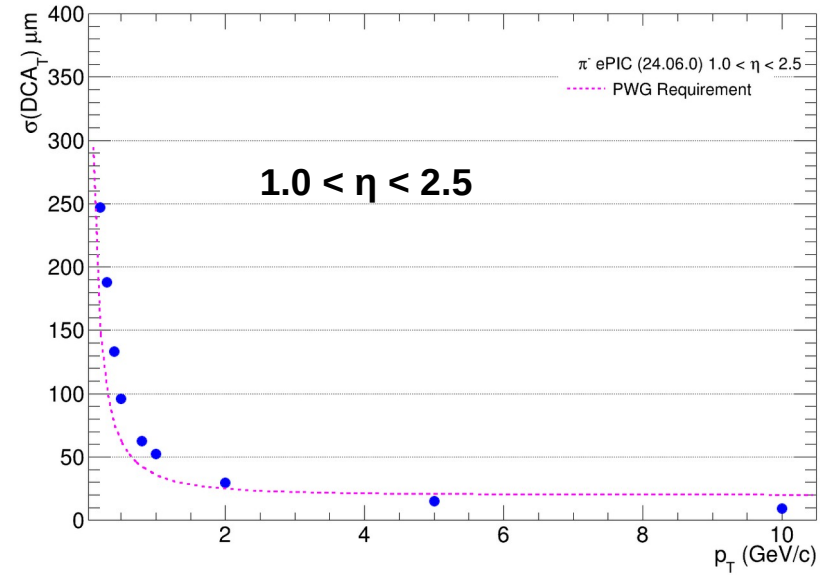
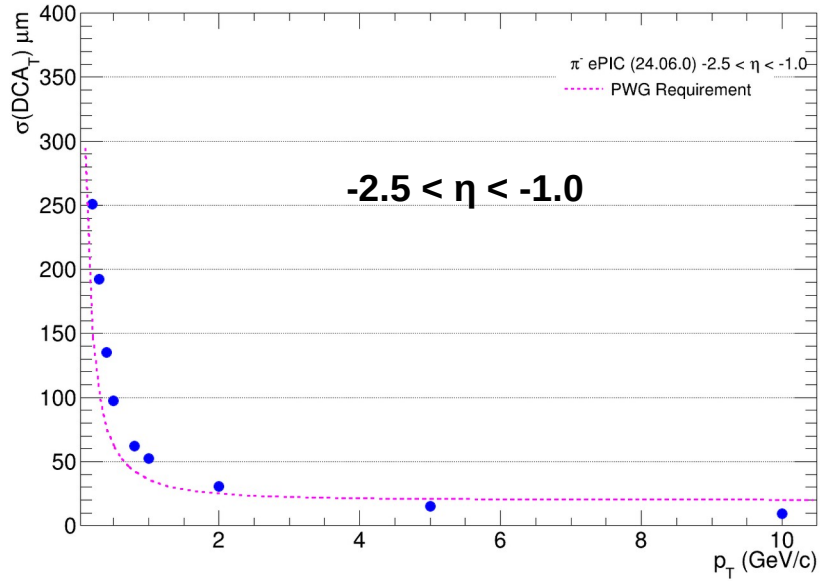

DCA_z Resolutions

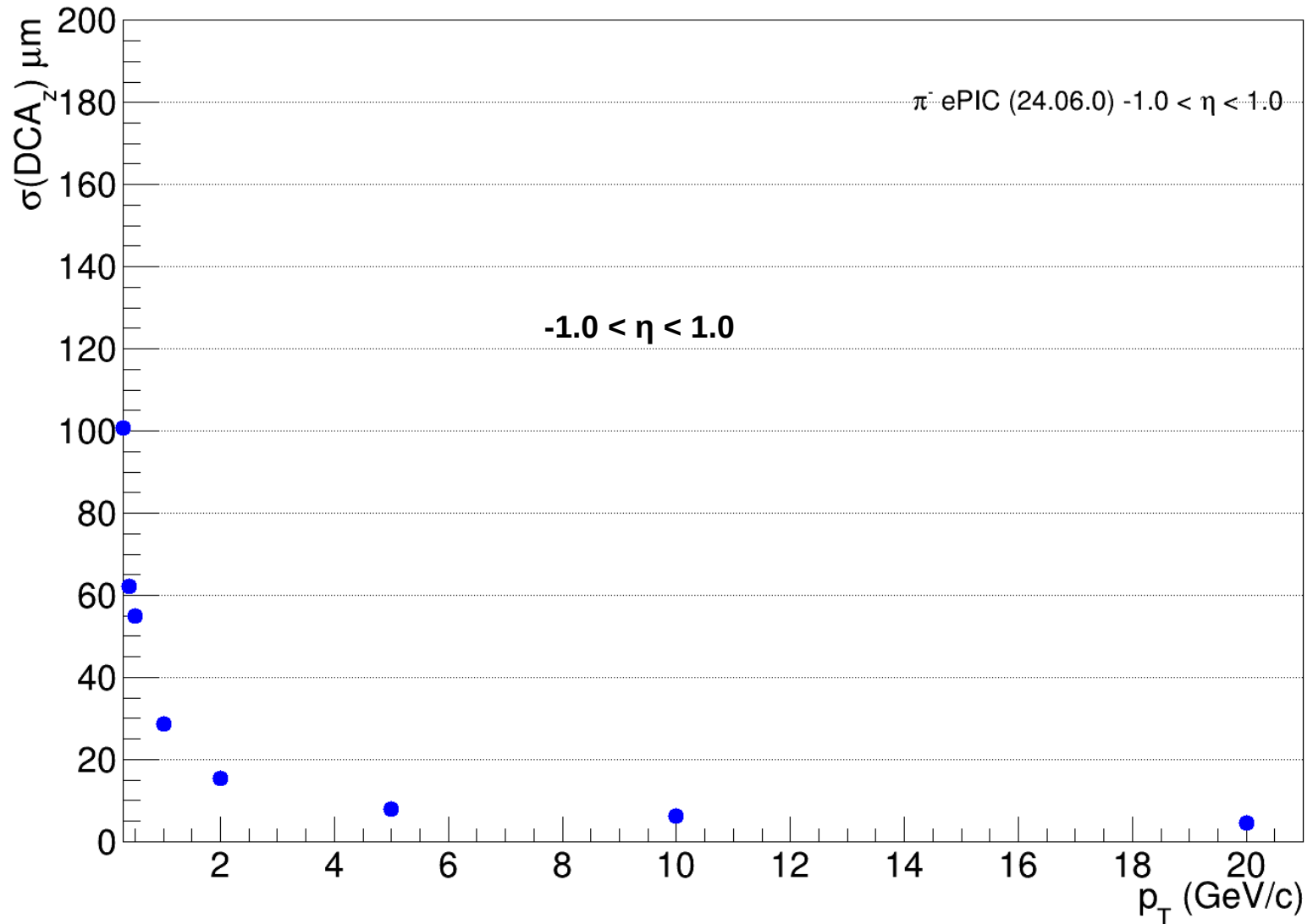

DCA_z Resolutions

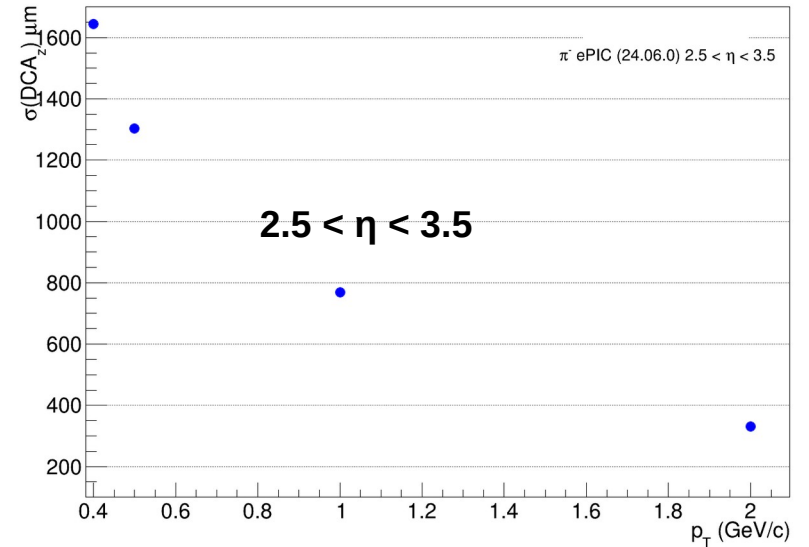
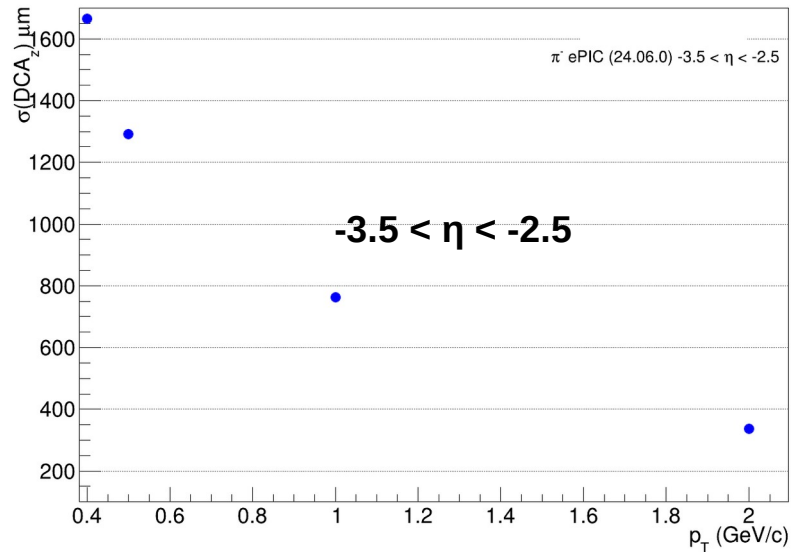
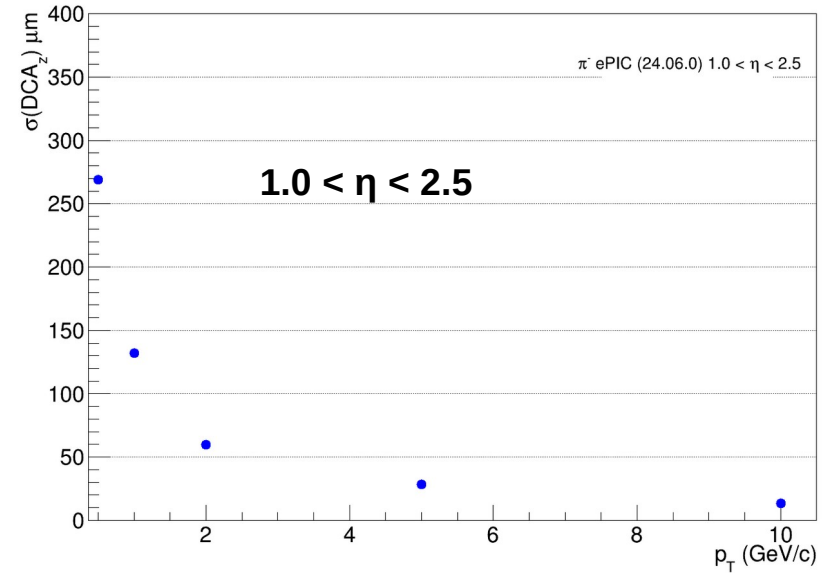
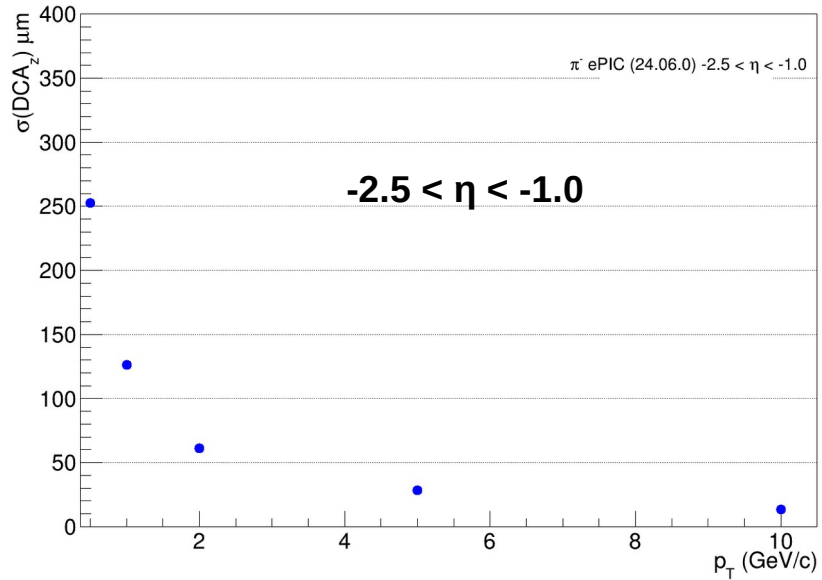

Summary

- Extracted the tracking performances with the latest geometry ePIC (24.06.0)
- The performances are improved after adding the correct material map
- Code for the validation of tracking performances also submitted to the benchmarks

Thank You !!

Different version of ePIC: Matthew Posik

https://indico.bnl.gov/event/23630/contributions/92294/attachments/54845/93843/05-30-2024-TrackingWG_CraterLakeComparisons.pdf