

# RHIC and the Electron-Ion Collider: Our Quest to Understand the Structure of Visible Matter in our Universe

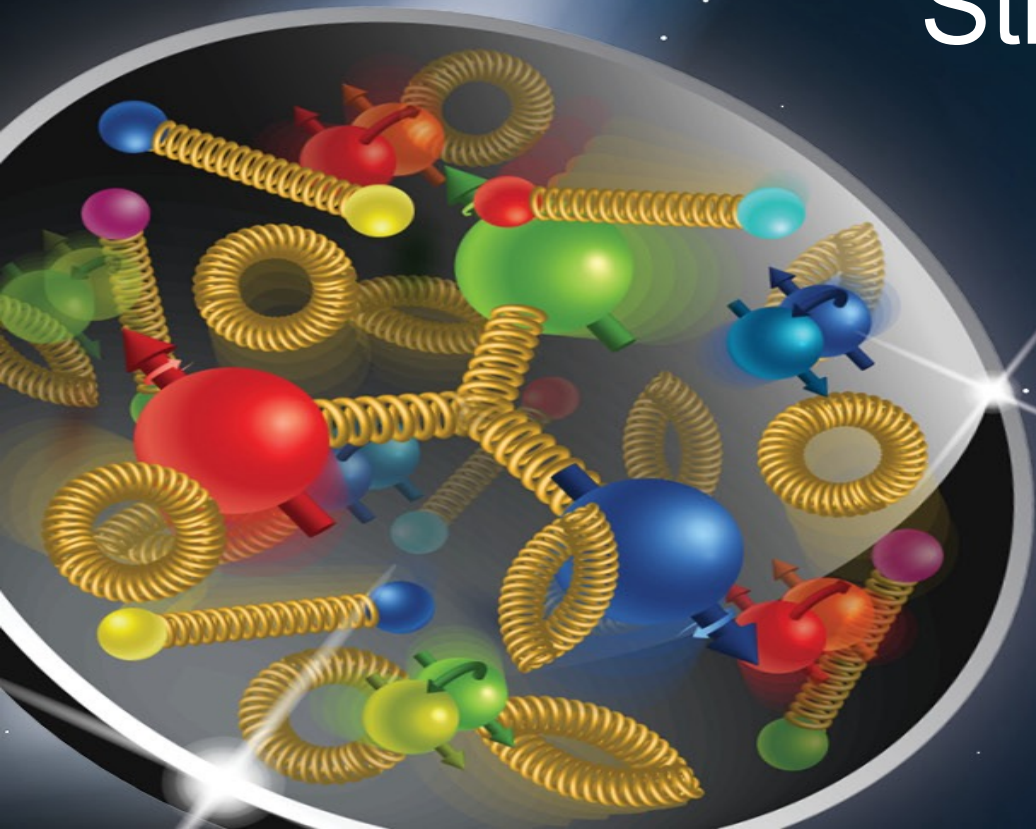

Alex Jentsch, *Brookhaven National Lab*  
[ajentsch@bnl.gov](mailto:ajentsch@bnl.gov)

*NuSTEAM/NuPUMAS @ BNL*  
*July 10<sup>th</sup>, 2024*

Electron Ion Collider

# Visible Matter

- All of the visible matter in the universe is comprised of atoms, which contain nuclei.

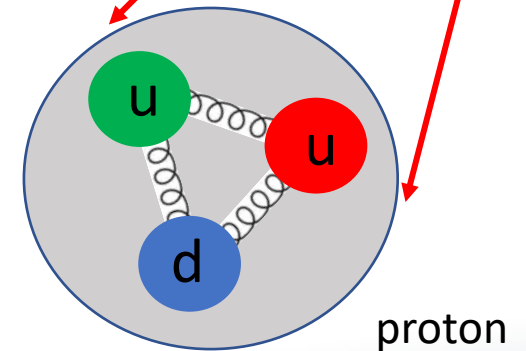
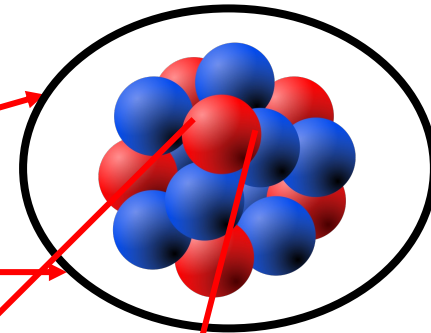
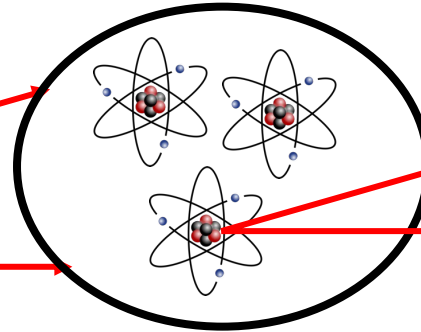
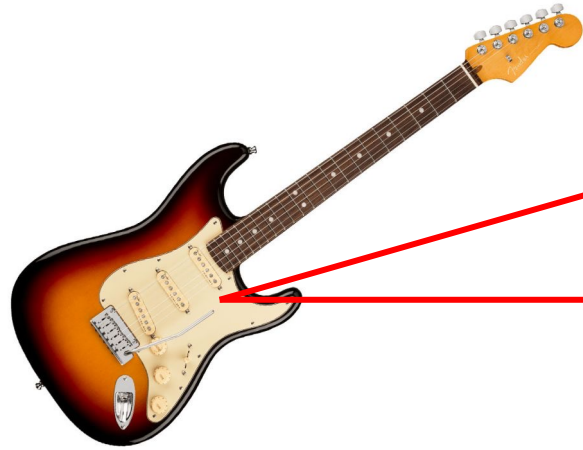

- Nuclei are held together by the strong nuclear force, which governs interactions between the “quarks” and “gluons” found inside the proton.
- Quarks and gluons collectively called “**partons**”.



# Visible Matter

- Some fundamental questions we can ask:
  - What are the properties of the proton?
    - **Spin, mass, charge.**
  - How do these properties manifest?

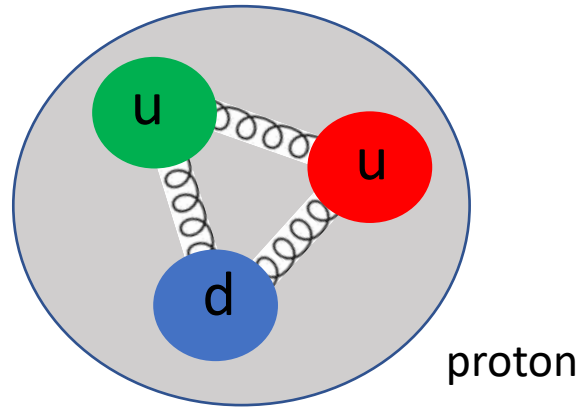

- Quantum Chromodynamics (QCD) describes the interactions between the quarks and gluons (the strong force), and introduces the concept of “color”, the strong force charge.

## Standard Model of Elementary Particles

	three generations of matter (fermions)			interactions / force carriers (bosons)	
	I	II	III		
mass	$\approx 2.2 \text{ MeV}/c^2$	$\approx 1.28 \text{ GeV}/c^2$	$\approx 173.1 \text{ GeV}/c^2$	0	$\approx 125.09 \text{ GeV}/c^2$
charge	$\frac{2}{3}$	$\frac{2}{3}$	$\frac{2}{3}$	0	0
spin	$\frac{1}{2}$	$\frac{1}{2}$	$\frac{1}{2}$	1	0
	<b>u</b> up	<b>c</b> charm	<b>t</b> top	<b>g</b> gluon	<b>H</b> higgs
	<b>d</b> down	<b>s</b> strange	<b>b</b> bottom	<b><math>\gamma</math></b> photon	
	<b>e</b> electron	<b><math>\mu</math></b> muon	<b><math>\tau</math></b> tau	<b>Z</b> Z boson	
	<b><math>\nu_e</math></b> electron neutrino	<b><math>\nu_\mu</math></b> muon neutrino	<b><math>\nu_\tau</math></b> tau neutrino	<b>W</b> W boson	

**QUARKS** (left side of the table)

**LEPTONS** (left side of the table)

**GAUGE BOSONS VECTOR BOSONS** (bottom left side of the table)

**SCALAR BOSONS** (bottom right side of the table)

# The proton gets even more complicated

- As you ramp up the energy, the proton becomes awash with more partons (quarks and gluons)!

Three “valence” quarks  
inside proton.

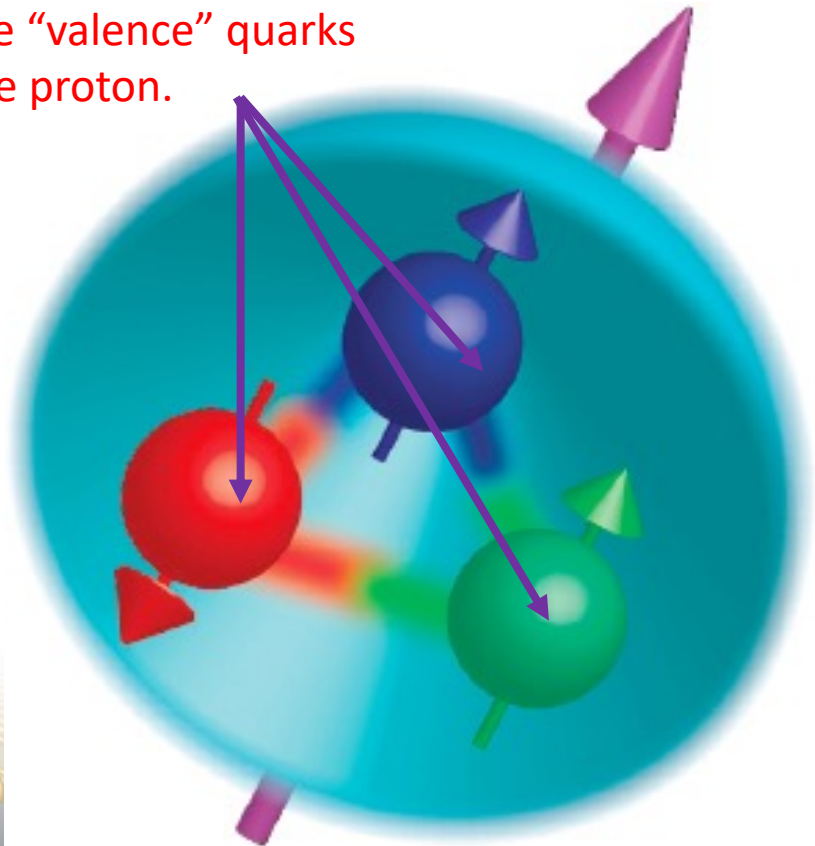

# The Proton Spin Puzzle

Spin structure – the three “valence” quarks do not account for the total spin of the proton!

$$\text{Proton spin: } \frac{1}{2} = \frac{1}{2} \sum_q \Delta q + \Delta G + L_{g,q}$$

quarks                  gluons

Orbital  
angular  
momentum

Only 20-30% comes from the quarks!

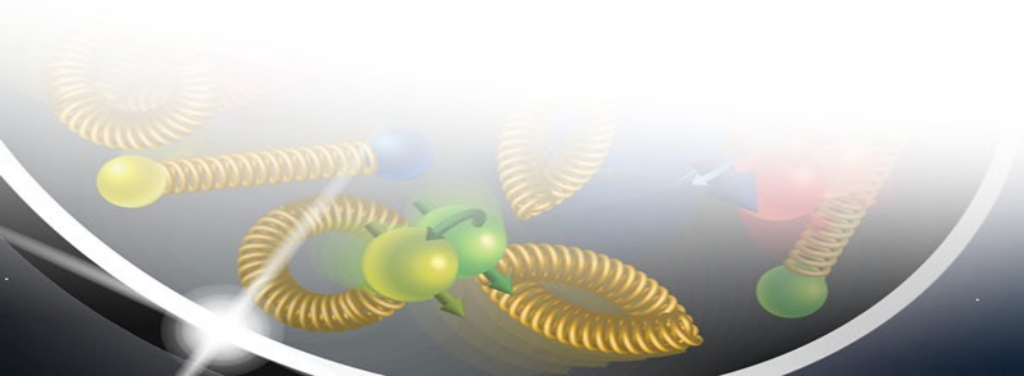
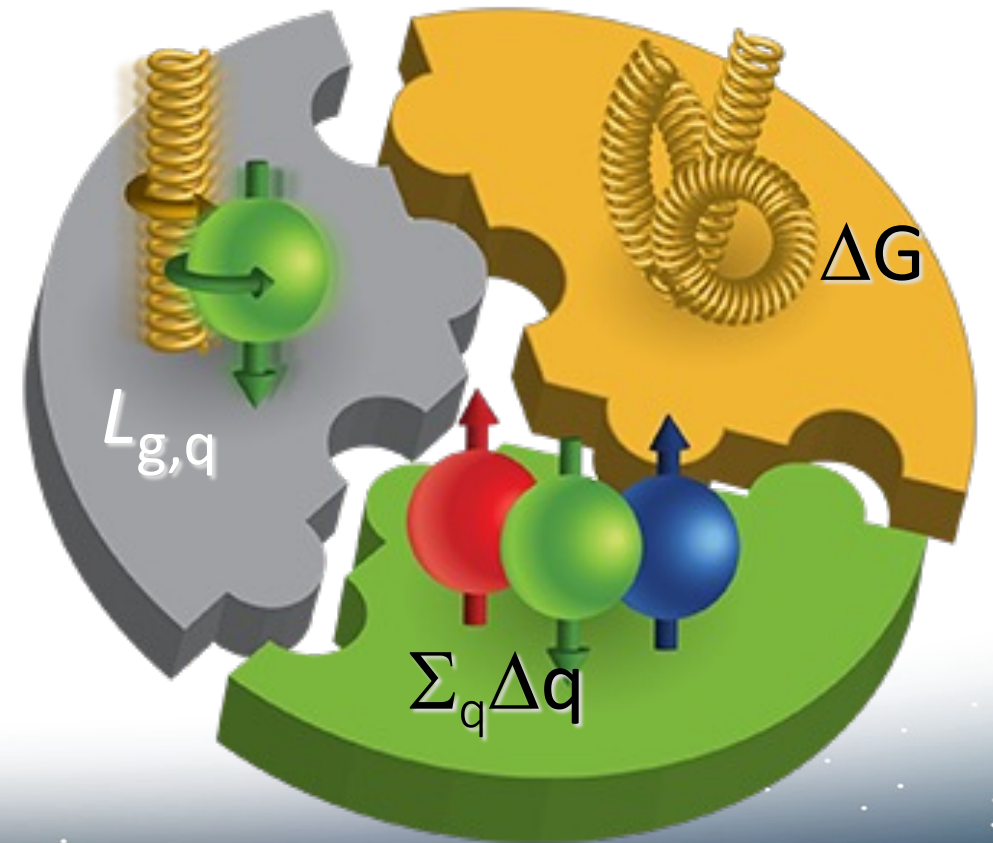

# The Proton Mass

- The proton mass composition is also rather complicated to pin-down!

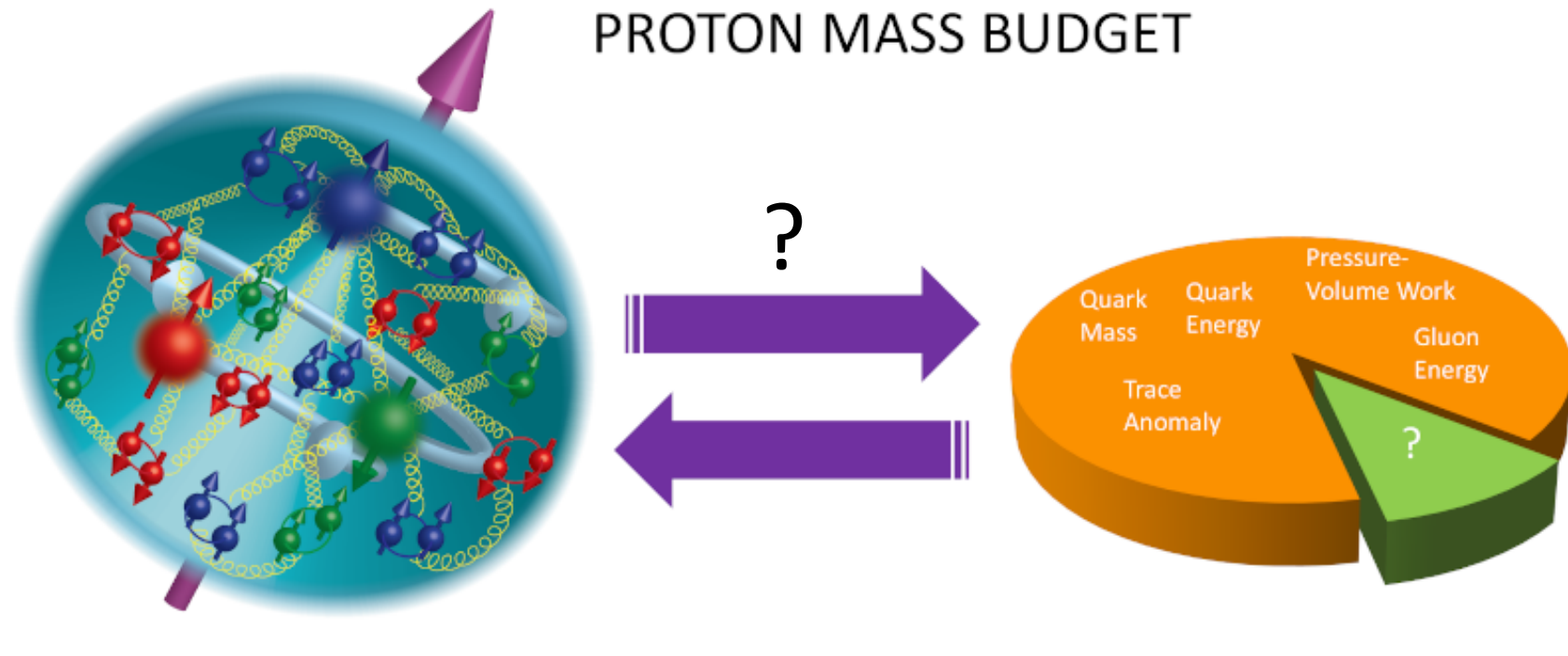

- Mass does not arise as simple sum of quark masses!
- ~ 99% of the mass is driven by quark and gluon dynamics!

# Some QCD Peculiarities

Another peculiar thing about QCD: confinement.

3-quarks: baryon  
Quark + anti-quark: mesons  
Collectively: hadrons

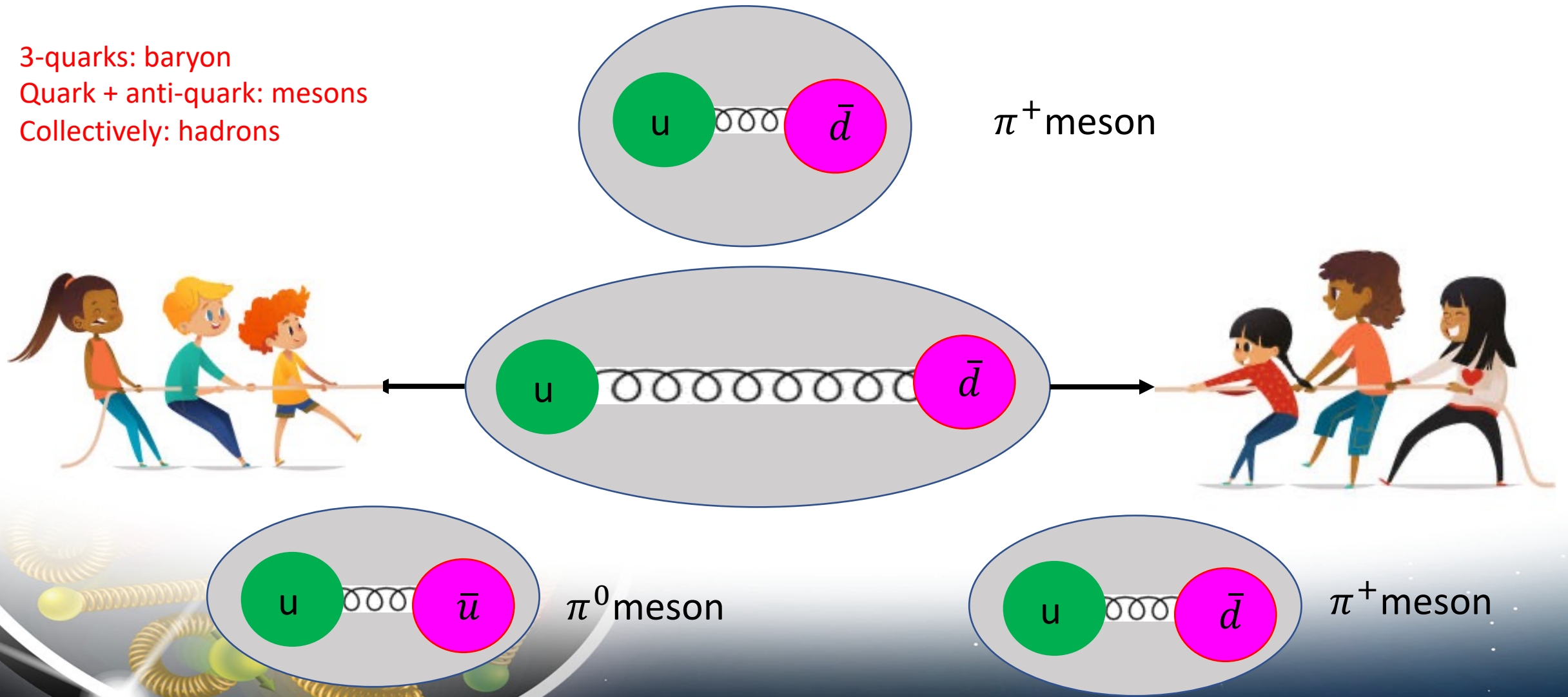

# Some QCD Peculiarities

An additional wrinkle in QCD → **gluons can interact with themselves.**

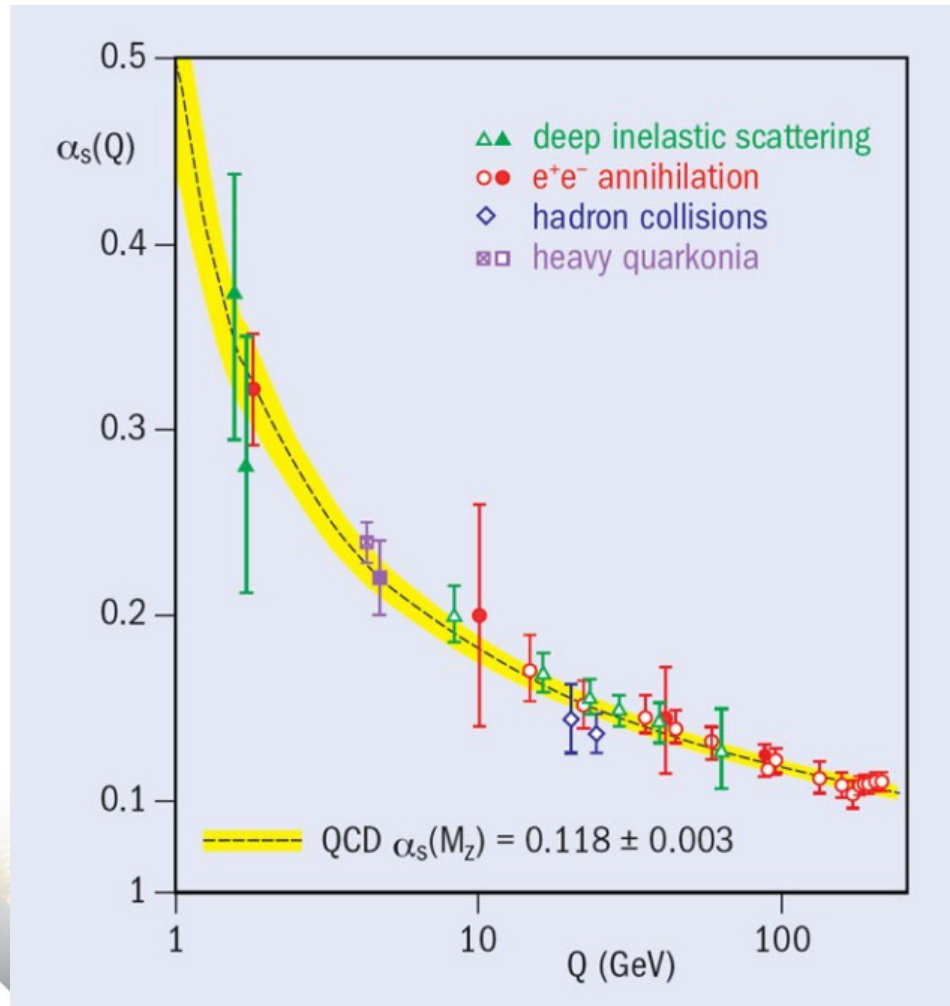

Short distance (high-energy) = small coupling (weaker interaction).

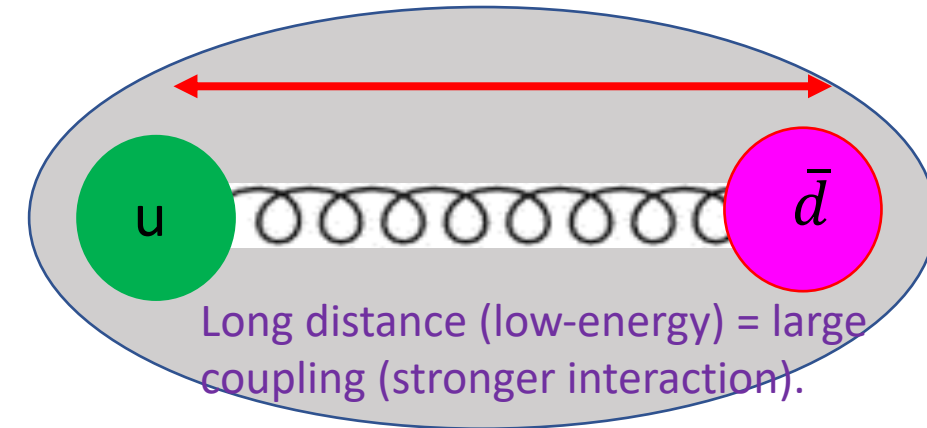
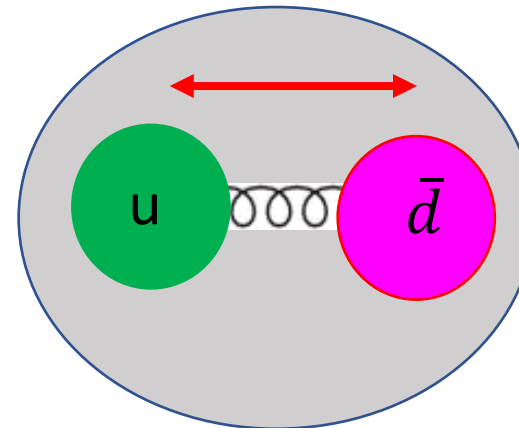

- Opposite of the EM force and gravity, which decrease as a function of  $\frac{1}{(\text{distance})^2}$ .
- Consequences:
  - QCD calculations become non-perturbative (exceedingly hard) when the coupling constant is large (i.e. at low energy).

Image credit: From figure 5 in Siegfried Bethke and Peter Zerwas 2004 *Physik Journal* **3** 12 31.

**QCD requires experimental data to make progress!**



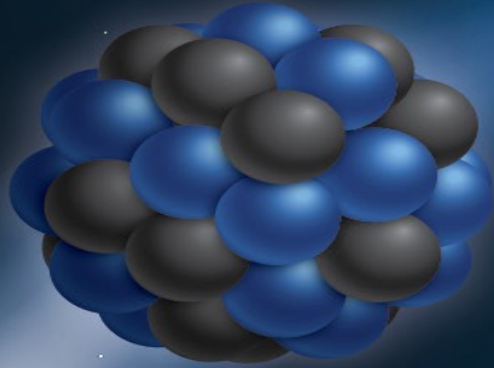

Okay, so the structure of matter  
and QCD seem complicated...how  
can we study them?

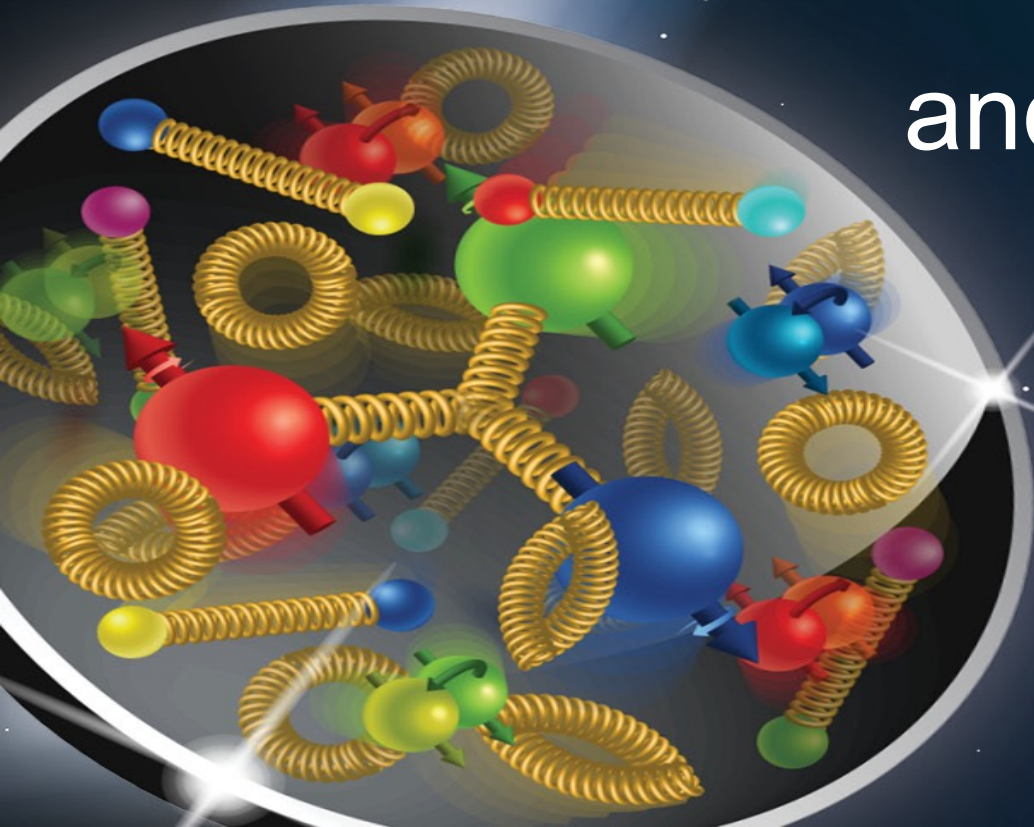

# Different kinds of interactions (just a few)

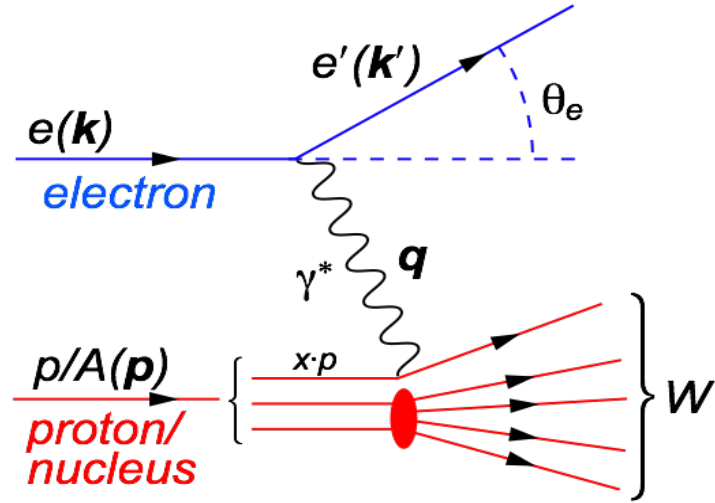

## Deep-Inelastic Scattering:

electron + proton (or nucleus) collisions

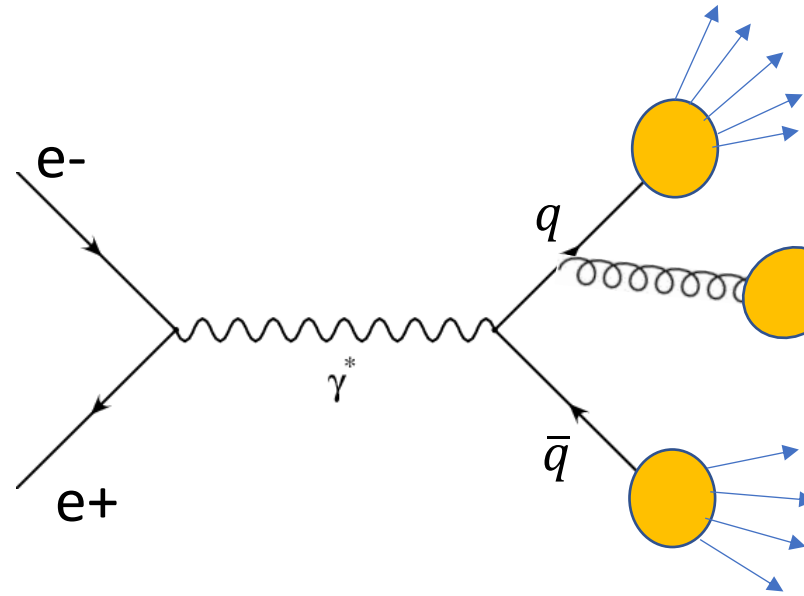

## Electron + positron annihilation:

electron + positron collisions

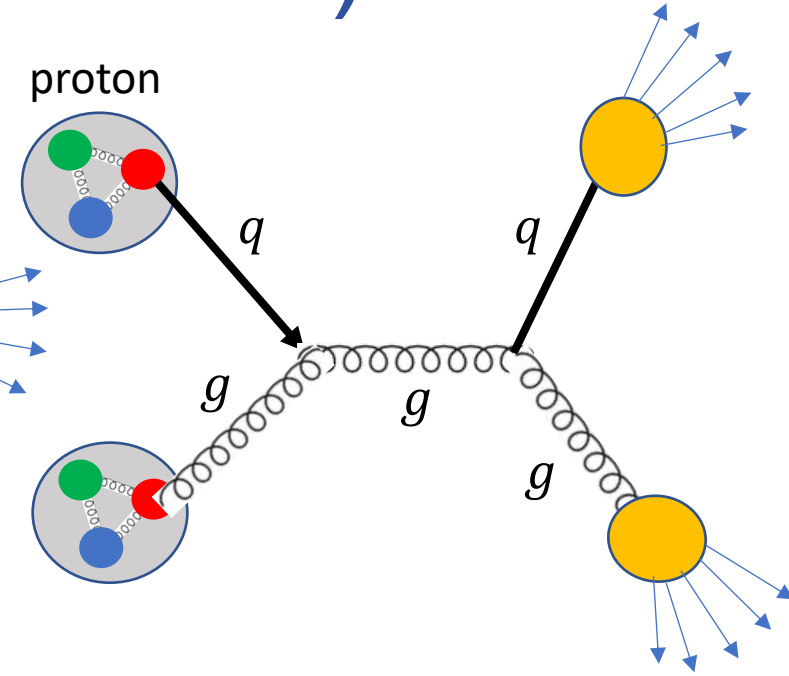

## Hadronic interactions:

Proton + proton collisions

Led to discovery of the quark! (SLAC)

Led to discovery of the gluon! (PETRA)

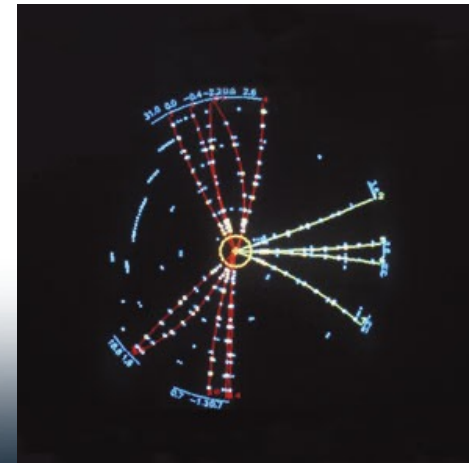

Discovery of the Higgs! (LHC)

# Building our microscope!

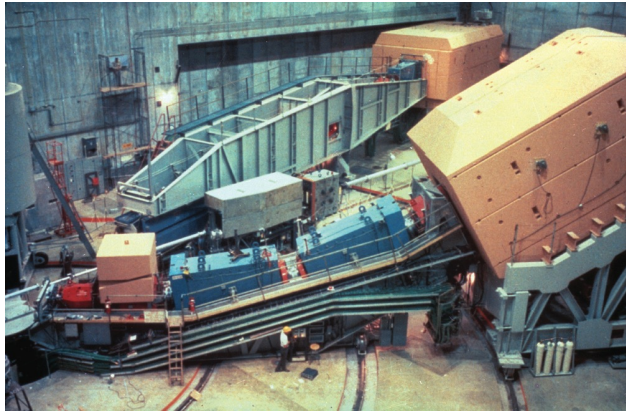

SLAC 1969:  $e + p$  (fixed)

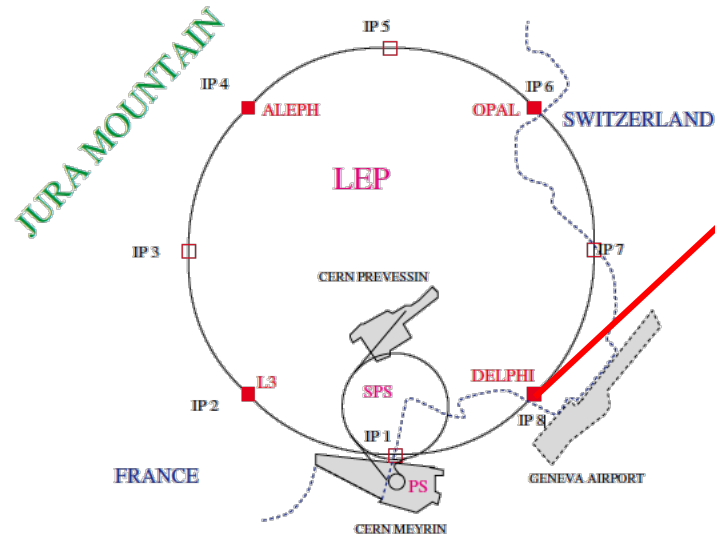

LEP @ CERN: 1989-2001:  $e+e-$

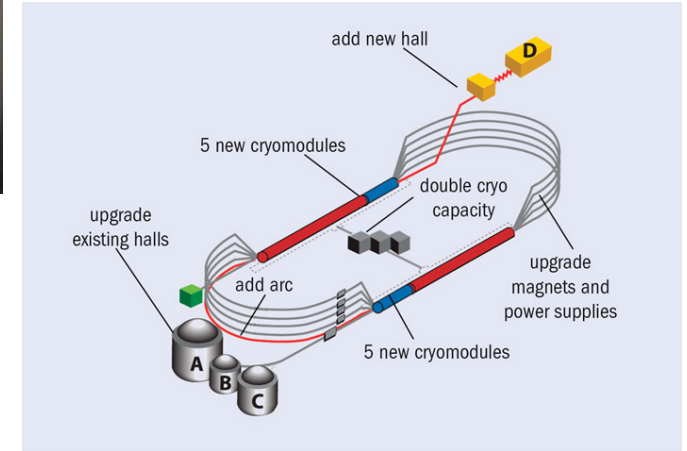

JLAB/CEBAF: 1984 – present:  $e + p$  (fixed)

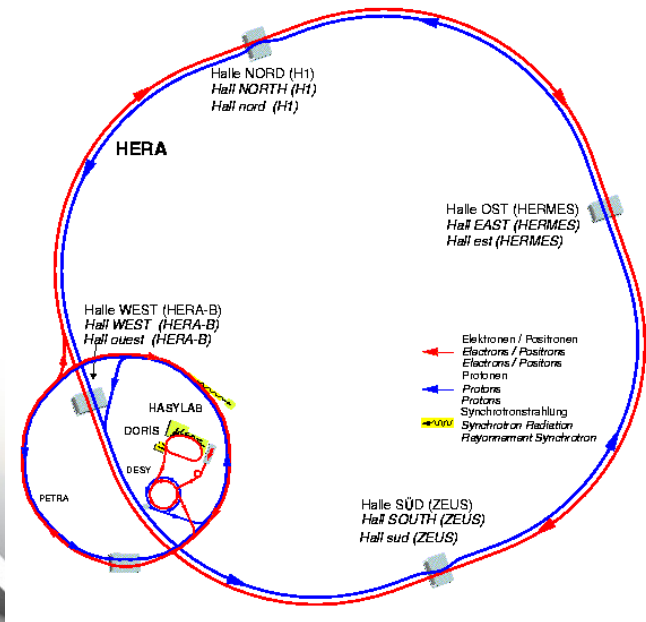

HERA: 1998-2007:  $e + p$  (collider)

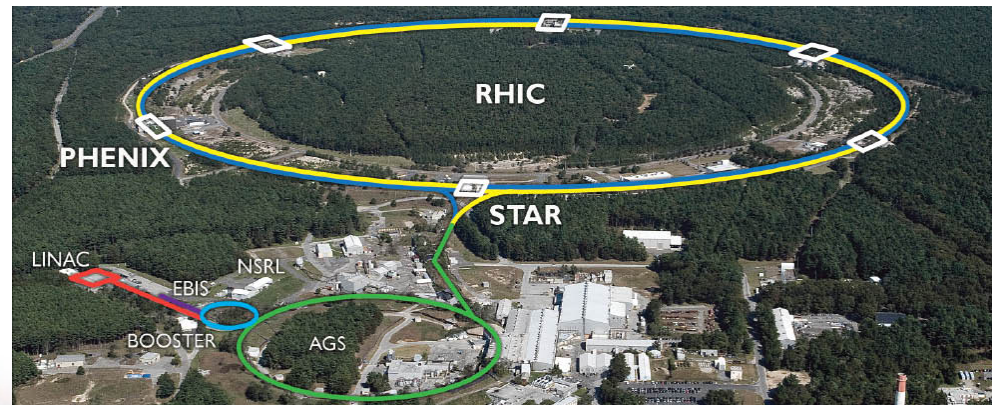

RHIC: 2000 – present:  $p+p$ ,  $p+A$ ,  $A+A$ , polarized protons

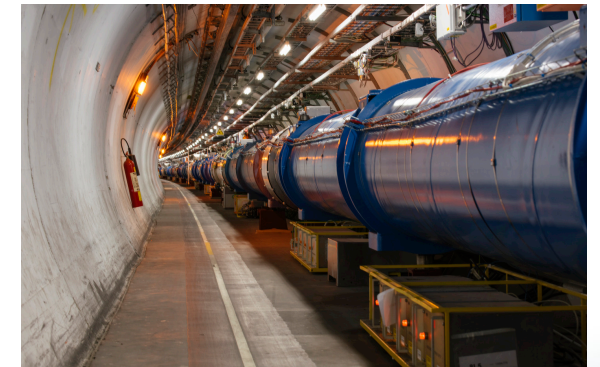

LHC: 2008 – present:  $p+p$ ,  $p+A$ ,  $A+A$

# Building our microscope!

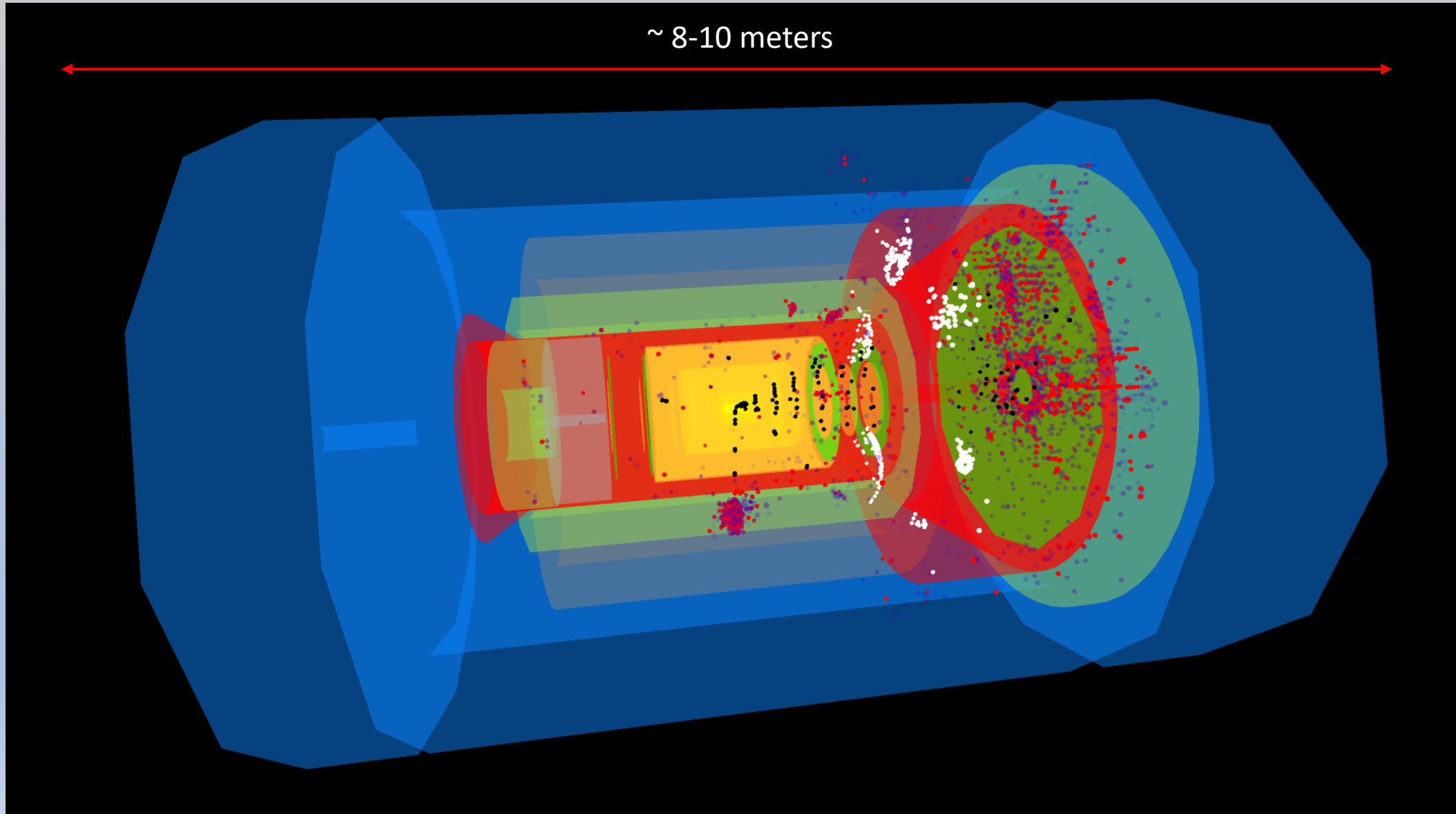

# “Illuminating” the Structure of Matter

- Use Deep-Inelastic Scattering (DIS)

- Collide electrons with protons or nuclei – the photon that is exchanged literally **illuminates** the target, allowing you to build a microscope of sorts to study the structure of matter!

electron + proton

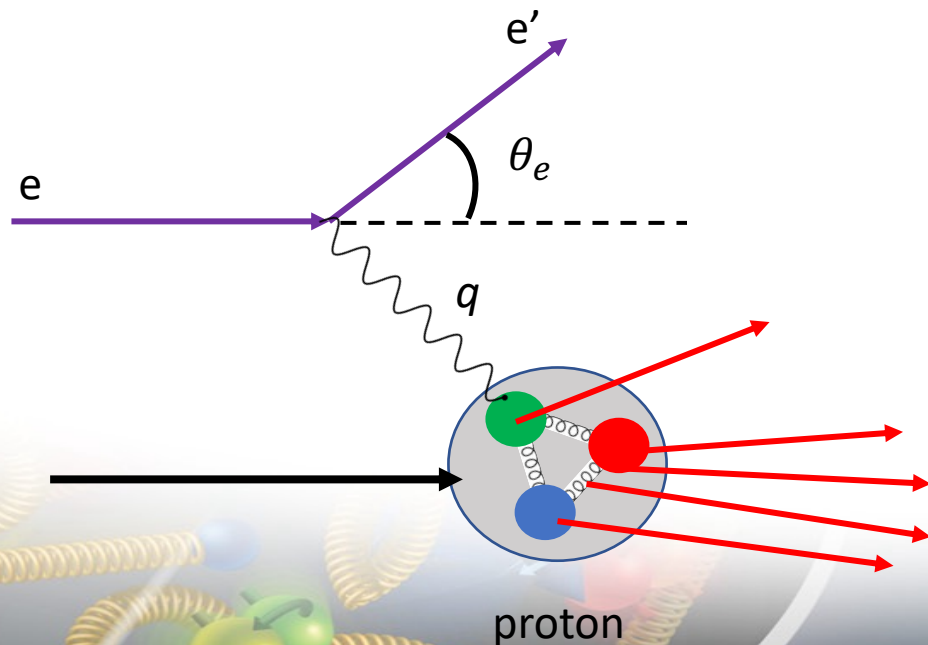

electron + nucleus

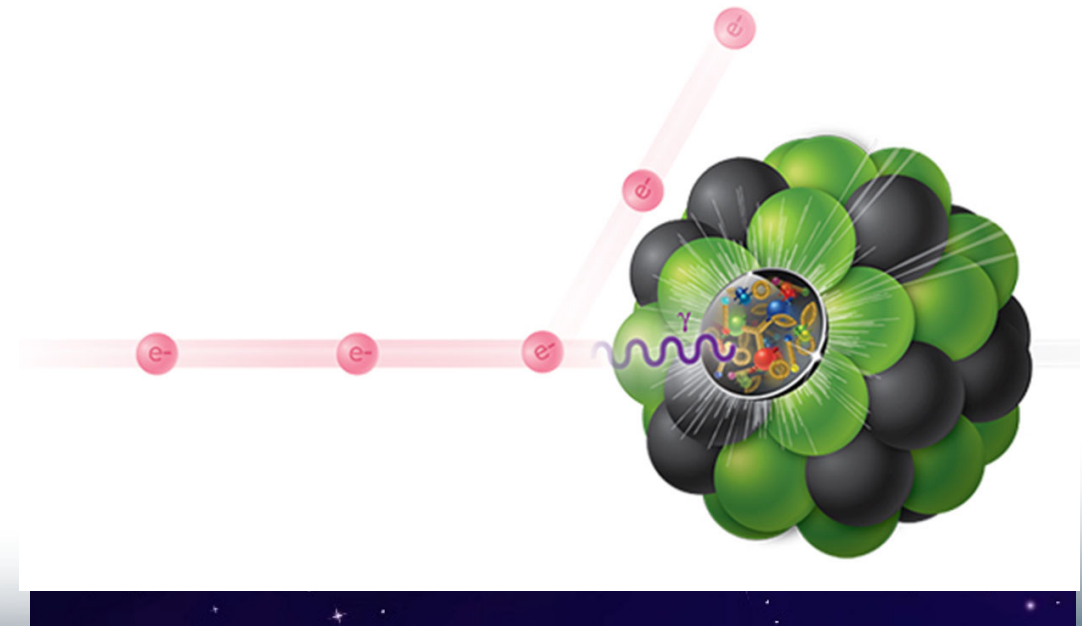

# “Illuminating” the Structure of Matter

$$Q^2 = 2E_e E'_e (1 - \cos\theta'_e) = -q^2$$

Measure of resolution power

Kinematics:

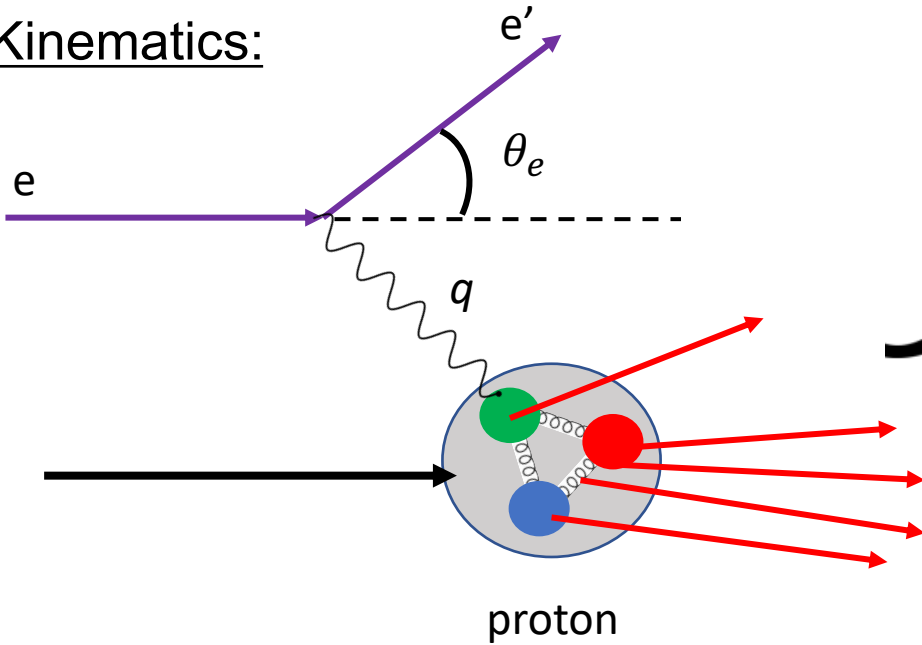

*Low  $Q^2$*  = low resolution

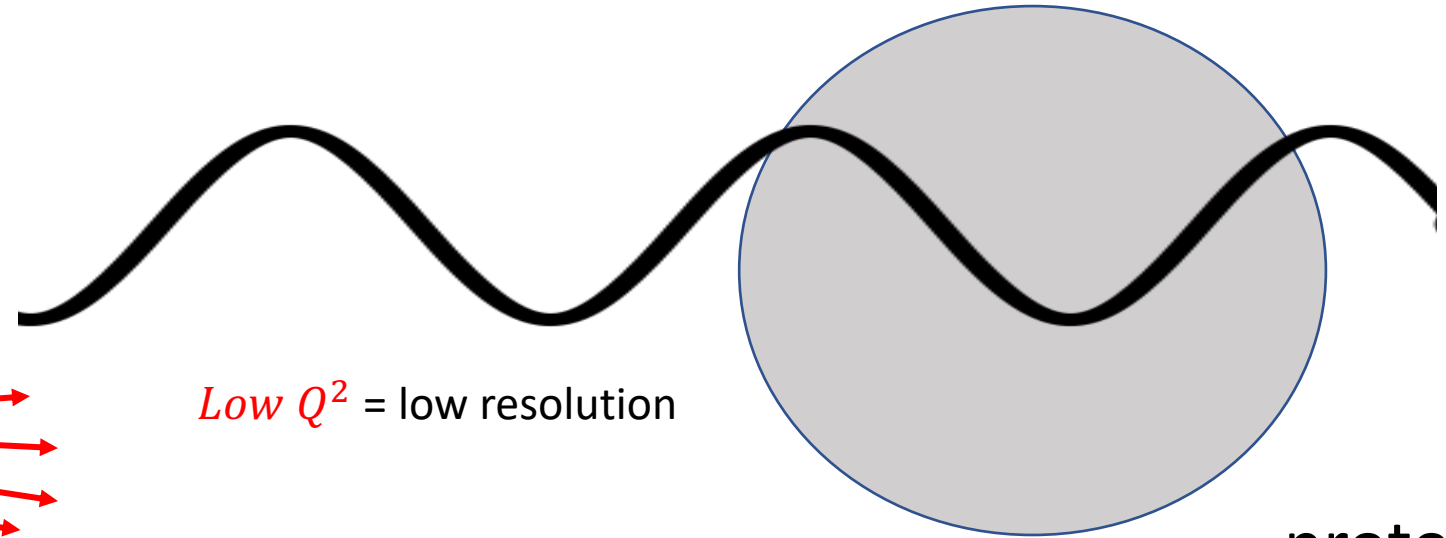

*High  $Q^2$*  = high resolution

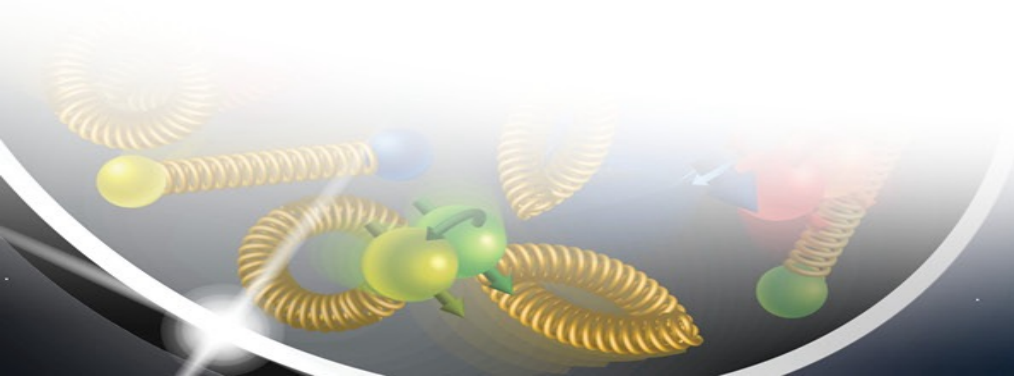
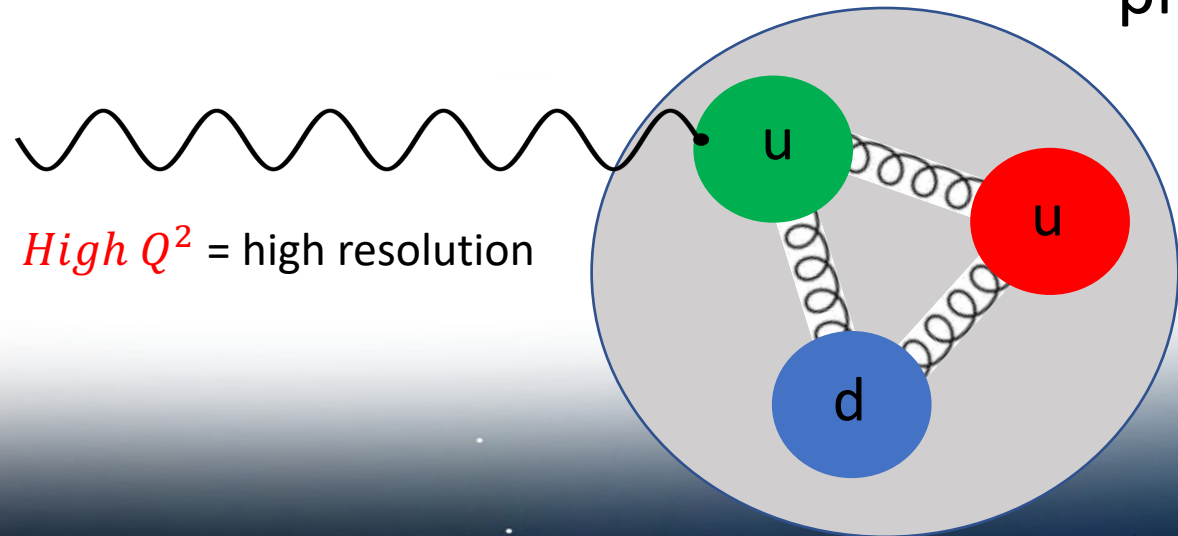

# “Illuminating” the Structure of Matter

$$Q^2 = 2E_e E'_e (1 - \cos\theta'_e) = -q^2$$

Measure of resolution power

$$x = \frac{Q^2}{2pq}$$

Measure of momentum fraction of struck parton

“Bjorken-x”

Kinematics:

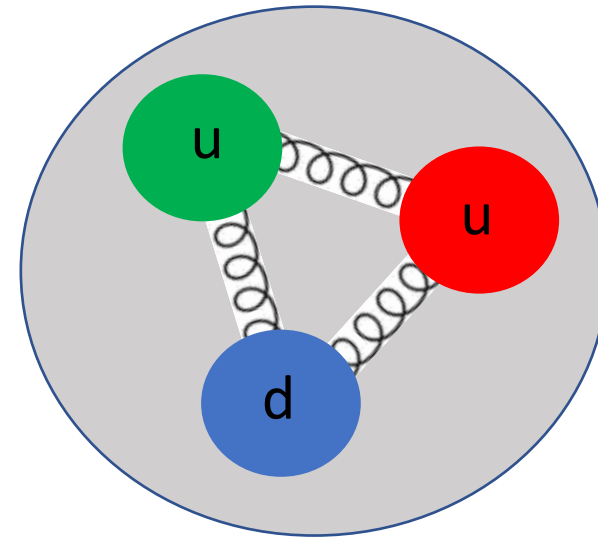
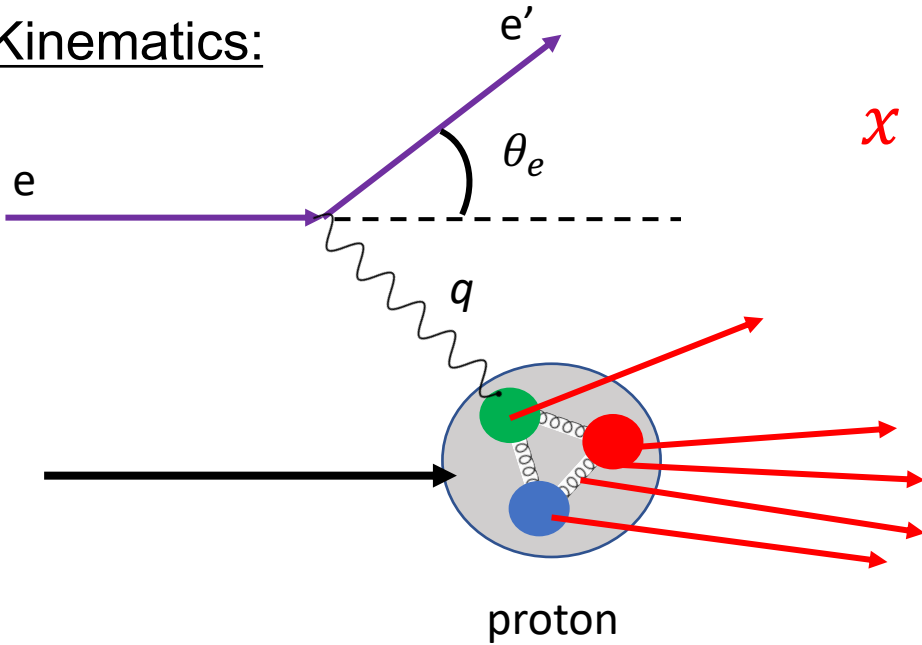

$x \sim 1/3$  for just the “valence” quarks.

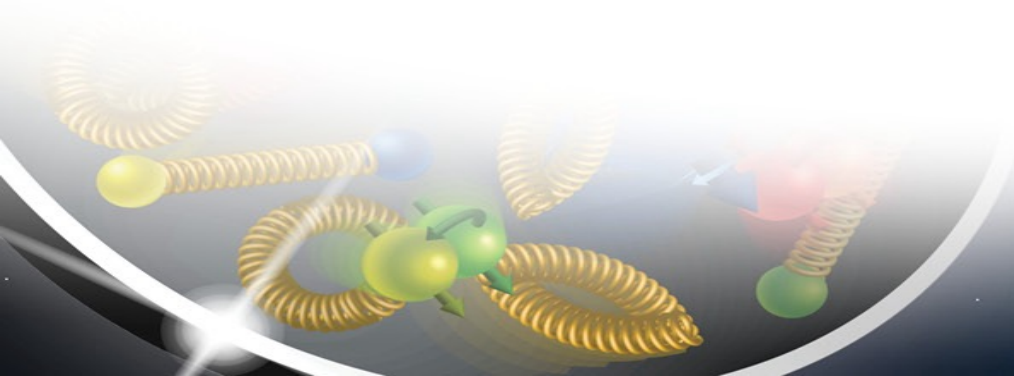

# “Illuminating” the Structure of Matter

$$Q^2 = 2E_e E'_e (1 - \cos\theta'_e) = -q^2$$

Measure of resolution power

$$x = \frac{Q^2}{2pq}$$

Measure of momentum fraction of struck parton

“Bjorken-x”

Kinematics:

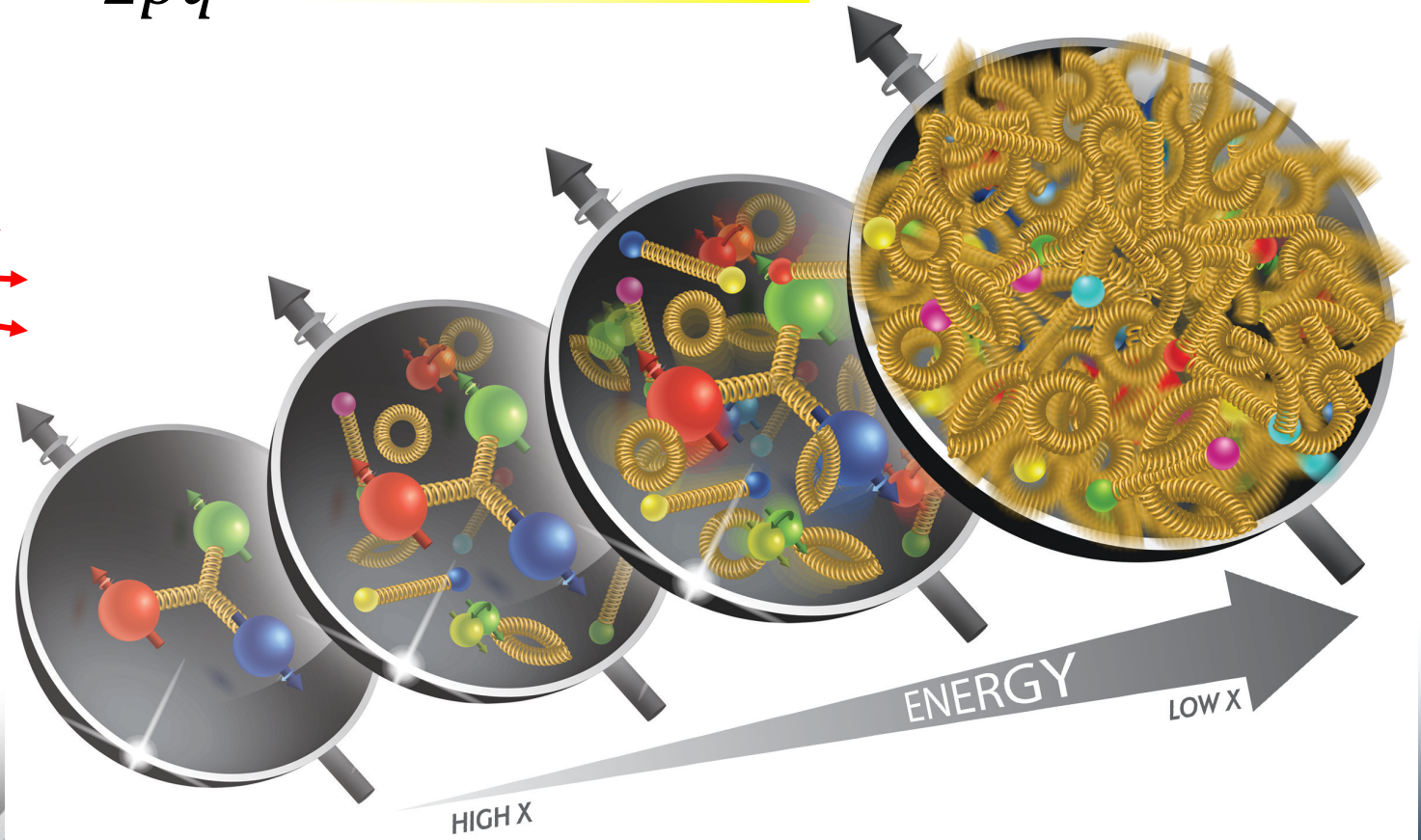
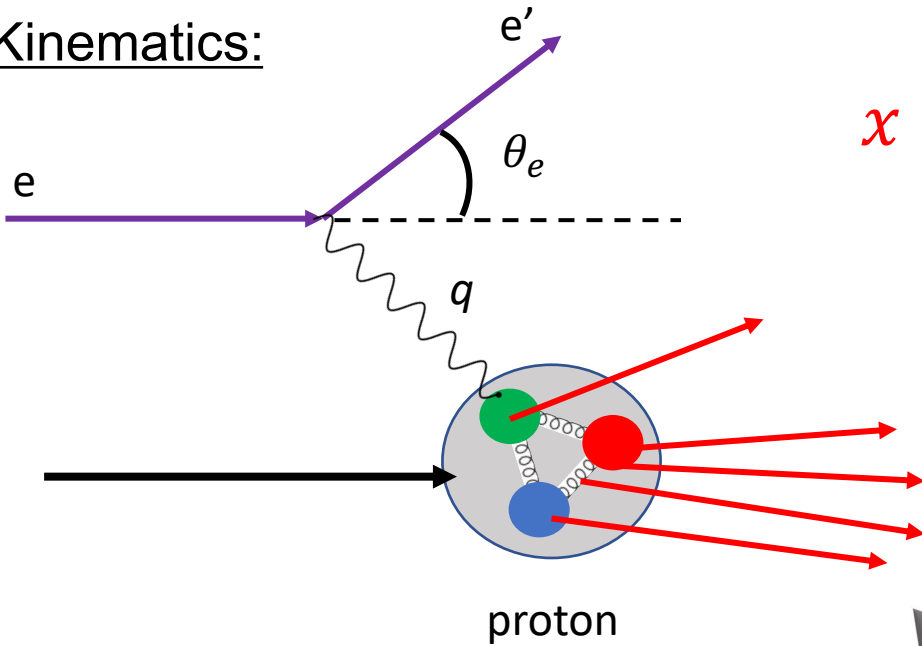



# Physics aside: Exotic QCD state at low-x

Saturation – gluon density increases drastically at low-x! At some point, does the density saturate? **New state of matter?**

## Parton Distribution Function (PDF)

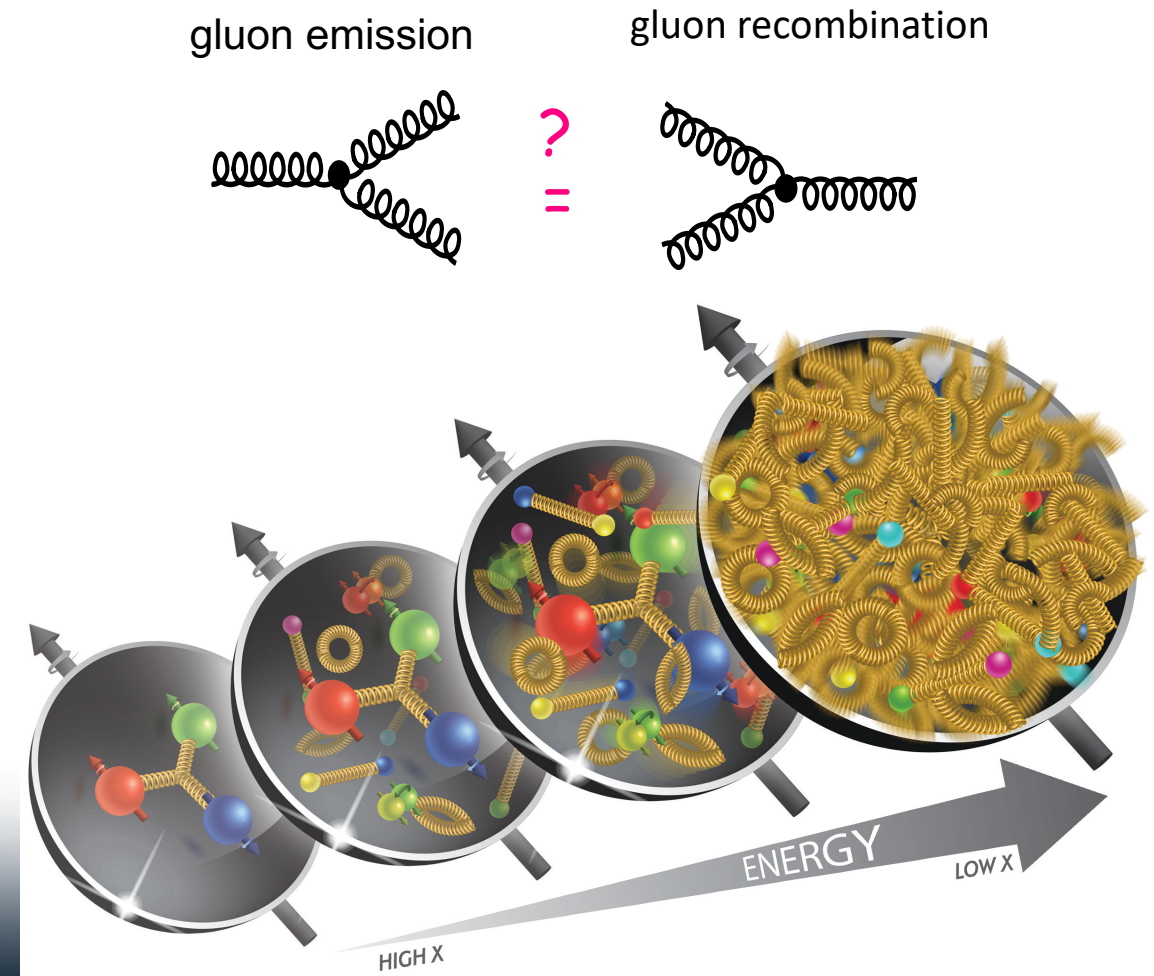
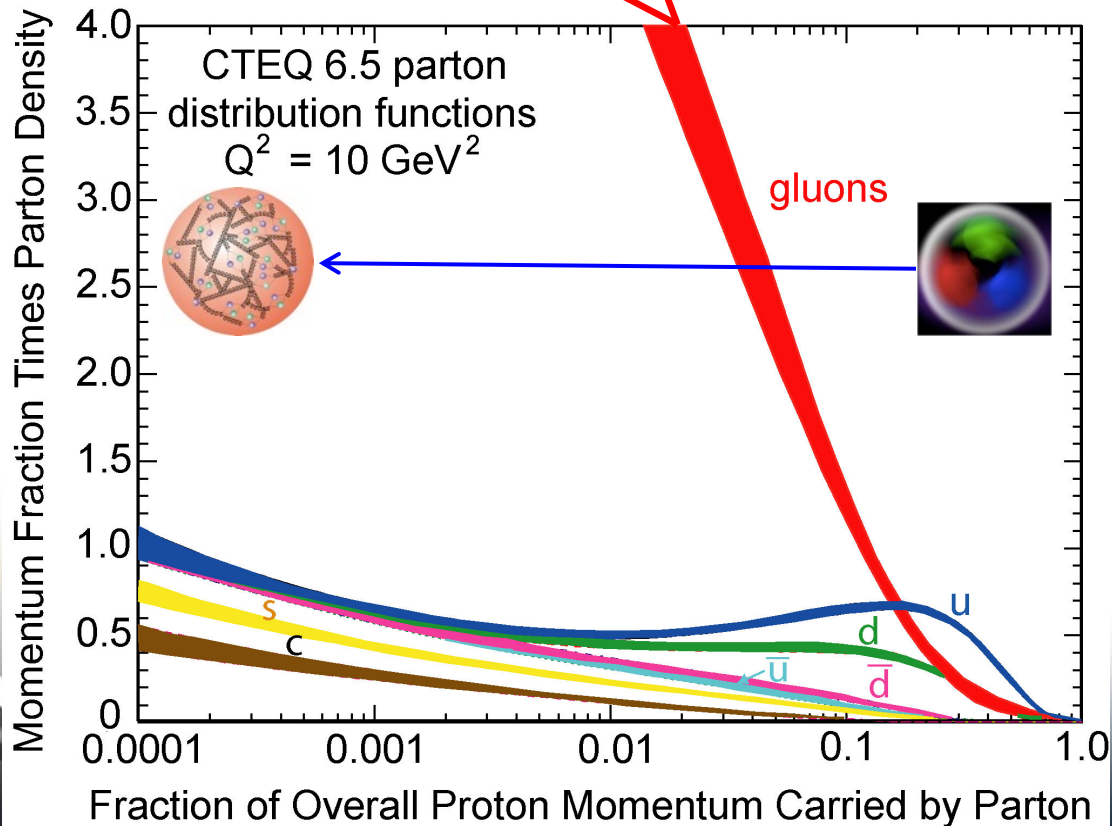

# What is needed experimentally?

EIC Yellow Report, Fig. 2.1

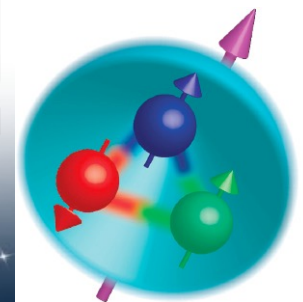
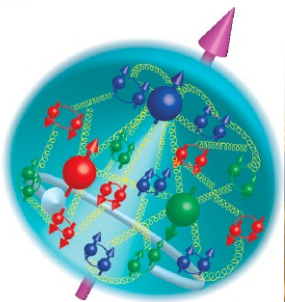
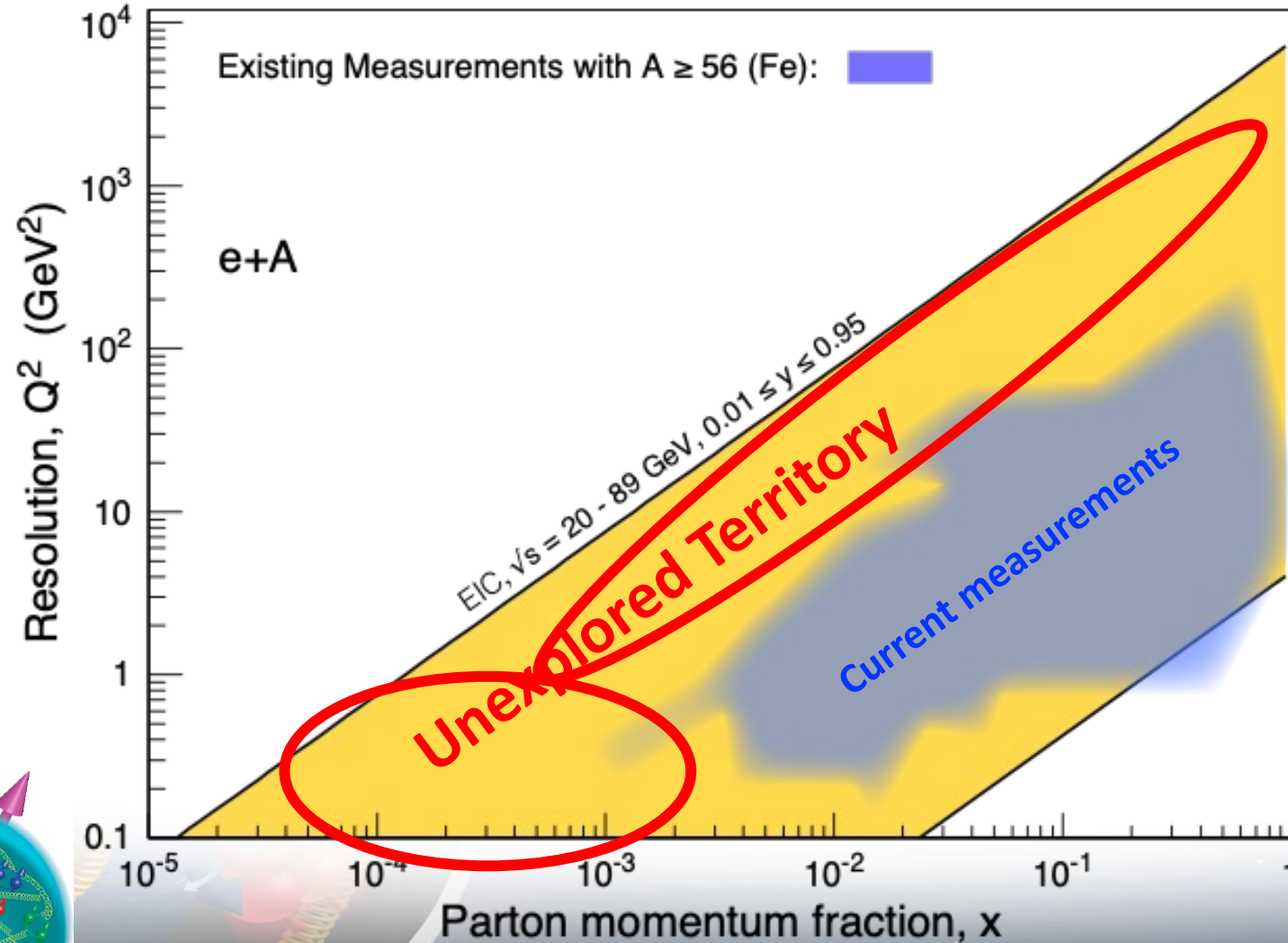

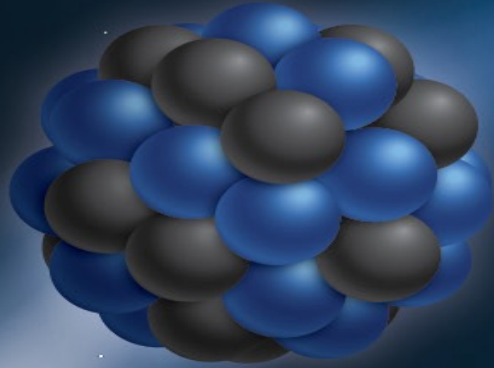

Lots of microscopes...and still  
unanswered questions?

Is there a machine that can help?

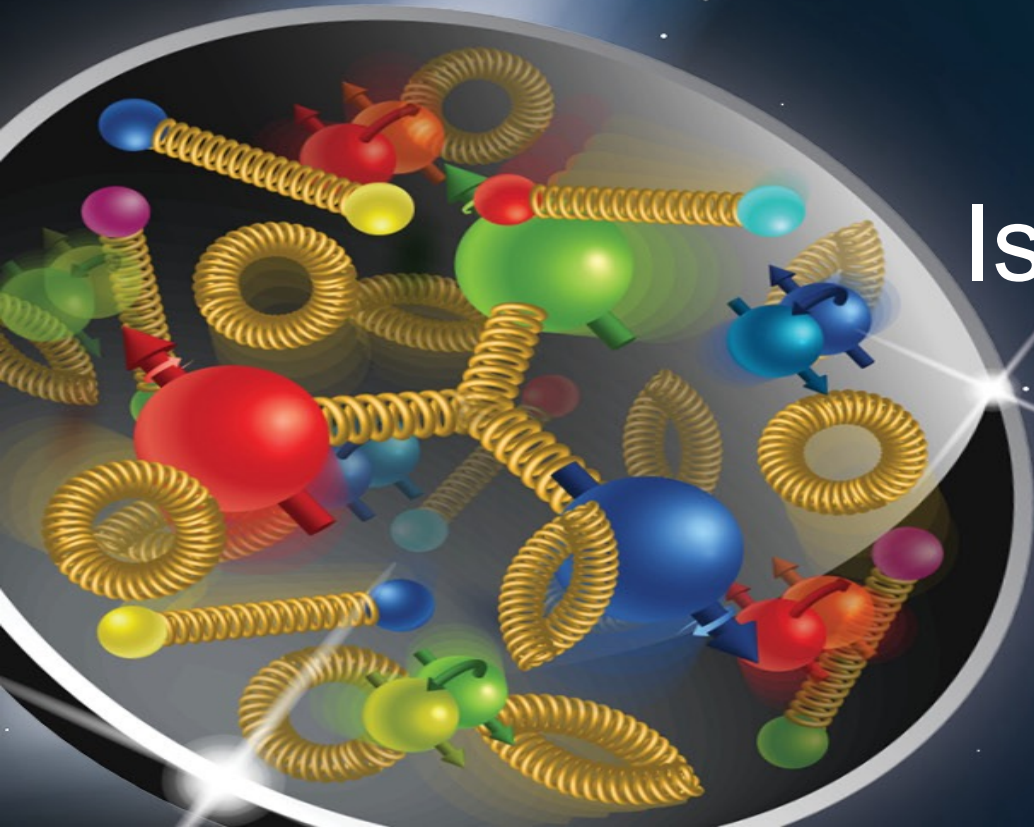

# The Electron-Ion Collider (EIC)

- Deep-Inelastic Scattering machine → **electron + proton (or nucleus) collisions.**
- Built on the infrastructure of the existing Relativistic Heavy-Ion Collider (RHIC) facility at Brookhaven Lab, in partnership with Jefferson Lab.
  - This machine combines the functionality of HERA and RHIC.

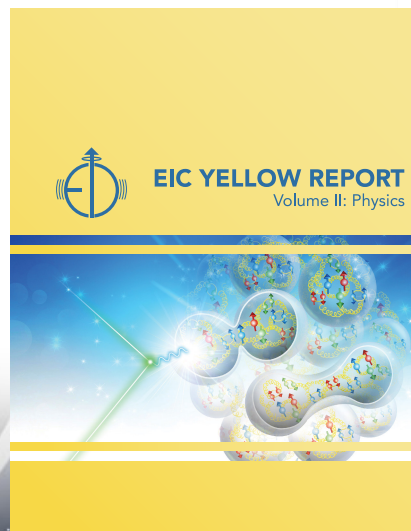
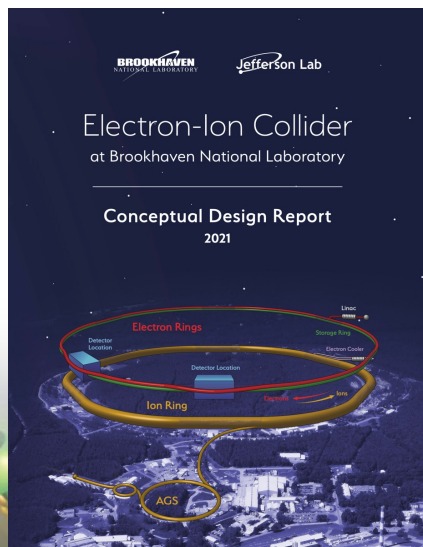
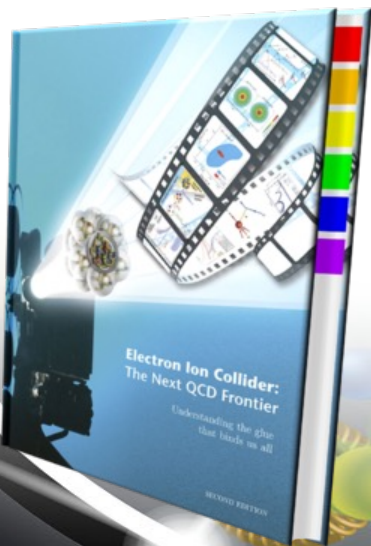
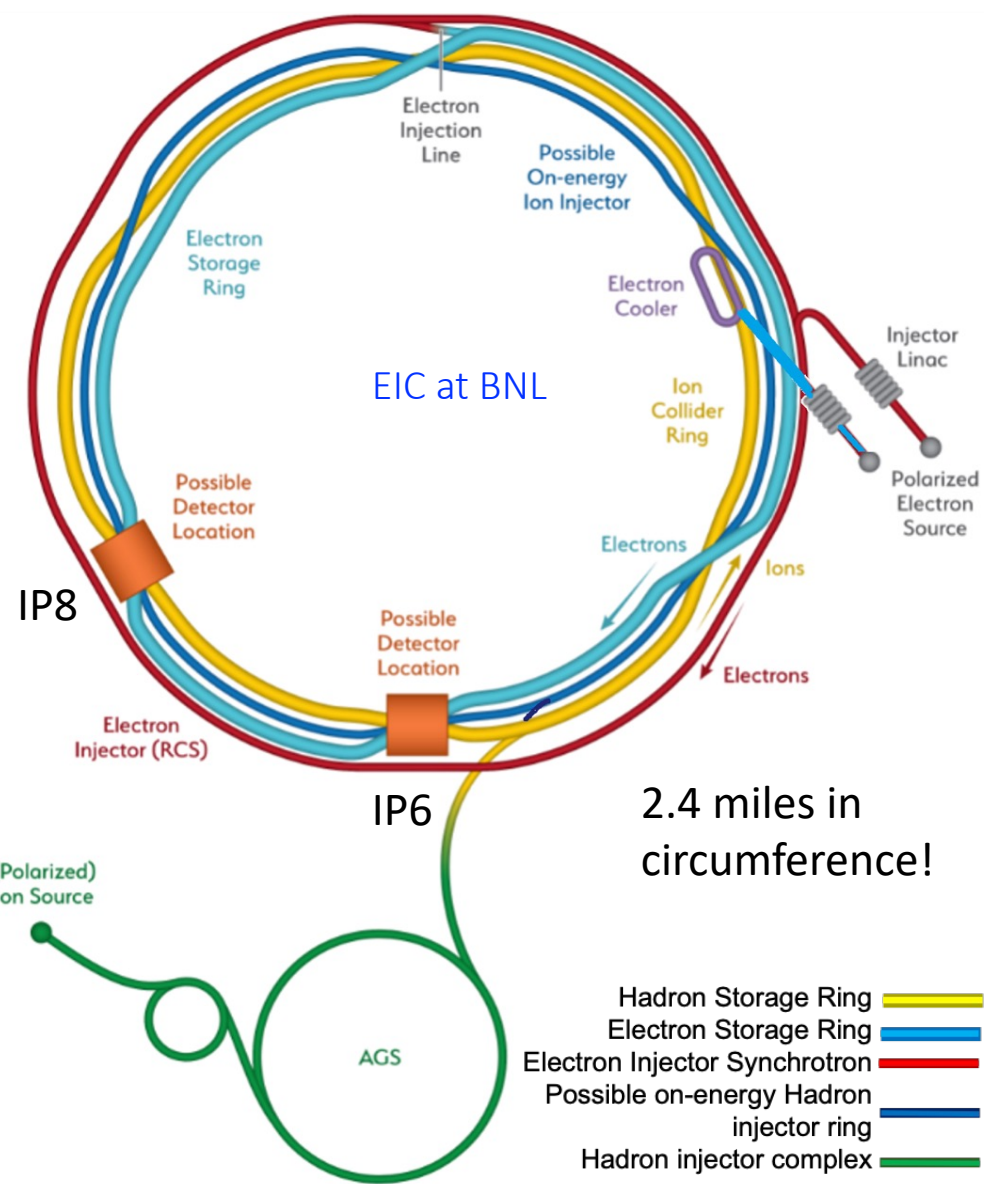

# The Electron-Ion Collider (EIC)

## What is the EIC:

A machine for colliding polarized electrons with polarized protons/light-nuclei, or unpolarized heavy-nuclei.

## What is new/different:

- A factor of 100 - 1000 higher luminosity than HERA → **more statistics, higher precision!**
- Both electrons and protons / light nuclei **polarized** → **spin-dependent observables!**
- Nuclear beams: d to U → **heavy-nuclei provide access to novel studies in QCD!**

**Data taking to start after 2030!**

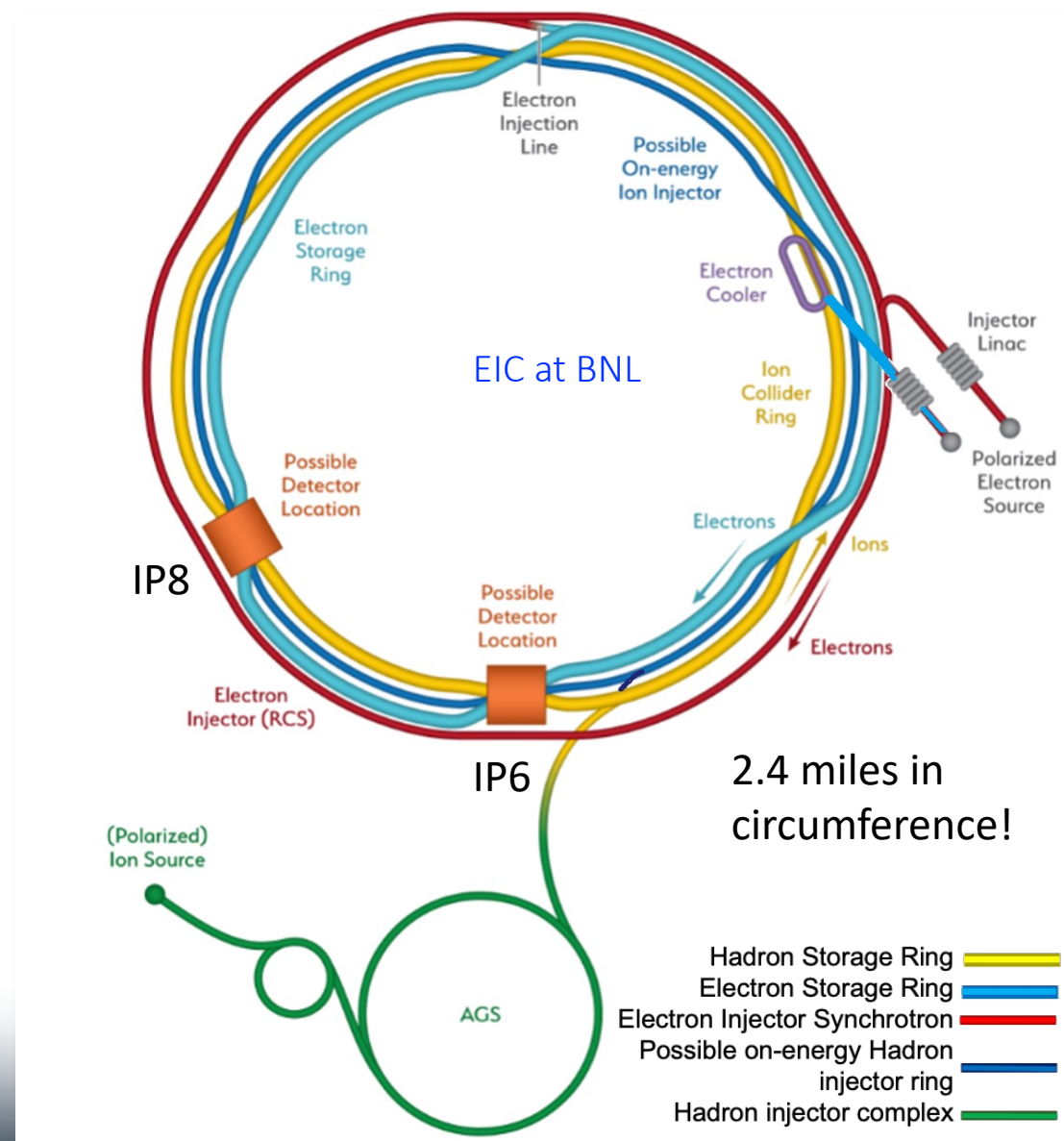

# Intermission: Cute Animals



**Julep**

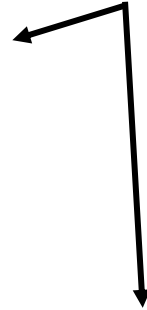

They (mostly) get along.

**Lilu**

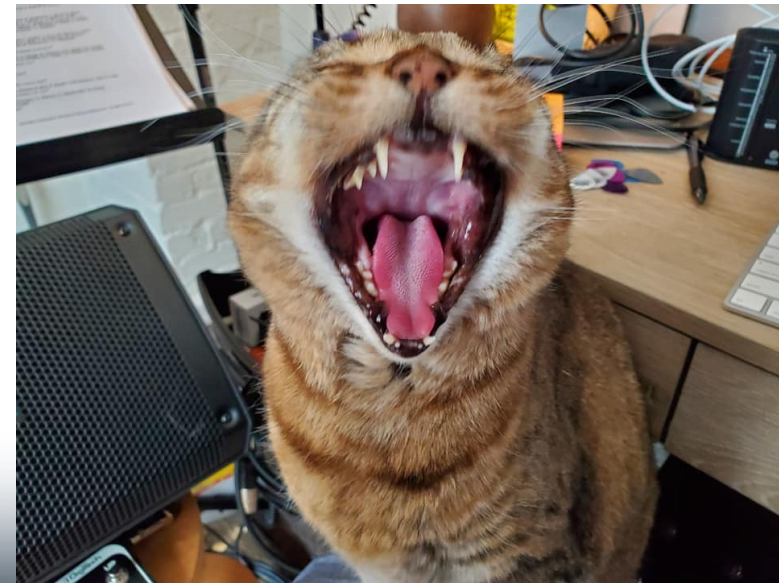
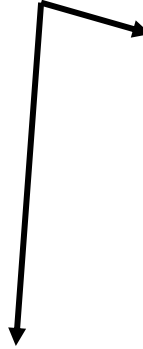

She's in a death metal band.

# More about QCD

## Universality

- QCD interactions arising from different collision systems should be *universal*.

Measurements from one collision system can inform studies on other systems!

Deep-Inelastic Scattering: e+p

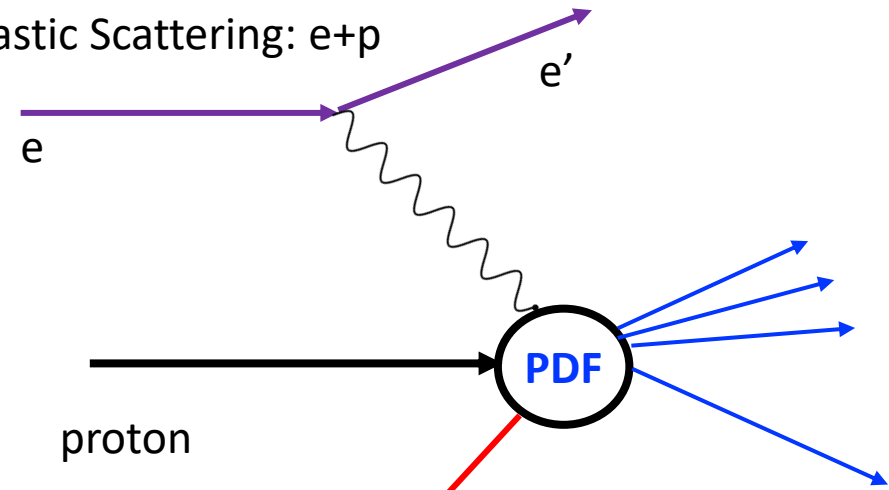

Proton + proton collision

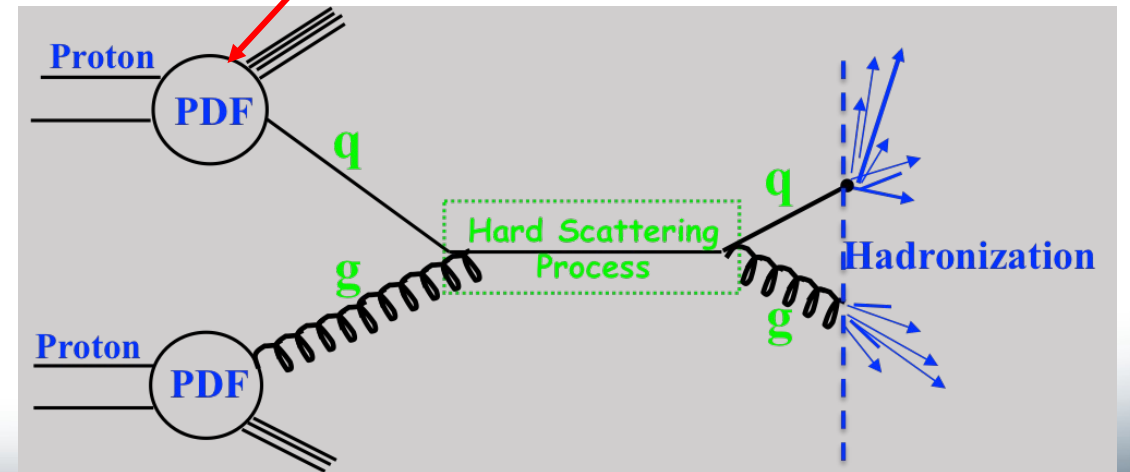

# More about QCD

QCD Interactions  $\sim$  PDF  $\otimes$  high-energy parton interaction  $\otimes$  Hadronization

high-energy parton interaction : calculable in QCD

PDFs and Hadronization: need to be determined experimentally

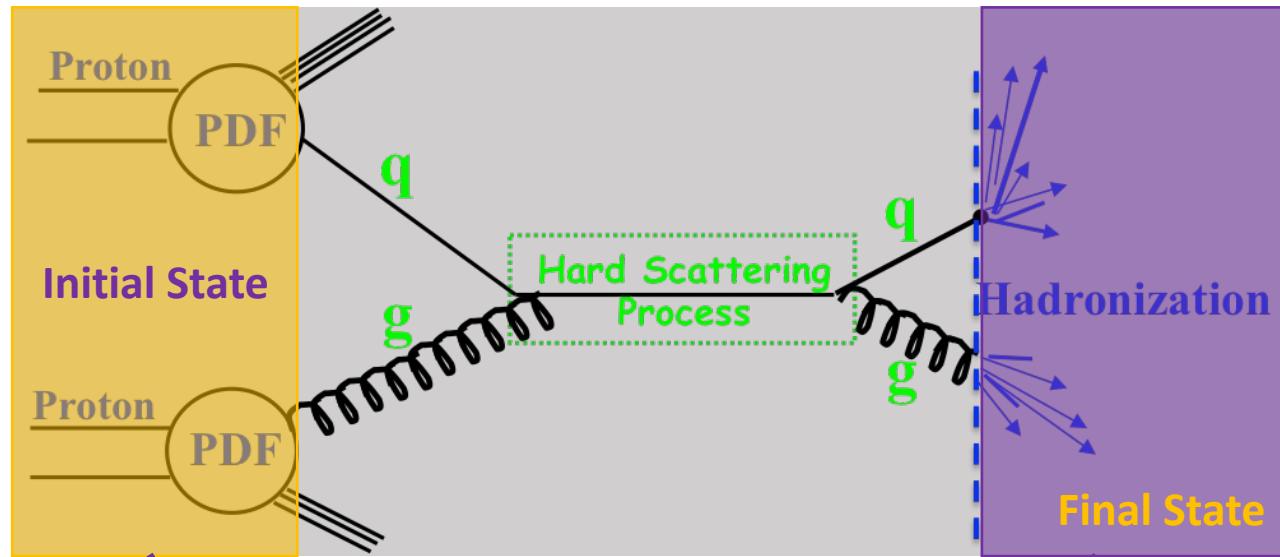

- Initial state: nuclear structure and parton distributions

- How does the initial distribution of partons (PDF) affect the interaction?
  - Protons vs. nuclei?
- How does polarization (spin) modify these distributions?  $\rightarrow$  **Proton spin puzzle!**

- Final state: Fragmentation & Hadronization

- How do the produced partons fragment and hadronize into the particles we measure?
- **Hadronization** can aid in our understanding of **confinement** in QCD.



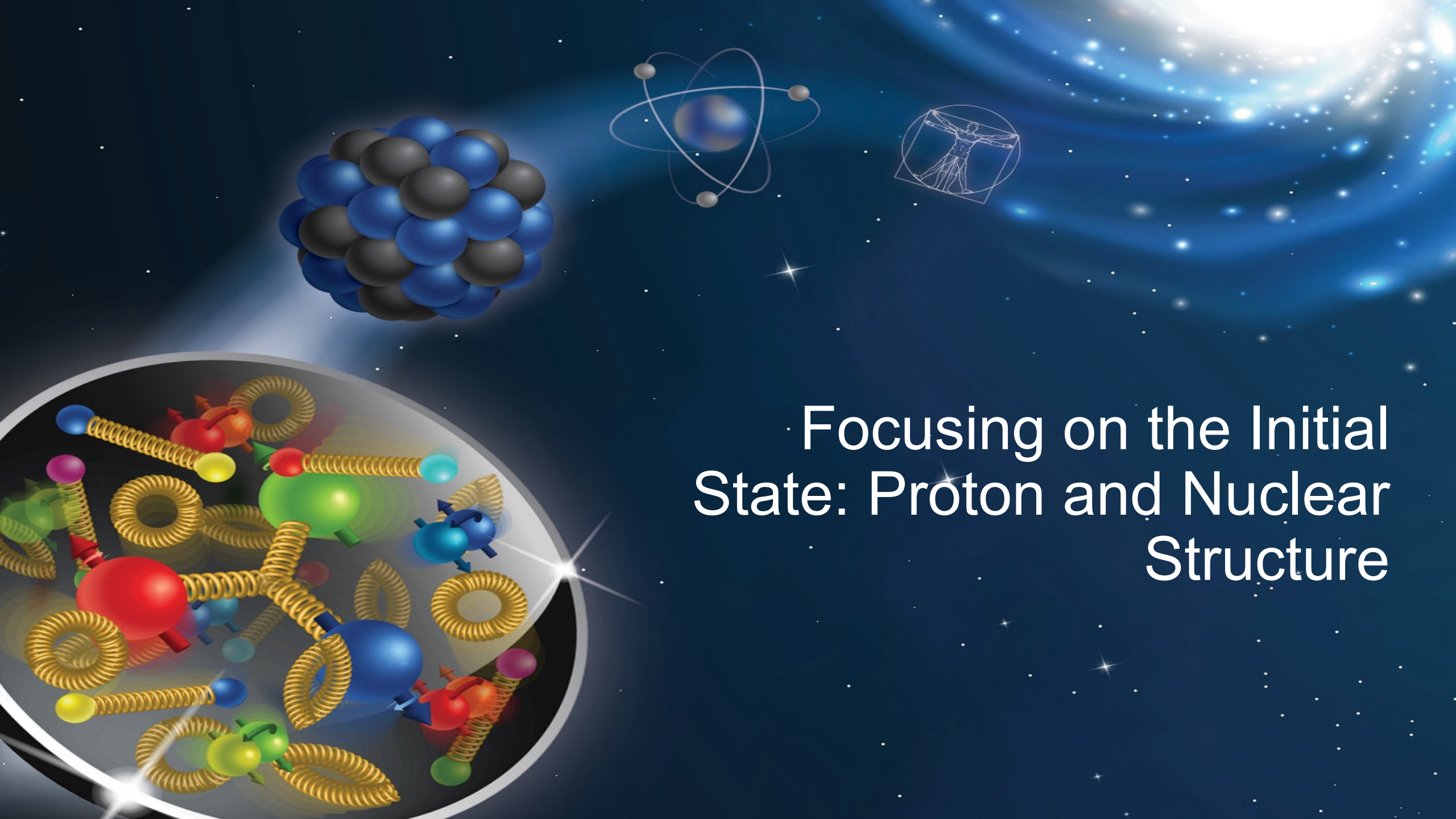

Focusing on the Initial State: Proton and Nuclear Structure

# Quantifying proton structure – structure functions

Gluons manifest themselves through

- the behavior of the cross section as function of  $x$  and  $Q^2$
- without gluons the cross section depends **only** on  $x$ , no dependence on  $Q^2 \rightarrow F_2(x)$

$$\text{cross section} \sim \alpha F_2(x, Q^2) + \beta F_L(x, Q^2)$$

quark+anti-quark  
momentum distributions

gluon momentum  
distribution

$F_2$  and  $F_L$  - “structure functions”

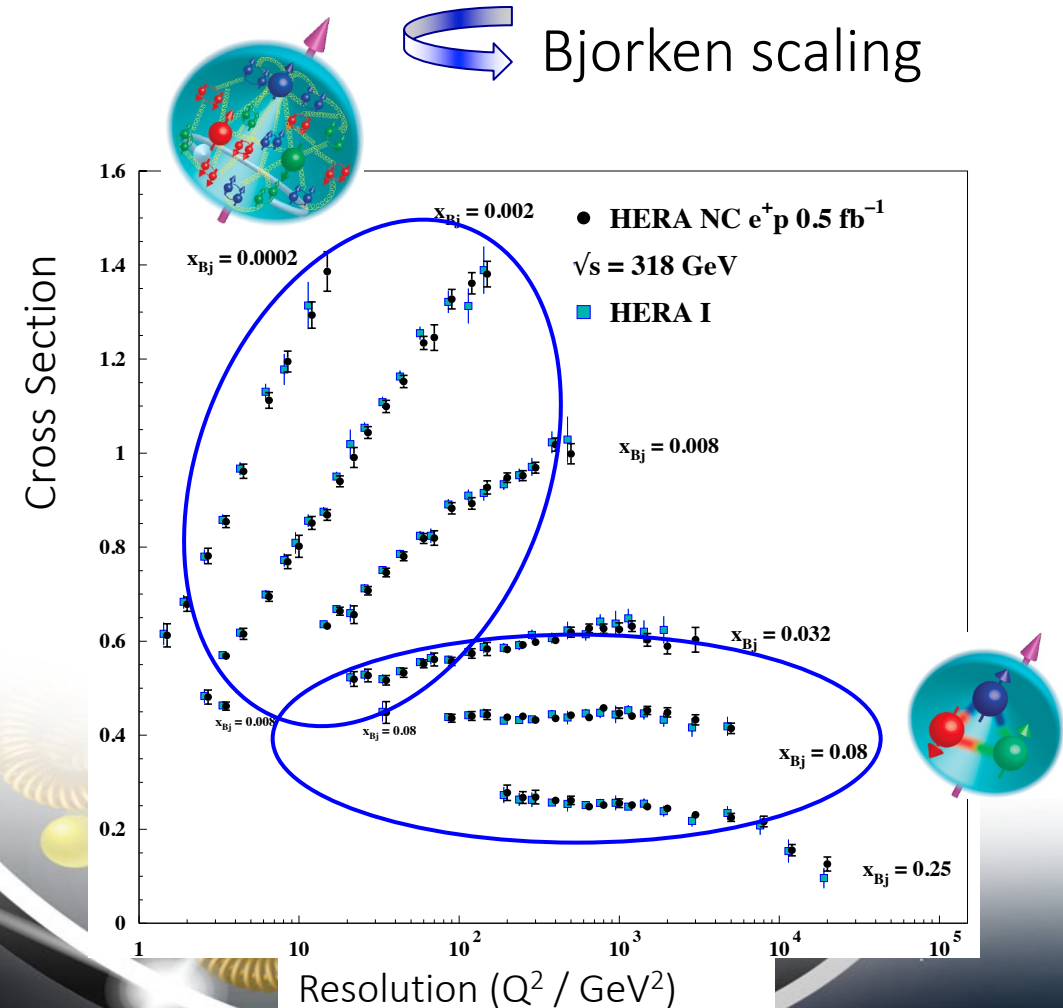

“cross section” – essentially a probability for an event.  
**DIS cross section**  $\times$  **luminosity** = **DIS event rate**

**BUT:** (e.g. number of collisions per second)

Observe strong rise of cross section with both  $x$  and  $Q^2$

Because of gluon-initiated processes

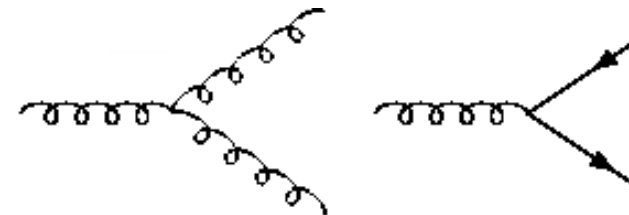

**EIC:**

- How are the structure functions modified in nuclei?
- Spin dependence?
- Protons vs. neutrons?

# Neutron Structure Functions

EIC enables use of deuteron beams → the next best thing to a beam of neutrons!

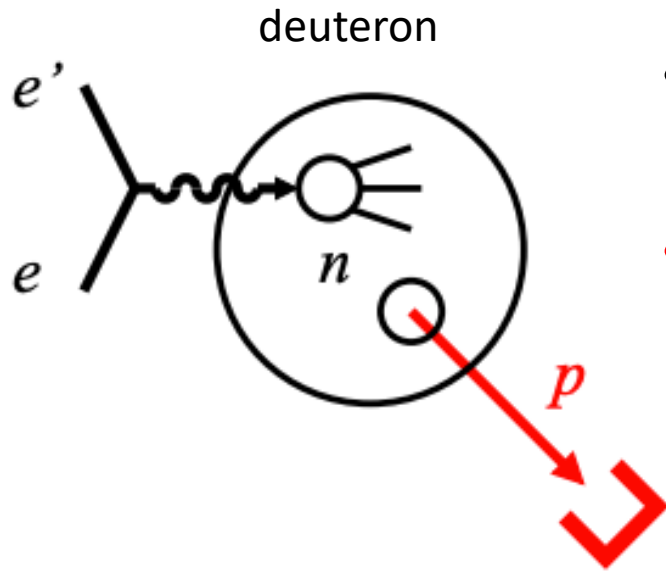

- Measurements on unpolarized deuterons<sup>1</sup> (or polarized He-3)<sup>2</sup> at the EIC.
- **Spectator** proton momentum → enables selection of nuclear (p/n) configurations.
  - Extract **free neutron** structure function<sup>3</sup> → **Not possible elsewhere!**
  - Study nuclear modifications of both nucleons in the deuteron (**study in progress**).

[1] Z. Tu, A. Jentsch, et al., Physics Letters B, (2020)

[2] I. Friscic, D. Nguyen, J. R. Pybus, A. Jentsch, *et al.*, Phys. Lett. B, **Volume 823**, 136726 (2021)

[3] A. Jentsch, Z. Tu, and C. Weiss, Phys. Rev. C **104**, 065205, (2021) (**Editor's Suggestion**)

# What about nuclei?

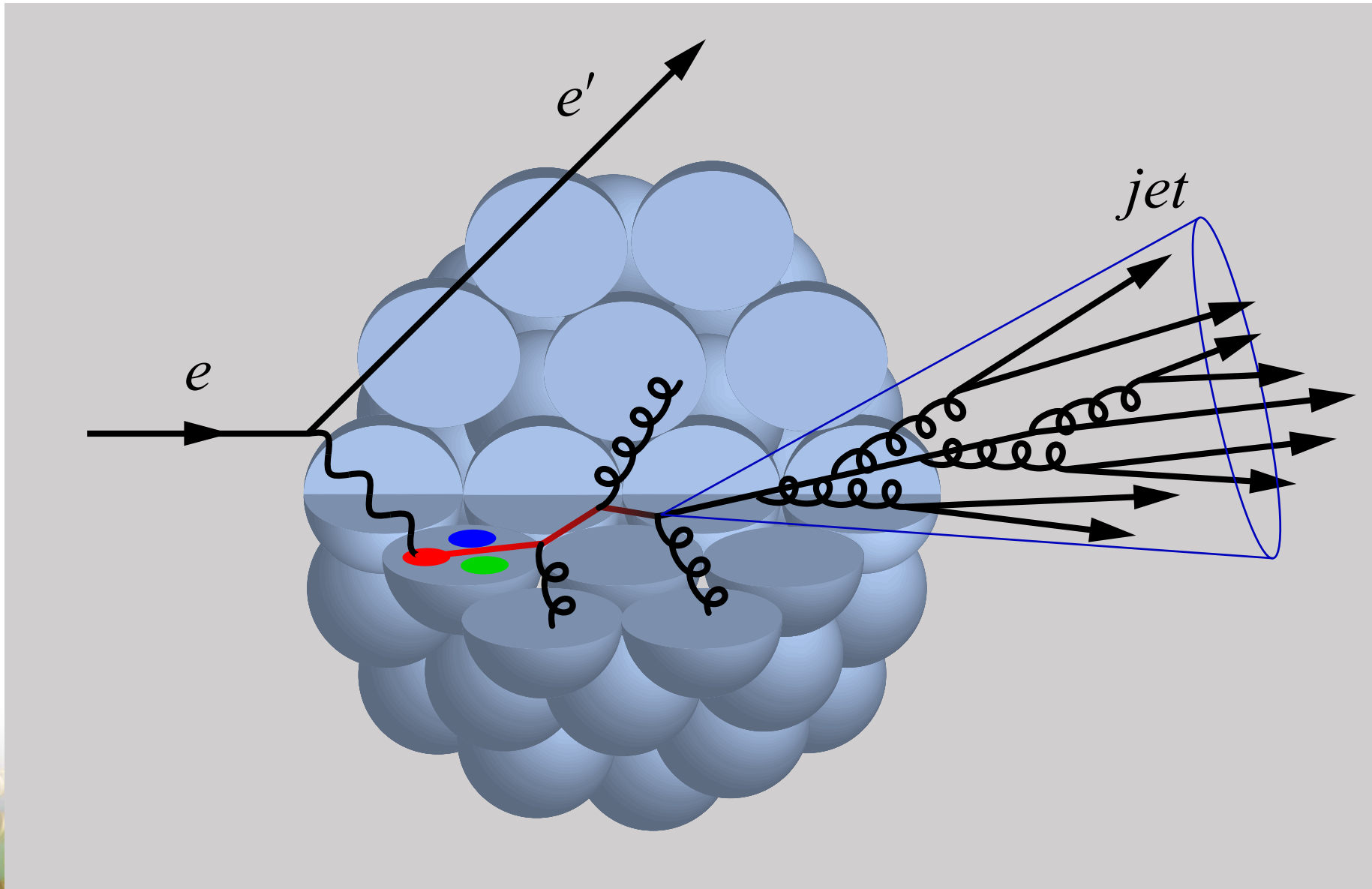

# Nuclear Parton Distribution Functions

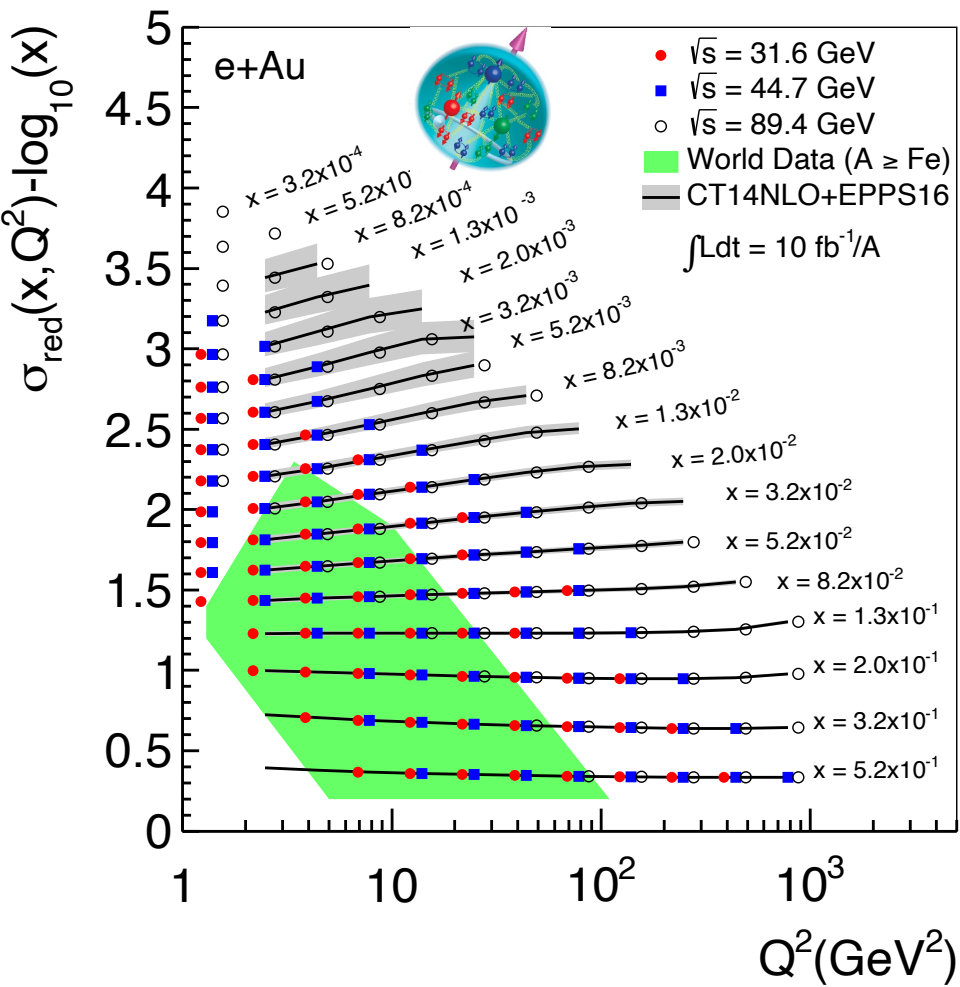

More data from EIC  
 =  
 Better constraints on nPDFs

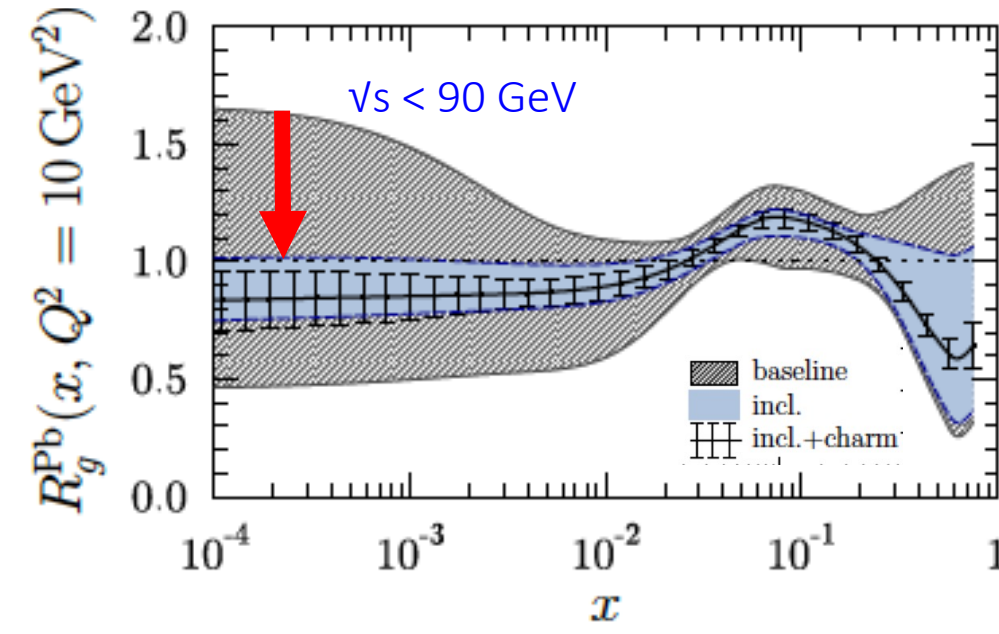
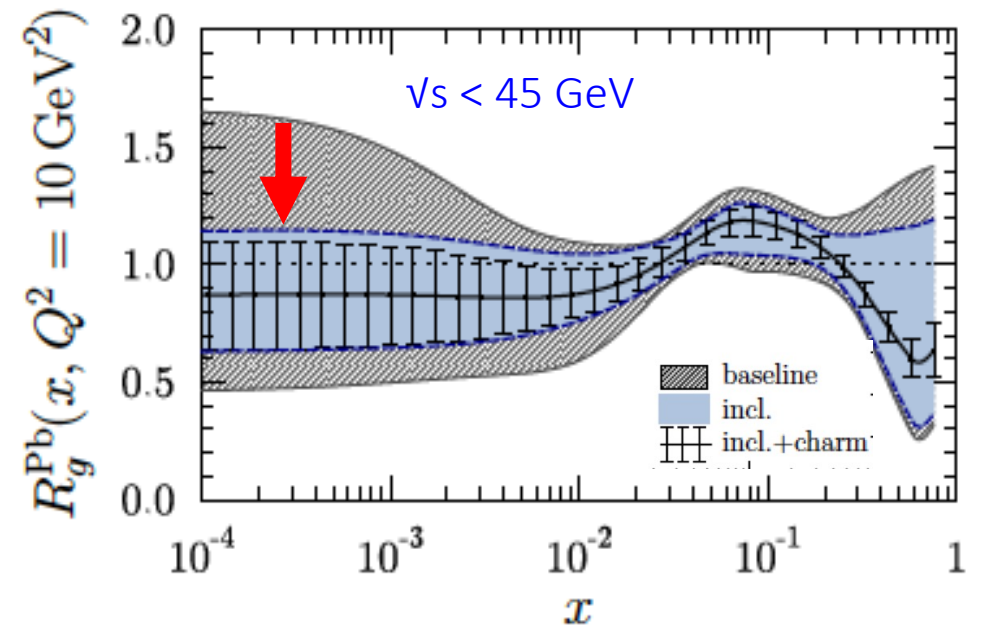
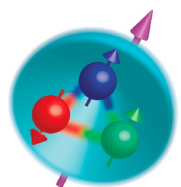

E. C. Aschenauer, S. Fazio, M. A. C. Lamont, H. Paukkunen, and P. Zurita  
 Phys. Rev. D **96**, 114005 (2017)

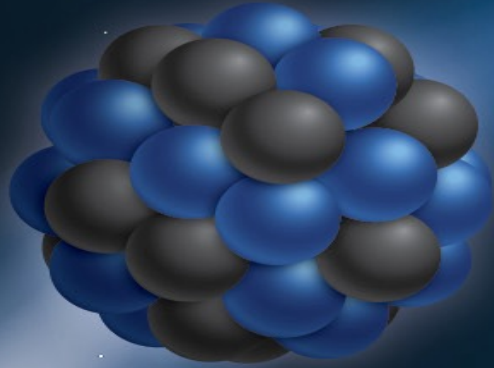

So, how do we take pictures  
of the collisions at the EIC?  
What is our *microscope*?

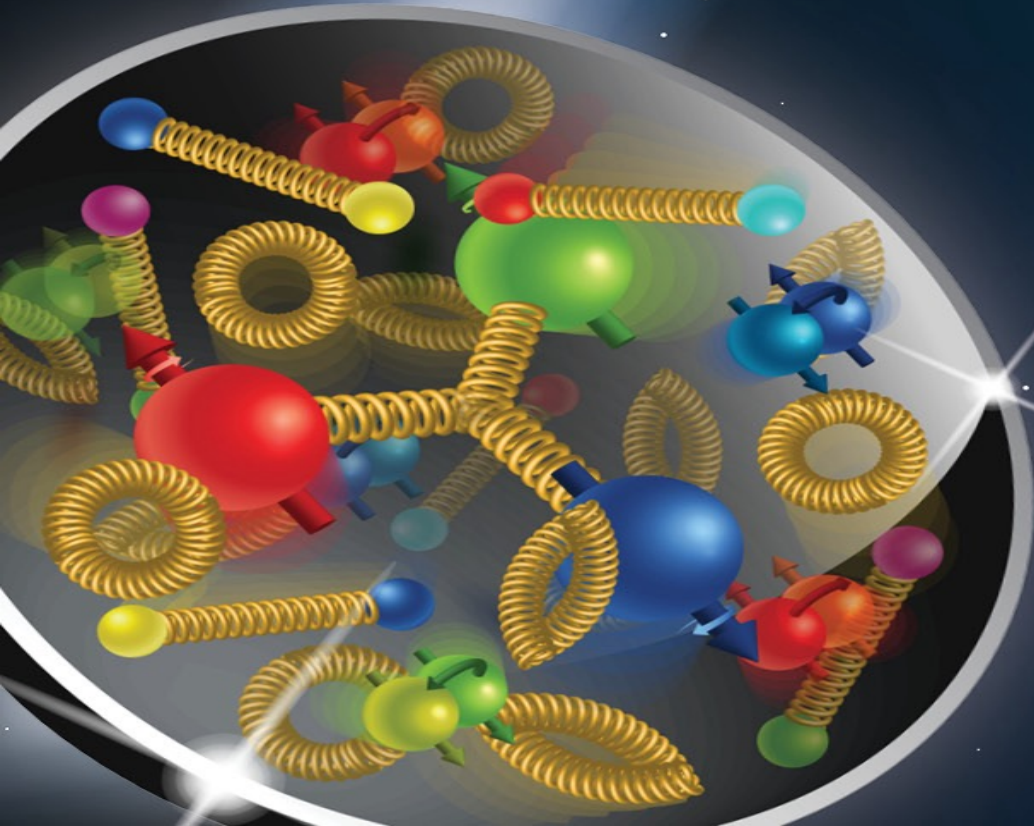

# The ePIC Detector

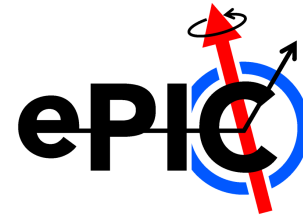

- hadronic calorimeters
- solenoid coils
- e/m calorimeters
- MAPS tracker
- MPG trackers
- ToF, DIRC, RICH detectors

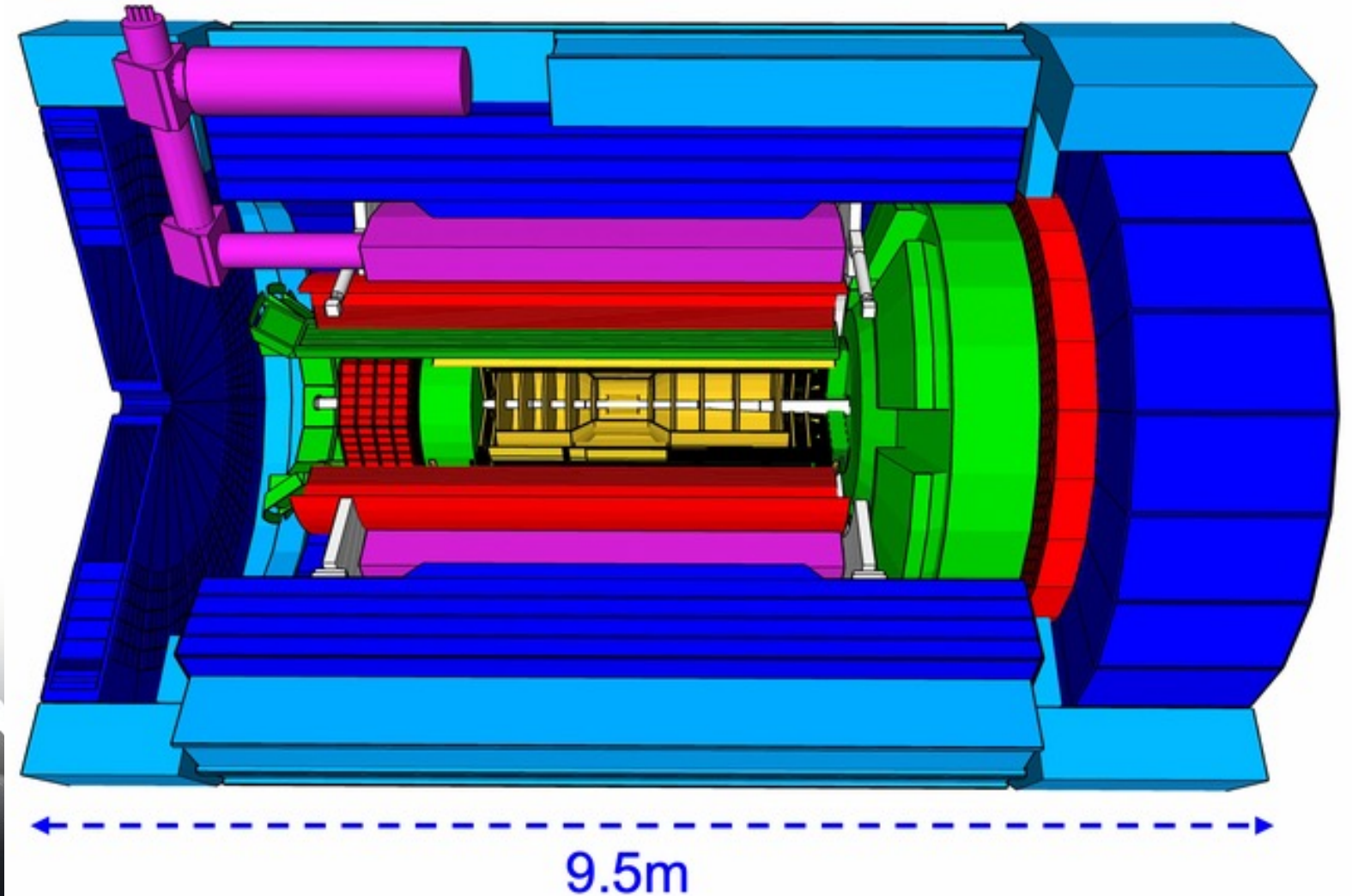

# The ePIC Detector

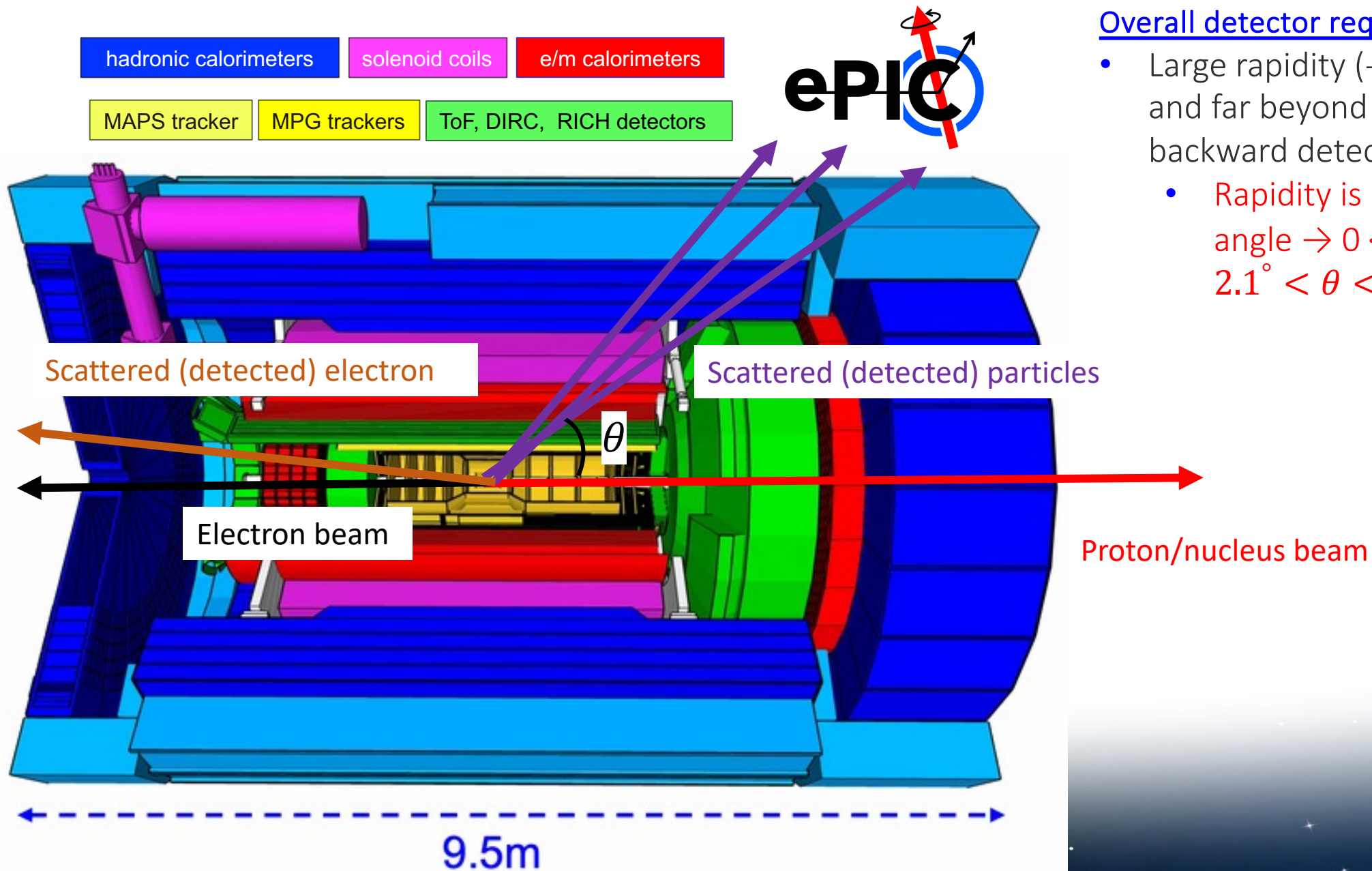

## Overall detector requirements:

- Large rapidity ( $-4 < \eta < 4$ ) coverage; and far beyond in far-forward/far-backward detector regions
  - Rapidity is related to the polar angle  $\rightarrow 0 < \eta < 4$  equates to  $2.1^\circ < \theta < 90^\circ$



# The ePIC Detector

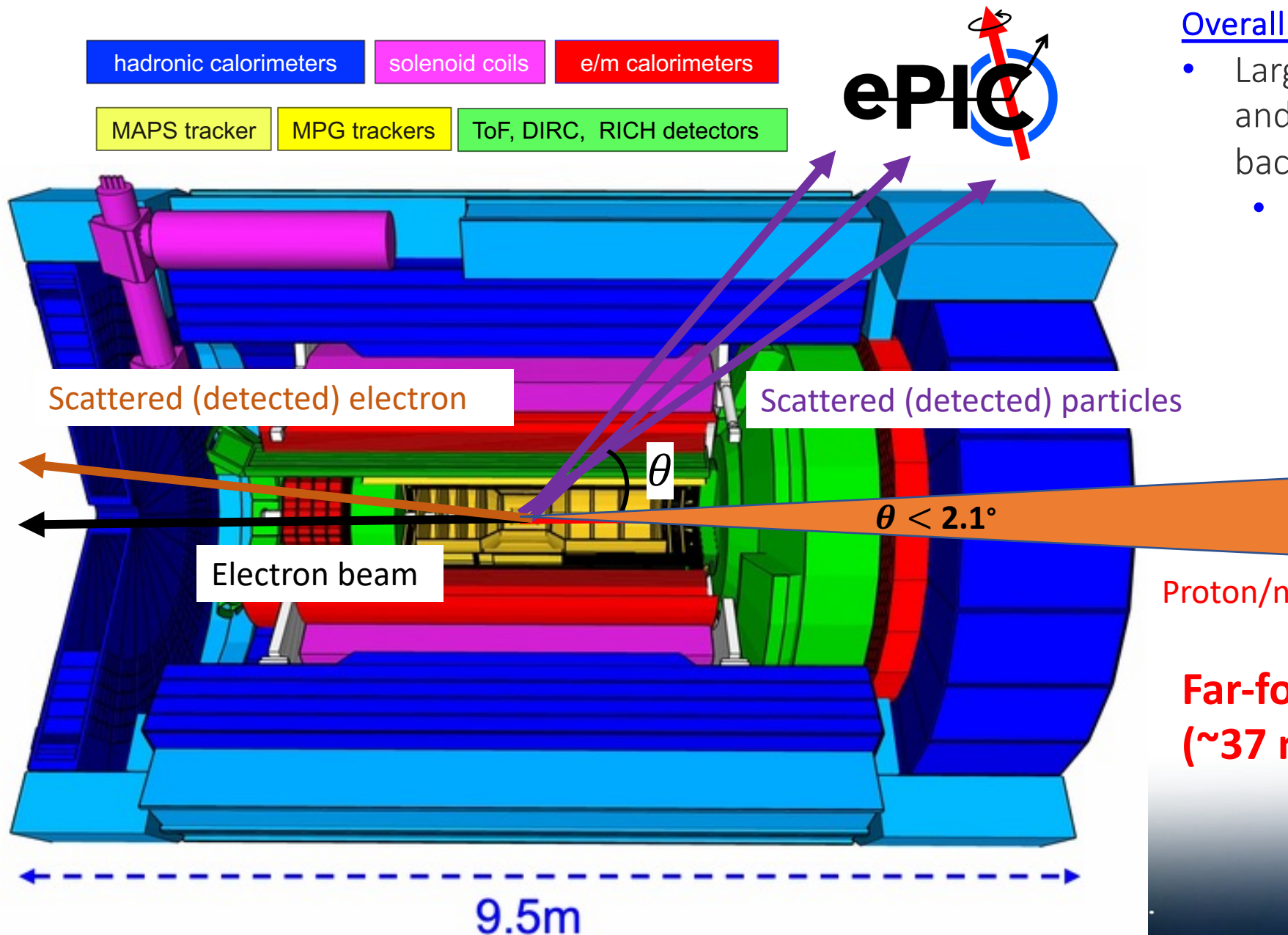

## Overall detector requirements:

- Large rapidity ( $-4 < \eta < 4$ ) coverage; and far beyond in far-forward/far-backward detector regions
  - Rapidity is related to the polar angle  $\rightarrow 0 < \eta < 4$  equates to  $2.1^\circ < \theta < 90^\circ$

Proton/nucleus beam

**Far-forward here means  $\theta < 2.1^\circ$   
( $\sim 37$  mrad)**

# The ePIC Detector

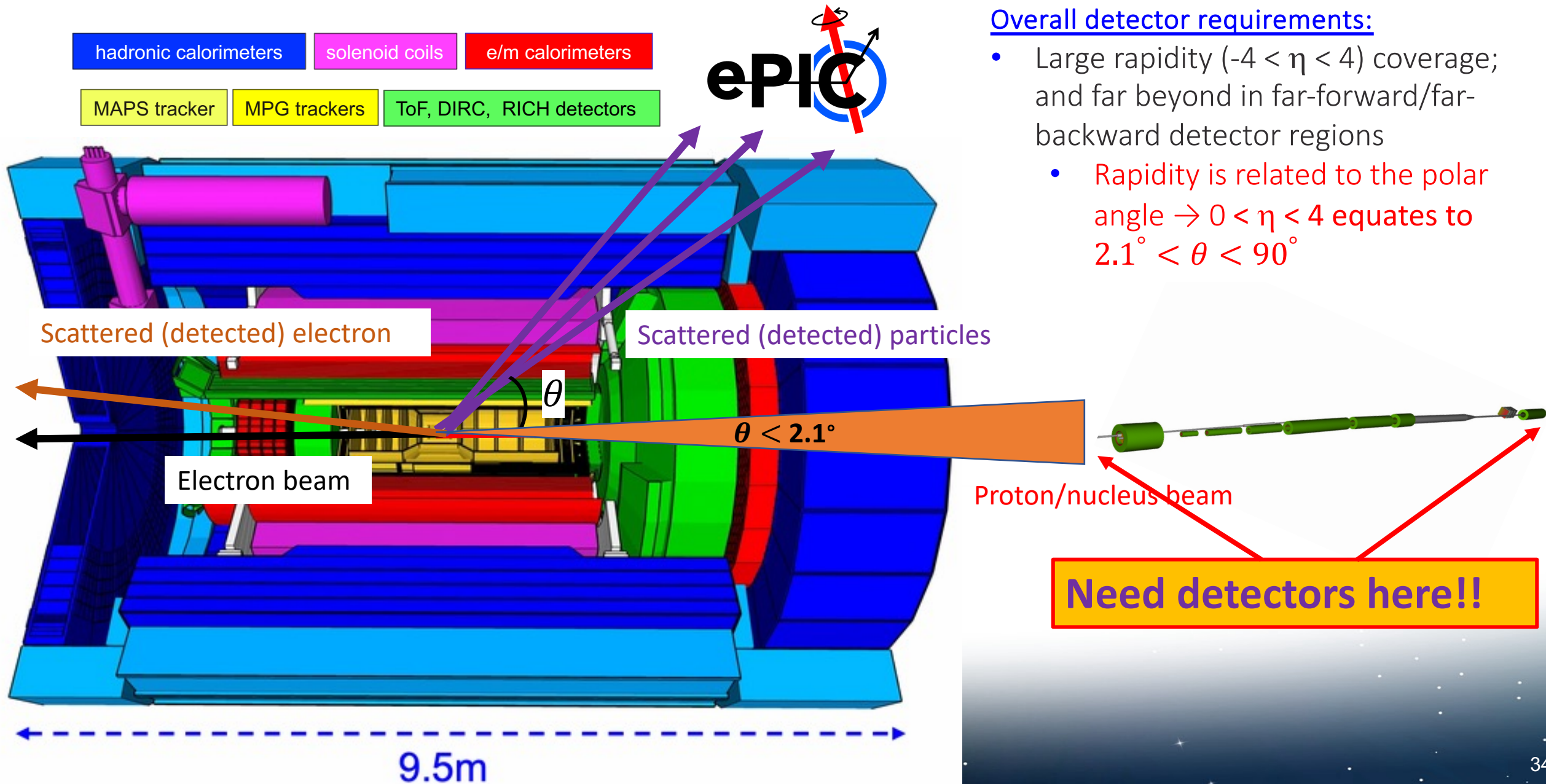

## Overall detector requirements:

- Large rapidity ( $-4 < \eta < 4$ ) coverage; and far beyond in far-forward/far-backward detector regions
  - Rapidity is related to the polar angle  $\rightarrow 0 < \eta < 4$  equates to  $2.1^\circ < \theta < 90^\circ$

# The EIC detector(s)

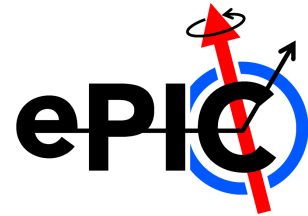

- Two interaction regions (IRs) for possible detector locations.
  - Only one IR (IP6) part of the project scope.

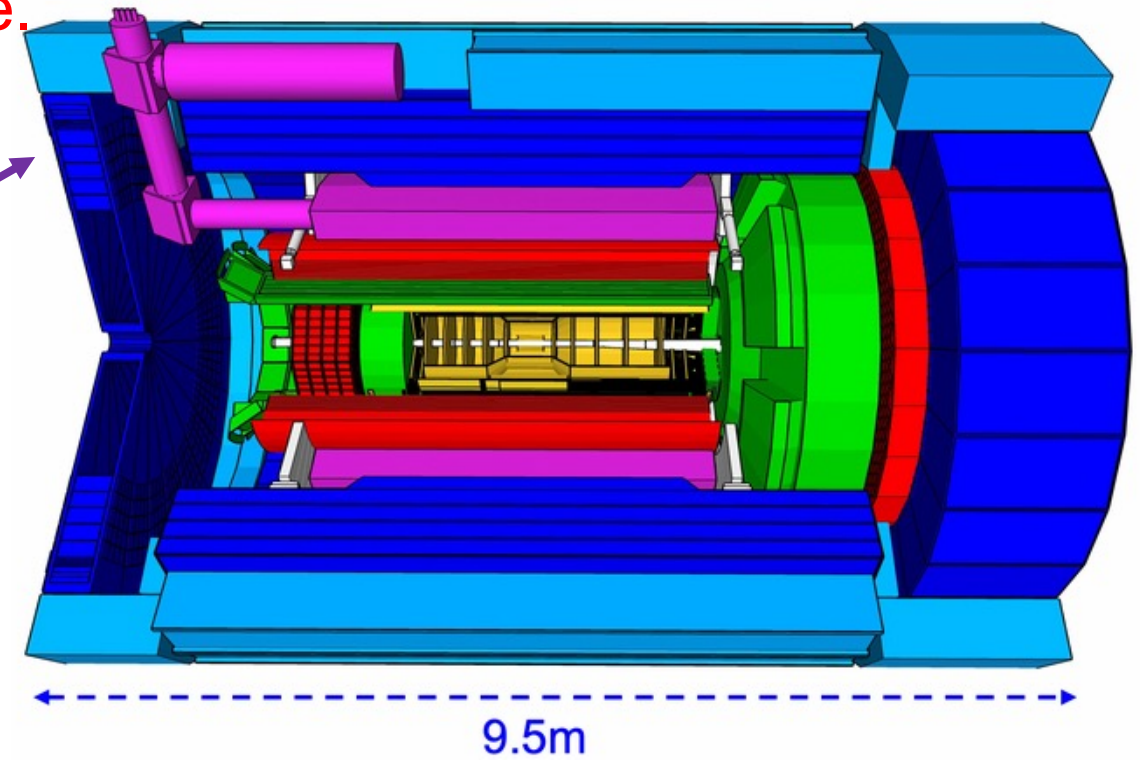
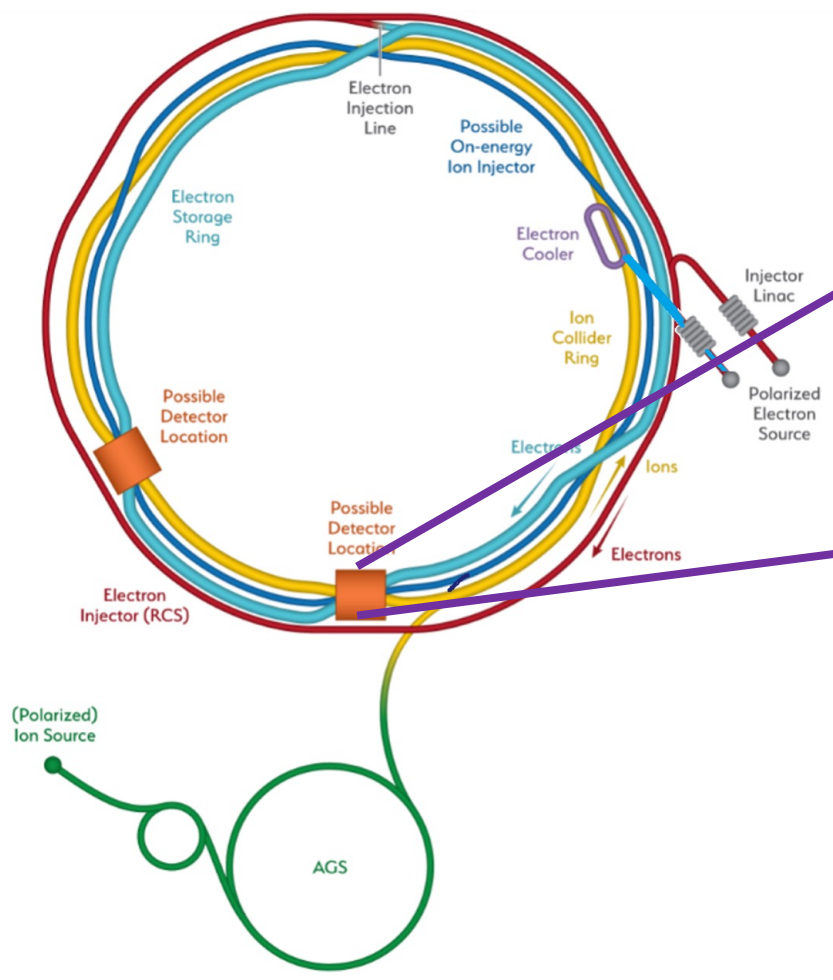

- ePIC detector based around a 1.7T solenoid magnet.
- Contains subdetectors for tracking, PID, and calorimetry.

# The Interaction Region (IR6)

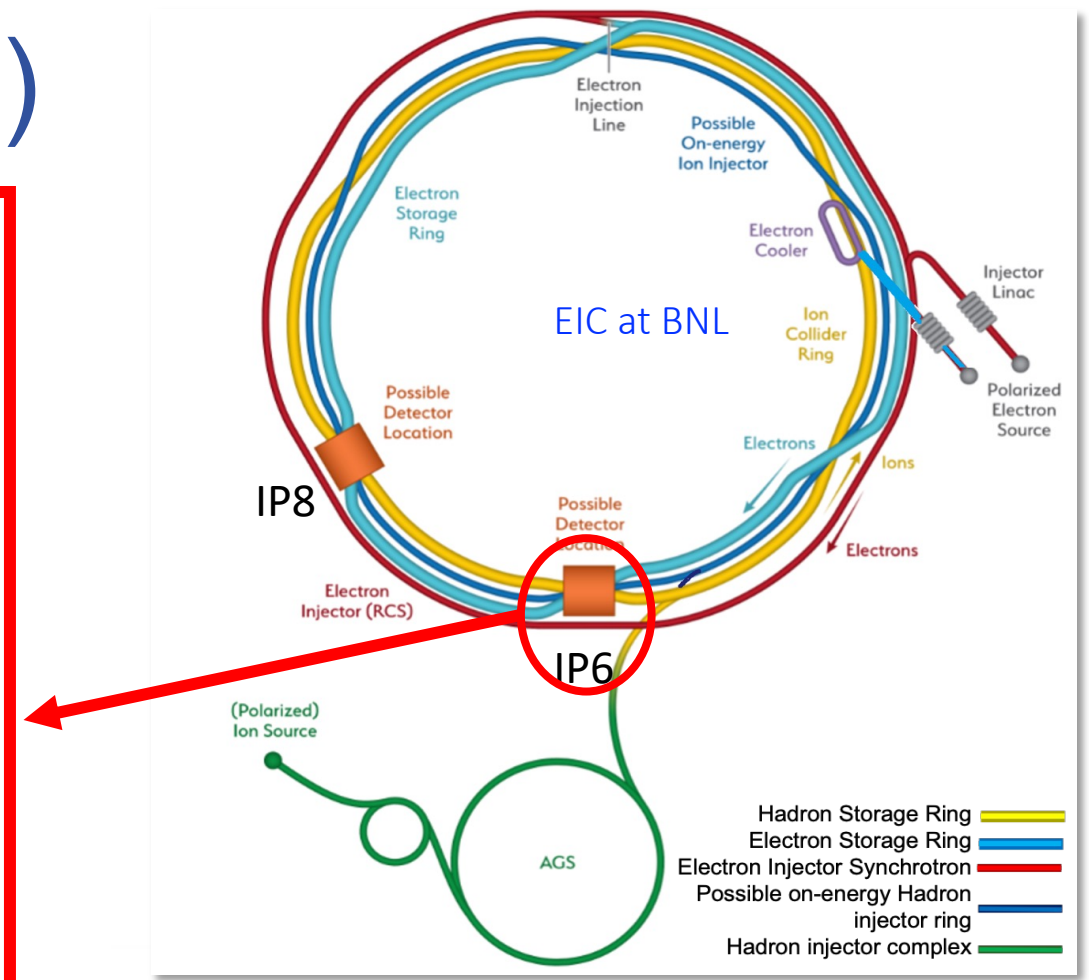
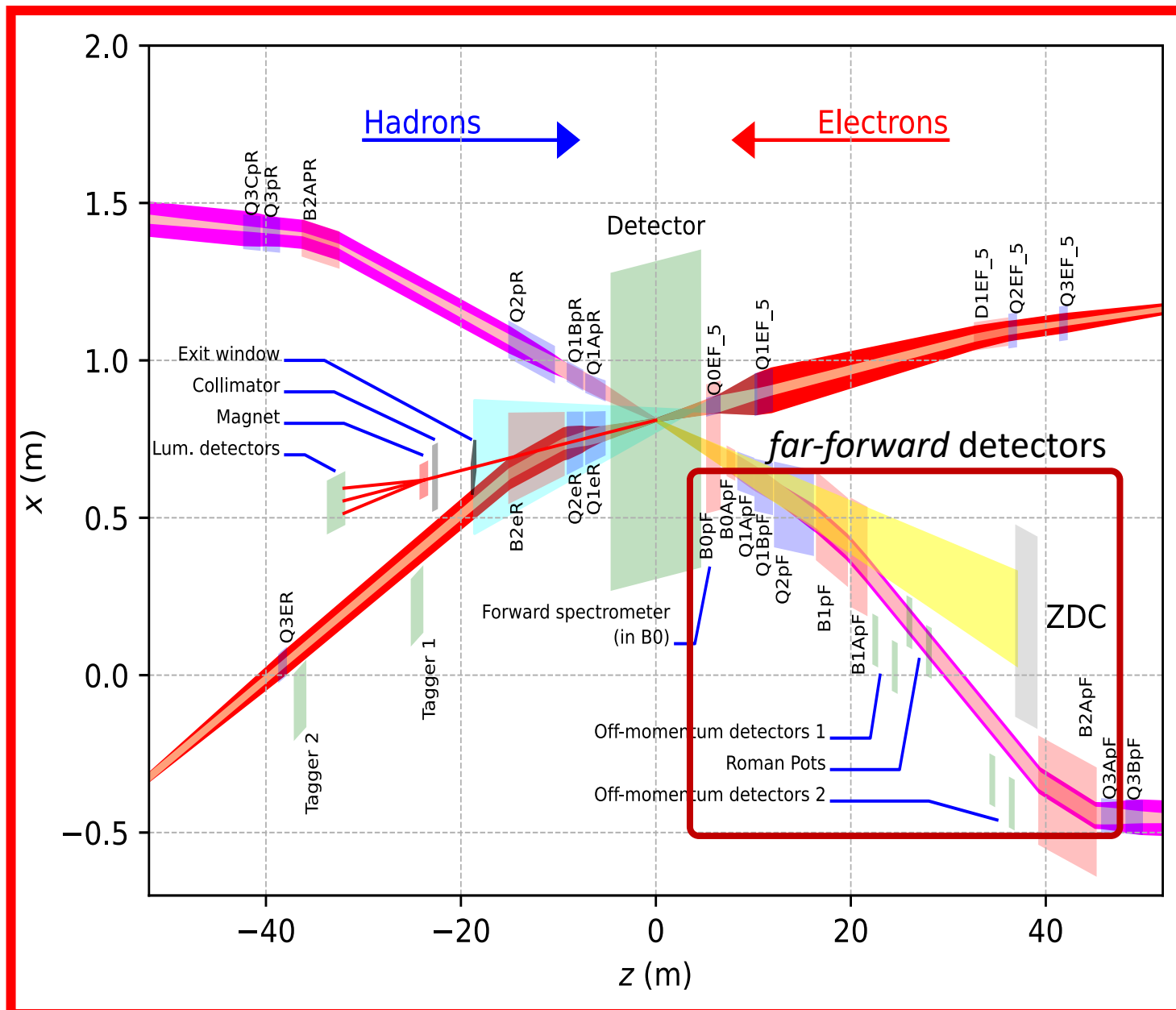

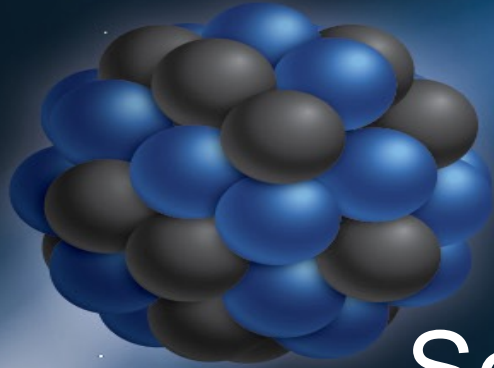

So, the EIC seems far away...what  
else can we do NOW?  
(we are impatient, after all)

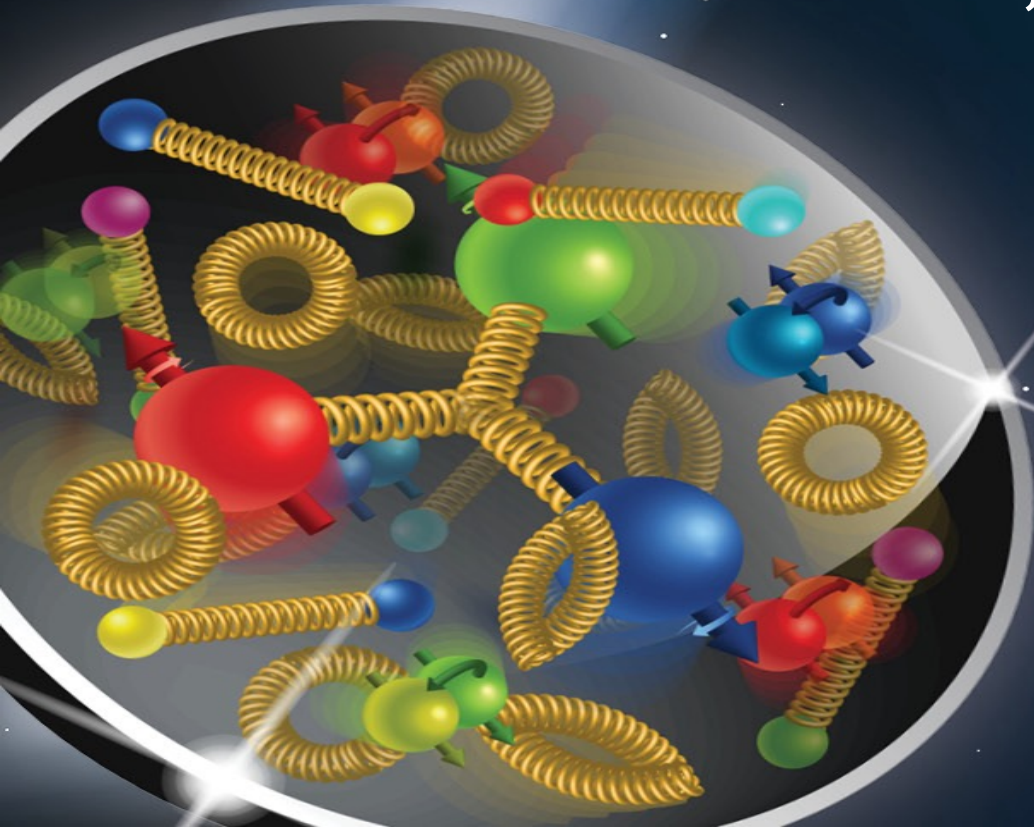

# Relative The **STAR** Detector

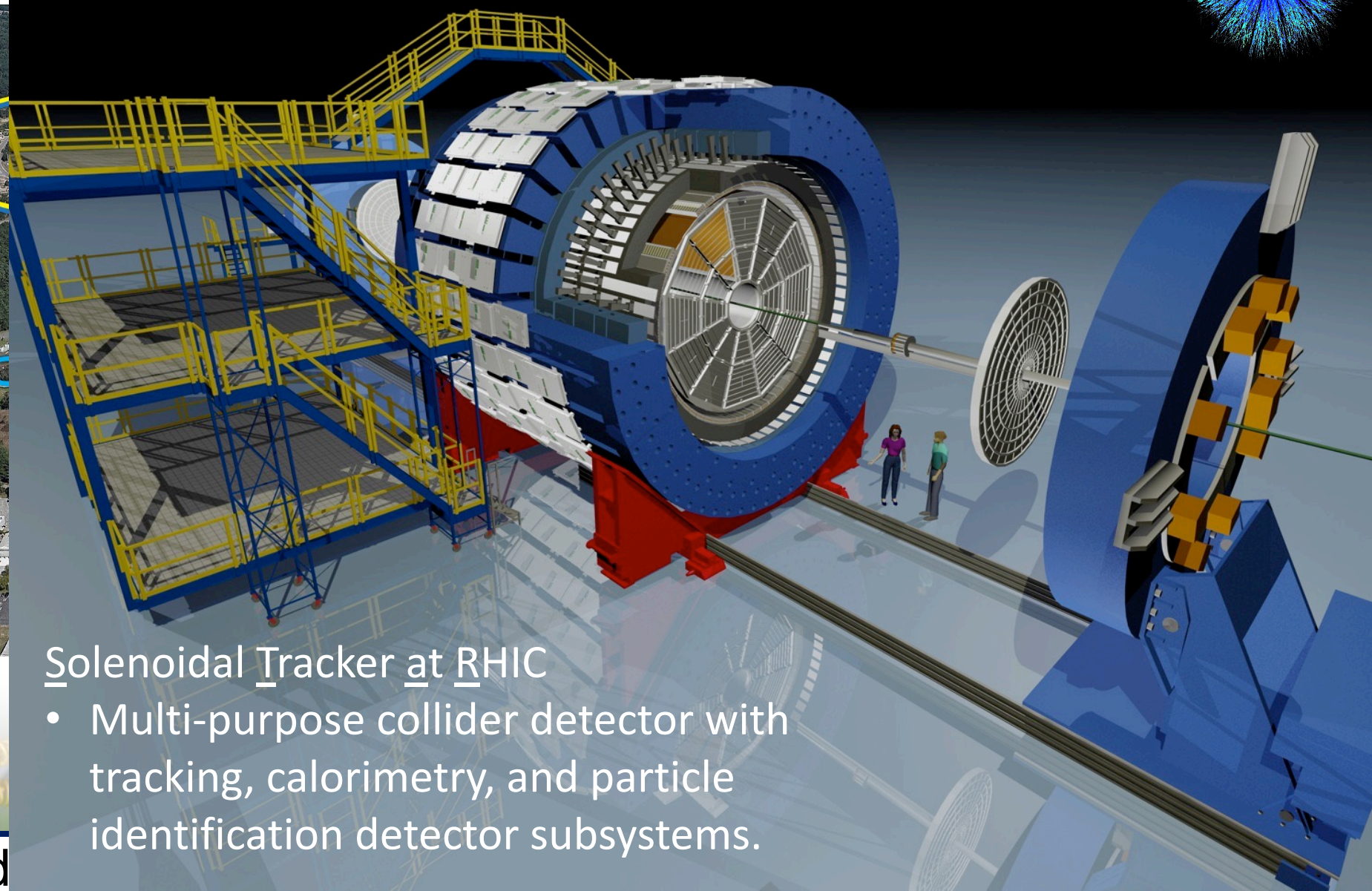
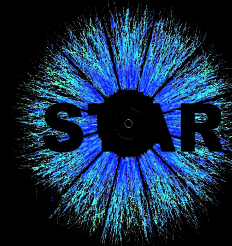

species  
neutron,  
p, p+Au

Collider on

## Solenoidal Tracker at RHIC

- Multi-purpose collider detector with tracking, calorimetry, and particle identification detector subsystems.

• Located

nd).

# Physics of RHIC – Hot and Cold QCD

Hot vs. Cold QCD – refers to temperature. All of the physics we have been talking about has been “cold”.

## “Hot” QCD

- Studies of hot, dense environment formed in **heavy-ion (e.g. Au+Au) collisions!**
- Extreme form of QCD matter → the **Quark-Gluon Plasma** → a “soup” of deconfined quarks and gluons.

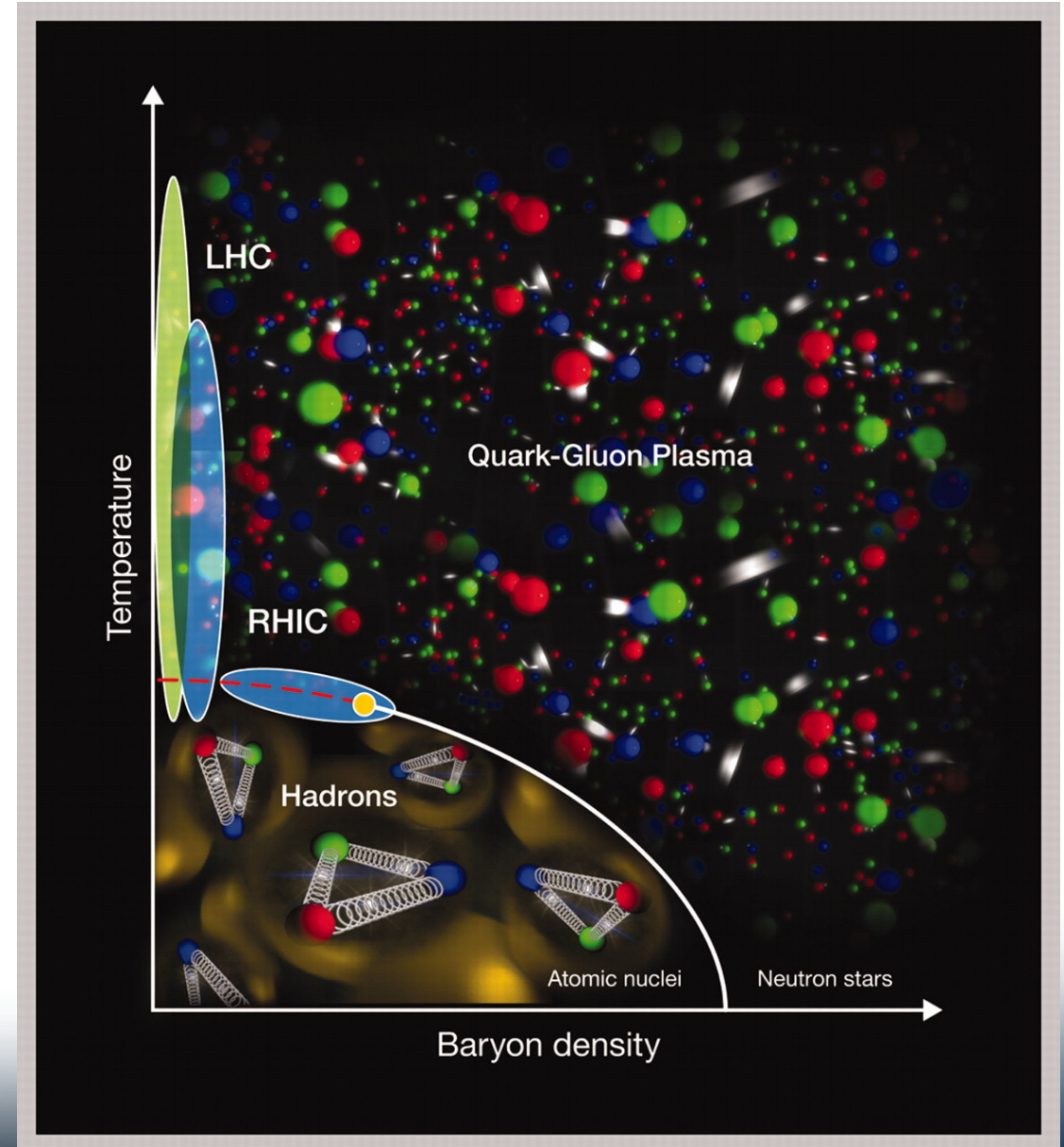
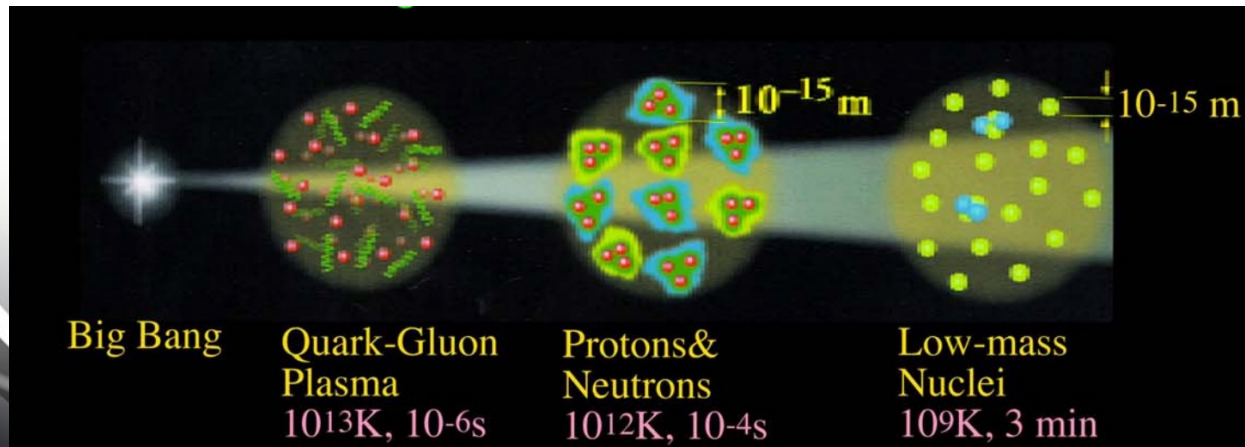

# Physics of RHIC – Hot and Cold QCD

“Cold” QCD

RHIC Cold QCD  $\Leftrightarrow$  EIC physics

Universality!! – We are impatient, but we also need the RHIC data to fully utilize the EIC data!

Lots of un-analyzed RHIC Cold QCD data (e.g. 2017 data), and more datasets being collected NOW!

Polarized proton + proton collisions

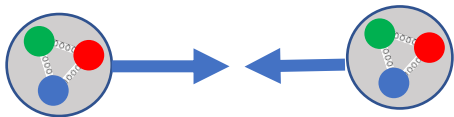

- Proton spin (gluon contribution).

proton + nucleus collisions

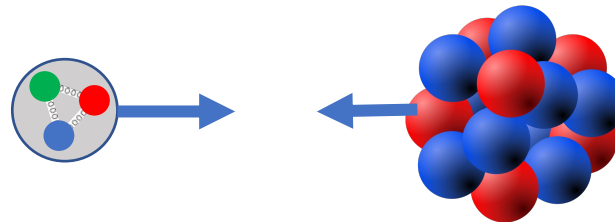

- Hints of saturation?
- Nuclear PDFs.

Ultra-Peripheral Au + Au (or p+p, p+A) collisions

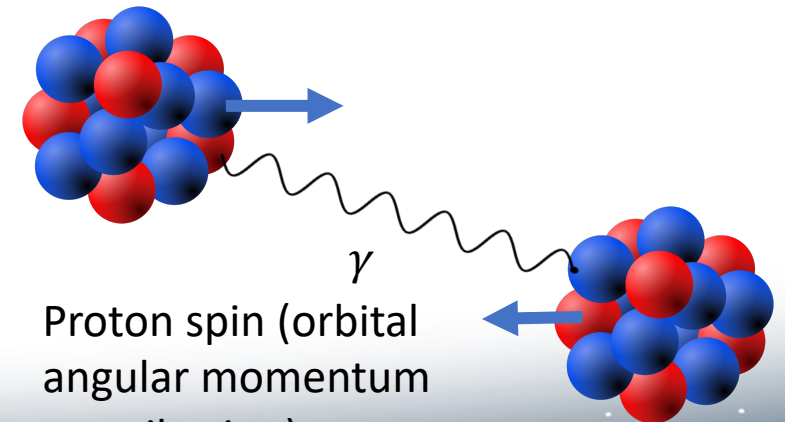

- Proton spin (orbital angular momentum contribution).



# Looking Forward: The STAR Forward Upgrade

- Addition of silicon tracking system and EM and hadronic calorimetry → forward rapidity coverage.
  - **More coverage in x!**

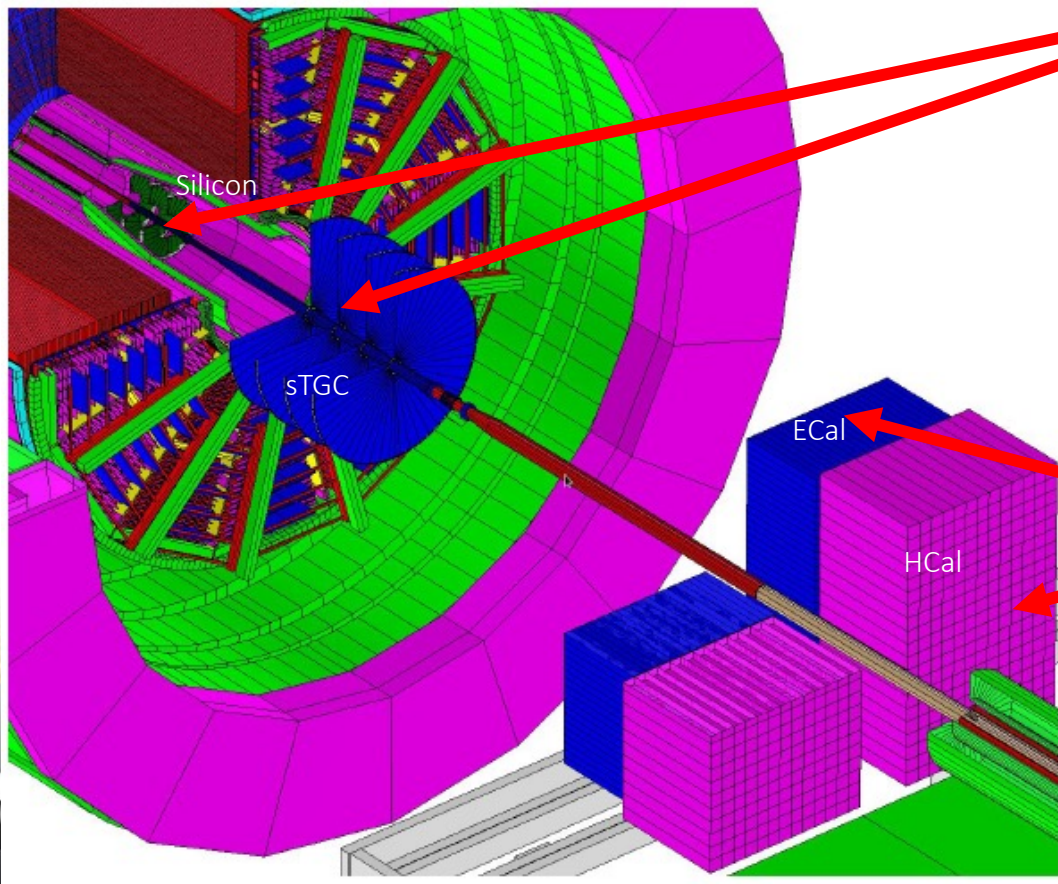

Forward Silicon Tracker (FST)

First data-taking run with these new components happened in 2022 – data being produced now!

Forward Calorimeter System (FCS)

# Looking Forward: The STAR Forward Upgrade

- Addition of silicon tracking system and EM and hadronic calorimetry → forward rapidity coverage.
  - More coverage in x!

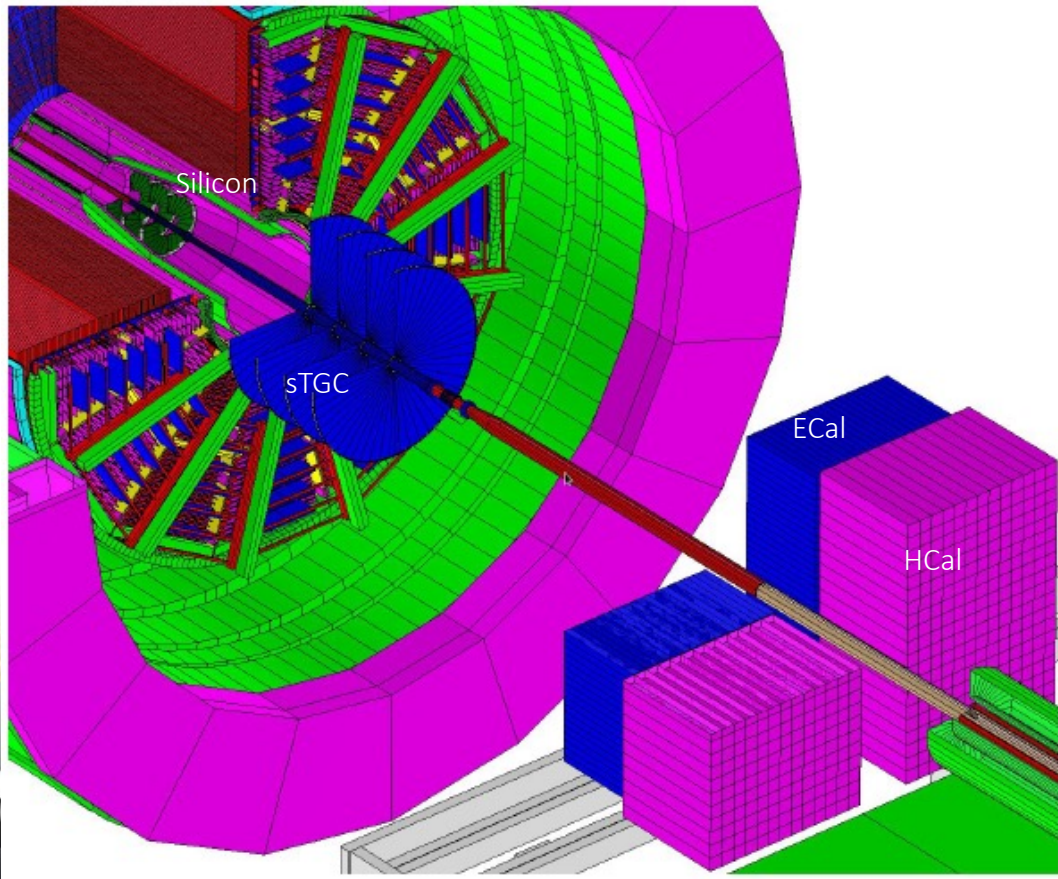

**Collecting Data Now!**

## • STAR Forward Upgrade

$$\text{Proton spin: } \frac{1}{2} = \frac{1}{2} \sum_q^{\text{quarks}} \Delta q + \Delta G + L_{g,q}^{\text{gluons}}$$

Orbital  
angular  
momentum

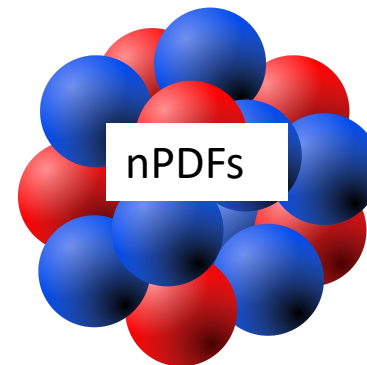

**Lots of overlap  
with EIC topics!**

# EIC Timeline

- Leverage STAR Cold QCD program and perform studies relevant to EIC physics.
- EIC detector and physics impact studies.

**2022-2025**

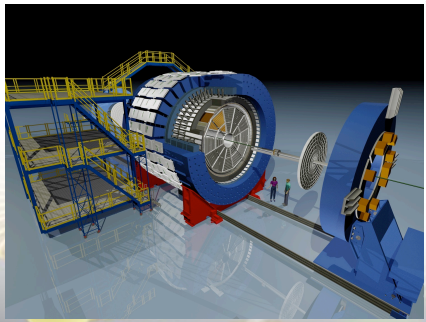

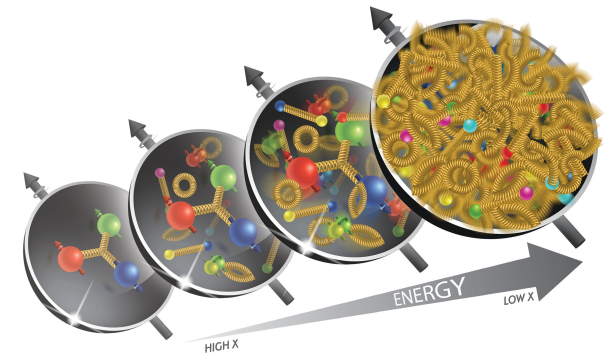
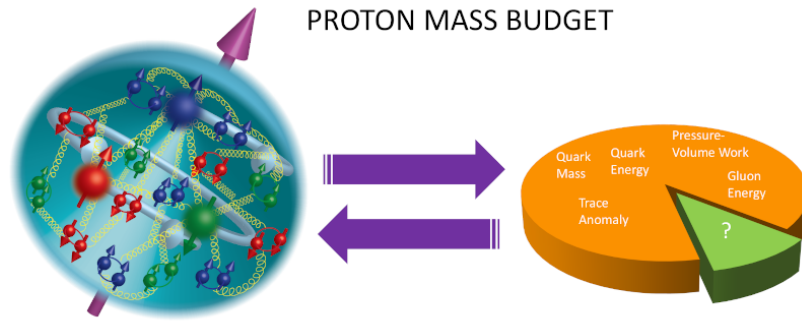
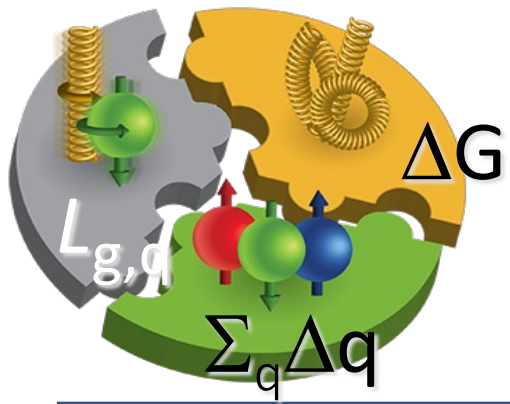

Our understanding of the structure of visible matter in the universe!

