

ePIC CC Meeting

-

Welcome

Thomas Ullrich

(BNL)

and

Bernd Surrw

(Temple University)

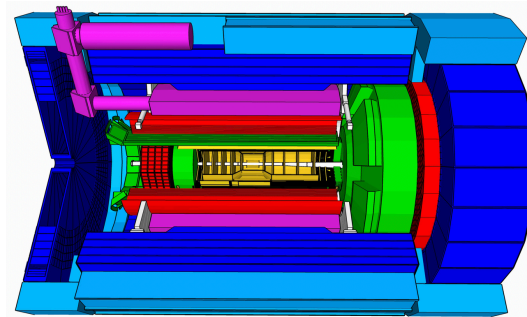

Outline

- Reminder of Meeting Conduct

- Proxy Representation for ePIC CC meeting

- Agenda Overview and Orientation

- Announcements

- Approval of Minutes - CC meeting July 27, 2024

Reminder of Meeting Conduct

- All ePIC collaborators are welcome to attend the ePIC Collaboration Council

(CC) Meeting, except for the closed session.

- Please keep your microphone muted if you are not speaking.
- We decided not to record the CC meetings some time ago, and I suggest we

proceed this way again.

Proxy Representation

- Known proxy representation in today's meeting:
 - Enrico Tassi (University of Calabria and INFN Cosenza) for Salvatore Fazio (University of Calabria and INFN Cosenza)
 - Simone Mazza (University of California, Santa Cruz) for Vitaliy Fadeyev (University of California, Santa Cruz)
 - Holly Szumila-Vance (Florida International University) for Joerg Reinhold (Florida International University)

Agenda Overview and Orientation

□ Overview

- We have a very packed agenda. **Please stay within your allocated time slot!**
- All speakers should present their material by sharing their screen unless you tell us otherwise. Please upload your slides to INDICO or let us know if you need help.
- Report from the SP Office
- Updates on the development of various ePIC policies
- Closed session:
 - Vote on Convener Endorsement
 - Upcoming Nominations / Elections
 - Institute Voting Suspension

ePIC Collaboration Council Meeting

Friday Nov 8, 2024, 10:30 AM → 2:00 PM US/Eastern

Description Connection Information (Password-protected): <https://temple.zoom.us/j/92329335429>
Minutes from the last ePIC CC meeting, July 27, 2024: [Click here!](#)

10:30 AM	→	10:40 AM	Welcome, Agenda, Approval of Minuits	⌚ 10m	✎
Speakers: Bernd Surrow (Temple University), Thomas Ullrich (BNL)					
ePIC_CC_Meeting...					
10:40 AM	→	10:50 AM	Report from the SP Office	⌚ 10m	✎
Speakers: John Lajoie (Oak Ridge National Laboratory), Silvia Dalla Torre (INFN, Trieste)					
Report from the SP ...					
10:50 AM	→	11:00 AM	Status Report - Ad-hoc Committee on Result Release Procedures	⌚ 10m	✎
Speaker: Rongrong Ma (Brookhaven National Laboratory)					
20241108_CC_Resu...					
11:00 AM	→	11:10 AM	Status Report - Publication Committee	⌚ 10m	✎
Speaker: Annalisa Mastroserio (Università degli Studi di Foggia and INFN)					
11:10 AM	→	11:20 AM	Status Report / Implementation - Conference and Talks Committee	⌚ 10m	✎
Speakers: Brian Page (Brookhaven National Laboratory), Maria Zurek (Argonne National Laboratory)					
11:20 AM	→	11:55 AM	Status Report and Discussion - Code of Conduct Committee	⌚ 35m	✎
Speaker: Megan Connors (Georgia State University)					
11:55 AM	→	12:25 PM	Status Report / Implementation - Membership Committee	⌚ 30m	✎
Speaker: Pietro Antonielli (INFN - sezione di Bologna)					
12:25 PM	→	1:25 PM	Closed Session		✎
<div style="background-color: #ccc; padding: 2px; margin-bottom: 5px;"> 12:25 PM Discussion and Vote: Procedure for Convener Endorsement ⌚ 15m ✎ </div> <div style="padding: 2px;"> Endorsement of convener candidates: Block or individual votes. We foresee a council vote on this internal procedural matter at the meeting through a simple majority vote. Speakers: Bernd Surrow (Temple University), Thomas Ullrich (BNL) </div>					
<div style="background-color: #ccc; padding: 2px; margin-bottom: 5px;"> 12:40 PM Upcoming Nominations / Elections ⌚ 15m ✎ </div> <div style="padding: 2px;"> The election committee will present plans and timelines for upcoming nominations/elections (Spokesperson / Vice Chair positions of policy committees) Speaker: Helen Caines (Yale) </div>					
<div style="background-color: #ccc; padding: 2px; margin-bottom: 5px;"> 12:55 PM Institute Voting Suspension ⌚ 15m ✎ </div> <div style="padding: 2px;"> Speakers: Bernd Surrow (Temple University), Thomas Ullrich (BNL) </div>					
<div style="background-color: #ccc; padding: 2px;"> 1:10 PM AOB ⌚ 15m ✎ </div>					

Announcements

- New Institutions: Two new institutions have been voted in favor of being admitted to join ePIC with a clear majority:
 - **Tohoku University**, Japan. Institutional Representative: Prof. Masashi Kaneta
 - **University of Petroleum and Energy Studies (UPES)**, India. Institutional Representative: Prof. Vipin Gaur Congratulations!

- Congratulations!

Announcements

- Endorsement for a list of seven new conveners listed below: The following conveners have been endorsed with an overwhelming majority:
 - Software & Computing:
 - **Stephen Kay (University of York)** --> User Learning WG Convener.
 - **Jeff Landgraf (BNL)** --> Third Streaming Computing WG Convener.
 - Physics:
 - **Rongrong Ma (BNL)** --> Jets+HF WG Convener.
 - **Juliette Mammei (University of Manitoba)** --> BSM + Precision EW WG Convener.
 - **Stephen Maple (University of Birmingham)** --> Inclusive Physics WG Convener.
 - **Ralf Seidl (RIKEN)** --> SIDIS WG Convener.
 - **Zhoudunming (Kong) Tu (BNL)** --> Exclusive+Diffraction+Tagging WG Convener.
- Congratulations!

Approval of Minutes

□ Agenda from CC meeting on July 26, 2024: <https://indico.bnl.gov/event/24307/>

□ Minutes:

Minutes from the ePIC Collaboration Council Meeting on July 26, 2024

Location: Lehigh University, Rauch Business Center, Bethlehem, PA
Mode: Hybrid
Agenda: <https://indico.bnl.gov/event/24307/>

Meeting was started by Council Chair Bernd Surrow welcoming all participants. The attendance was around 60 in person and 35 remotely via zoom. The chair explained the details of the agenda and announced plan for the formation of a Charter Update Committee. He also notified the collaboration that the final membership list collected by the previous chair, Ernst Sichtermann, will cause some changes in the number of Council representatives. Once this is completed the list will be stored in the new user DB (a.k.a. 'phonebook').

In a brief presentation Markus Diefenthaler (S&C Leader) presented the nomination for new S&C conveners. They are Stephen Kay for the User Learning WG and Jeff Landgraf for the Streaming Computing WG. Salvatore Fazio (co-analysis coordinator) introduced the candidates for the physics working groups. There are Ralf Seidl for the SIDIS WG, Rongrong Ma for the Jets and HF WG, Zhoujunming (Kong) Tu for the Exclusive WG, and Juliette Mammei for the BSM and Precision EW WG. The new convenue for the Inclusive WG was identified but cannot be confirmed yet. Salvatore thanked the outgoing conveners for their efforts.

Prof. Masashi Kaneta represented Tohoku University in Japan and presented the petition to join the collaboration providing some details on their planned contributions. Dr Vipin Gaur presented the petition by the University of Petroleum and Energy Studies (UPES) in India to join the collaboration. The consensus on both was to vote electronically on the admission(for/against/abstain).

The focus then changed on ePIC policies in preparation. Peter Steinberg talked about the status and the implementation of the Membership Policy which is currently being voted on for acceptance. Brian Page and Maria Zurek explained recent changes to the Conference and Talks Committee. A new draft will be submitted soon. They also informed the council of a decision made in a meeting between the chairs of the publication-, conference & talks committee and CC chairs to separate out the policy on the 'approval of preliminary and final results'. This policy will be formulated by an Ad-Hoc CC committee (to be formed) in the next weeks.

Rene Bellwied presented the status of the publication policy. No draft does exist yet.

Megan Connors discussed the current efforts of the DEI Committee to draft a Code-of-Conduct Policy. A new revised draft will be circulated after the meeting at Lehigh to the

collaboration at large with the request for input and comments. The DEI Committee also foresees to have BNL lawyers to read the policy and provide potential advice.

In the following discussion session it was decided that the votes on the petition by UPES and Tohoku University will be conducted together with the vote on the endorsement of the new conveners. It was agreed on, that the new conveners will be handled by a block vote not by individual votes. This decision is only applicable to the next voting cycle and does not set a precedence.