

ePIC CC Meeting

-

Welcome

Thomas Ullrich

(BNL)

and

Bernd Sorrow

(Temple University)

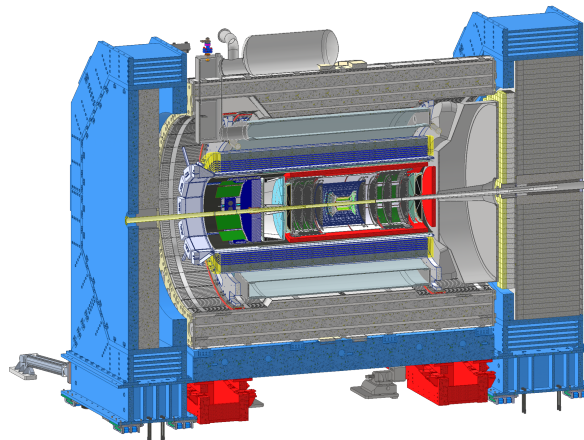

Outline

- Reminder of Meeting Conduct

- Proxy Representation for ePIC CC meeting

- Agenda Overview and Orientation

- Approval of Minutes - CC meeting November 8, 2024

- Announcements

Reminder of Meeting Conduct

- All ePIC collaborators are welcome to attend the ePIC Collaboration Council

(CC) Meeting, except for the closed session.

- Please keep your microphone muted if you are not speaking.
- We decided not to record the CC meetings some time ago, and I suggest we

proceed this way again.











Proxy Representation

- Known proxy representation in today's meeting:
 - Olga Evdokimov (University of Illinois, Chicago) for Austin Baty (University of Illinois, Chicago)
 - Simone Mazza (University of California, Santa Cruz) for Vitaliy Fadeyev (University of California, Santa Cruz)
 - Oleg Tsai (UCLA) for Huan Huang (UCLA)
 - Ernst Sichtermann (LBL) for Barbara Jacak (UC Berkeley)

Agenda Overview and Orientation

□ Overview

- We have a very packed agenda. **Please stay within your allocated time slot!**
- All speakers should present their material by sharing their screen unless you tell us otherwise. Please upload your slides to INDICO or let us know if you need help.
- Report from the SP Office
- Updates on the implementation and development of various ePIC policies
- Closed session
- We have to finish by 06:00 PM due to the strict bus schedule!

ePIC Collaboration Council Meeting			
Thursday Jan 23, 2025, 2:00 PM → 6:00 PM Europe/Rome			
Description ZOOM link: https://temple.zoom.us/j/95180856470?pwd=ZUISLyh2NYhU31q3YBZPN26etpIQX.1			
Minutes from the last ePIC CC meeting, November 8, 2024: Click here!			
2:00 PM	→ 2:15 PM	Welcome (10+5)	15m
		Speakers: Bernd Surrow (Temple University), Thomas Ullrich (BNL)	
			
2:15 PM	→ 2:30 PM	New Institution Presentation - Seoul National University (SNU) (10+5)	15m
		Speaker: Inseok Yoon (Seoul National University)	
			
2:30 PM	→ 2:35 PM	Election Committee Statement	5m
		Speaker: Helen Caines (Yale)	
			
2:35 PM	→ 3:05 PM	Spokesperson Next Term Vision Presentation (20+10)	30m
		Speakers: John Lajole (Oak Ridge National Laboratory), Silvia Dalla Torre (INFN, Trieste)	
			
3:05 PM	→ 3:35 PM	Common Funds (20+10)	30m
		Speaker: John Lajole (Oak Ridge National Laboratory)	
		 	
3:35 PM	→ 4:00 PM	Status Update: Result Release Committee (15+10)	25m
		Speaker: Rongrong Ma (Brookhaven National Laboratory)	
		 	
4:00 PM	→ 4:15 PM	Coffee Break	15m
4:15 PM	→ 4:30 PM	Publication Policy Status (15)	15m
		Speakers: Annalisa Mastroserio (Università degli Studi di Foggia and INFN), Rene Bellwied (University of Houston)	
			
4:30 PM	→ 5:00 PM	Publication Policy Discussion (30)	30m
		Speakers: Annalisa Mastroserio (Università degli Studi di Foggia and INFN), Rene Bellwied (University of Houston)	
			
5:00 PM	→ 5:30 PM	Update Membership Committee (15+15)	30m
		Speaker: Pietro Antonioli (INFN - sezione di Bologna)	
			
5:30 PM	→ 5:33 PM	Remarks from the Conferences and Talks Committee	3m
		Speaker: Maria Zurek (Argonne National Laboratory)	
5:35 PM	→ 5:50 PM	Closed Session	15m
		Speakers: Bernd Surrow (Temple University), Thomas Ullrich (BNL)	

Approval of Minutes

- Agenda from CC meeting on November 8, 2024: <https://indico.bnl.gov/event/24841/>

Minutes from the ePIC Collaboration Council Meeting on November 8, 2024

- Minutes:

Location: Remote CC Meeting

Mode: Remote

Agenda: <https://indico.bnl.gov/event/24841/>

The meeting was started by Council Chair Bernd Surrow, welcoming all participants. Around 80 participants were attending via Zoom. The chair reviewed the details of the agenda.

John Lajoie provided a report from the spokesperson, including welcoming newly admitted institutions and newly appointed conveners. An overview of past and upcoming reviews and meetings was provided, including an overview of the agenda structure for the January 2025 collaboration meeting in Frascati, Italy. A summary of the TDR and publication strategy was provided. An overview of future collaboration meetings was given, reminding the collaboration for open calls of the 2025/2026 summer joint meetings and the January 2026 ePIC meeting. John emphasized that documents have been signed to establish ePIC as a CERN-recognized experiment.

Status reports were provided by Rongrong Ma on behalf of the “Ad-hoc Committee on Result Release Procedures”, by Annalisa Mastroserio on the “Publication Committee” work toward a draft document, by Brian Page on the Conference and Talks Committee work, and by Megan Connors on the “Code of Conduct Policy, along with the anticipated timeline for adopting the respective policy. Pietro Antonioli discussed plans for the implementation of the Membership policy.

During a closed session, a vote was called to decide on the procedure for convener endorsement. The vote during the meeting favored an individual voting procedure rather than a block voting. Helen Caines presented plans for the upcoming nomination/election process for the spokesperson, CC vice-chair, and vice-chair positions of various policy committees. The last item was devoted to executing the charter for voting suspension of institutions that have not participated in multiple elections.

Announcements

- Transition of Vice-Chair / Chair appointment for CC committees
 - With the **completion of various policies**, we decided not to disturb the process, asking several chairs to continue until the policies were in place.
 - We want to express our sincere thanks to those who helped with this!
 - We will deal with the **appointment of new vice-chairs during the next couple of weeks (Nomination/Election)**. Thank you!

- Update of charter
 - We are also in conversation about forming an **ad-hoc committee to help with updating the charter** over the next couple of months considering that several aspects would benefit from refinements!