

COSENZA

UNIVERSITÀ DELLA CALABRIA

Simulation of Aerogel for the dRICH detector

Luisa Occhiuto*,

Annalisa De Caro, Salvatore Fazio

On behalf of the ePIC dRICH simulation team



ePIC and EIC Physics Readiness Workshop, Cosenza 17-19 March
2026

Outline

- Particle ID and the dRICH detector
- Performance simulation studies (Phase I)
 - Aerogel laboratory characterization
- Performance simulation studies (Phase II)
- Geometry optimization
- Multiplicity studies

Particle ID: a key challenge

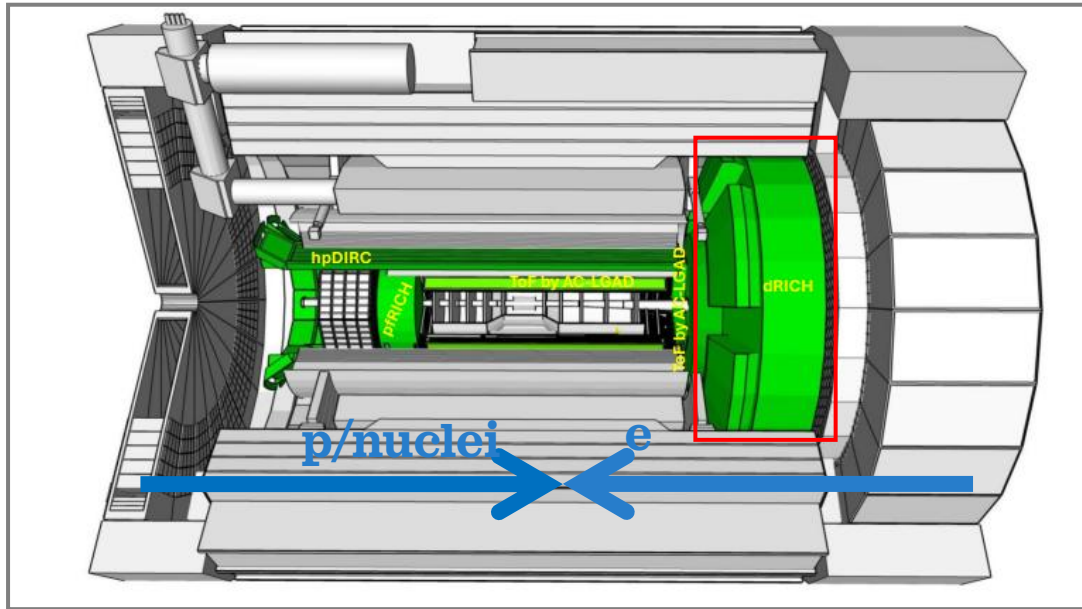

π/K separation requirements:

Backward → pfRICH

- Up to 9 GeV/c

Central → hpDIRC + ToF

- Up to 6 GeV/c

Forward → dRICH + ToF

- Up to 50 GeV/c

Key Detector Requirement:

- ✓ Essential for identifying particles from **e+p/nuclei collisions**
- ✓ Compact design with high performance in the **forward region**
- ✓ Critical for physics goals: **e/ π separation up to 50 GeV/c**

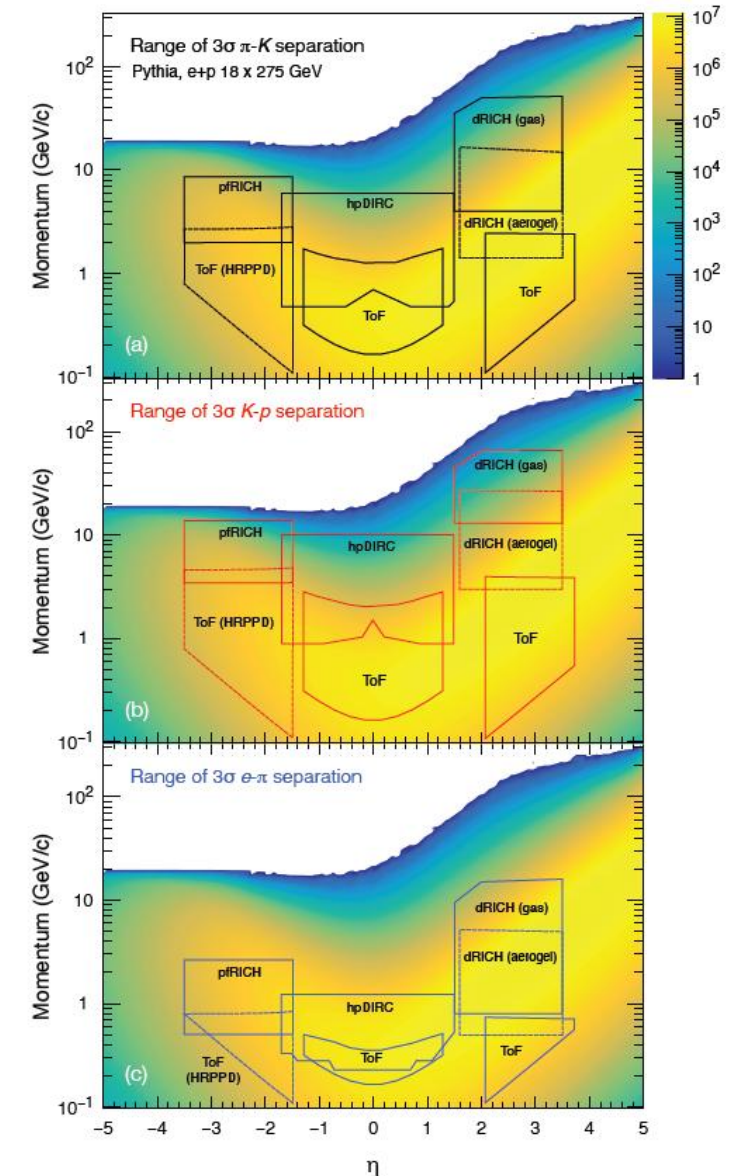

The dRICH detector

Radiators:

- Aerogel ($n \sim 1.026$): changed from baseline $n \sim 1.019$
- C_2F_6 ($n \sim 1.0008$)

Mirrors

- Large outward-reflecting, 6 open sectors

Sensors

- Single-photon detection
- High photon detection efficiency
- Insensitive to the magnetic field
- SiPM as a cost effective solution

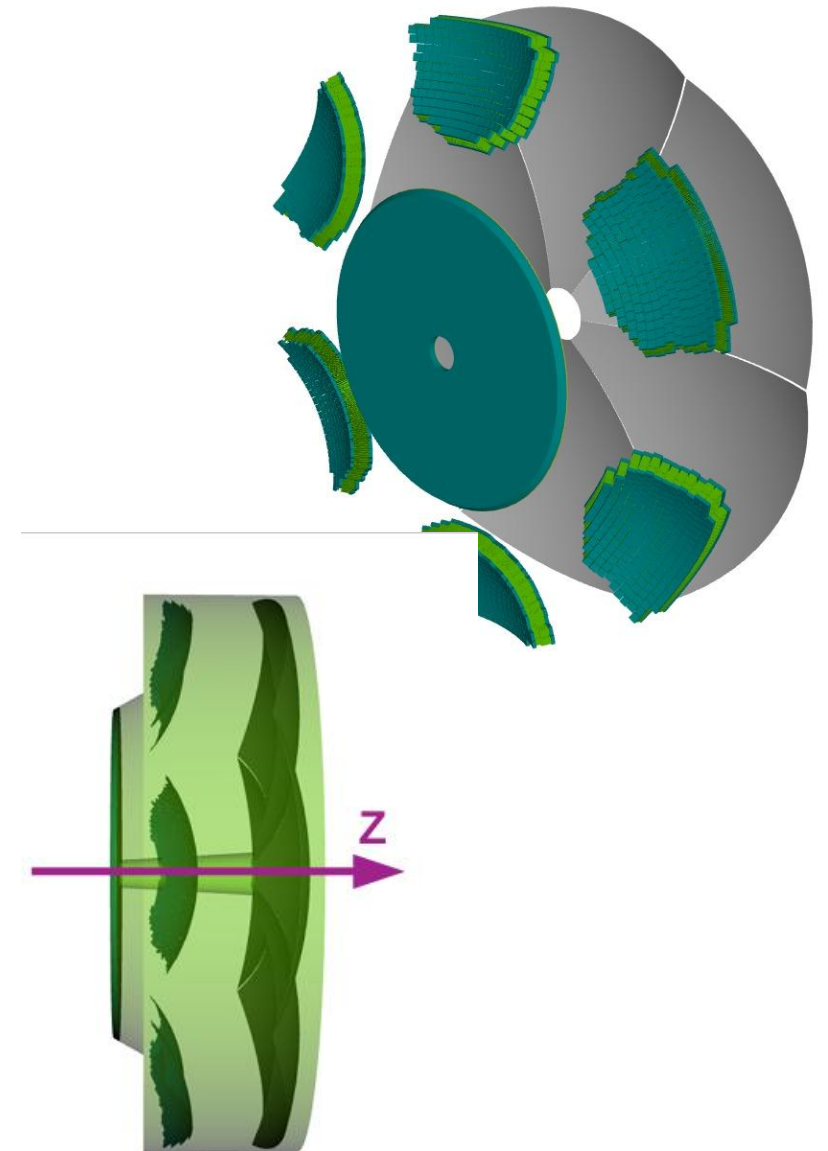

Requirements for radiators

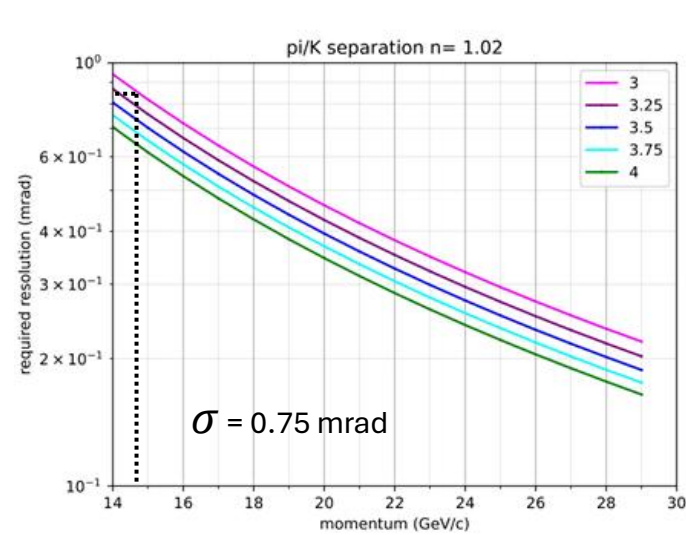

Nominal ($n \sim 1.019$)

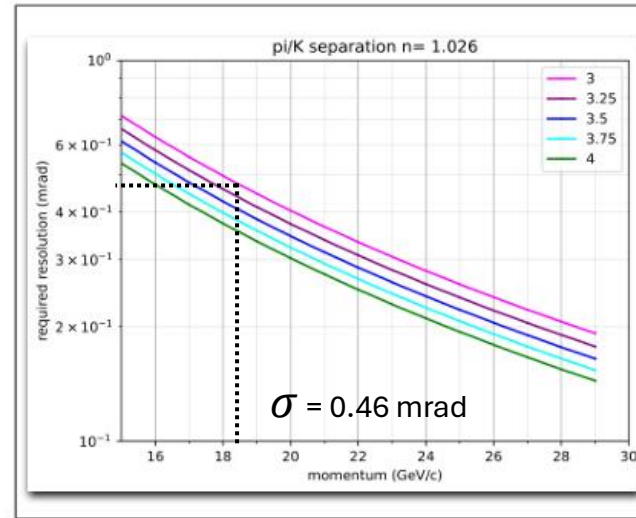

Type-1 ($n \sim 1.026$)

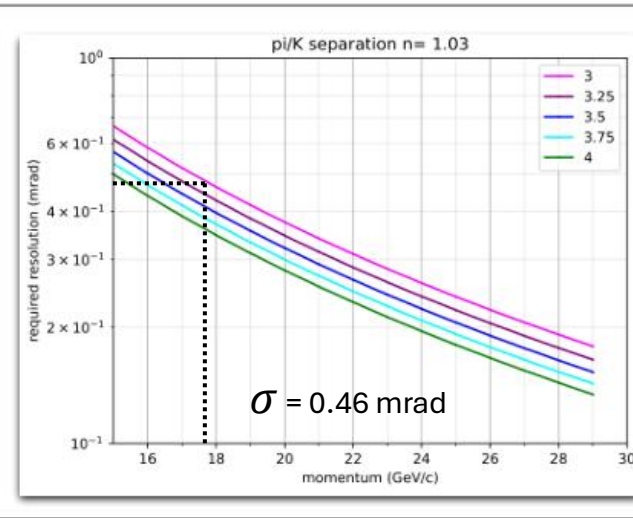

Type-2 ($n \sim 1.03$)

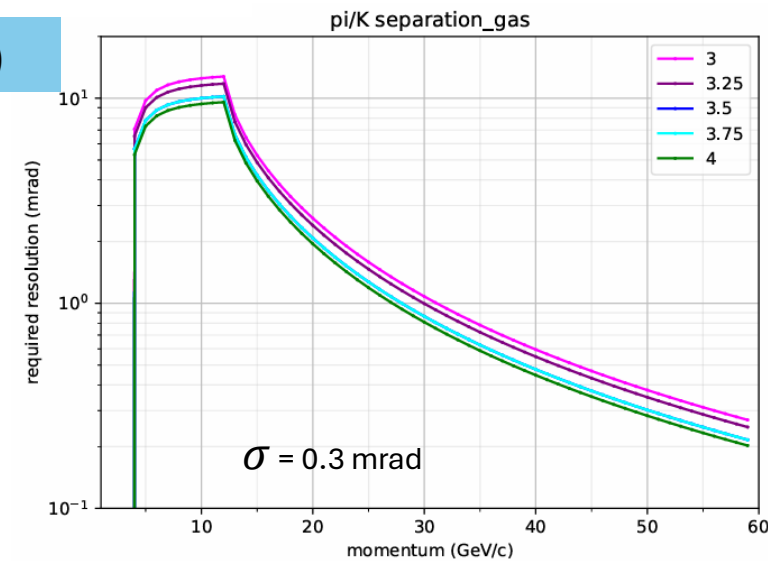

- ✓ In order to achieve at least a 3σ pion/Kaon separation up to 15 GeV/c in Aerogel we need a ring resolution better than 0.75 mrad with nominal refractive index $n=1.019$.
- ✓ In order to achieve at least a 3σ pion/Kaon separation above 50 GeV/c we need a *ring resolution* ($\frac{\sigma_{PE}}{\sqrt{NPE}}$) around 0.3 mrad.

Simulation results for Gas and Nominal Aerogel (n=1.019)

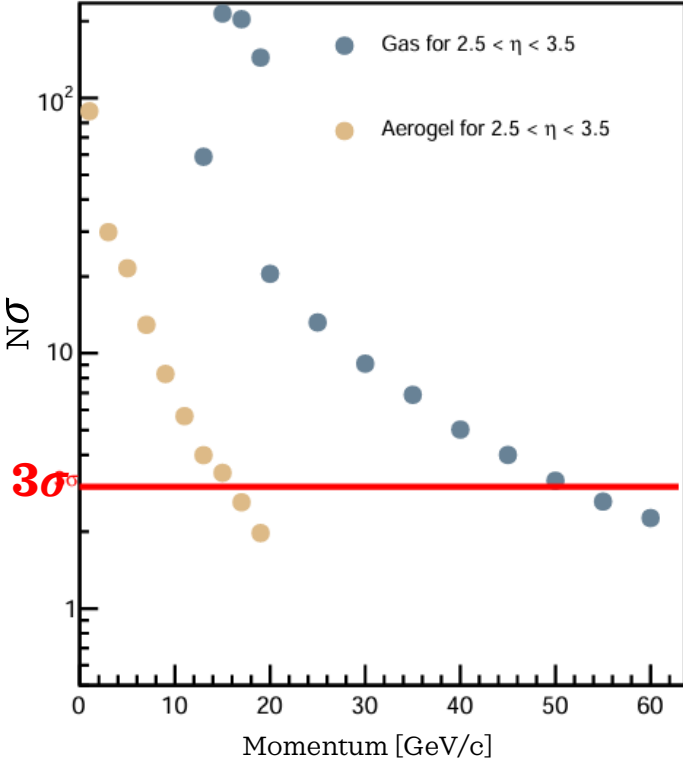
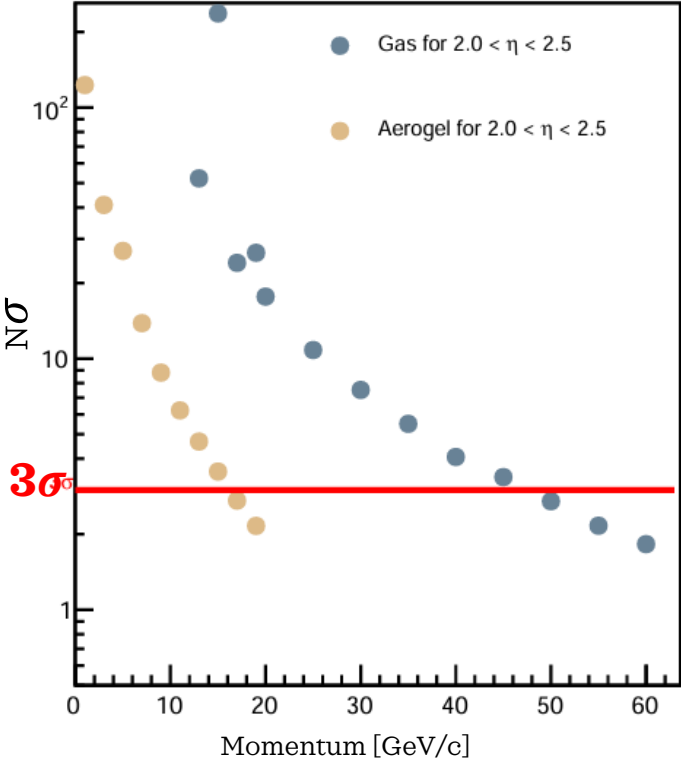
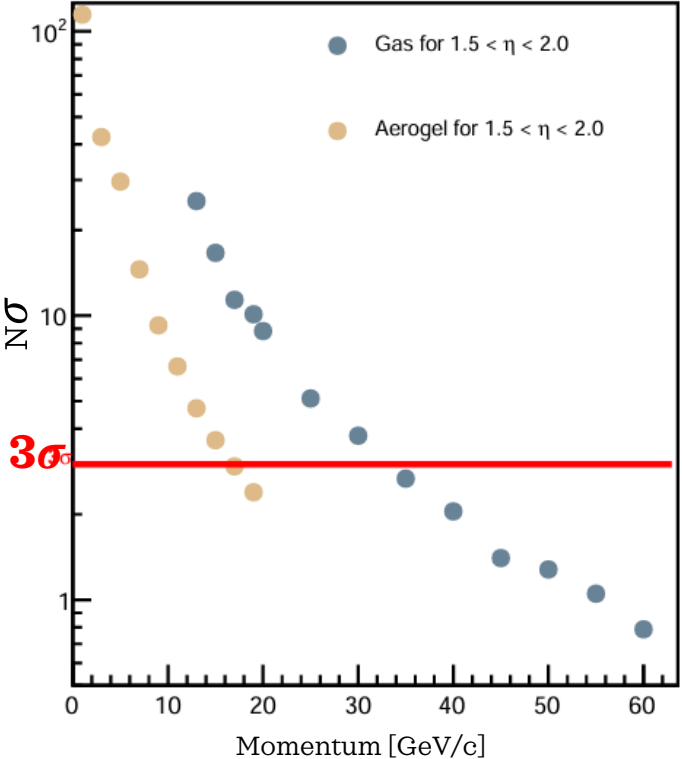

@ $\eta > 2.5$ we achieve 3σ with ~ 15 GeV/c of momentum for the aerogel and ~ 50 GeV/c for the gas.

No discontinuity in PID

Simulation results for Gas and Nominal Aerogel (n=1.019)

GAS

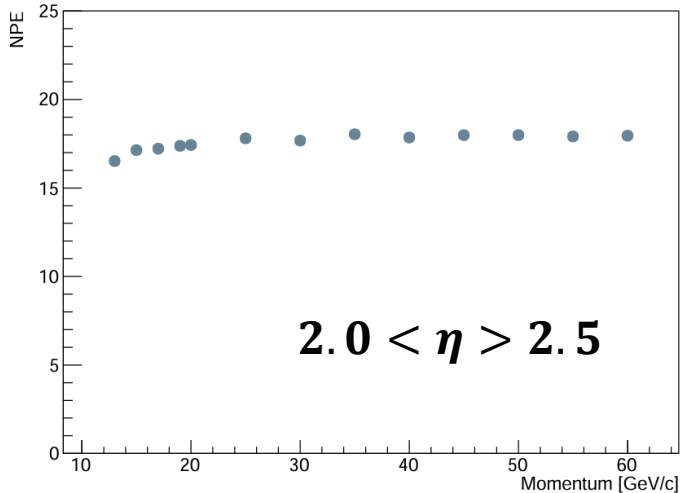
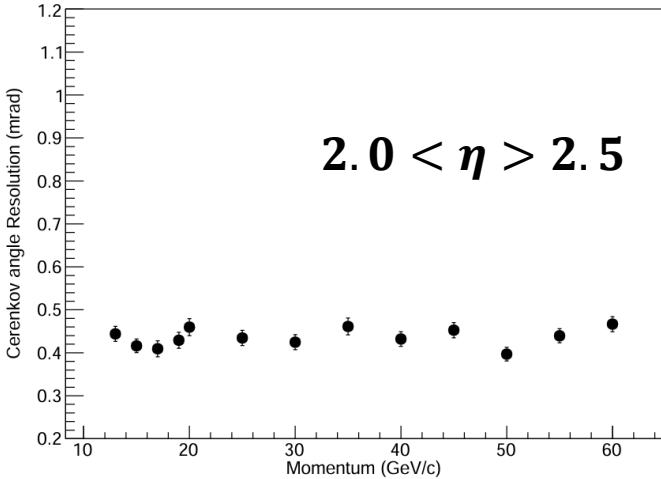

Aerogel

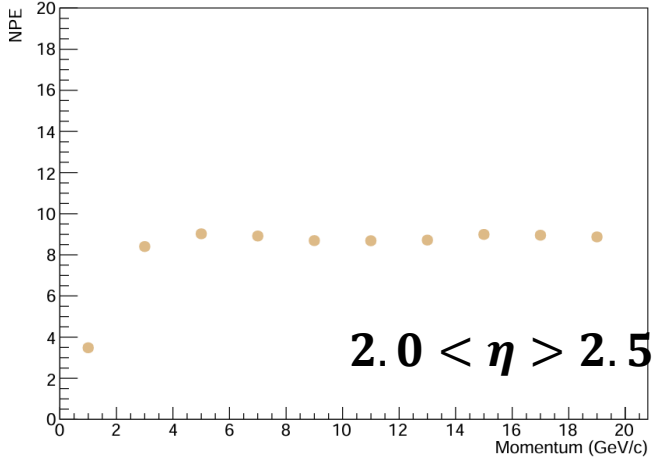
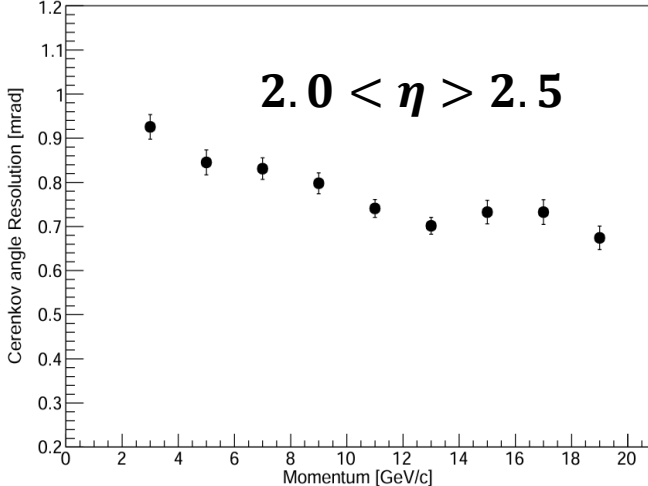

Cherenkov angle resolution compatible with the expectations

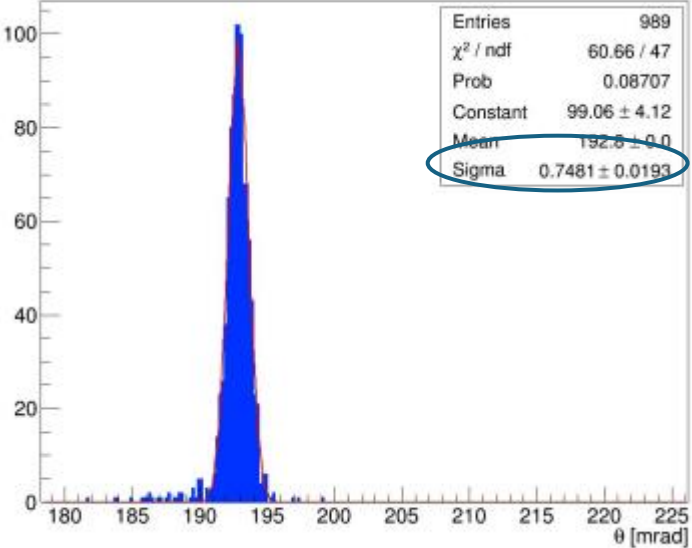

Potential issues:
 Availability
 Hydrophobic aerogel available from Chiba Aerogel Factory Japan.
 Better optical quality.

Aerogel characterization @ INFN Bari (A. Altamura et al)

Measurements performed with a Perkin Elmer spectrometer at CERN, using an integrating sphere and a light source to cover the range 250- 800 nm to map the Linear Transmittance.

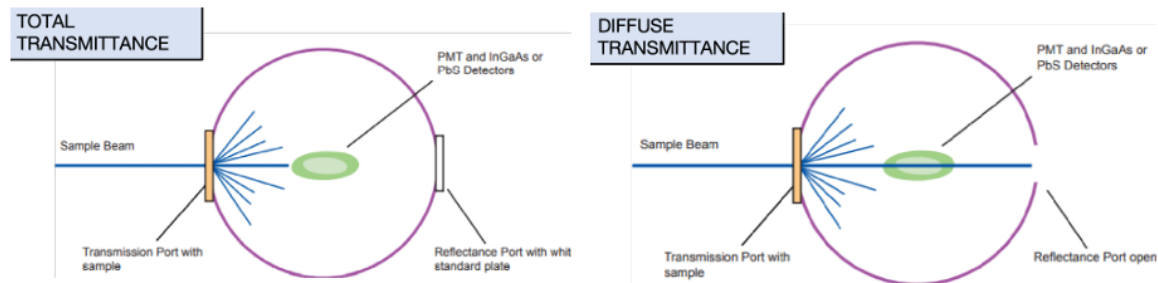

LINEAR TRANSMITTANCE

$$T_{LIN} = T_{TOT} - T_{DIFF}$$

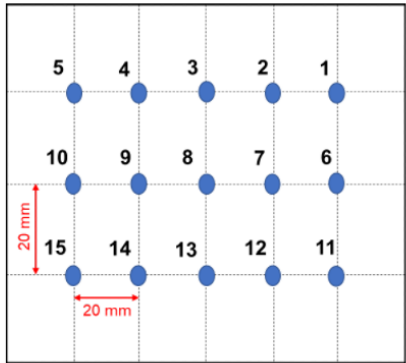

The transmittance is not uniform: thinner areas transmit light better. Non-planarity (up to 1.27 mm) can distort the Cherenkov angle reconstruction.

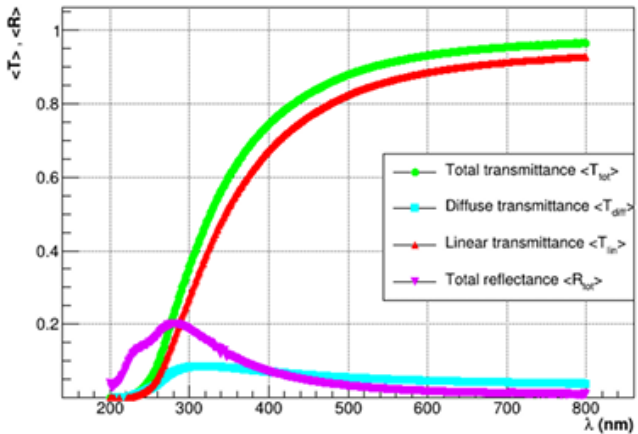
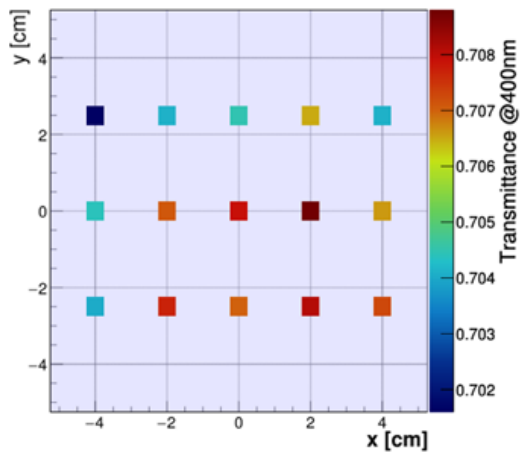
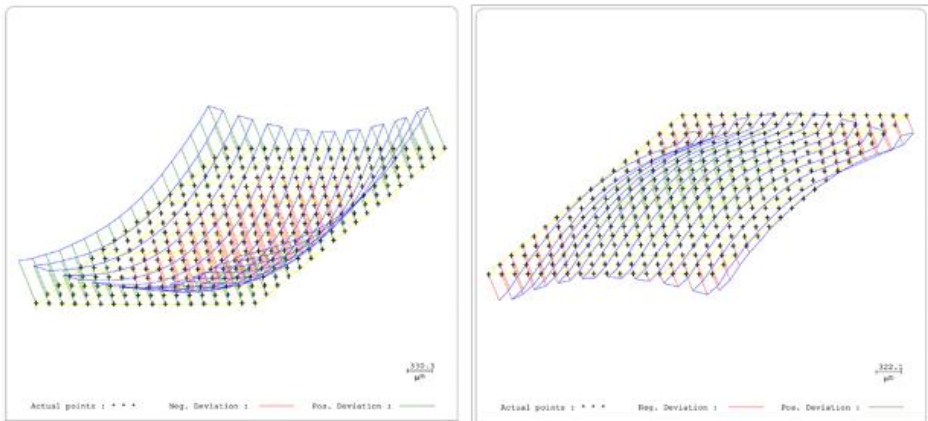

For more details
 look at
<https://pos.sissa.it/476/1116/>

Aerogel characterization @ INFN Bari (A. Altamura et al)

2-parameters **Hunt-basic formula**

$$T(\lambda) = e^{-\frac{t}{\Lambda_{trasm}}} = Ae^{-\frac{Ct}{\lambda^4}}$$

ASSUMPTIONS

Λ_A constant

$\Lambda_S \sim \lambda^4$

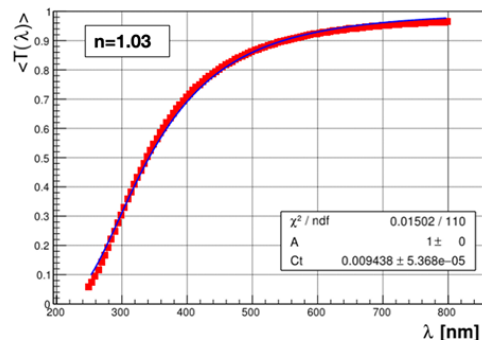

3-parameters **Hunt-extended formula**

$$T(\lambda) = e^{-\frac{t}{\Lambda_{trasm}}} = Ae^{-\frac{Bt}{\lambda^8}} e^{-\frac{Ct}{\lambda^4}}$$

ASSUMPTIONS[3]

$\Lambda_A \sim \lambda^8$

$\Lambda_S \sim \lambda^4$

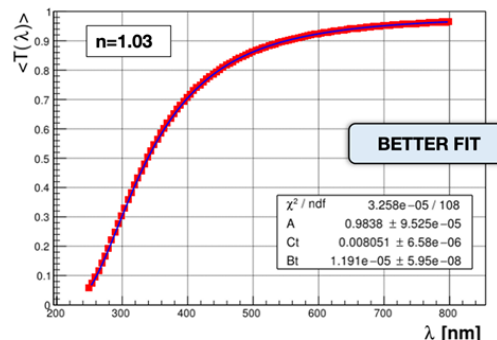

For more details
look at
<https://pos.sissa.it/476/1116/>

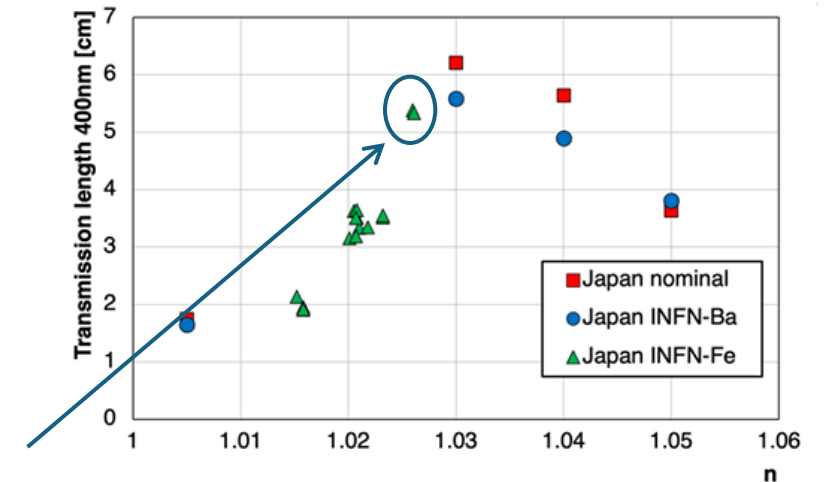
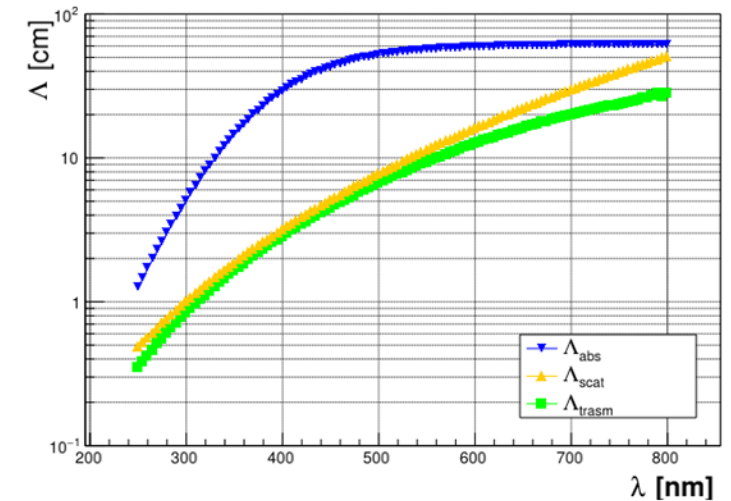

- ✓ Adding a third parameter λ^8 allows for better modeling of the absorption, resulting in higher statistical precision.
- ✓ Absorption negligible; the loss of transparency was dominated almost entirely by Rayleigh scattering.
- ✓ **$n=1.026$: the best compromise between optical performance and spatial constraints.**

Simulation result for new Aerogel

n=1.019 vs n=1.026

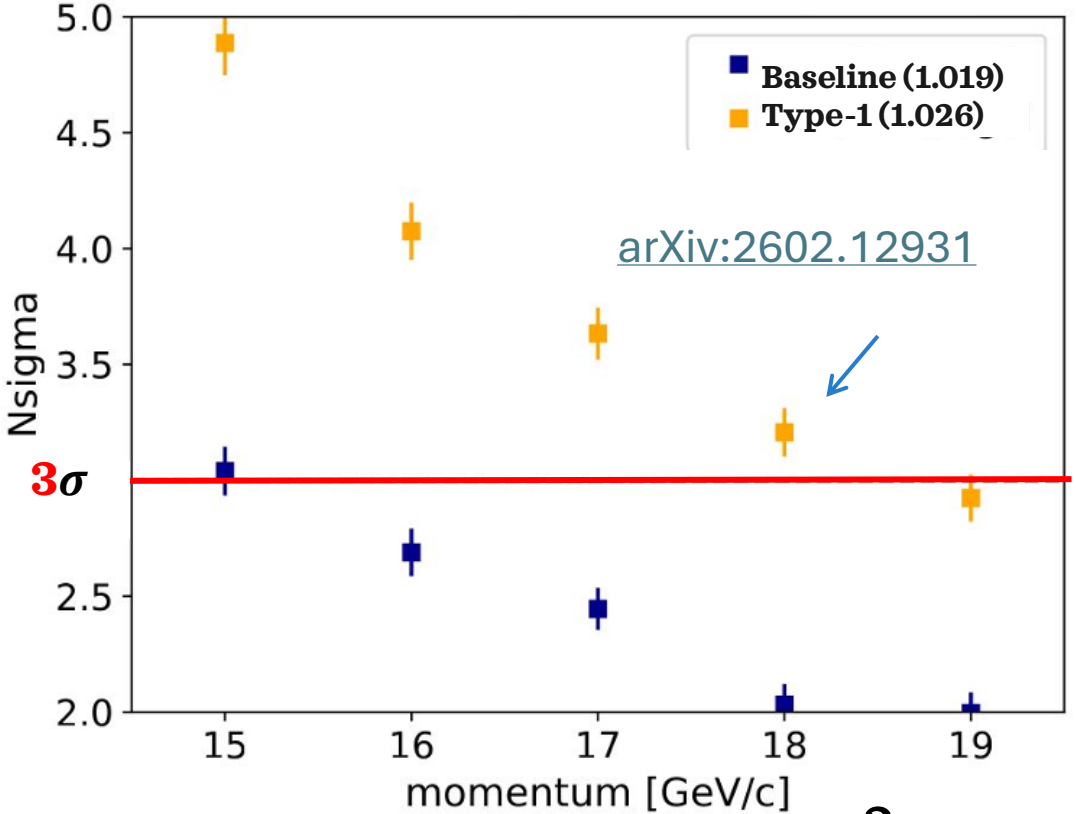

n=1.03

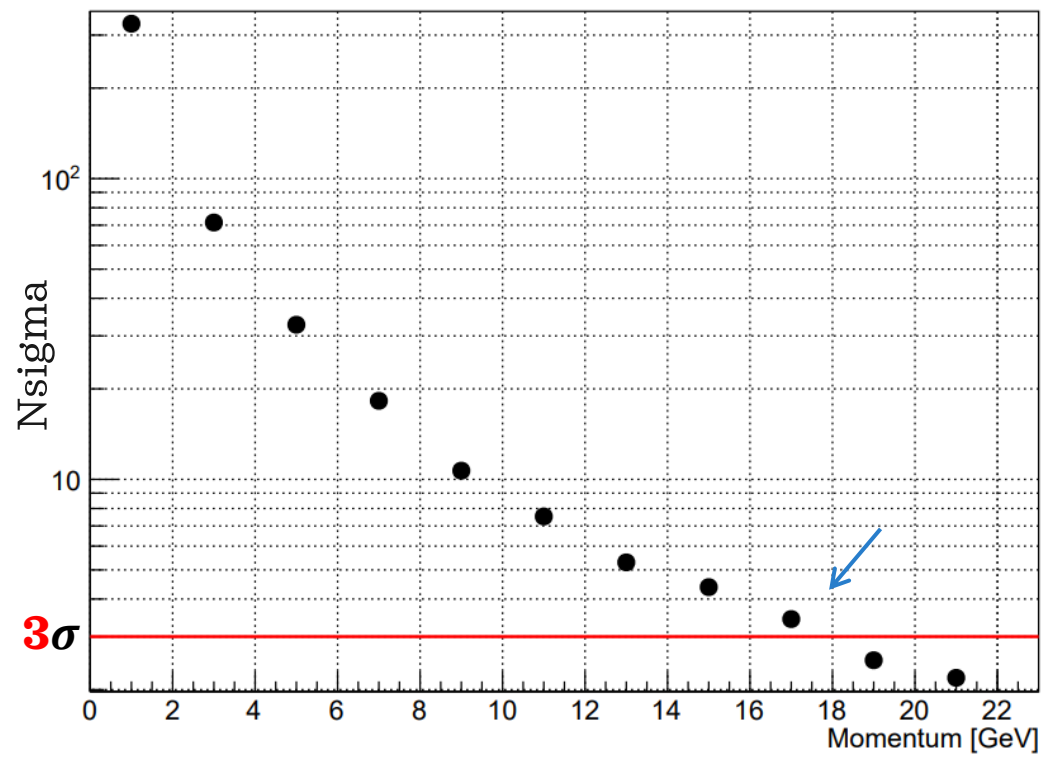

3σ separation at ~ 17/18 GeV/c of momentum!

Simulation results for new Aerogel

n=1.019 vs n=1.026

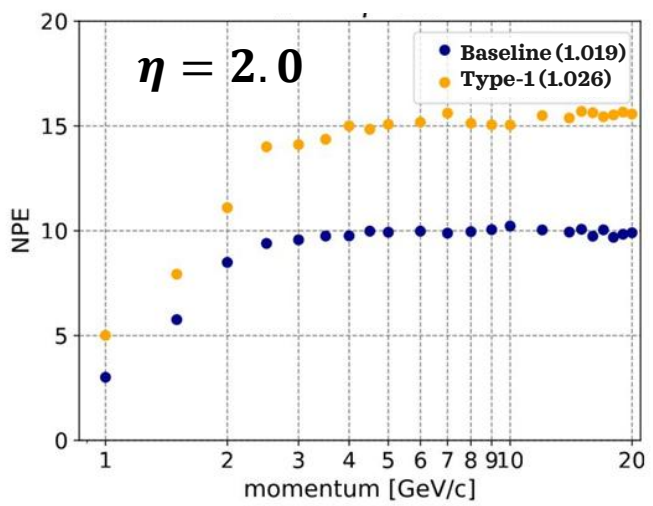

n=1.03

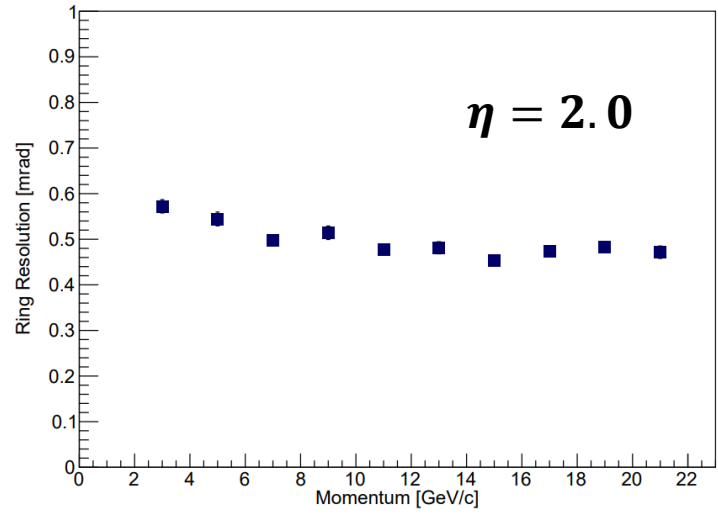
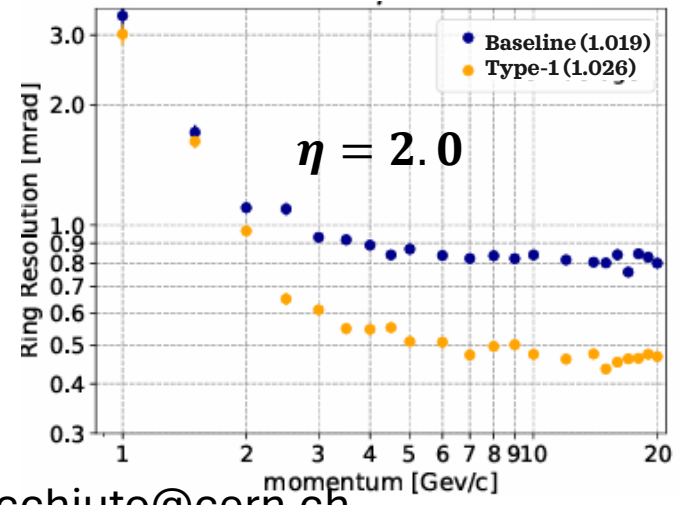
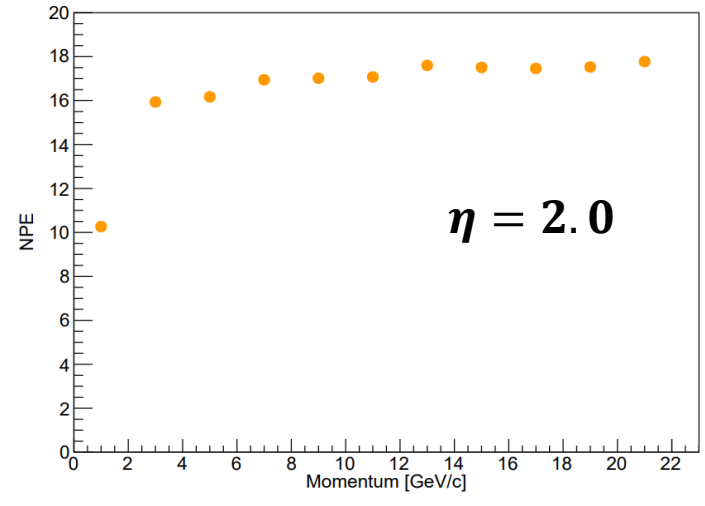

Also the NPE increase (~50%) and the Cherenkov angle resolution improves (>30%)!

Chromatic aberration

<https://zenodo.org/records/14328280>

What is Chromatic aberration?

- ✓ Optical effect limiting the **precision of Cherenkov angle measurements**
- ✓ Caused by **wavelength-dependent refractive index** (of aerogel or gas)

How is its impact estimated?

Simulation with and without λ – **dependence** of refractive index

- ✓ 1000 events.
- ✓ PID: 211
- ✓ Momentum fixed @ 15 GeV/c.
- ✓ Different bins of η .

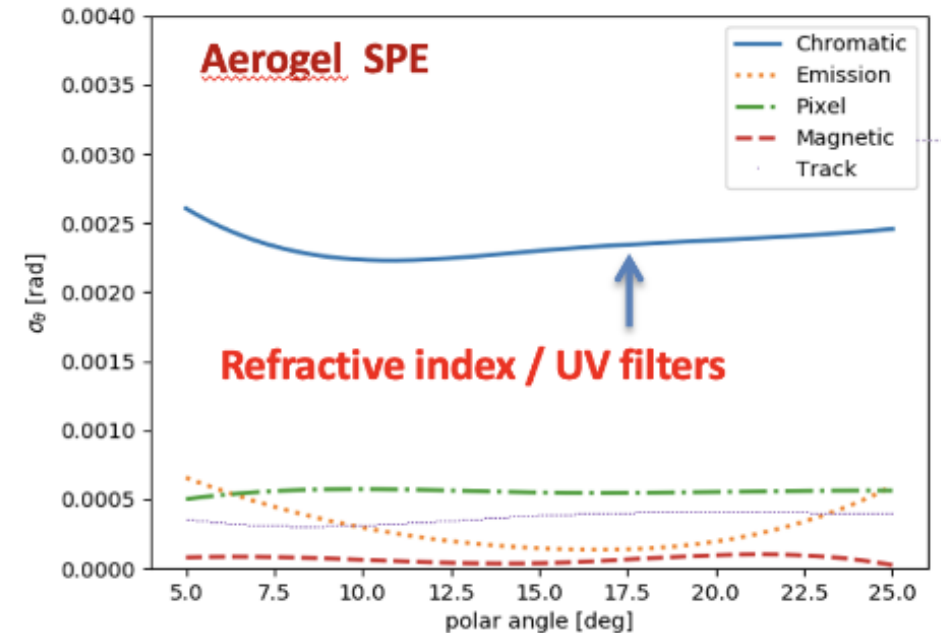

Chromatic term dominates the angular uncertainty!

Studied at two refractive index values!

Chromatic aberration in Aerogel

n=1.019

Chromatic aberration as a function of η , fixing momentum @ 15 GeV/c.

$$\sigma_{\{chromatic\ aberration\}} = \sqrt{\sigma_{tot}^2 - \sigma_{w/o\ \lambda\ dep.}^2}$$

Where σ_{tot}^2 is σ with λ dependency and $\sigma_{w/o\ \lambda\ dep.}^2$ is σ with n fixed (w/o λ dependency).

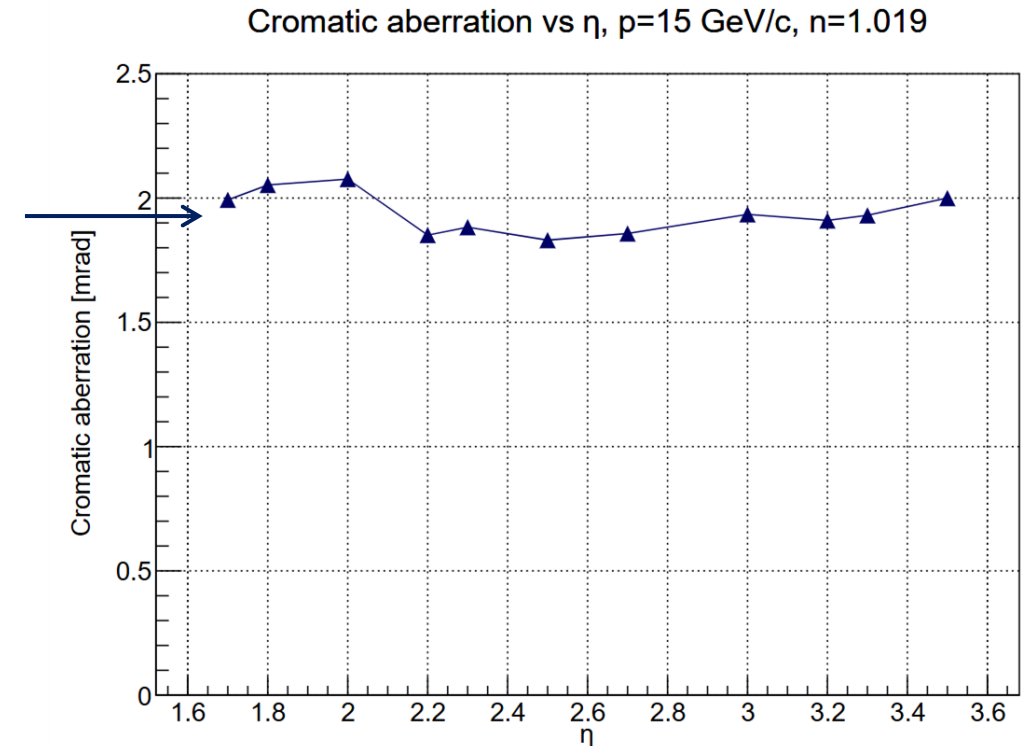

Chromatic aberration in Aerogel

n=1.026

Chromatic aberration as a function of η , fixing momentum @ 15 GeV/c.

$$\sigma_{\{chromatic\ aberration\}} = \sqrt{\sigma_{tot}^2 - \sigma_{w/o\ \lambda\ dep.}^2}$$

Where σ_{tot}^2 is σ with λ dependency and $\sigma_{w/o\ \lambda\ dep.}^2$ is σ with n fixed (w/o λ dependency).

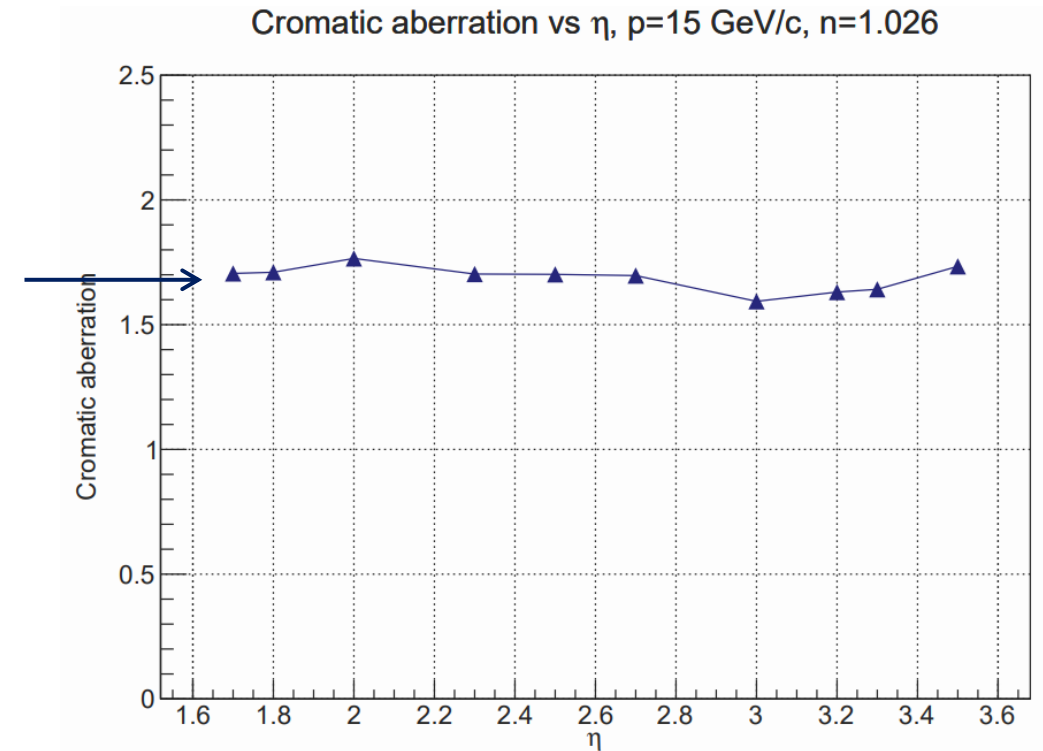

Aerogel validation @ CUK (J.Agarwala et al.)

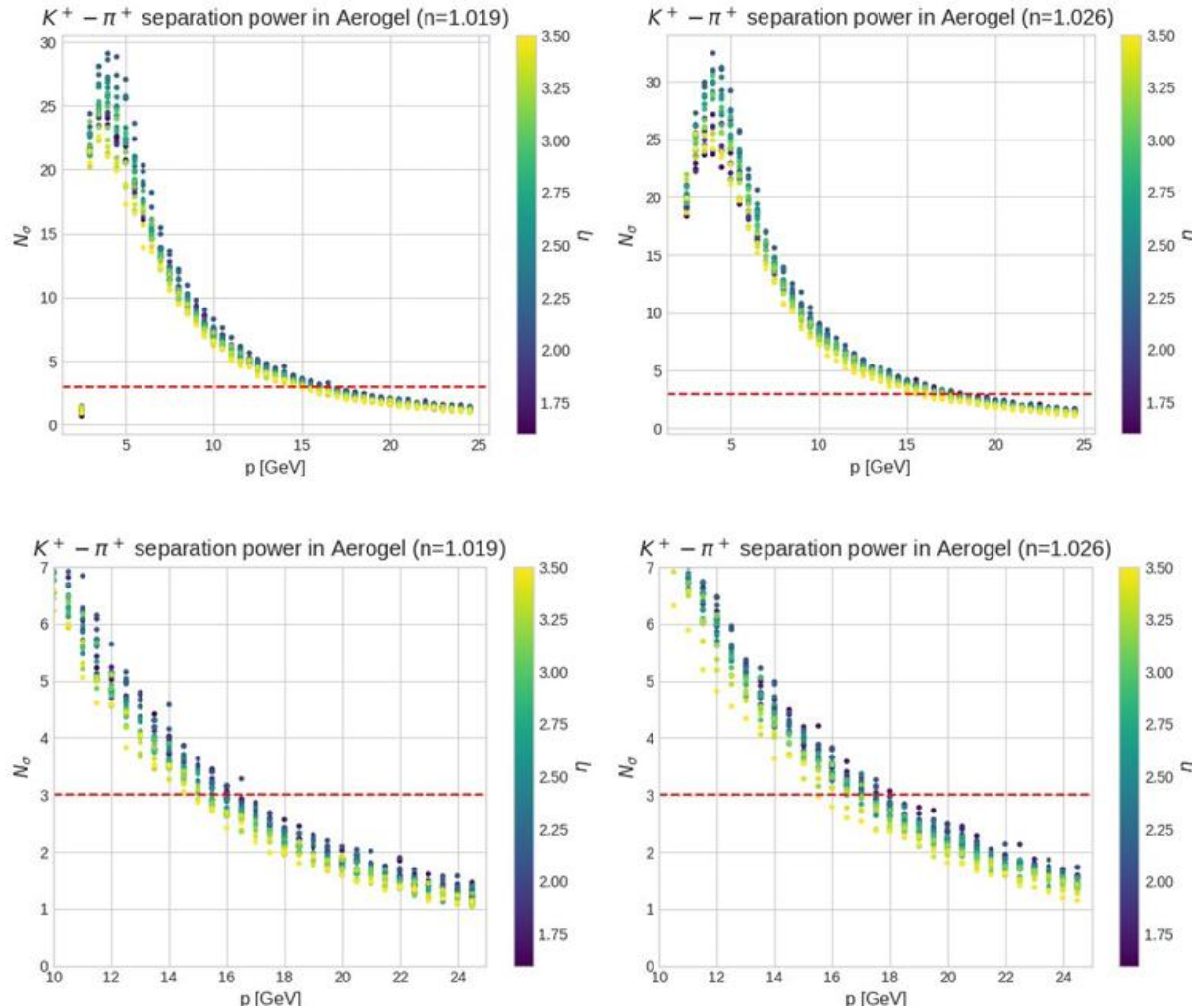

- ✓ **Infrastructure:** GPU facility at Central University of Karnataka (CUK) for dRICH parallel processing.
- ✓ **Fine Granularity:** 74 momentum bins (0.5-60 GeV/c) and 0.1 η steps.
- ✓ **Efficiency:** Large-scale simulations completed in 5 days (using 25 GPU cores)
- ✓ **Significant Nsigma boost with $n=1.026$ and π/K separation up to 20 GeV/c**

For more details look @ https://doi.org/10.1007/978-981-95-1513-4_352

Geometry evolution: From mechanics to simulation

From mechanics

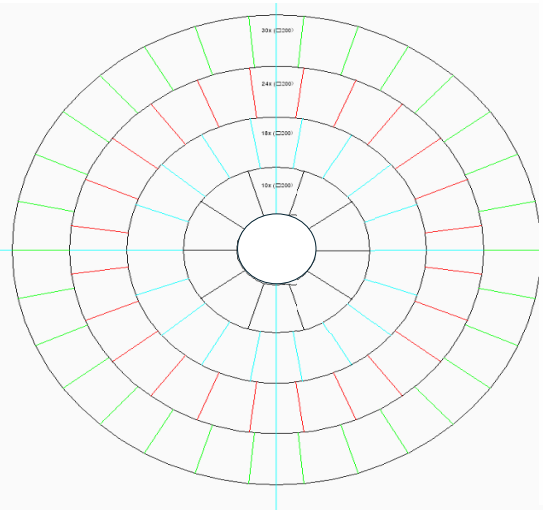

Option A

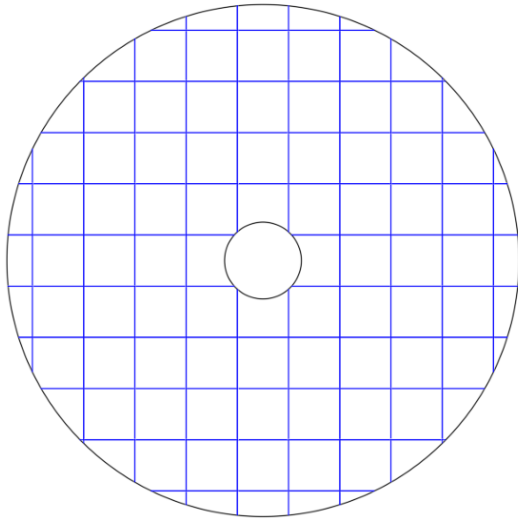

Option B

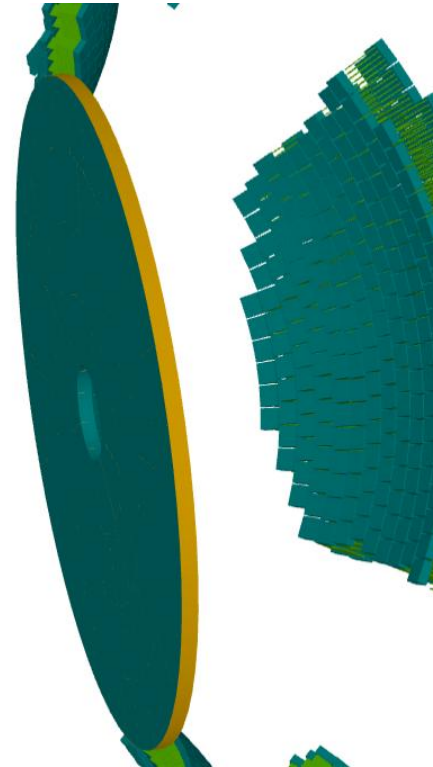

+

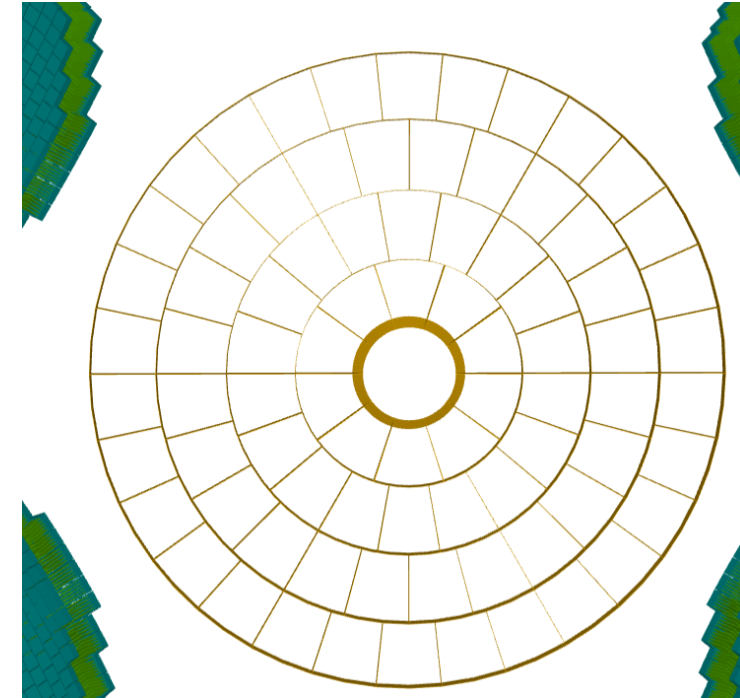

- ✓ From conical aerogel to cylindrical aerogel.
- ✓ Carbon fiber support structure added.
- ✓ Crowns and segments implemented as easily editable parameters via xml file.

Acceptance performance

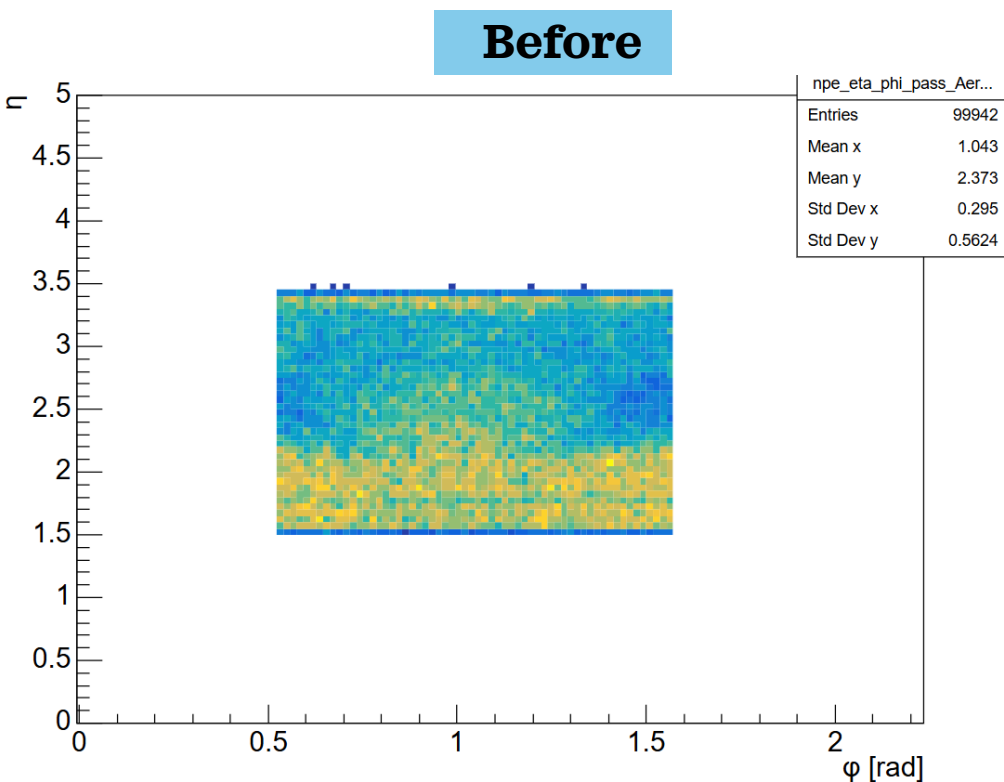

- ✓ 200k events.
- ✓ $n = 1.019$
- ✓ Particles 10 GeV/c momentum
- ✓ **$N_{pe} > 5$**
- ✓ $\phi \in [\pi/6, \pi/2]$
- ✓ $\eta \in [1.5, 3.5]$

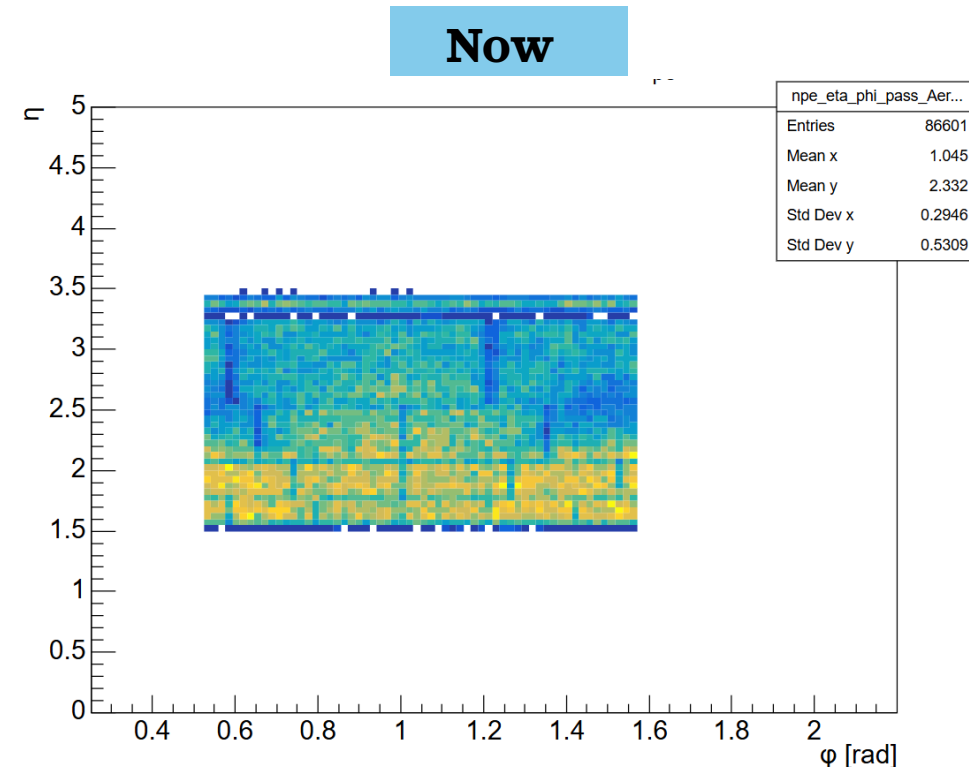

- ✓ 200k events.
- ✓ $n = 1.019$
- ✓ Particles 10 GeV/c momentum
- ✓ **$N_{pe} > 5$**
- ✓ $\phi \in [\pi/6, \pi/2]$
- ✓ $\eta \in [1.5, 3.5]$

Acceptance performance

Looking into more details....

- ✓ 200k events.
- ✓ $n = 1.019$
- ✓ Particles 10 GeV/c momentum
- ✓ **$N_{pe} > 5$**
- ✓ $\phi \in [\pi/6, \pi/2]$
- ✓ $\eta \in [1.5, 3.5]$

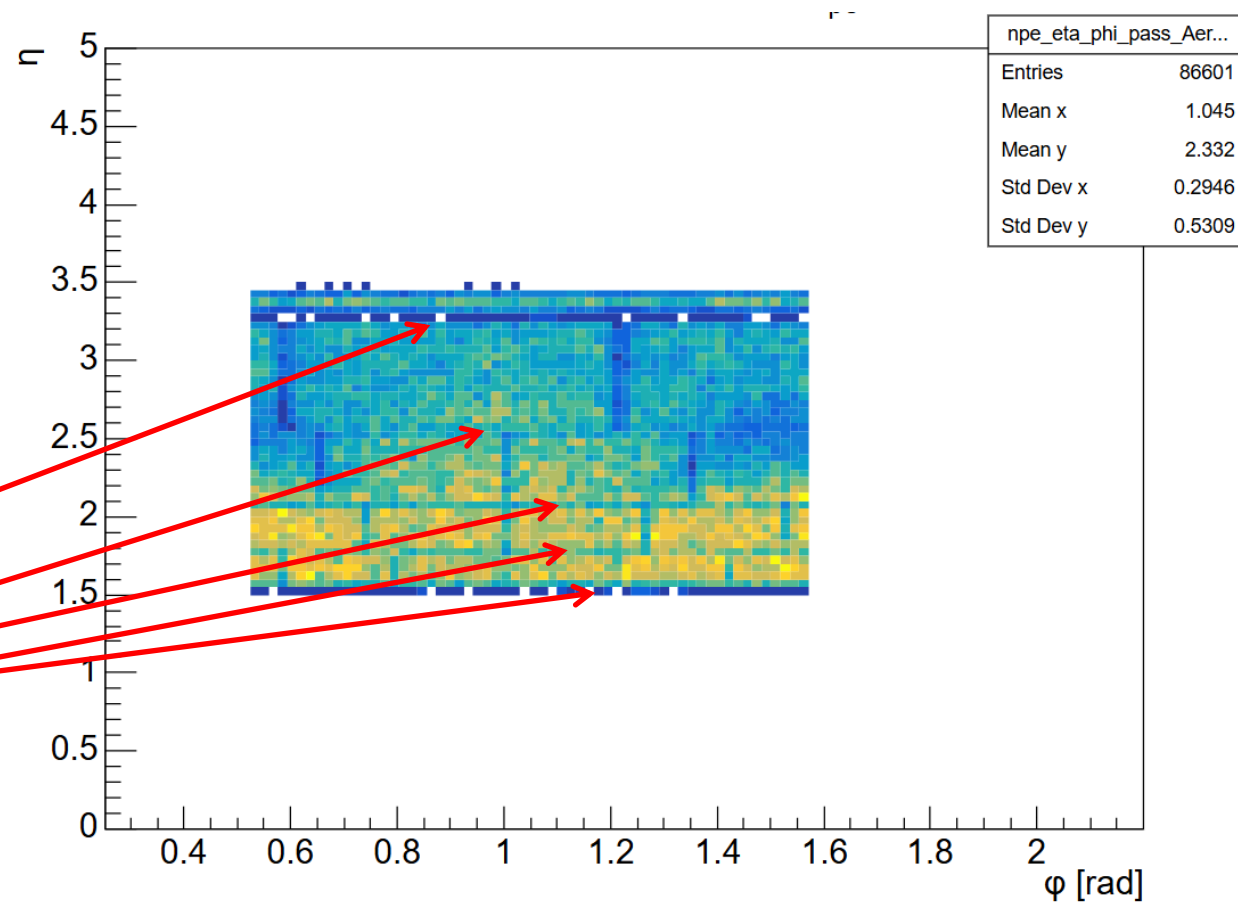
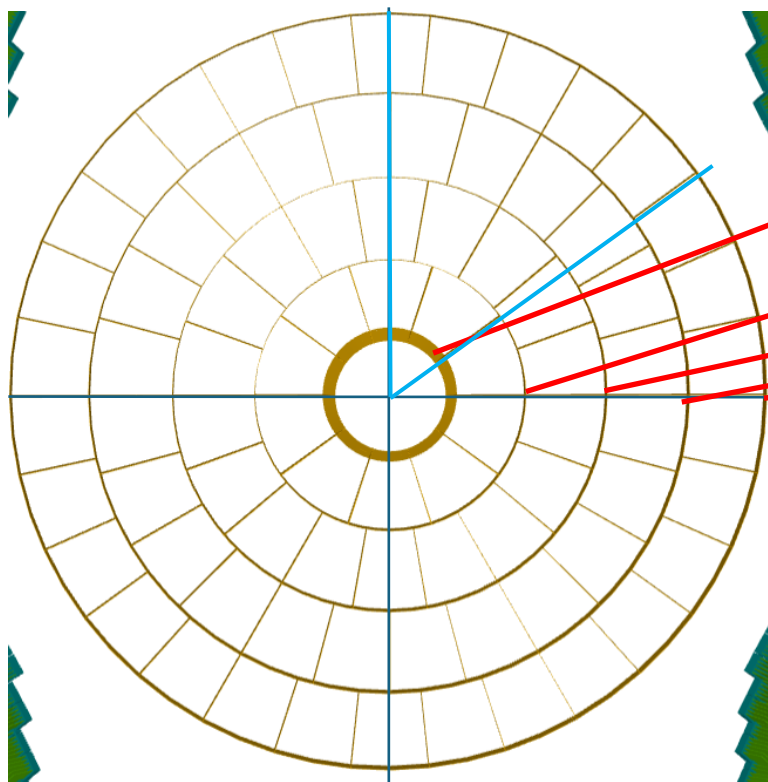

Acceptance performance

Looking into more details....

- ✓ 200k events.
- ✓ $n = 1.019$
- ✓ Particles 10 GeV/c momentum
- ✓ **$N_{pe} > 5$**
- ✓ $\phi \in [\pi/6, \pi/2]$
- ✓ $\eta \in [1.5, 3.5]$

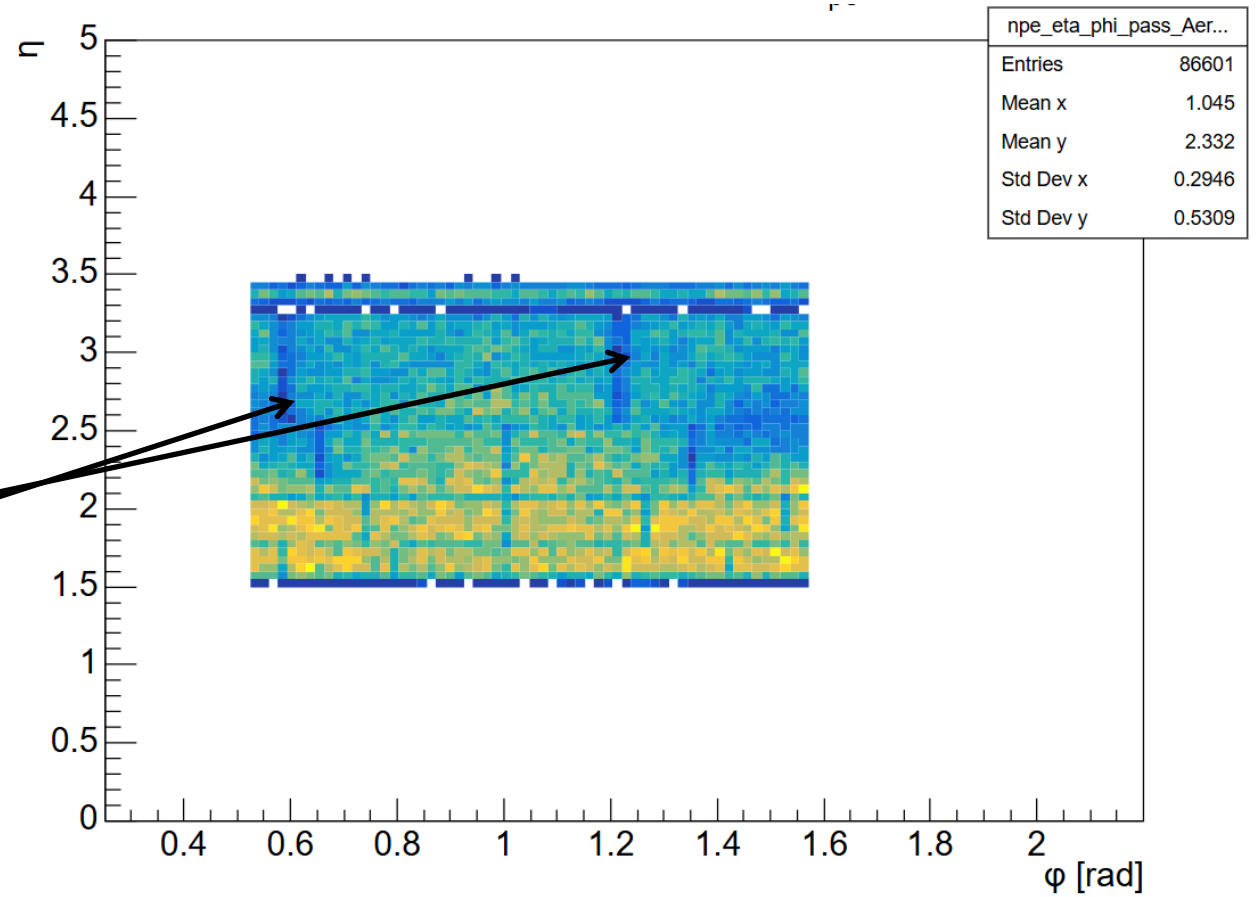
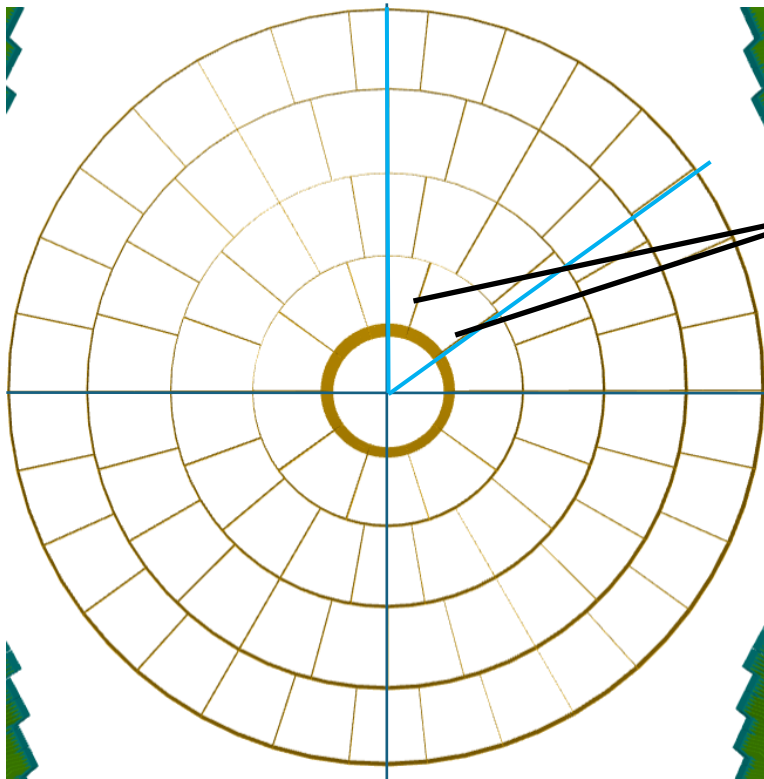

Acceptance performance

Looking into more details....

- ✓ 200k events.
- ✓ $n = 1.019$
- ✓ Particles 10 GeV/c momentum
- ✓ **$N_{pe} > 5$**
- ✓ $\phi \in [\pi/6, \pi/2]$
- ✓ $\eta \in [1.5, 3.5]$

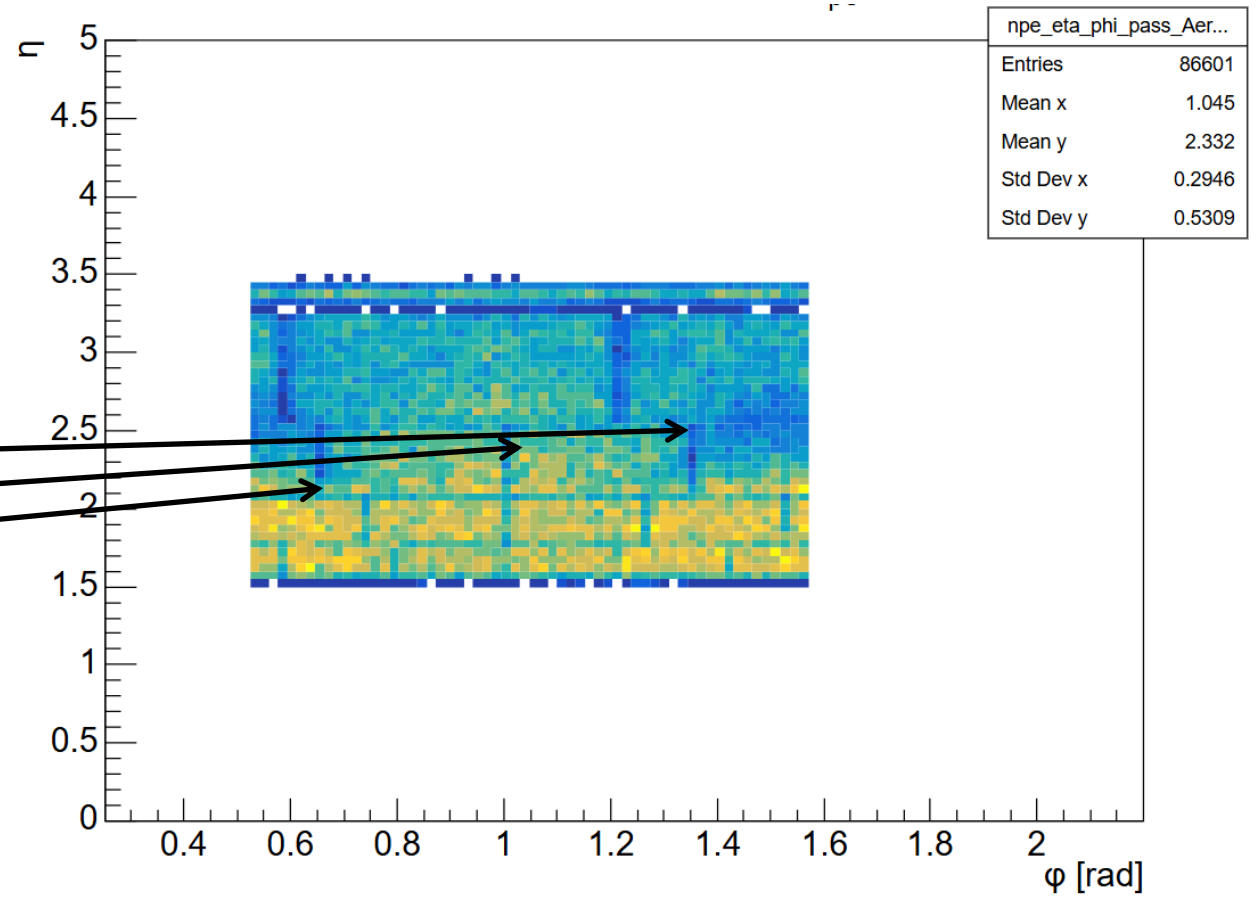
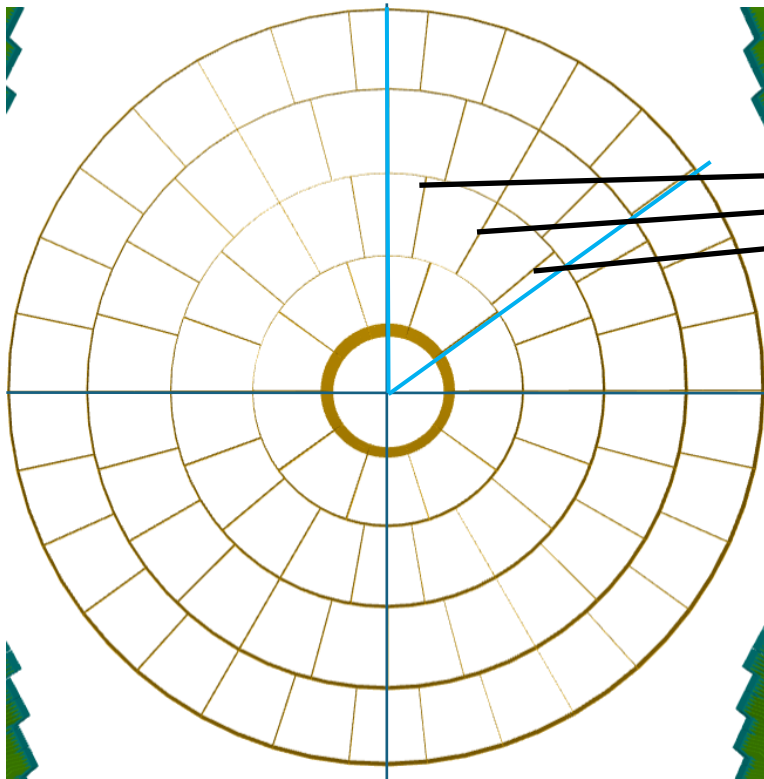

Acceptance performance

Looking into more details....

- ✓ 200k events.
- ✓ $n = 1.019$
- ✓ Particles 10 GeV/c momentum
- ✓ **$N_{pe} > 5$**
- ✓ $\phi \in [\pi/6, \pi/2]$
- ✓ $\eta \in [1.5, 3.5]$

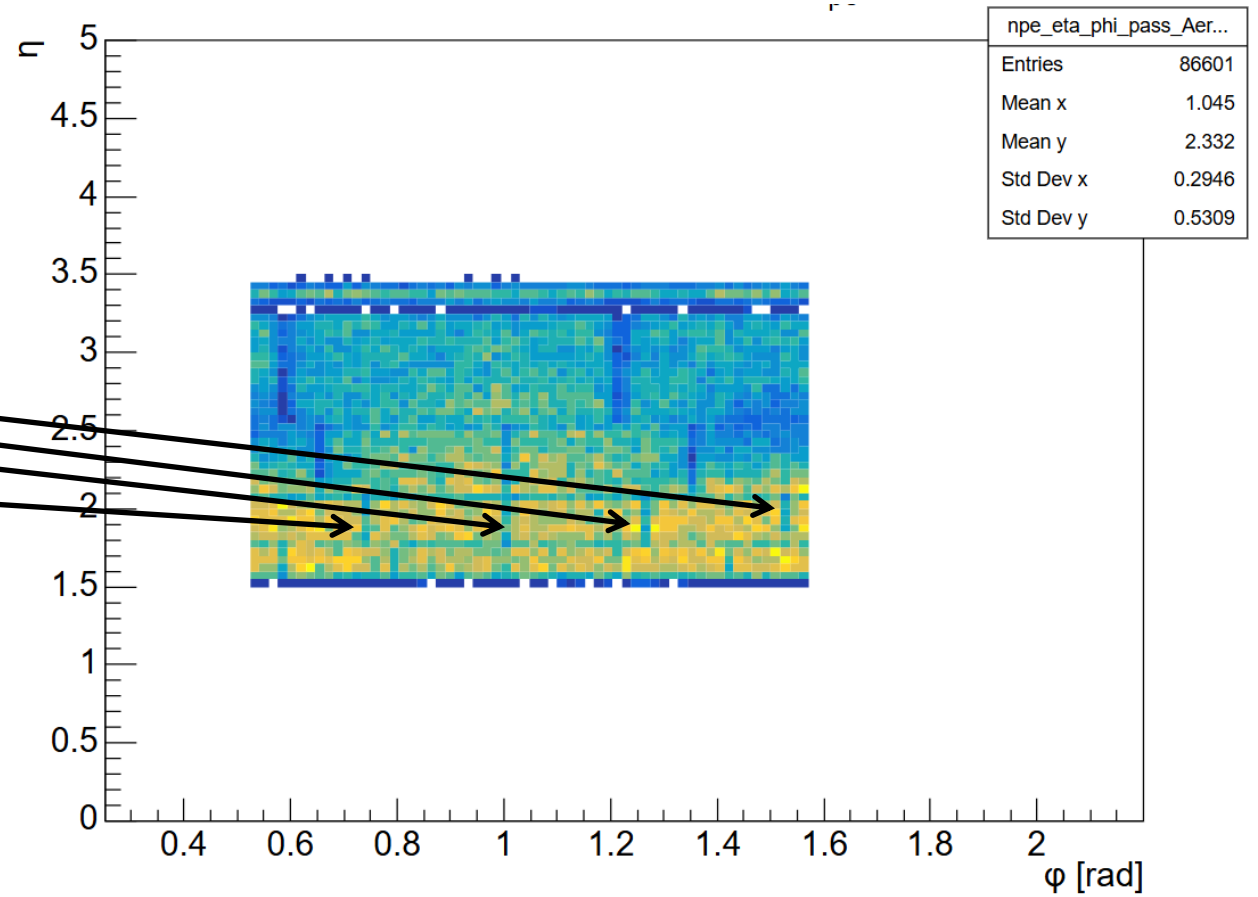
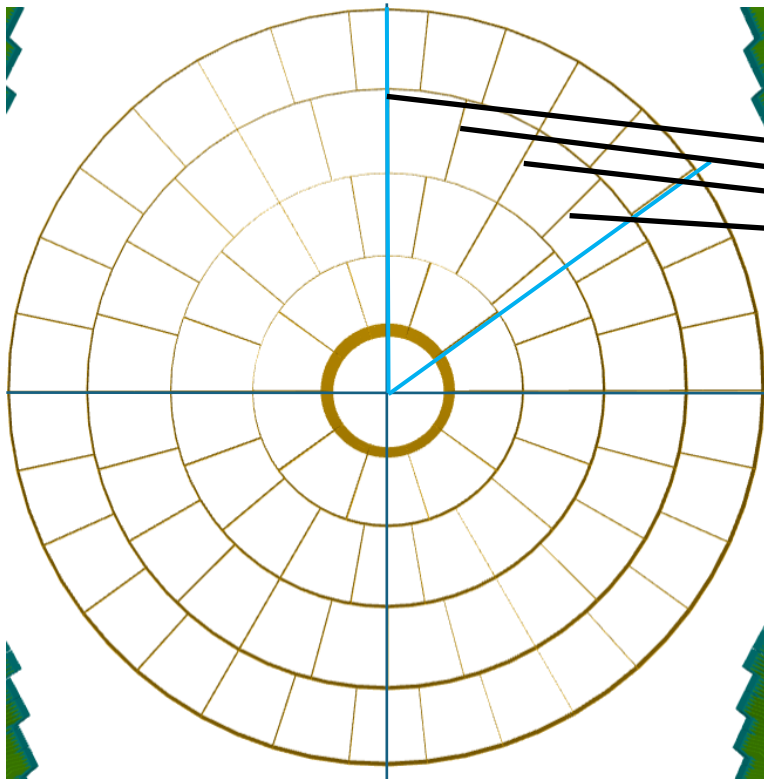

Acceptance performance

Looking into more details....

- ✓ 200k events.
- ✓ $n = 1.019$
- ✓ Particles 10 GeV/c momentum
- ✓ **$N_{pe} > 5$**
- ✓ $\phi \in [\pi/6, \pi/2]$
- ✓ $\eta \in [1.5, 3.5]$

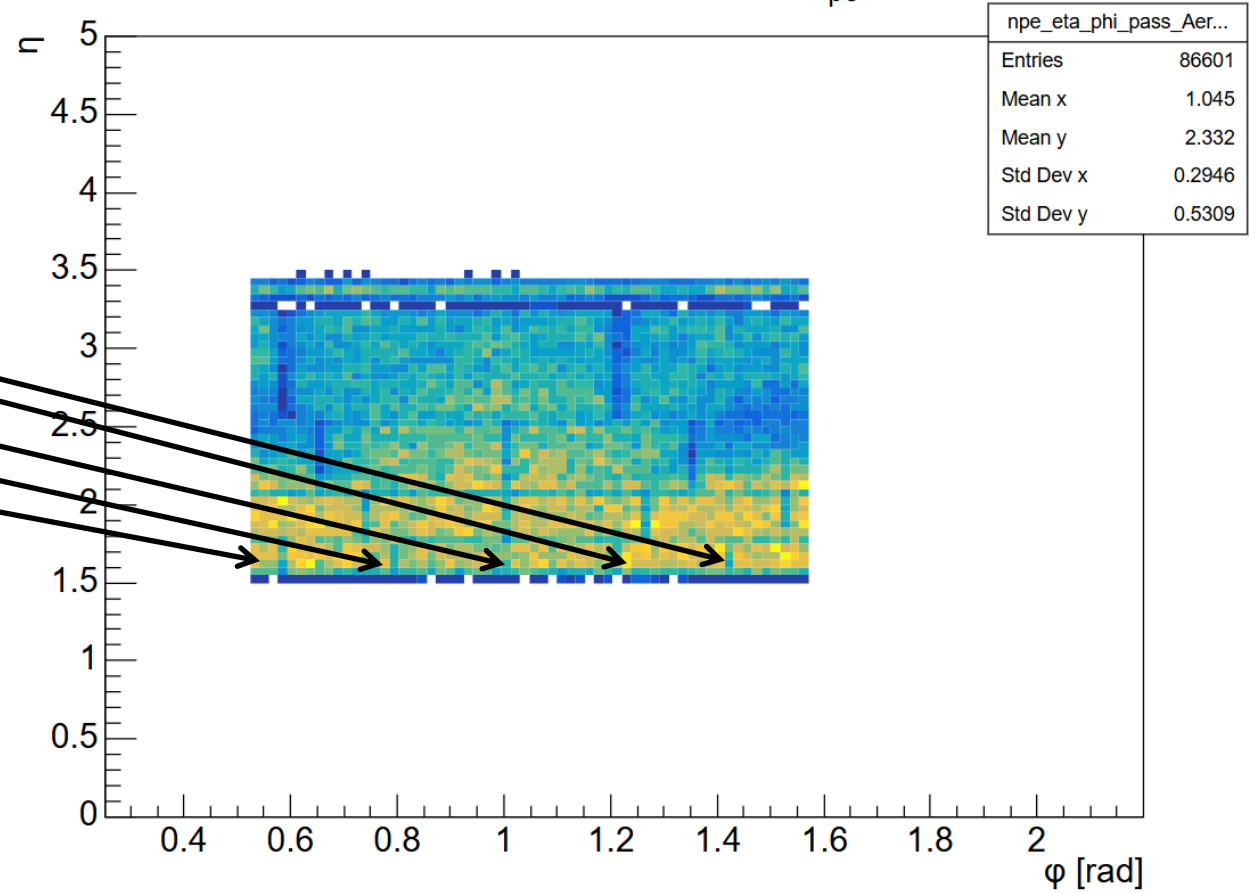
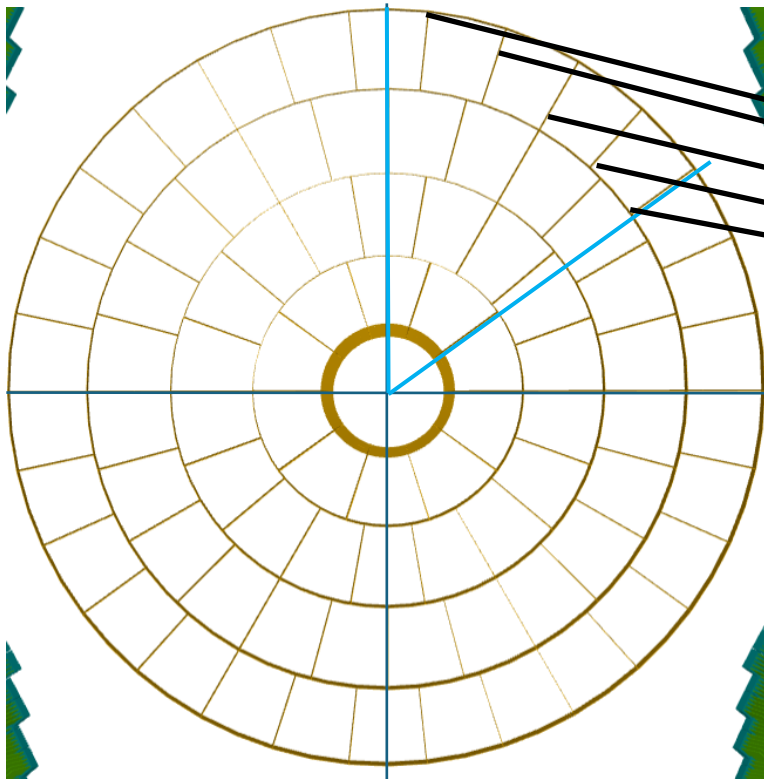

Acceptance x Efficiency performance

Looking into more details....

- ✓ 200k events.
- ✓ $n = 1.019$
- ✓ Particles 10 GeV/c momentum
- ✓ **$N_{pe} > 5$**
- ✓ $\phi \in [\pi/6, \pi/2]$
- ✓ $\eta \in [1.5, 3.5]$

Acceptance x Efficiency vs ϕ

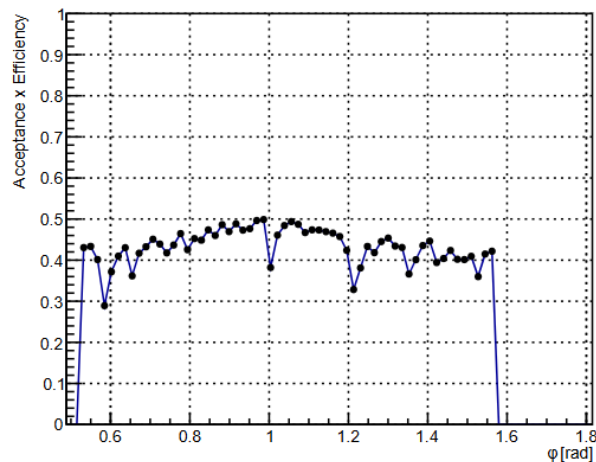

Acceptance x Efficiency vs η

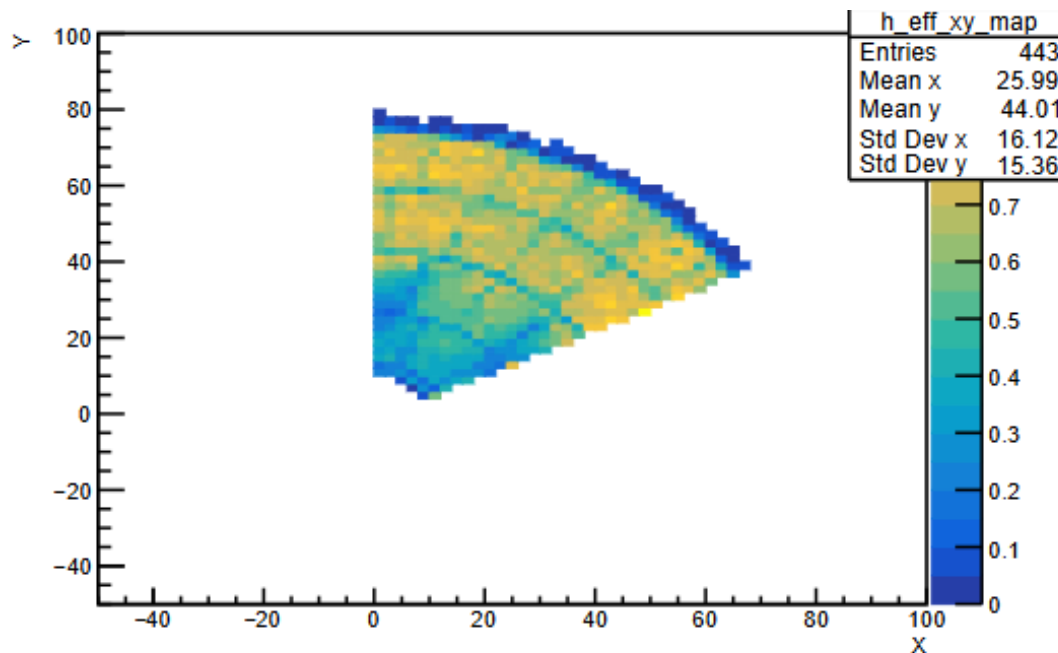
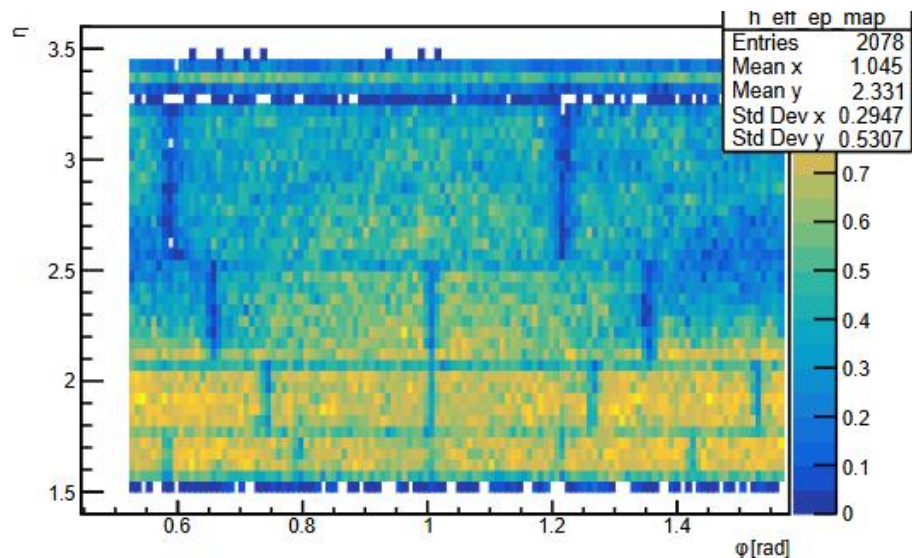
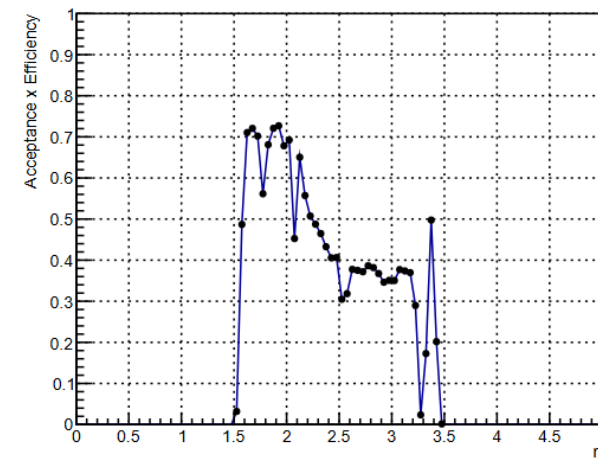

Acceptance x Efficiency performance

- ✓ 70k events.
- ✓ **n= 1.026**
- ✓ Particles 12.5 GeV/c momentum
- ✓ **N_{pe} > 7**
- ✓ $\phi \in [\pi/6, \pi/2]$
- ✓ $\eta \in [1.5, 3.5]$

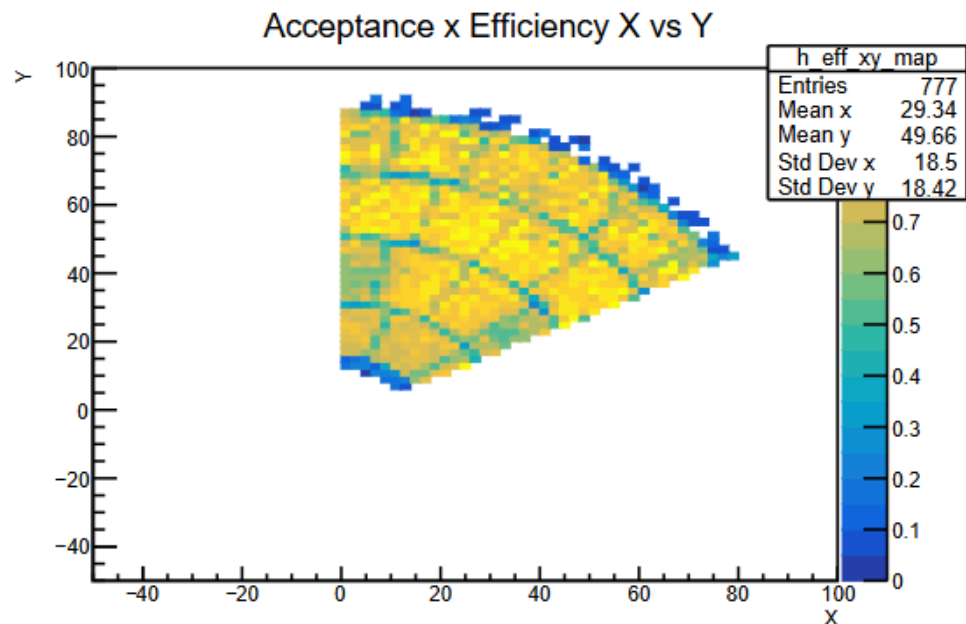
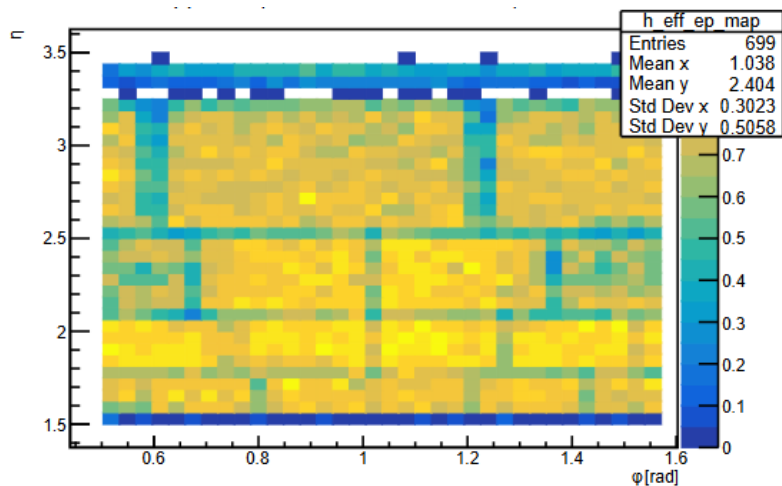
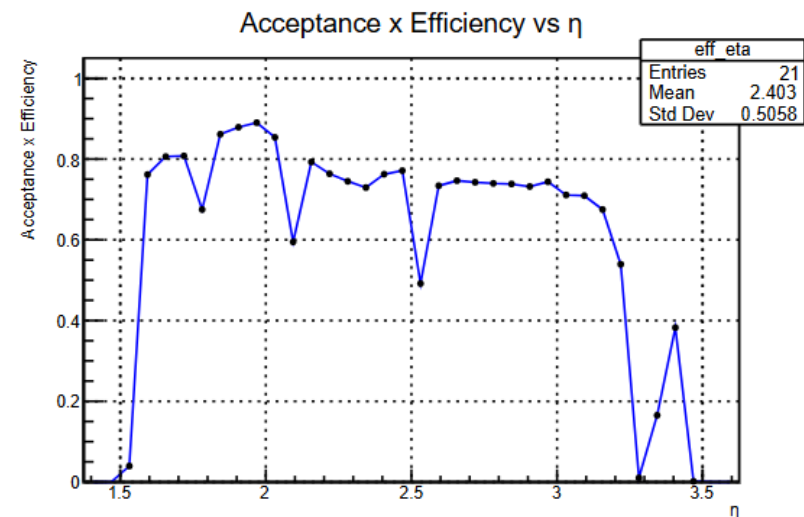
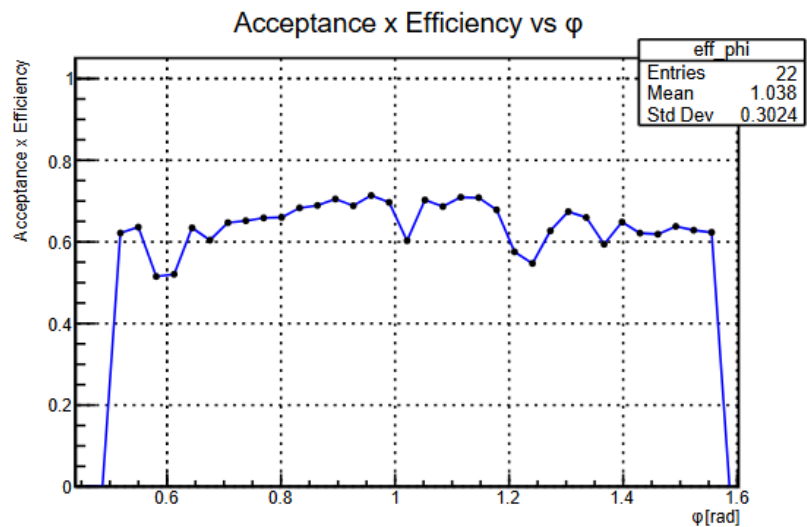

Realistic Event simulation & Occupancy studies

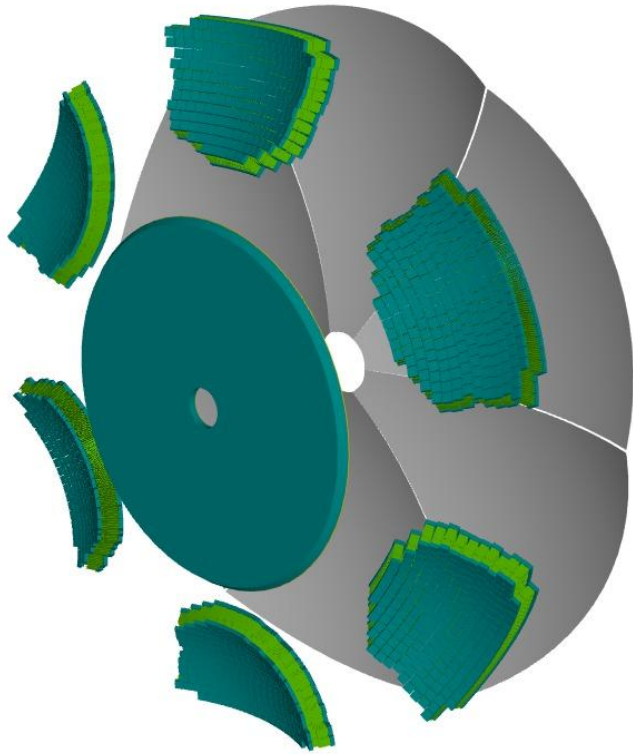

- ✓ From **Particle Gun** to Full Events with **Pythia**
- ✓ Multiplicity studies in dRICH acceptance
- ✓ Creating **2D maps** (Pseudorapidity vs. Azimuth Angle) to track particle flux distribution
- ✓ Sector-by-sector analysis: evaluation of particle multiplicity and occupancy estimation for each optical module (petal).



Summary

1. The aerogel with a refractive index of **$n=1.026$** produces a greater NPE compared to the aerogel with $n=1.019$ and provides better resolution at 3σ .
2. From the INFN group the aerogel characterization with $n=1.026$ is the best compromise between optical performance and spatial constraints
3. Chromatic aberration is identified as the primary source of angular resolution degradation per photon.
4. Robust code for implementing a carbon fiber structure to efficiently model the segmentation of the aerogel, with good acceptance.

Studies on going:

1. Several studies on the optimization and automatization of the code for the aerogel tiling
2. Multiplicity studies in dRICH acceptance

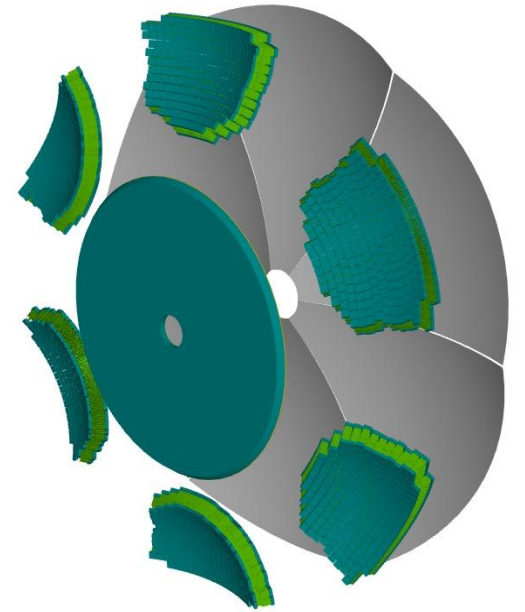

COSENZA

UNIVERSITÀ DELLA CALABRIA

THANKS!



UNIVERSITÀ
DELLA CALABRIA



ePIC and EIC Physics Readiness Workshop, Cosenza 17-19 March
2026

COSENZA

UNIVERSITÀ DELLA CALABRIA

Backup Slides



ePIC and EIC Physics Readiness Workshop, Cosenza 17-19 March
2026