

STAR Run 25 Report

Tristan Protzman, for the STAR collaboration
RHIC/AGS UEC 2026

May 12th, 2026



Supported in part by:



U.S. DEPARTMENT OF
ENERGY

Office of
Science



LEHIGH
UNIVERSITY



STAR had an excellent Run 25!

- Three periods of running
 - $\sqrt{s_{NN}} = 200$ GeV Au+Au
 - Three Au+Au fixed target energies: $\sqrt{s_{NN}} = 4.2, 4.5,$ and 5.2 GeV
 - $\sqrt{s_{NN}} = 200$ GeV O+O
- Excellent operations from STAR and RHIC enabled the collection of large datasets to support analyses well into the future
- Thank you to the entire C-AD department for the dedication over the long run!

| System | Minimum Bias Events | Luminosity |
|---------------------------------|---------------------|------------------------|
| $\sqrt{s_{NN}} = 200$ GeV Au+Au | 8.2 billion | 24.3 nb^{-1} |
| $\sqrt{s_{NN}} = 4.2$ GeV Au+Au | 292 million | --- |
| $\sqrt{s_{NN}} = 4.5$ GeV Au+Au | 1.04 billion | --- |
| $\sqrt{s_{NN}} = 5.2$ GeV Au+Au | 369 million | --- |
| $\sqrt{s_{NN}} = 200$ GeV O+O | 136 million | 34.4 nb^{-1} |

STAR physics



- Fundamental questions for the run 23 + 25 $\sqrt{s_{NN}} = 200$ GeV Au+Au collisions
 - What is the nature of the 3-dimensional initial state?
 - **What is the precise temperature dependence of the shear and bulk viscosities**
 - What can we learn about confinement from charmonium measurements?
 - What is the temperature of the medium?
 - What are the electrical, magnetic, and chiral properties of the medium?
 - What are the underlying mechanisms of jet quenching at RHIC energies?
 - What is the precise nature of the transition near $\mu_B = 0$?
 - What can we learn about the strong interaction?
 - Understanding the photoproduction of vector-mesons and dijets
 - Searching for collectivity and baryon-junction signatures in photo-nuclear processes



Projections for $v_2(\eta)$

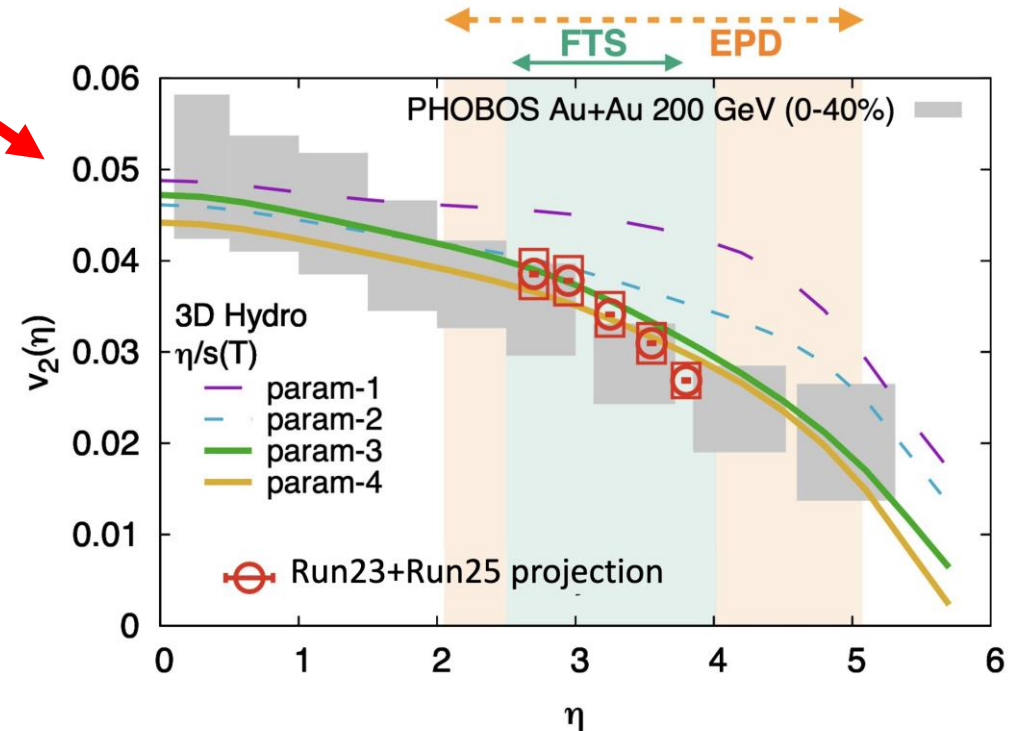

STAR Run 25 Beam Use Request

STAR physics



- Fundamental questions for the run 23 + 25 $\sqrt{s_{NN}} = 200$ GeV Au+Au collisions
 - What is the nature of the 3-dimensional initial state?
 - What is the precise temperature dependence of the shear and bulk viscosities
 - What can we learn about confinement from charmonium measurements?
 - What is the temperature of the medium?
 - What are the electrical, magnetic, and chiral properties of the medium?
 - **What are the underlying mechanisms of jet quenching at RHIC energies?**
 - What is the precise nature of the transition near $\mu_B = 0$?
 - What can we learn about the strong interaction?
 - Understanding the photoproduction of vector-mesons and dijets
 - Searching for collectivity and baryon-junction signatures in photo-nuclear processes



Projections for jet acoplanarity

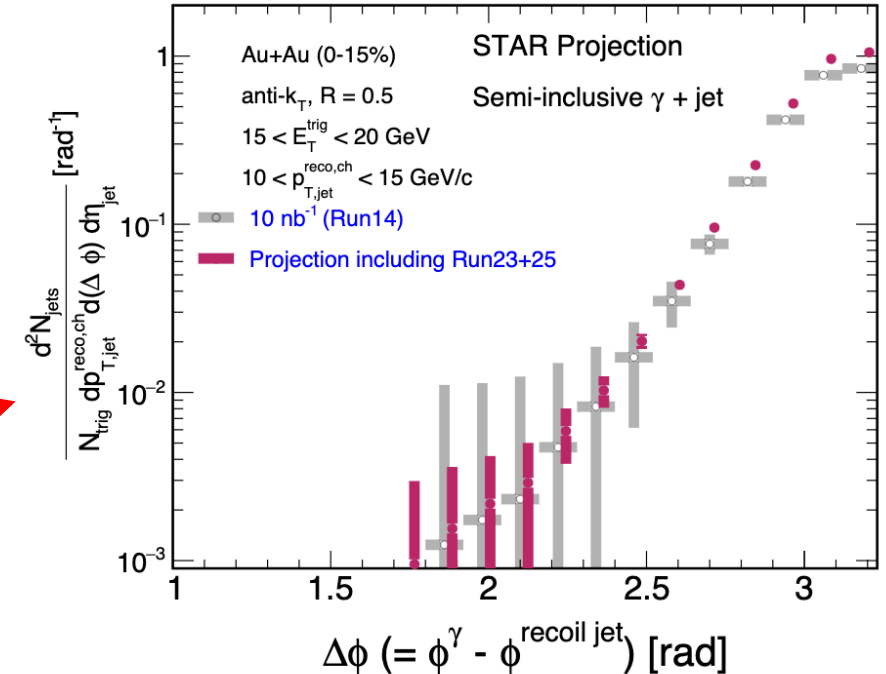

STAR Run 25 Beam Use Request

STAR physics



- Fundamental questions for the run 23 + 25 $\sqrt{s_{NN}} = 200$ GeV Au+Au collisions
 - What is the nature of the 3-dimensional initial state?
 - What is the precise temperature dependence of the shear and bulk viscosities
 - What can we learn about confinement from charmonium measurements?
 - What is the temperature of the medium?
 - What are the electrical, magnetic, and chiral properties of the medium?
 - What are the underlying mechanisms of jet quenching at RHIC energies?
 - What is the precise nature of the transition near $\mu_B = 0$?
 - What can we learn about the strong interaction?
 - Understanding the photoproduction of vector-mesons and dijets
 - **Searching for collectivity and baryon-junction signatures in photo-nuclear processes**

Projections for per-trigger yield in photonuclear processes

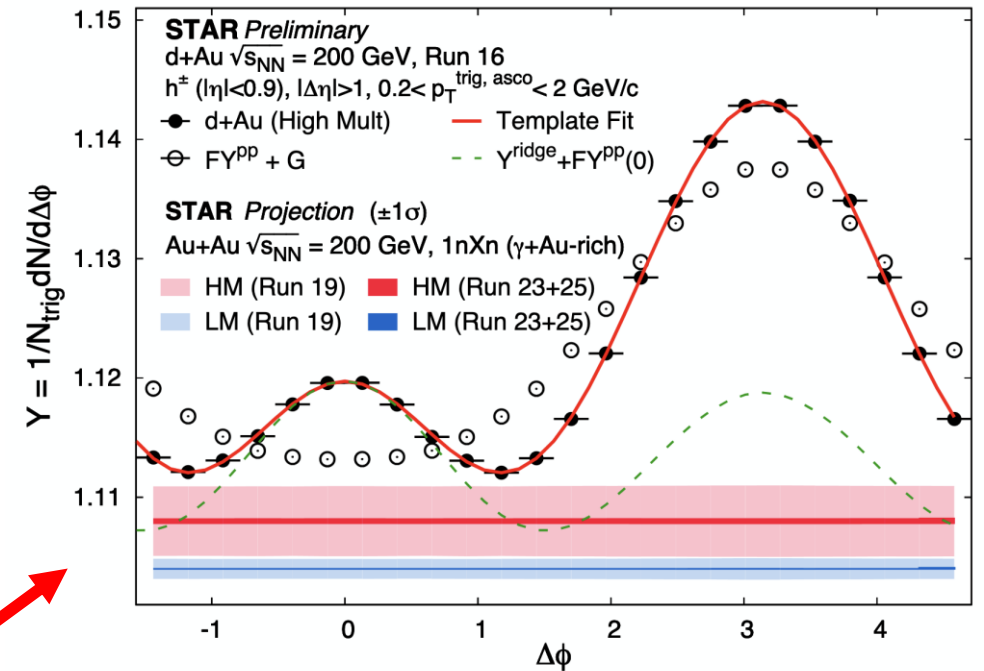

STAR Run 25 Beam Use Request

Improvements



- STAR was well configured to answer these questions
- In comparison to the last large $\sqrt{s_{NN}} = 200$ GeV Au+Au collisions in 2016...
- DAQ upgrades
 - ~2x data rate
 - Improve both minimum bias statistics and sampleable luminosity by rare probes triggers
- Extended detector acceptance
 - BES-II upgrades include the iTPC, eTOF, and EPD
 - Forward upgrade adds charged particle tracking, electromagnetic, and hadronic calorimetry for the range $2.5 \leq \eta \leq 4$
- Reduced material budget
 - The inner silicon tracker (HFT) has been removed, improving sensitivity for dielectron measurements

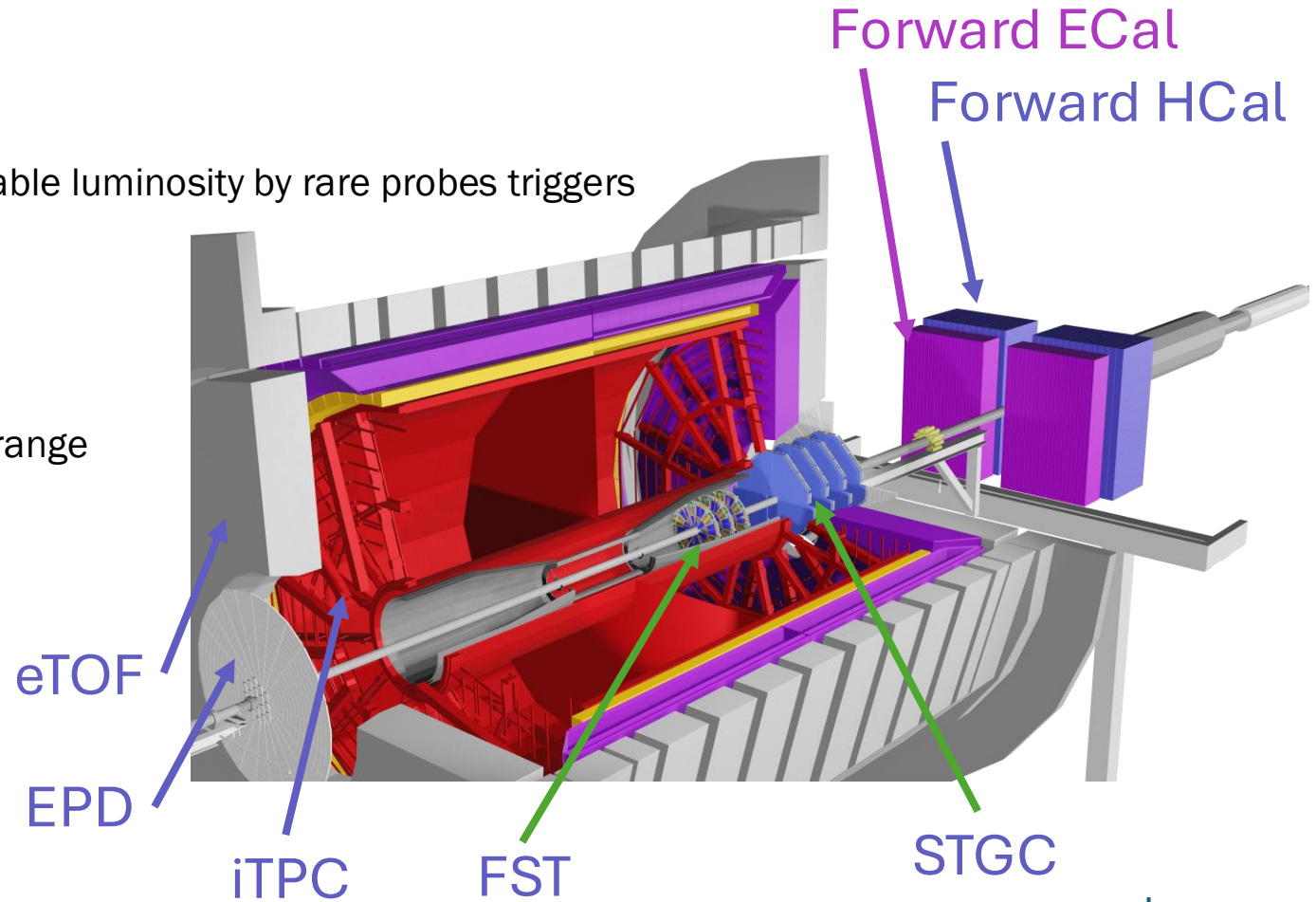

STAR beam use request



- Run 25 request in support of a legacy dataset combining Runs 23-25, delivering a large Au+Au and p+p sample to support future analyses
- STAR requested 9 billion minimum bias Au+Au events and 28.6 nb^{-1} of sampled luminosity

| Observable | Question | PWG | MB/H \mathcal{L} | Coverage | Trigger |
|-----------------------------|---------------------|--------|--------------------|-----------------------|---------------|
| $v_2(\eta)$ Twist | 1) Initial State | FCV | Min bias | iTPC, TOF, EPD, FTS | MB |
| $r_n(\eta_a, \eta_b)$ | 1) Initial State | FCV | Min Bias | iTPC, TOF, EPD, FTS | MB |
| $J/\psi v_1$ | 1) Initial State | HP | Luminosity | iTPC, TOF, EPD | MB+BHT |
| Photon WF | 1) Initial State | LFSUPC | Min Bias | iTPC, TOF | MB |
| $v_2(\eta)$ | 2) Viscosity | FCV | Min bias | iTPC, TOF, EPD, FTS | MB |
| $J/\psi v_2$ | 3) Deconfinement | HP | Luminosity | iTPC, TOF, EPD | MB+BHT |
| Υ Suppression | 4) Temperature | HP | Luminosity | iTPC, TOF | BHT+Dimuon |
| $\psi(2s)$ suppress. | 4) Temperature | HP | Min Bias | iTPC, TOF | MB |
| Di-elec IMR | 4) Temperature | LFSUPC | Min Bias | iTPC, TOF | MB |
| $P_H(\eta)$ | 5) Properties | FCV | Min Bias | iTPC, TOF, FTS, EPD | MB |
| P_H of J/ψ | 5) Properties | FCV | Luminosity | iTPC, TOF, EPD | MB+BHT |
| $\rho^0 a_1$ mixing | 5) Properties | LFSUPC | Min Bias | iTPC, TOF | MB |
| | 5) Properties | LFSUPC | Min Bias | iTPC, TOF | MB |
| | 5) Properties | FCV | Min Bias | iTPC, TOF, EPD | MB |
| | 6) Jet quenching | HP | Luminosity | BEMC, EEMC, FCS | BHT |
| | 6) Jet quenching | HP | Luminosity | BEMC, EEMC, FCS | BHT |
| | 6) Jet quenching | HP | Luminosity | BEMC, EEMC, FCS | BHT |
| | 7) Phase Transition | CF | Min Bias | iTPC, TOF | MB |
| | 8) Strong Interact. | CF | Min Bias | iTPC, TOF | MB |
| baryon CP | | | | | |
| UPC $\rho^0, \phi, J/\psi$ | UPC – CNM | LFSUPC | Luminosity | iTPC, TOF, BEMC, EEMC | ZDCEW, UPC |
| v_2 in γ +Au (UPC) | UPC – CNM | FCV | Min Bias | iTPC, TOF, FTS | UPC |
| UPC di-jets | UPC – CNM | HP | Luminosity | iTPC, TOF, BEMC | UPC+BHT |
| UPC CP spectra | UPC – CNM | LFSUPC | Min Bias | iTPC, TOF | ZDCE(1n)+ZDCW |

| Species | Min-Bias Events | Sampled Luminosity | Condition |
|---------------------------------------|-----------------|------------------------|---------------|
| $\sqrt{s_{NN}}=200 \text{ GeV Au+Au}$ | 5 Billion | 20.8 nb^{-1} | 20 cryo-weeks |
| $\sqrt{s_{NN}}=200 \text{ GeV Au+Au}$ | 9 Billion | 28.6 nb^{-1} | 28 cryo-weeks |



Run 25 – Initial schedule

- Run 25 was initially scheduled from March 15 through December 22
- A six week summer break was scheduled to avoid running during the hottest weeks of the summer
- A short circuit was discovered in the blue ring magnets during commissioning
 - Necessitated warming the ring to access cryostats around IP4
 - A metal protrusion was located at the end of a DX magnet
 - Once found and repaired, the cooldown could restart



Planned Schedule

- March 15, 2025 – Start of STAR shifts
- March 24, 2025 – 4k cooldown
- March 25, 2025 – Full STAR shifts
- March 31, 2025 – First $\sqrt{s_{NN}} = 200$ GeV Au+Au collisions
- June 30, 2025 – Start of six week summer break
- August 18, 2025 – Resume $\sqrt{s_{NN}} = 200$ GeV Au+Au collisions
- December 22, 2025 – Last collisions, depending on FY26 funding levels

Run 25– Actual timeline



- March 15, 2025 – Start of STAR shifts
- March 24, 2025 – 4k cooldown
- March 25, 2025 – Full shift crews at STAR
- April 1, 2025 - Short discovered in blue ring
- April 4, 2025 – STAR shifts suspended
- May 15, 2025 – RHIC cooldown restarted
- May 20, 2025 – STAR operations resumed
- June 3, 2025 – 4k cooldown
- June 9, 2025 – First $\sqrt{s_{NN}} = 200$ GeV Au+Au collisions
- June 17, 2025 – All triggers promoted to production status
- August 26, 2025 – RHIC transmission line damage discovered, requiring emergency repairs
- September 26, 2025 – Abort kicker prefire broke vacuum
- December 8, 2025 – Last $\sqrt{s_{NN}} = 200$ GeV Au+Au collisions, switch to $\sqrt{s_{NN}} = 200$ GeV p+p
- January 21, 2026 – $\sqrt{s_{NN}} = 4.5$ GeV Au+Au collisions
- January 25, 2026 – $\sqrt{s_{NN}} = 4.2$ GeV Au+Au collisions
- January 26 2026 – $\sqrt{s_{NN}} = 5.2$ GeV Au+Au collisions
- January 31, 2026 – $\sqrt{s_{NN}} = 200$ GeV O+O collisions
- February 6, 2026 – Final collisions!

*Last year's
AUM!*

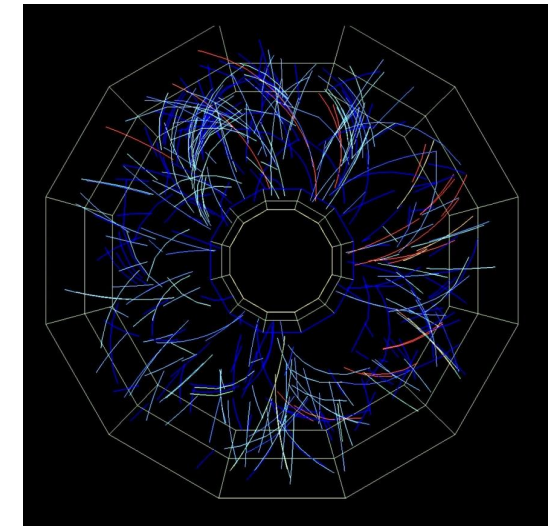
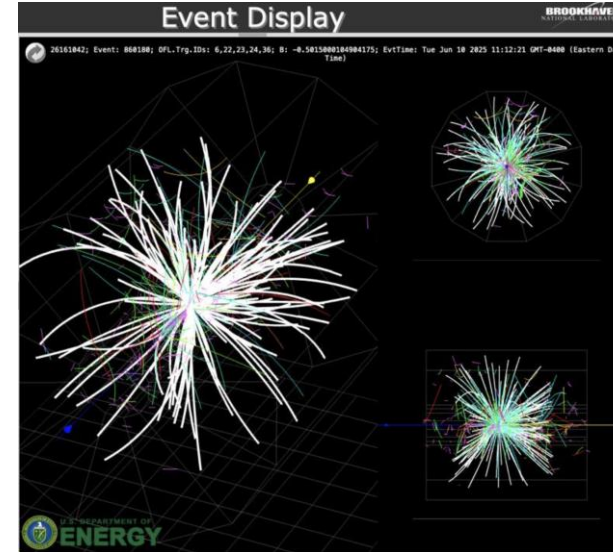

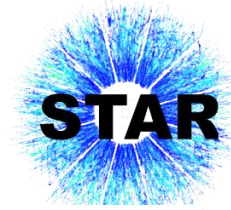

Run period 1: top energy Au+Au

- Last opportunity for $\sqrt{s_{NN}} = 200$ GeV Au+Au collisions
- Typically had a 6 hour fill duration
- Two running modes
- 4 hours of high luminosity
 - Leveling at 100 kHz ZDC rate
 - No beam crossing angle
 - Focus on jets and rare probes physics
- 2 hours of low luminosity
 - Leveling at 13 kHz ZDC rate
 - 1 milliradian crossing angle
 - Lower background, focus on minimum bias physics

Fill 36369

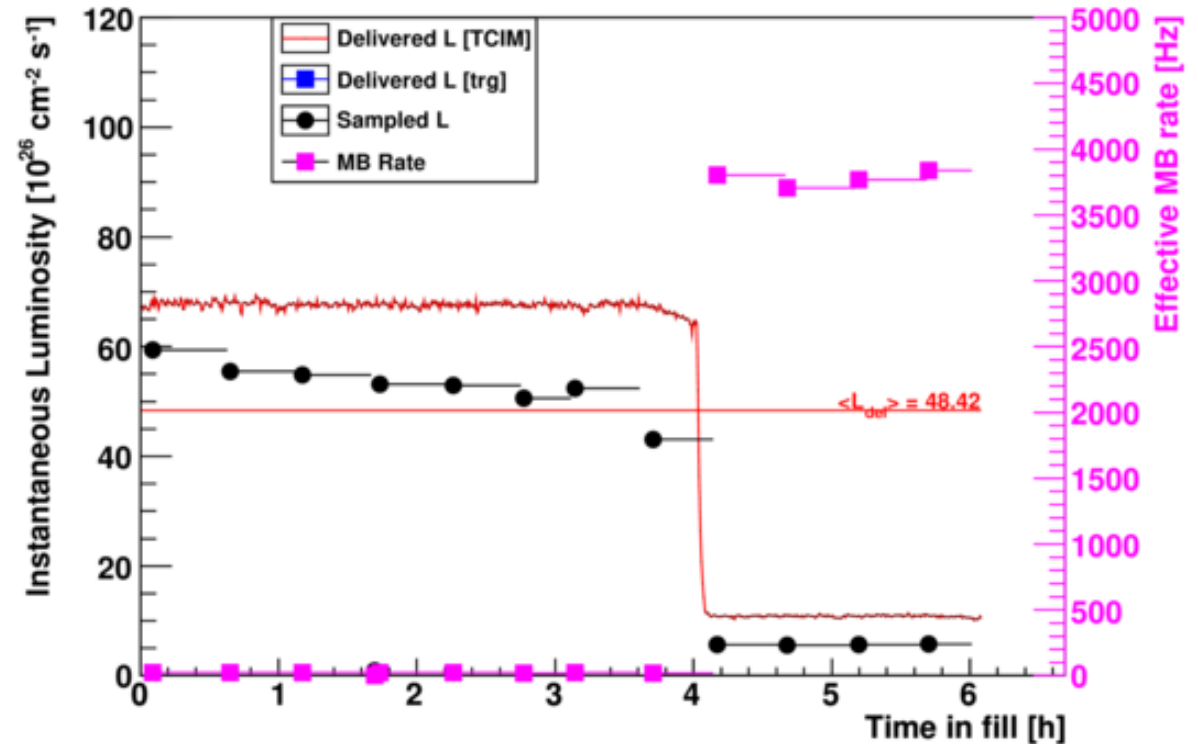

Leveling at 100 kHz
High luminosity

Leveling at 13 kHz
Low luminosity

Au+Au challenges – magnet cooling



- Between June 23rd and July 31st, the magnet cooling was insufficient to maintain the full 0.5 T field during the hottest parts of the day
- To avoid magnet trips, the field can be reduced to 0.25 T, reducing the load on the cooling system
- Trigger selection modified to focus on UPC physics
 - 22 hours of running, ~260 million events
- Even with operational issues, STAR maximized every physics opportunity we had

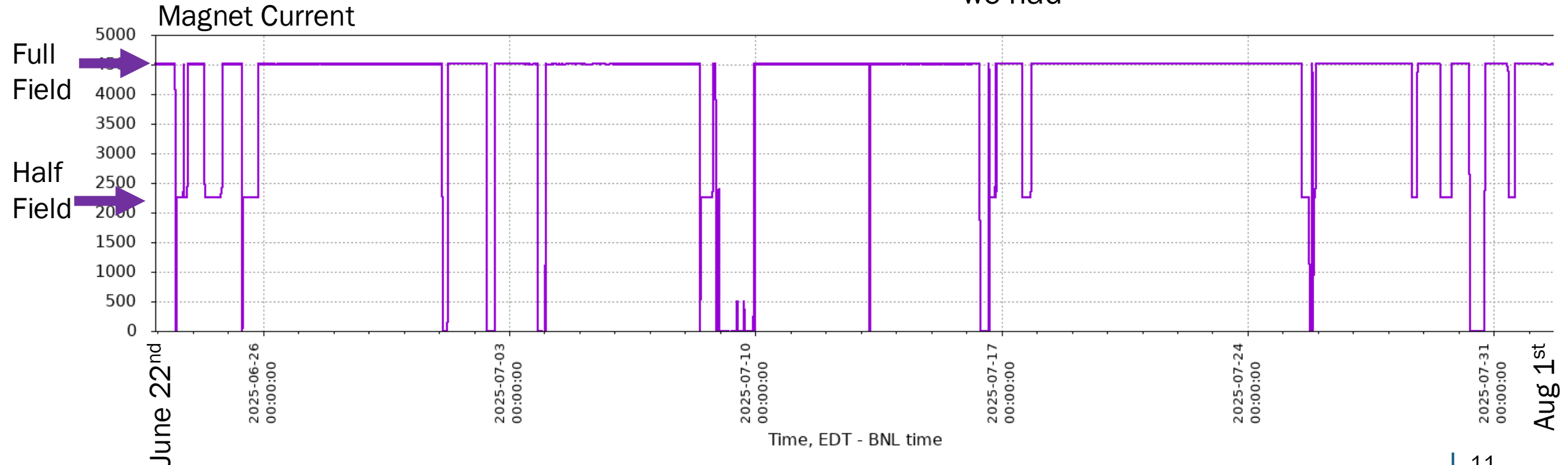

Au+Au challenges – Transmission line issues and MCW leak



- Damage to the power pole carrying the 69 kV line for the RHIC facility required downtime starting August 26th
 - Required warming up RHIC, setting up STAR for no one to be in the control room
- The same day, a water leak was discovered in the west pole tip of STAR
- The VPD, BBC, and EPD were all removed and the west pole tip was opened, the leak was patched on the 27th
- Opportunistically, the east pole tip was opened and the eTOF was removed for repair – more details later
- After time to dry, the STAR pole tips were closed again getting STAR ready to resume operations
- An issue with a soft start relay in the magnet power supply caused some delay restoring the magnet
- Beam was returned September 10th, STAR was collecting physics data by the 11th

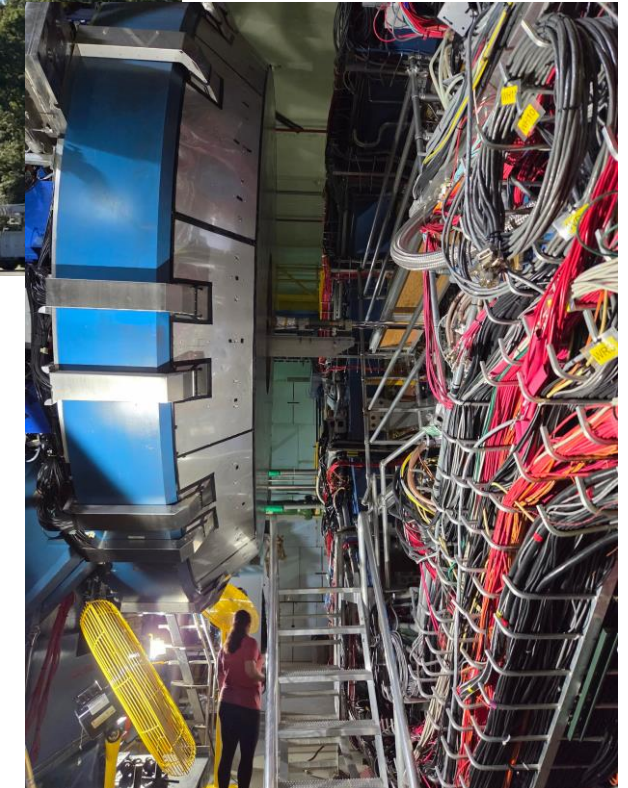

RHIC and STAR ran very well through Au+Au collisions

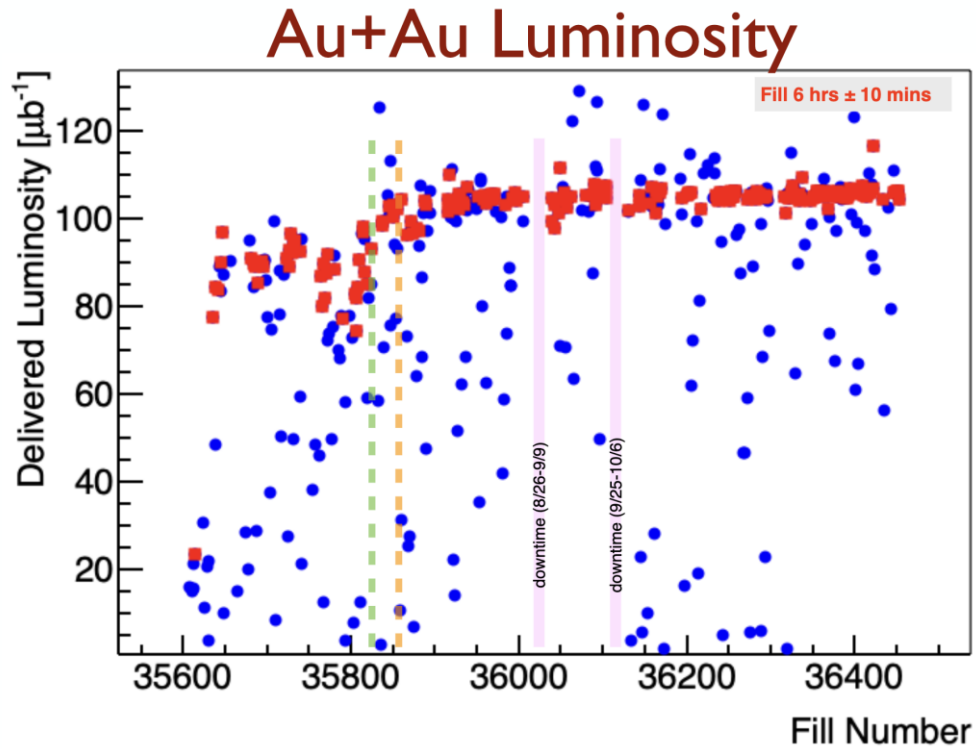

Added yellow horizontal stochastic cooling plane
Removed hidden 0.1 mrad crossing angle

Fraction of Hours delivered while taking data

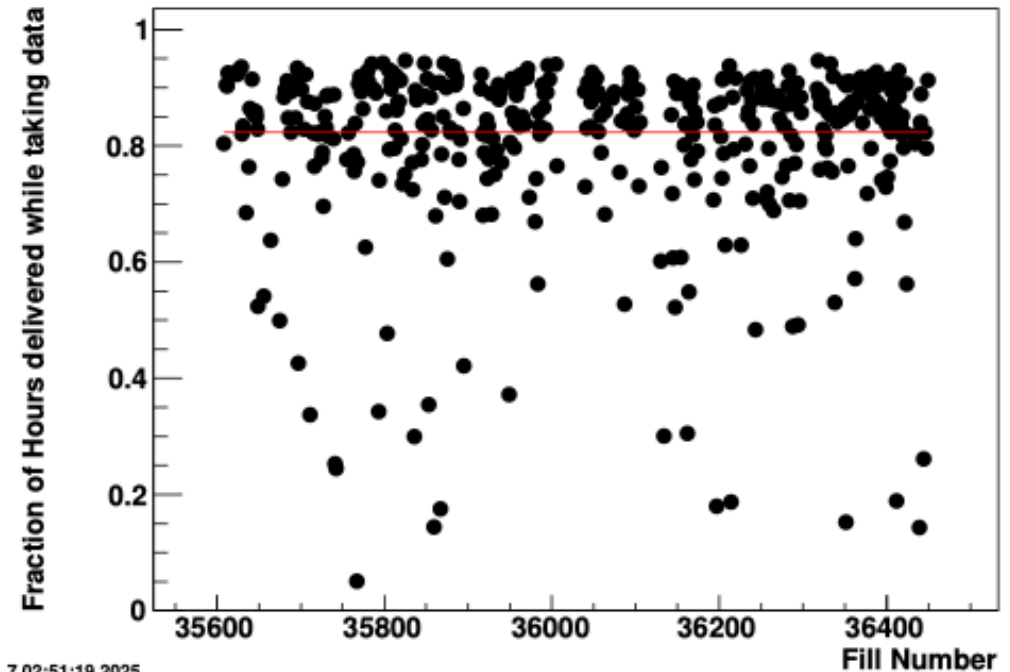

- RHIC quickly and consistently delivered collisions
- STAR collected data 83% of the time collisions were delivered (86% during 6 hour fills)
- An excellent $\sqrt{s_{NN}} = 200$ GeV Au+Au dataset was collected by STAR!

Au+Au performance

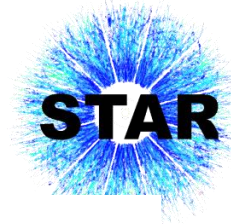

Minimum Bias Events

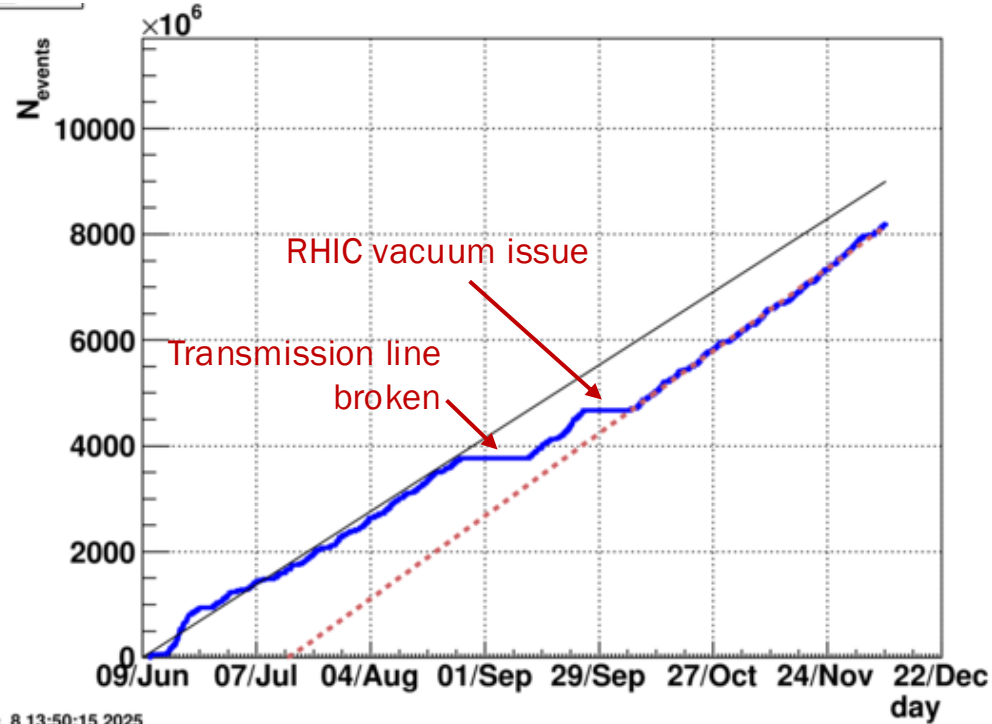

Sampled Luminosity

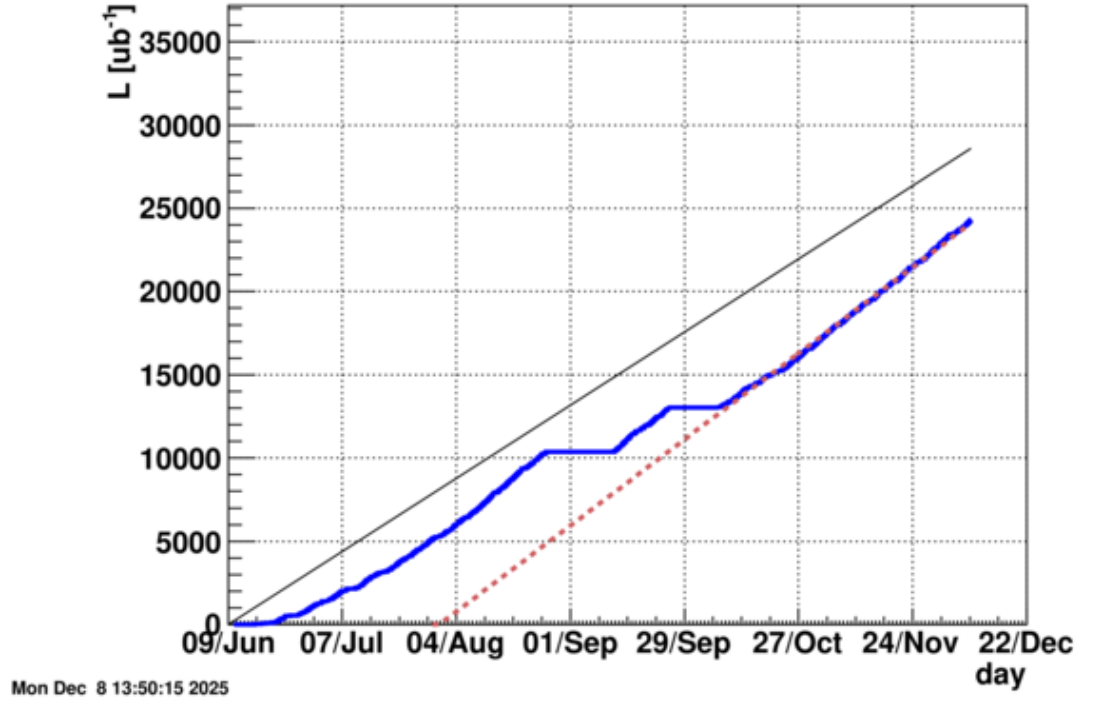

- 182 days of running, 152 days of physics
 - June 9th through December 8th
- 8.2 billion minimum bias events
- 24.3 nb^{-1} sampled by high p_T triggers

- 91% of minimum bias goal reached!
- 85% of high p_T goal reached!

STAR takes a short nap...



- RHIC circulated polarized proton beams from December 8th, 2025 through January 20th, 2026
- STAR did not collect data during this period
- The magnet was left on at low field for beam optics considerations
- To “wake” STAR up, beam-gas collisions were collected in the last week of $p + p$ collisions
 - Emulating the fixed target running to come
- An external chiller was also installed to supplement STARs cooling capacity to avoid downtime during critical last weeks of running

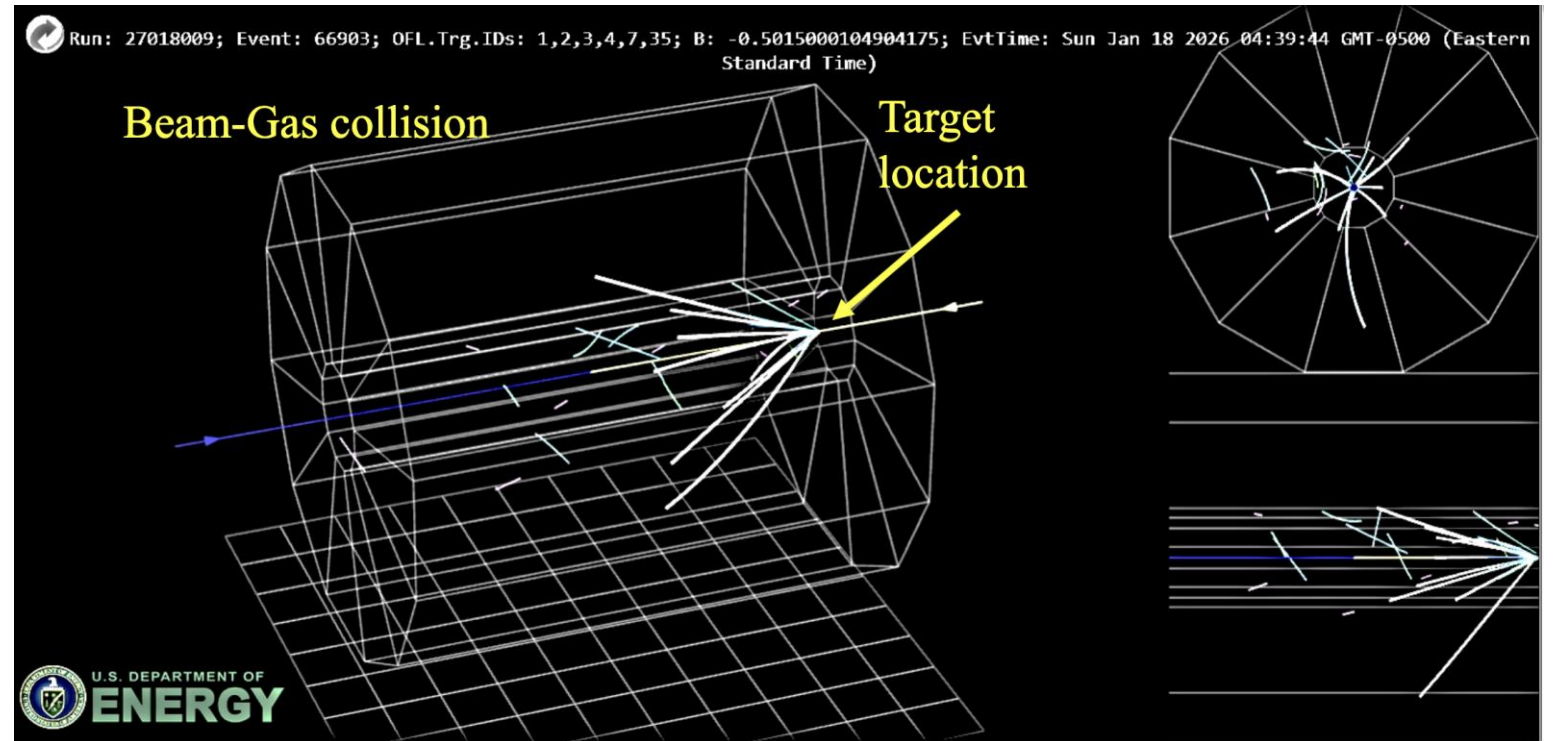

eTOF repair

- The Endcap Time of Flight detector assists in particle identification in the endcap region
- The detector electronics had been damaged since the last fixed target running
- During the unexpected downtime from the transmission line, the east pole tip was opened and the eTOF was removed
- Replacement electronics were delivered from GSI and installed in the removed detectors
- During the downtime from the vacuum issue, the east pole tip was opened and the detector reinstalled

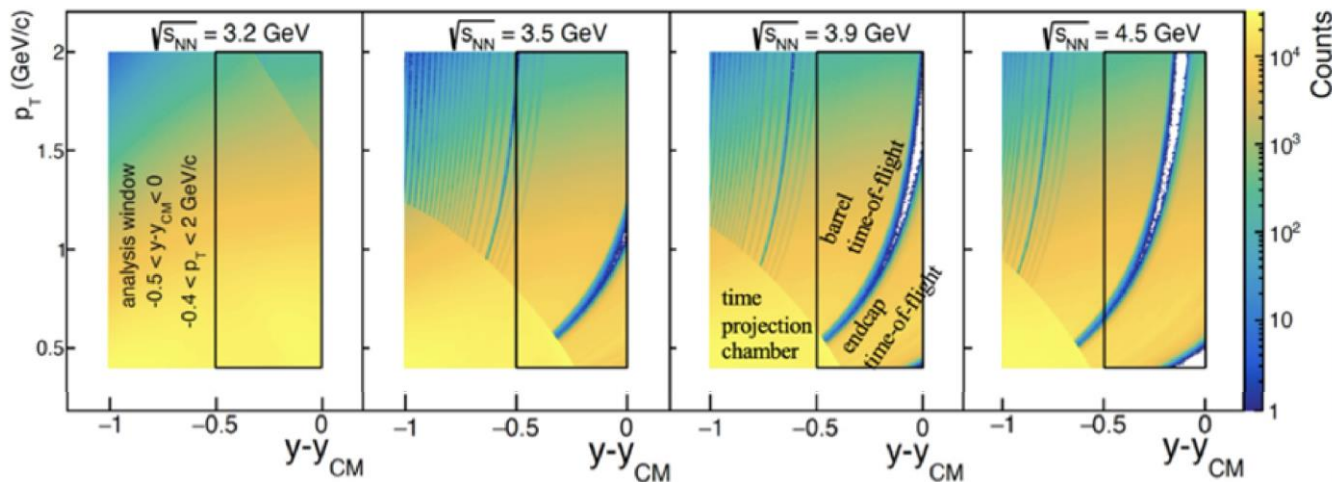

eTOF

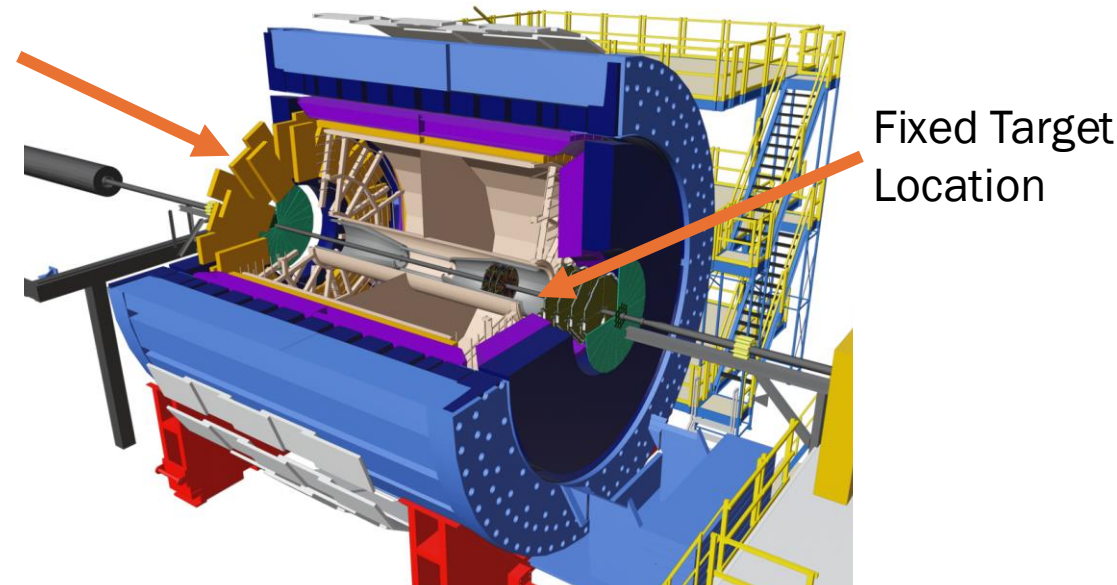



Run period 2: Fixed target running

- A longstanding STAR goal is to determine the existence and location of the conjectured QCD critical point
- UrQMD baselines for net proton kurtosis agree with fixed target data at $\sqrt{s_{NN}} = 3.0, 3.2, 3.5,$ and 3.9 GeV
- To investigate the significance of a 2σ deviation at $\sqrt{s_{NN}} = 4.5$ GeV, running at $\sqrt{s_{NN}} = 4.2, 4.5$ and 5.2 GeV was collected
- 292 million, 1.04 billion, and 369 million minimum bias events were collected at each energy respectively

Minimum Bias Events $\sqrt{s_{NN}} = 4.5$ GeV

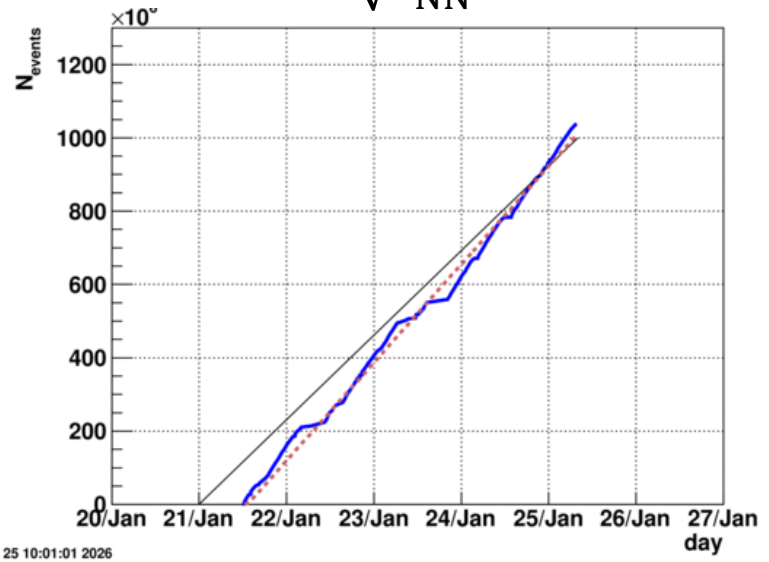

Sun Jan 25 10:01:01 2026

Minimum Bias Events $\sqrt{s_{NN}} = 4.2$ GeV

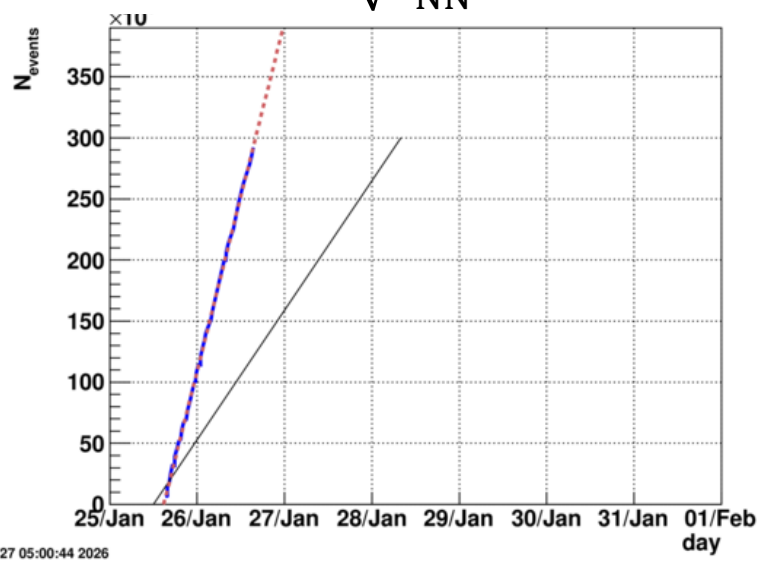

Tue Jan 27 05:00:44 2026

Minimum Bias Events $\sqrt{s_{NN}} = 5.2$ GeV

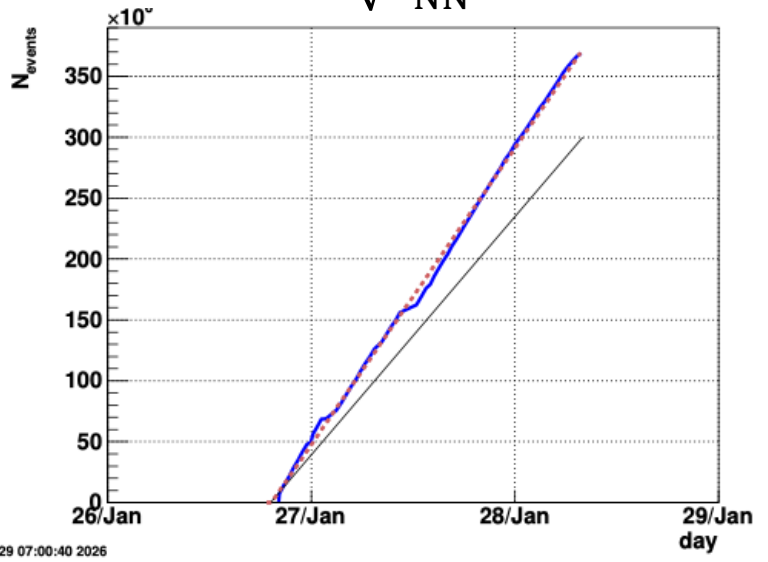

Thu Jan 29 07:00:40 2026

Run period 3: Oxygen-Oxygen collisions



Fill 36689

- A final opportunity to collect light-ion collisions was possible, and STAR collected O+O data at $\sqrt{s_{NN}} = 200$ GeV
- STAR previously collected O+O data in Run 21, the results from which have helped push interest in the system
- LHC also recently collided oxygen, the first time the same ions have been collided at RHIC and LHC
- Similar to Au+Au, the first three hours of each fill were high luminosity running before dropping to leveled low luminosity running for the following three hours

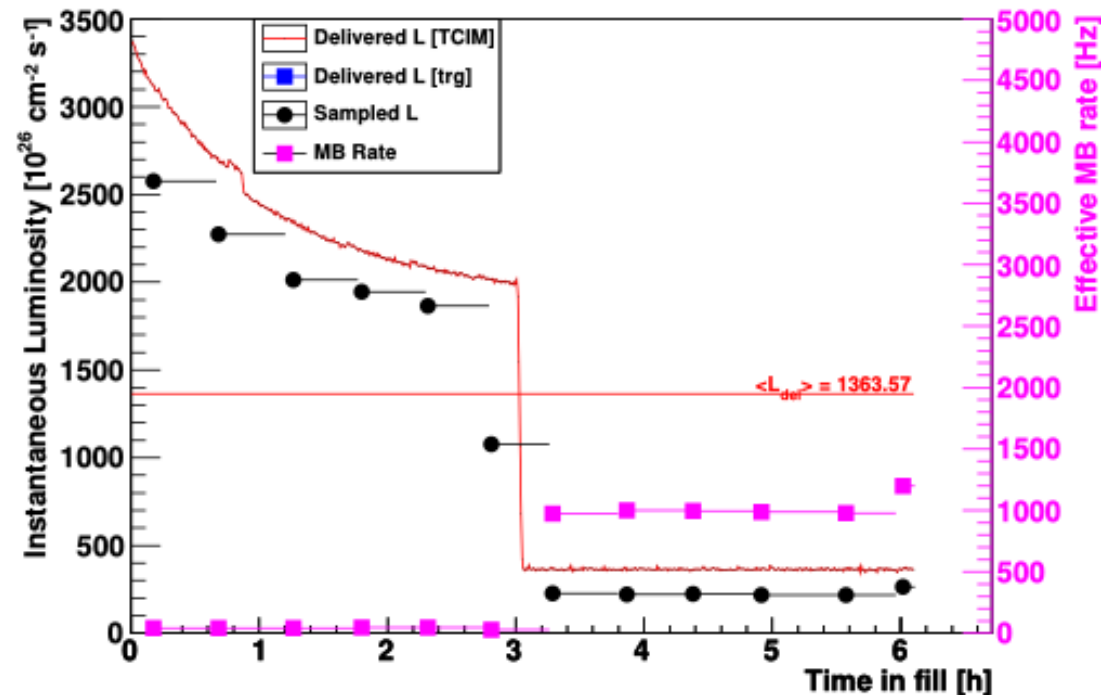

Leveling at 20 kHz ZDC after 3 hours

0+0 collisions data collisions



Delivered Luminosity [ub^{-1}]

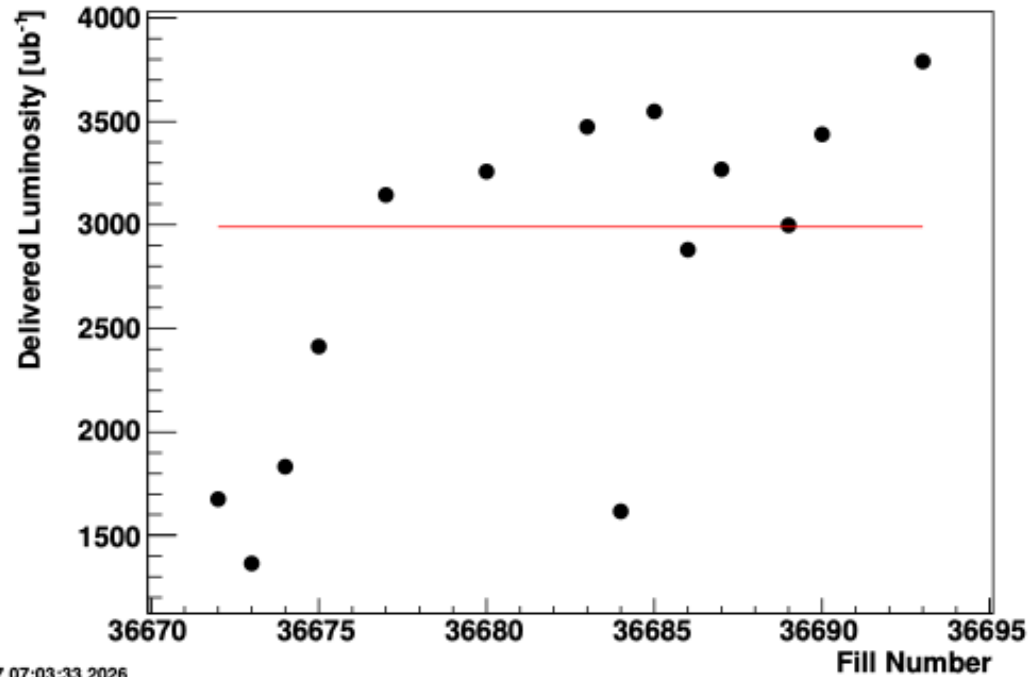

Sat Feb 7 07:03:33 2026

Fraction of Hours delivered while taking data

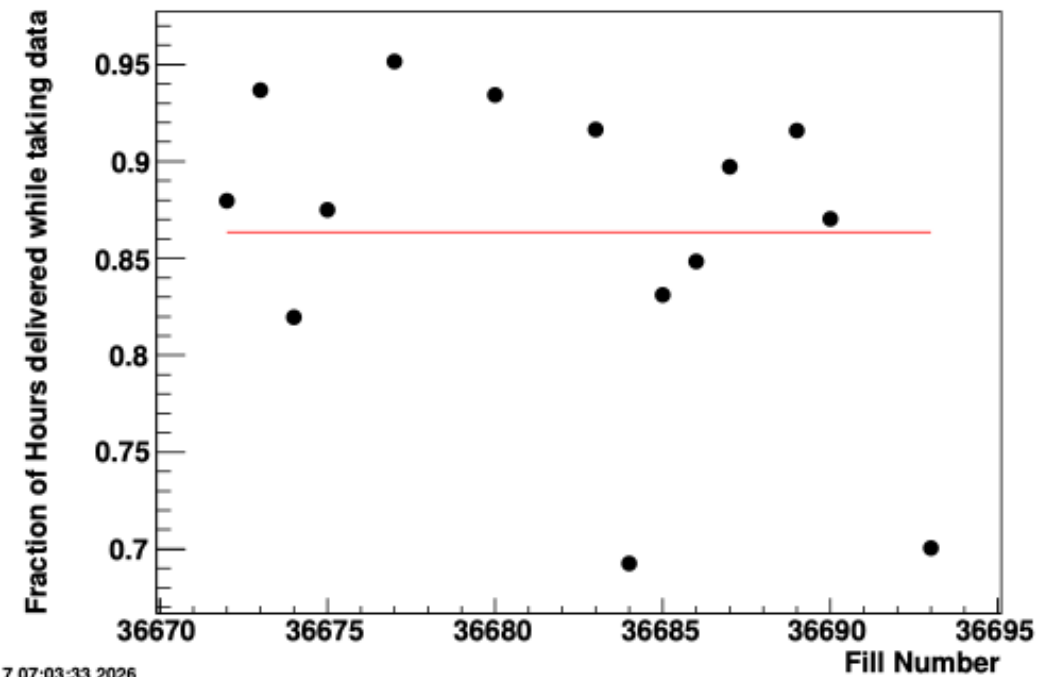

Sat Feb 7 07:03:33 2026

- RHIC delivered 0+0 from Feb. 1st through Feb. 6th
- 0.5 mrad crossing angle
- STAR collected data 86% of the time collisions were delivered

O+O Performance

- STAR and RHIC both ran excellently during the O+O run period!
- Supplemented the minimum bias and high multiplicity data collected in 2021
- Massively increased data for jets and heavy flavor analyses!

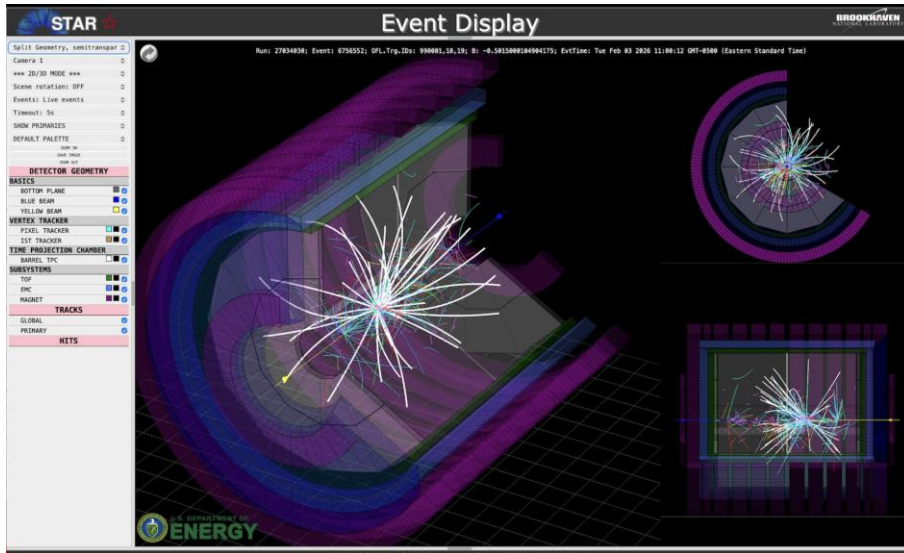

Minimum Bias Events

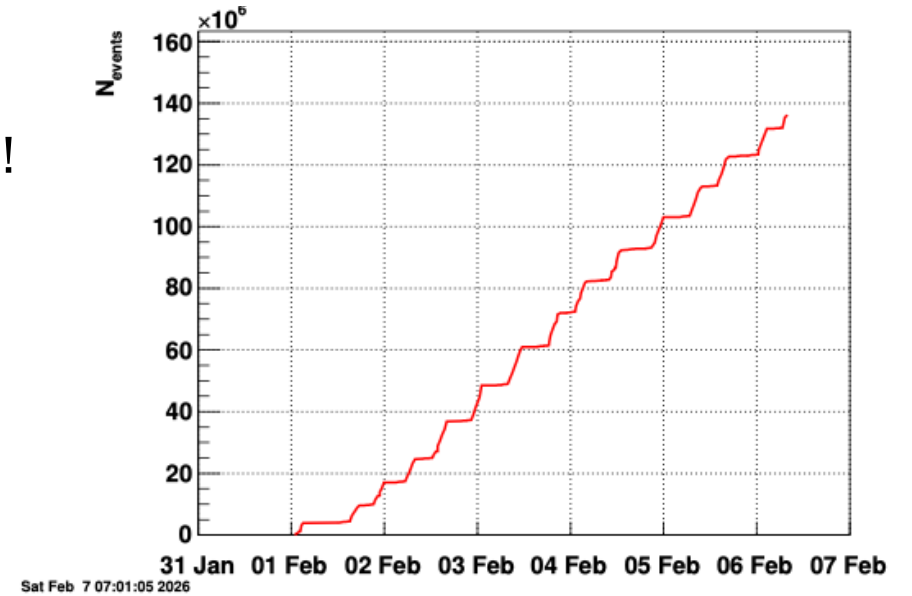

Sampled Luminosity

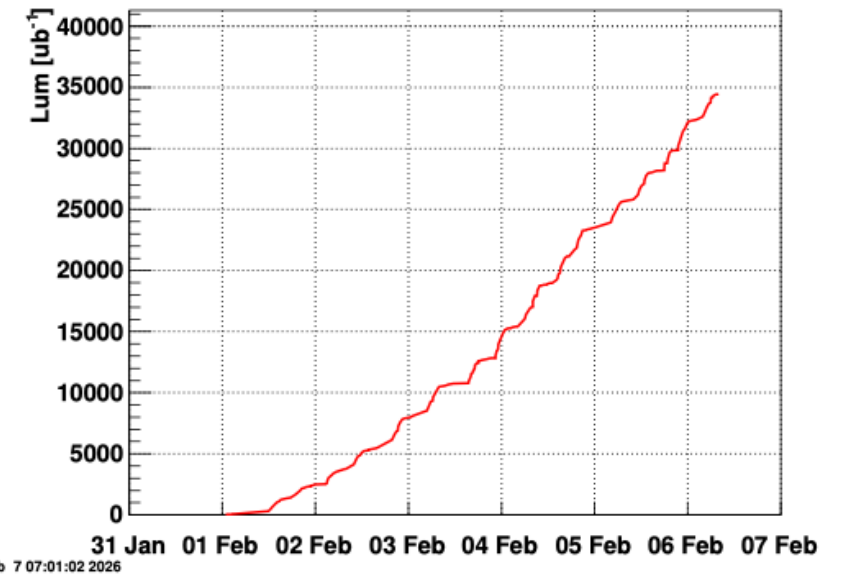

| Trigger | Run 21 | Run 25 |
|-------------------|----------------------|-----------------------|
| Min Bias | 402 million | 136 million |
| High multiplicity | 212 million | 266 million |
| BHT | 4.4 nb^{-1} | 34.4 nb^{-1} |

Nearly 8x increase!



Shifters and STAR operations team

- The efficient running of STAR requires the effort of the entire collaboration
- A STAR shift has
 - 1 shift leader
 - 2 detector operators
 - 1 shift crew member
 - A shift leader trainee and detector operator trainee may also be present
- In Run 25, we had
 - 46 weeks of shift
 - 653 shifts taken
 - 267 unique shifters
 - 18 period coordinators
 - 33 on-call experts
- Special thanks to JH Lee for serving as the STAR run coordinator!

Final collisions



- 25 years, 7 months, and 25 days after recording its first collision, STAR recorded its final collision

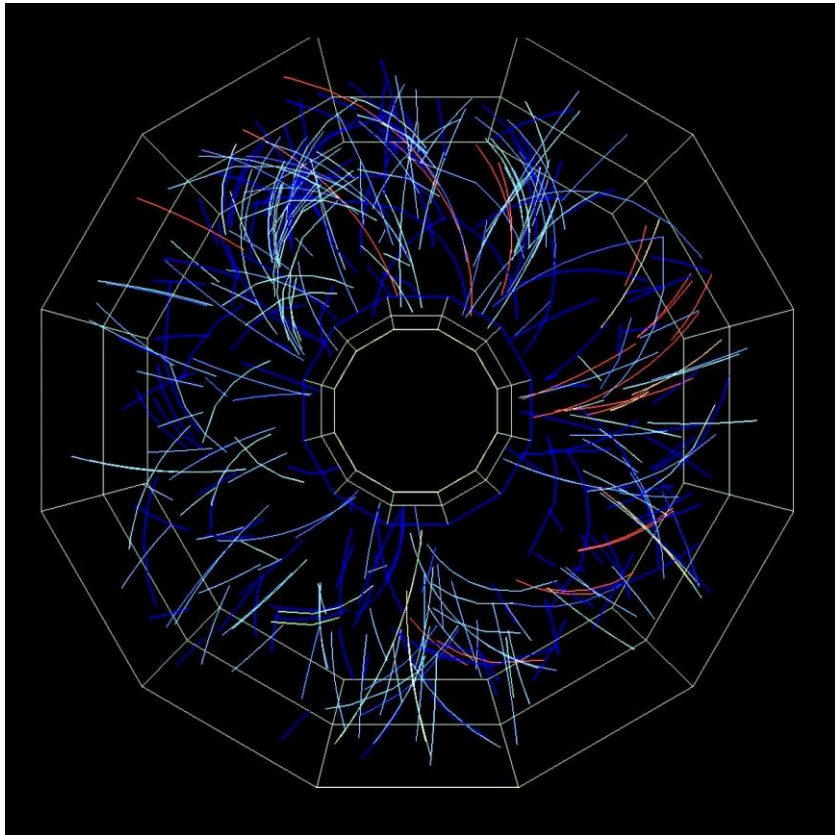

- The final 0+0 collision occurred February 6th, 2026, shortly after 9 AM
- We had a crowded control room, including many who had been there from the start of STAR



Legacy

- STAR has already had a significant impact on our understanding of QCD
- The large Au+Au and p+p datasets collected in Runs 23-25 will ensure STAR remains productive scientifically well into the future!
- Over 25 runs, data was collected for pp, pAl, pAu, dAu, He3Au, OO, CuCu, CuAu, ZrZr, RuRu, AuAu, and UU systems
- Au+Au collisions at a wide range of energies in both a fixed target and collider mode
- Several generations of scientists have had the privilege to work with STAR while it was collecting data, and the excellent datasets on tape ensure several more will utilize its data
 - 420 PhD thesis on STAR data so far!

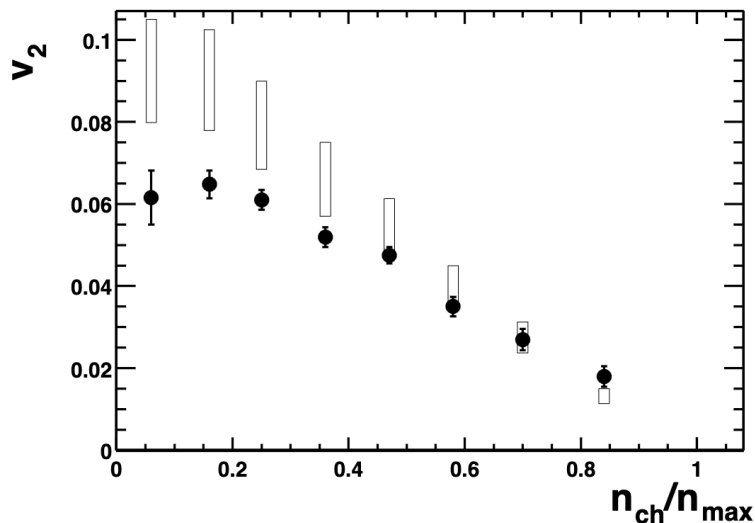

First STAR Publication
October 2001

STAR, *Phys. Rev. Lett.* **86** (2001) 402

Most recent STAR publication
May 2026

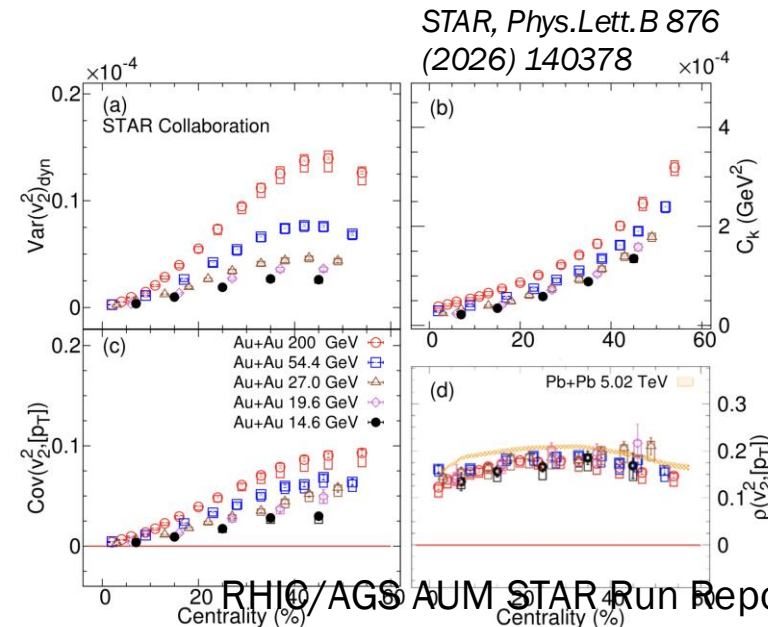

STAR, *Phys.Lett.B* 876
(2026) 140378

RHIC/AGS AUM STAR Run Report

Conclusions



- STAR concluded its operations with an excellent Run 25!
- Completed the collection of a large Au+Au dataset for future analyses
- Filled in the crucial energy range in the search for a QCD critical point
- Expanded STARs collection of light ion collision data, particularly for jets and heavy flavor physics
- Thank you to everyone involved in the successful operation of STAR and RHIC in Run 25!

First STAR collaboration meeting

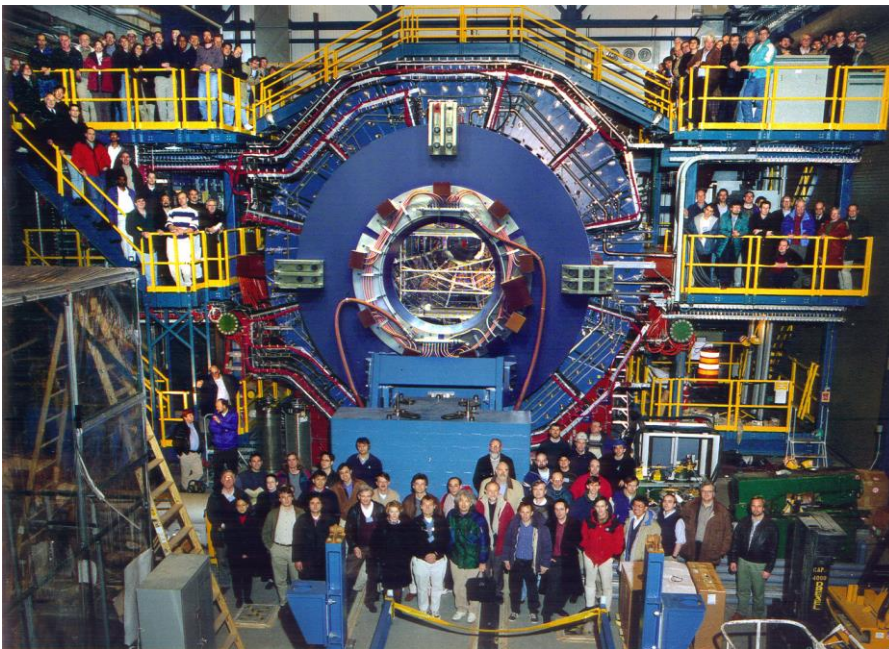

2026 STAR collaboration meeting

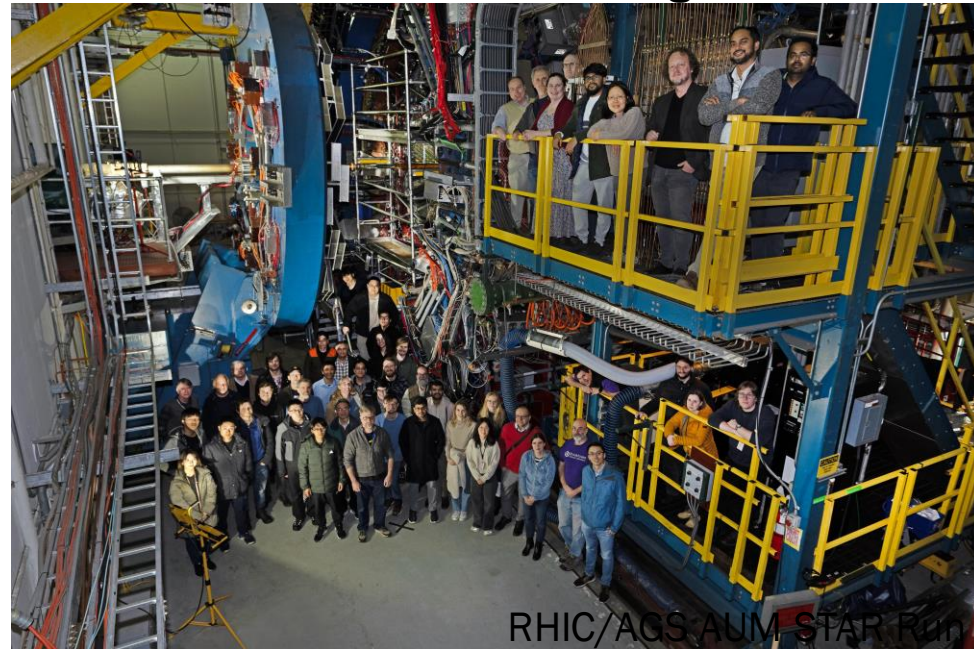

Backup

STAR detector

