

# Measurement of Charged Hadron Multiplicity in Au+Au Collisions at $\sqrt{s_{NN}} = 200$ GeV with the sPHENIX Detector

[JHEP 08 (2025) 075]

Cheng-Wei Shih for the sPHENIX Collaboration  
National Central University & RIKEN

[Poster #9]

2026 RHIC/AGS ANNUAL USERS' MEETING, May 13th, 2026

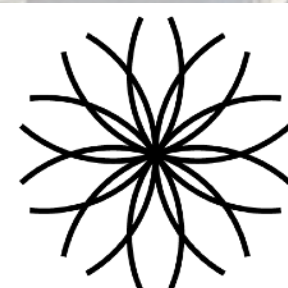

**CHIP**  
CENTER FOR HIGH ENERGY  
AND HIGH FIELD PHYSICS



國立中央大學  
National Central University



Brookhaven  
National Laboratory

- Trace total entropy production and provide constraints on initial conditions, and subsequent evolution of the QCD medium
- Measurement primarily based on INTT: **tracking-based standard-candle measurement for sPHENIX**
- Measurement using Au+Au collision data taken in zero field  
→ Charged particles flying undeflected, leading to minimal angular separation in the signal tracklet

## Intermediate Silicon Tracker (INTT)

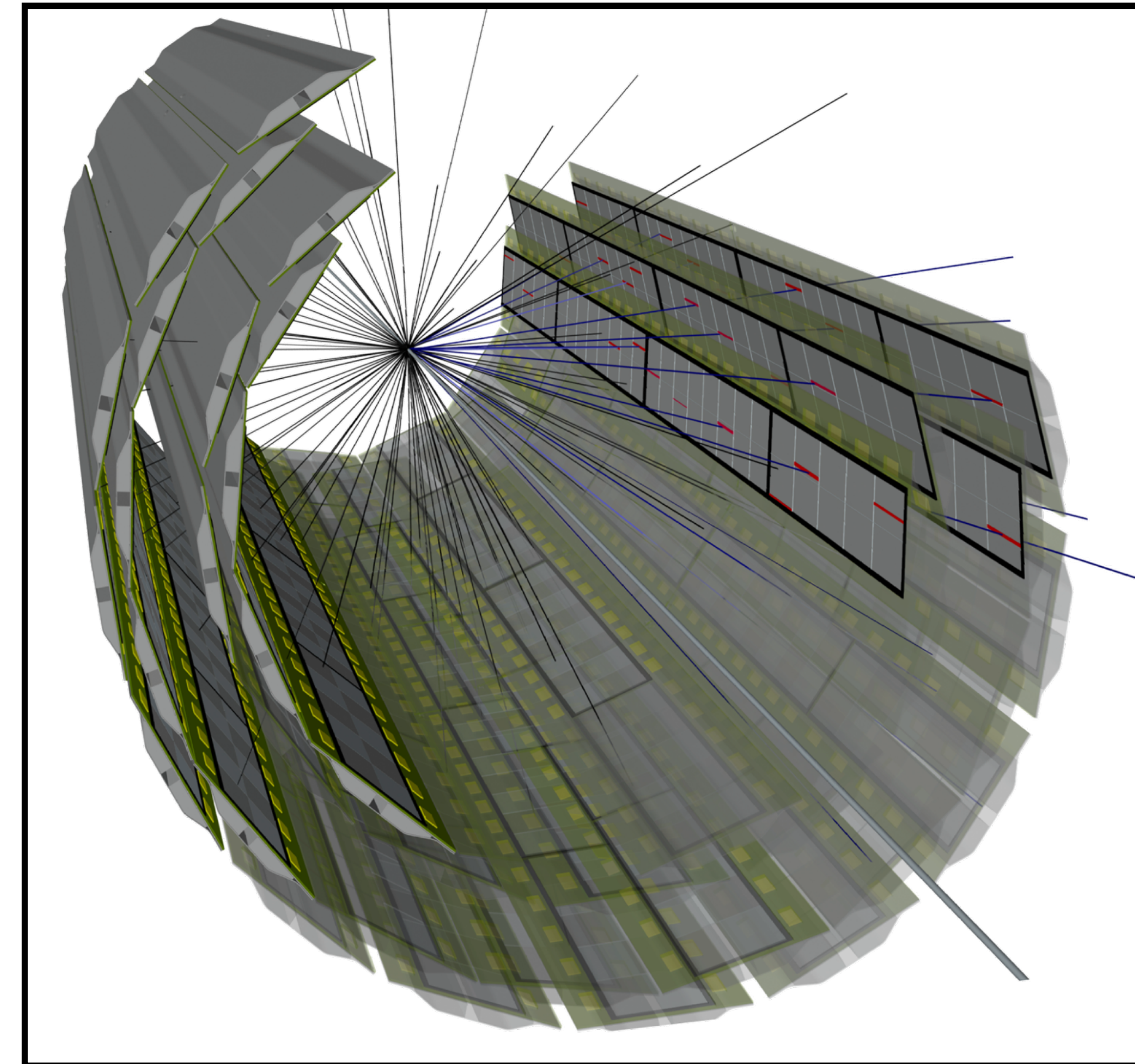

# Intermediate Silicon Tracker, INTT

## INTT: two-layer barrel silicon strip tracker

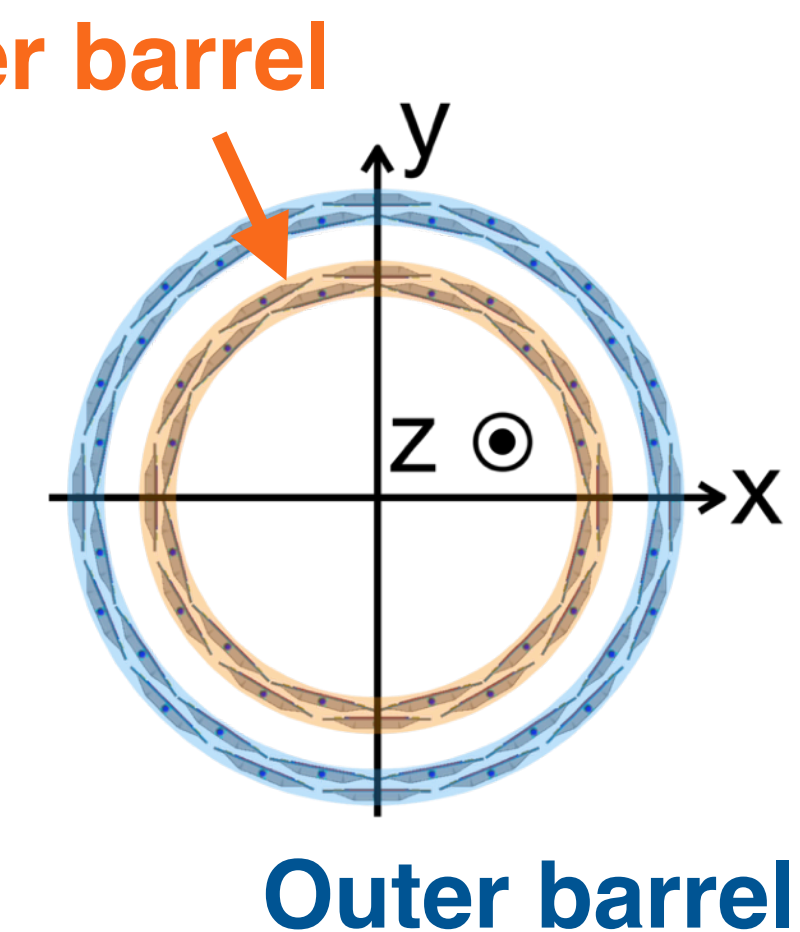
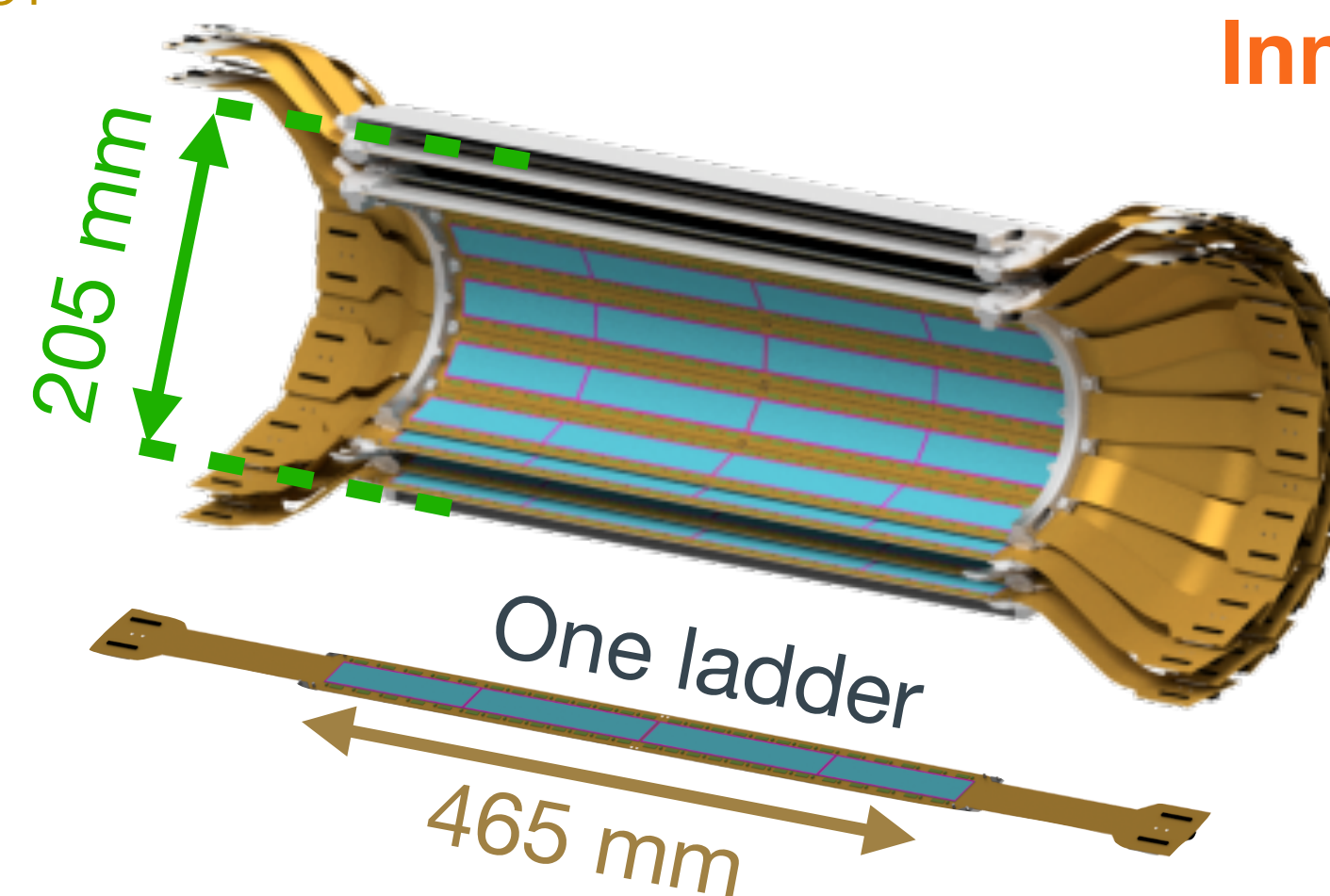
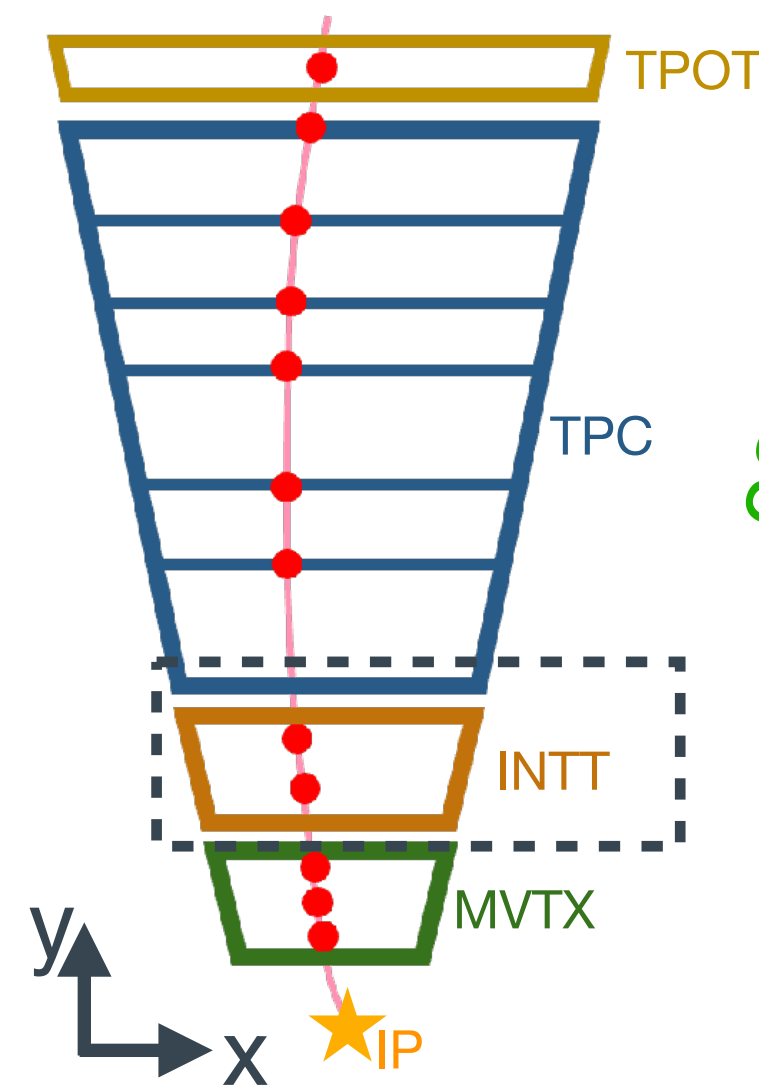
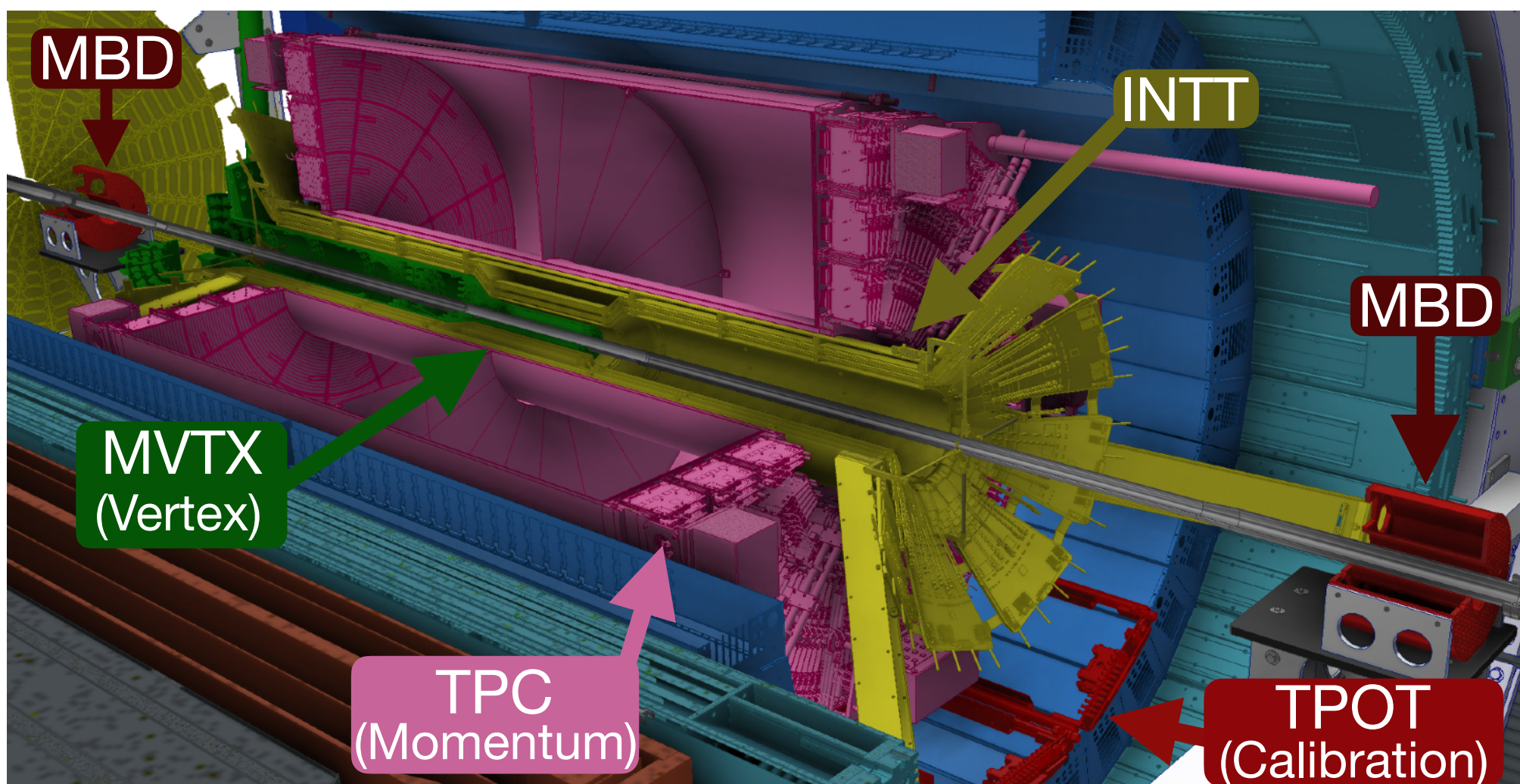

### INTT specification

Radiation length	1.14% $X_0$ per ladder
Strip pitch	78 $\mu\text{m}$
Strip length	16 or 20 mm
Full azimuthal coverage	
$ \eta  < 1.1$ for $ z_{\text{vtx}}  \leq 10$ cm	

- Strip pitch 78  $\mu\text{m}$   $\rightarrow$  Excellent spatial resolution in  $\phi$  angle
- Two-layer barrel strip tracker between the MVTX and TPC  $\rightarrow$  Bridge tracks of the MVTX and TPC
- Timing resolution better than the RHIC crossing frequency  $\rightarrow$  Associate reco. tracks with RHIC bunch crossings

# Hardware preparation for INTT

- I have been dedicated to the sPHENIX experiment working on INTT for over 7 years (since May 2019)
- I am grateful to start my research career by realizing a new particle detector from scratch, spanning the INTT ladder assembly, INTT barrel construction, software preparation, etc

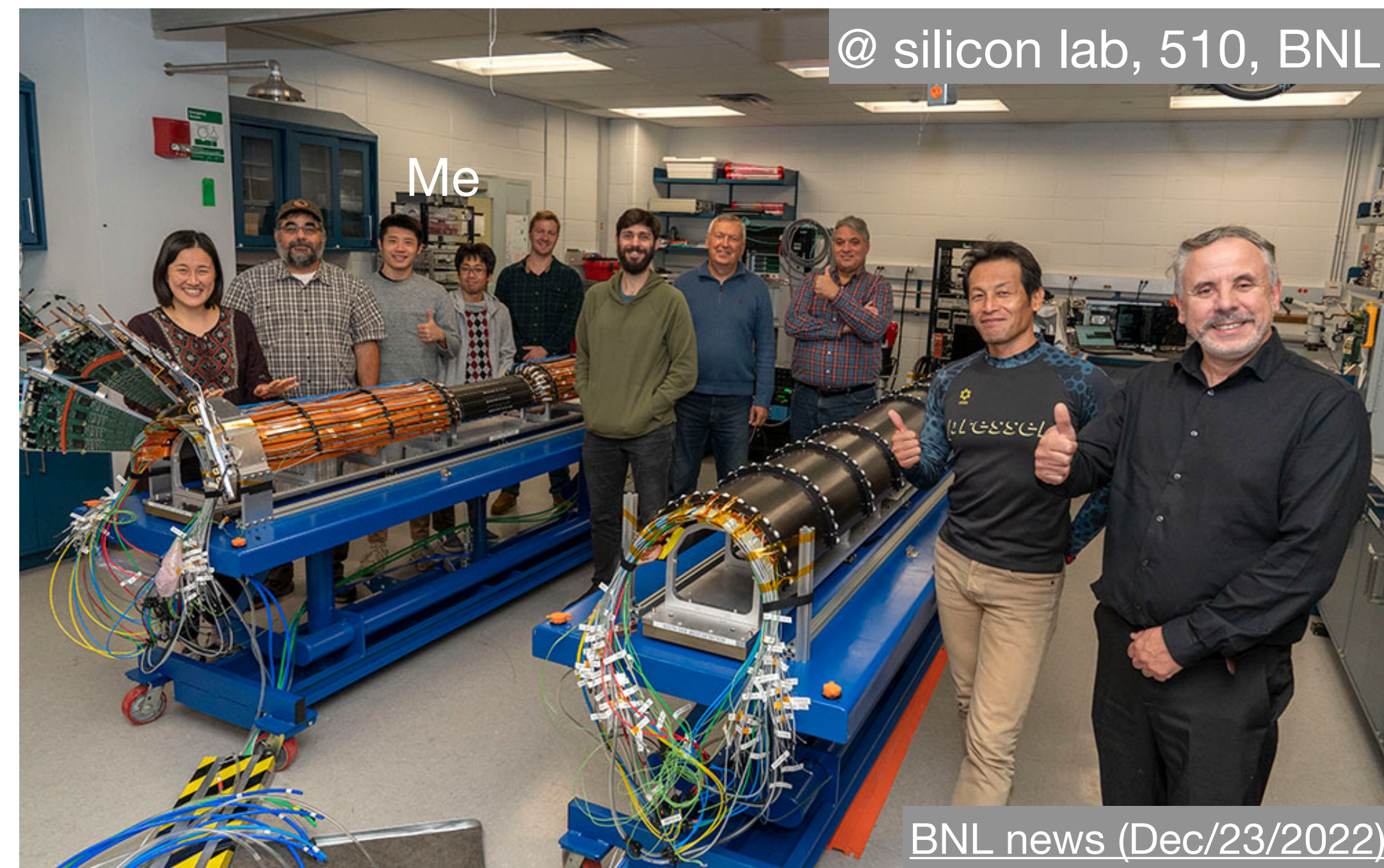
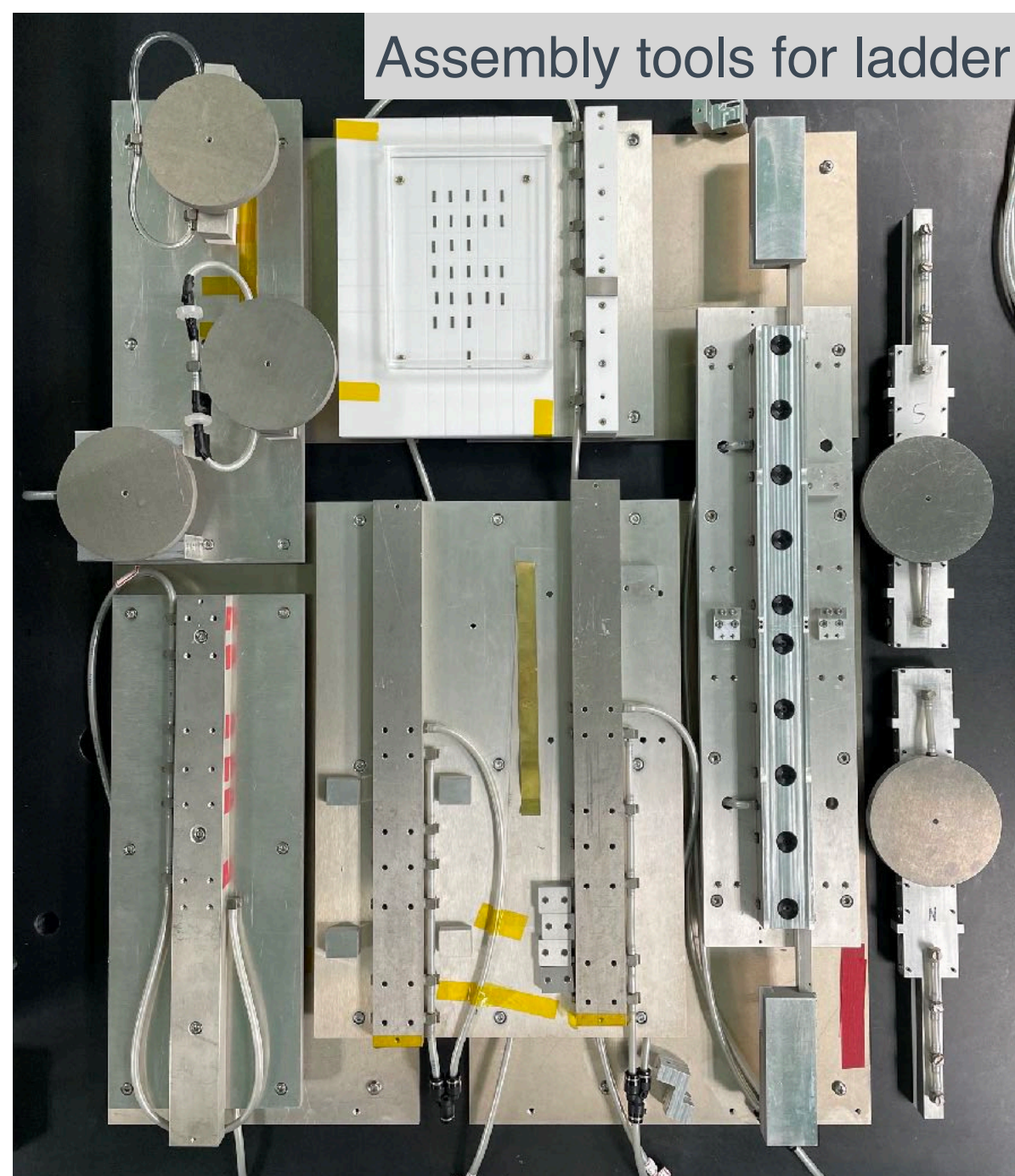

[\[Ladder assembly video \(2 min\)\]](#)

A test beam experiment was conducted at RARiS, Japan, to evaluate the performance of INTT

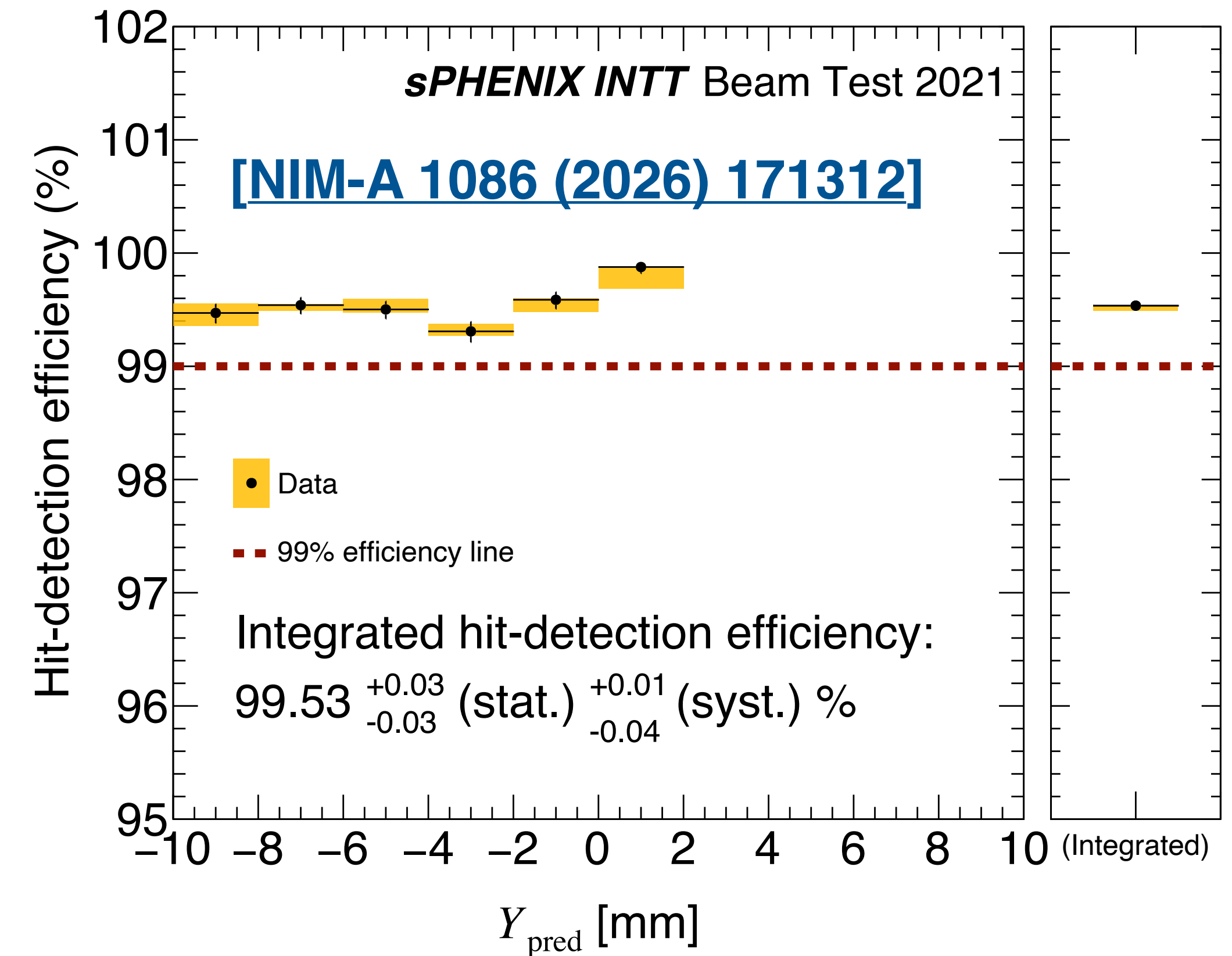
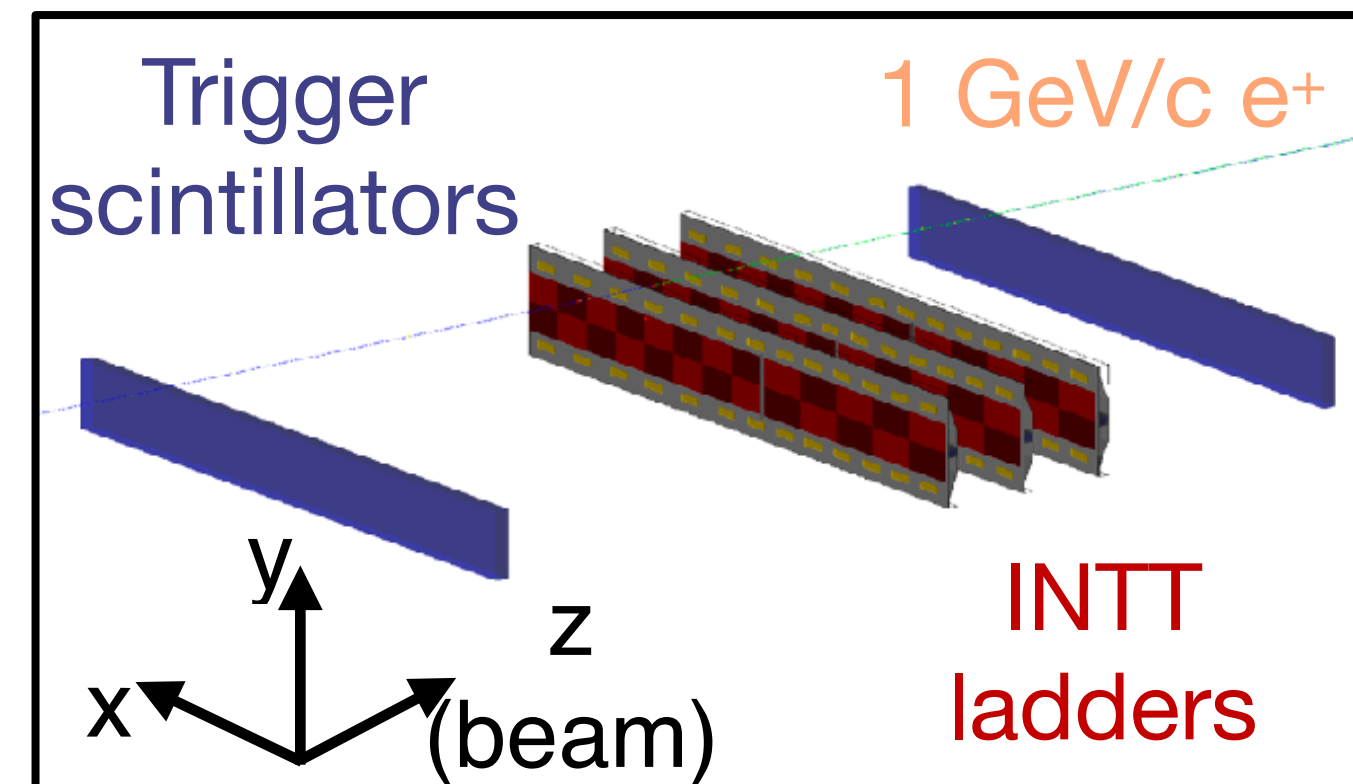
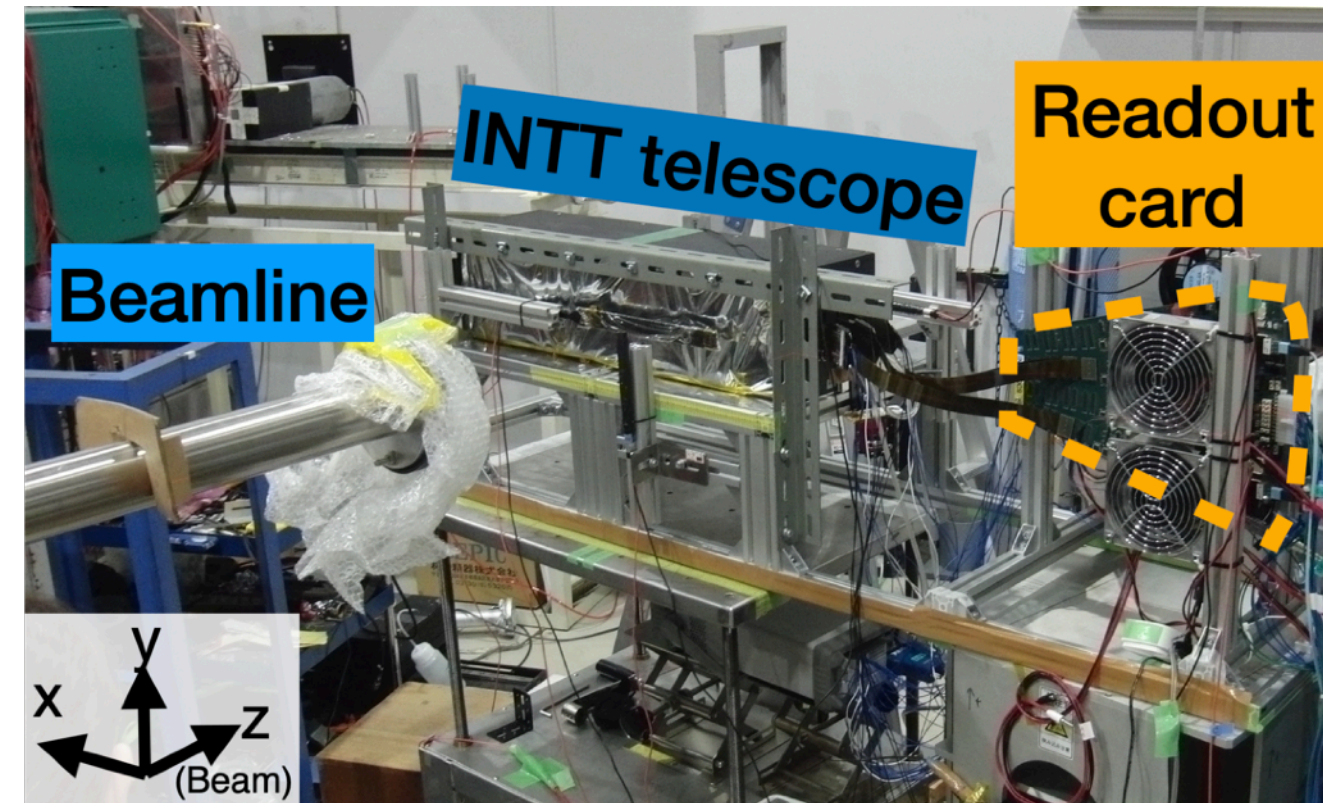

- INTT meets all operational requirements
- **Hit-detection efficiency:**  $99.53^{+0.03}_{-0.03}$  (stat.)  $^{+0.01}_{-0.04}$  (syst.) %
- Published in [C.W. Shih et al. NIM-A 1086 \(2026\) 171312](#)

**Hit-detection efficiency of INTT over 99%, supporting the sPHENIX tracking program**

# Detector performance in Au+Au collisions

The sPHENIX detector started its commissioning with Au+Au collisions in May 2023

## MBD charge sum v.s. INTT # of clusters

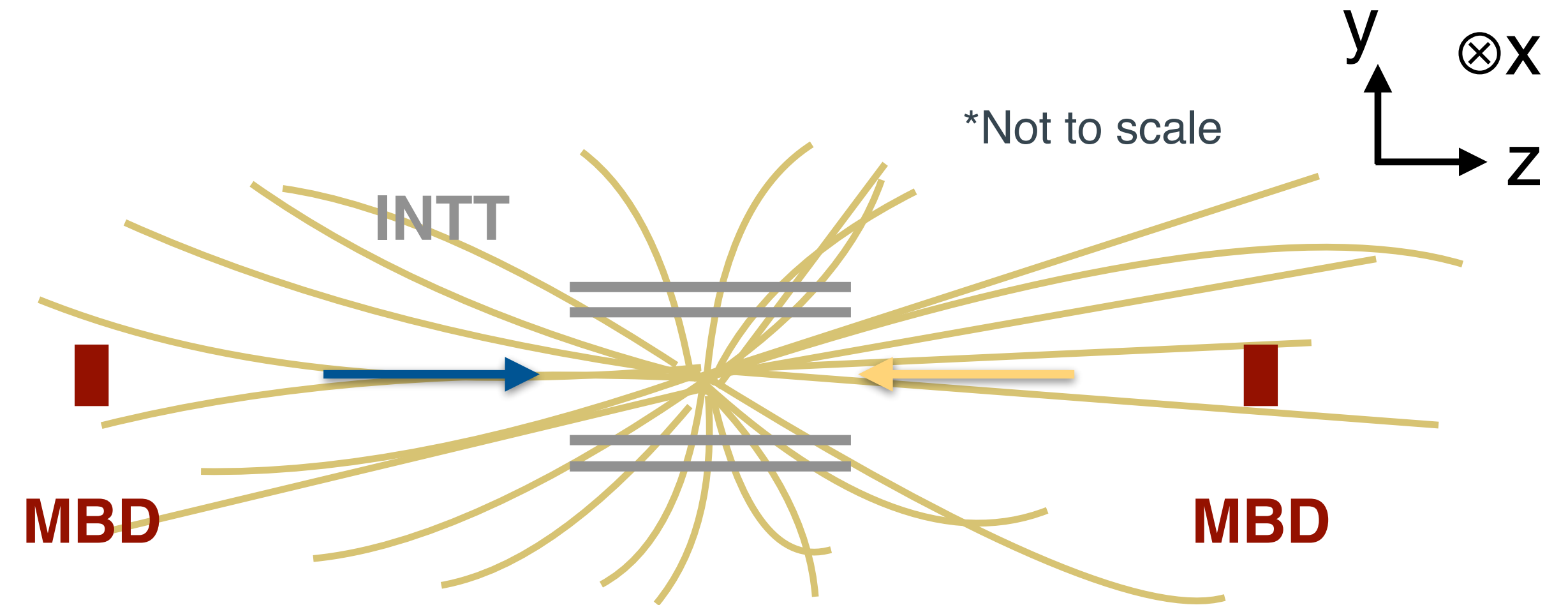
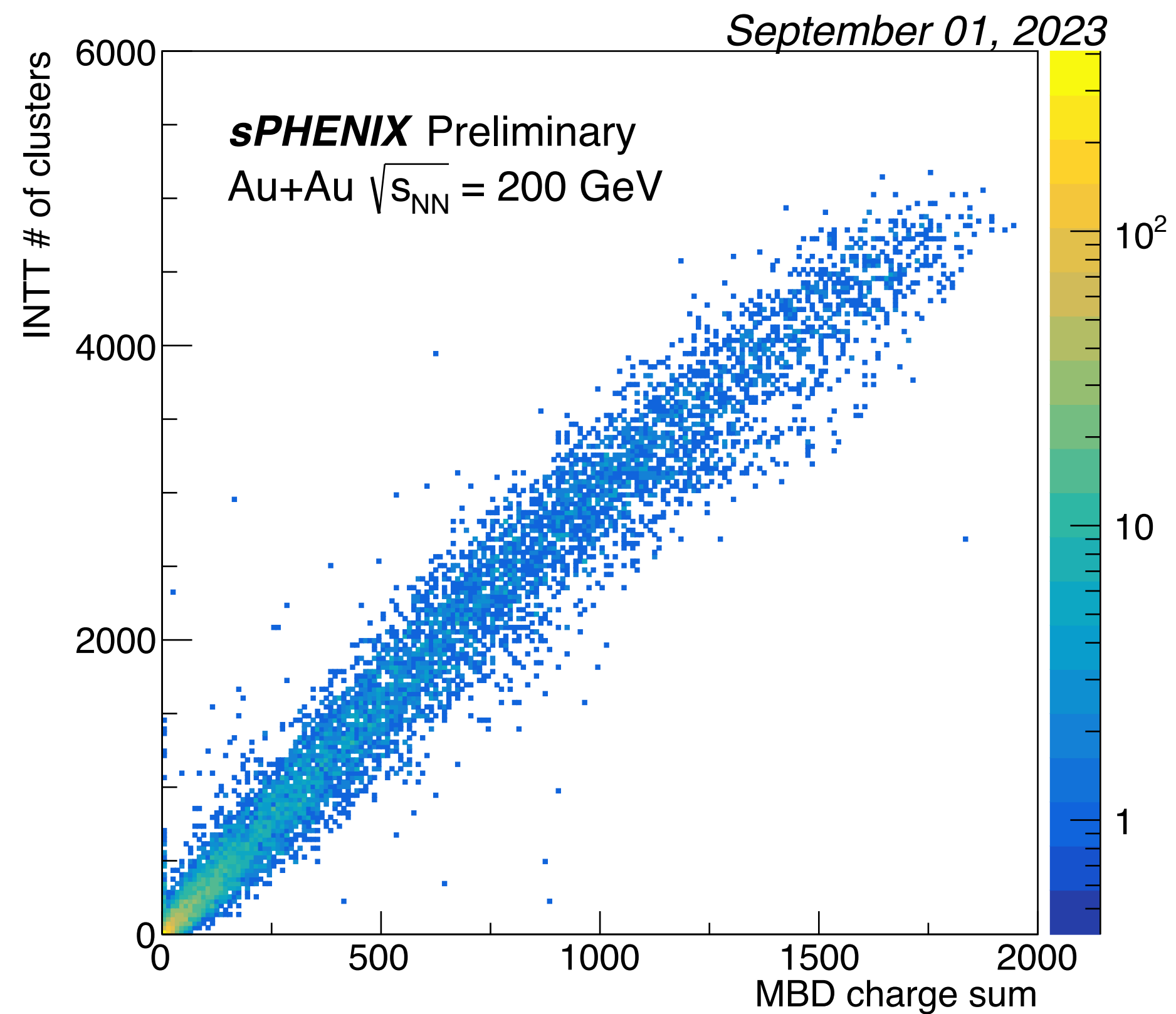

Clear positive correlation observed:

- Real signal
- Systems synchronized
- Systems working well

MBD charge: MBD energy deposition calibrated such that one MIP is set at unity

- INTT, a two-layer barrel strip tracker, is **NOT** designed for reconstructing collision vertices
- Unique method developed to enable z-vertex reconstruction by INTT
  - Stacking possible z-vertex ranges given by INTT cluster pairs (one inner and one outer cluster)

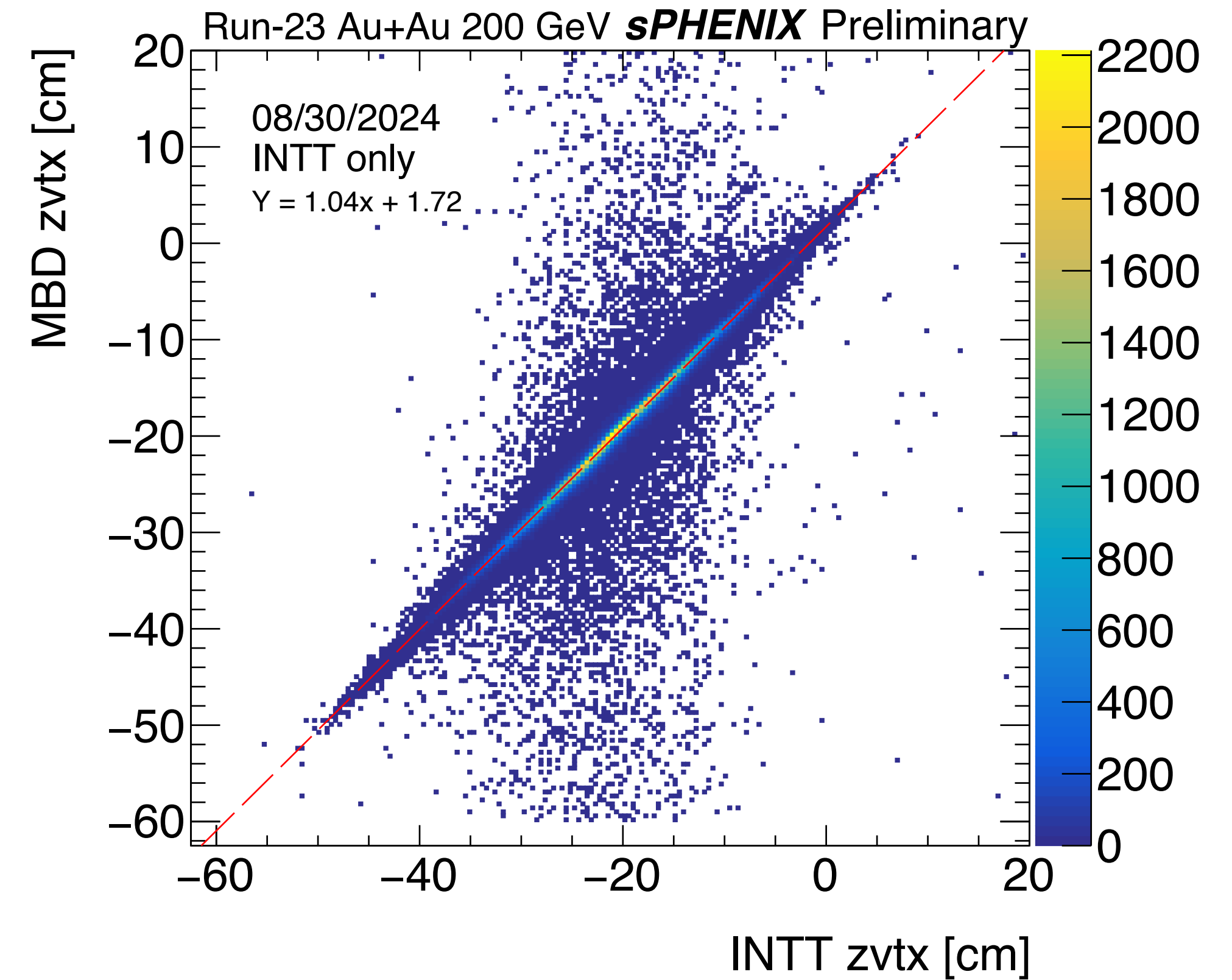
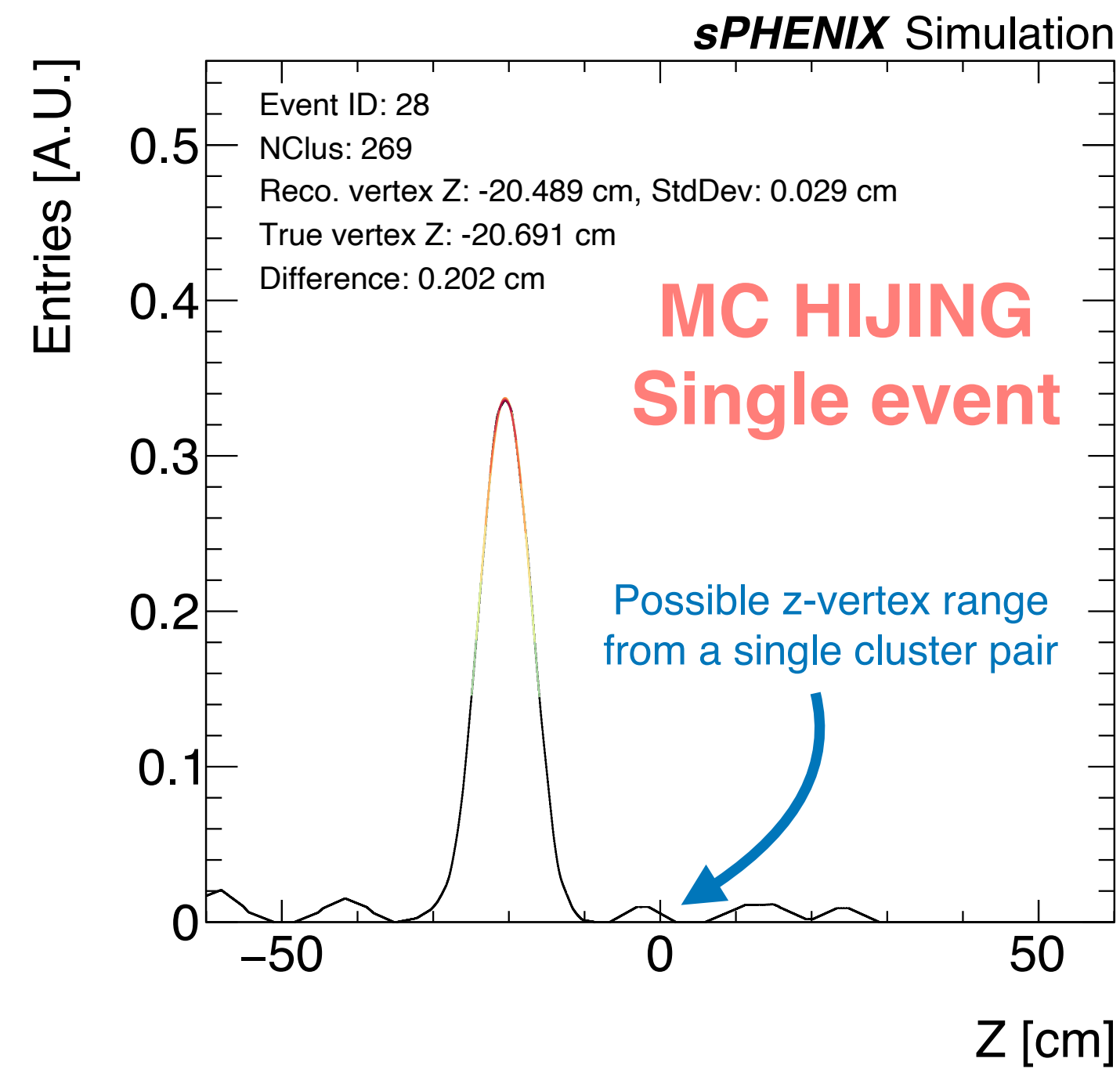
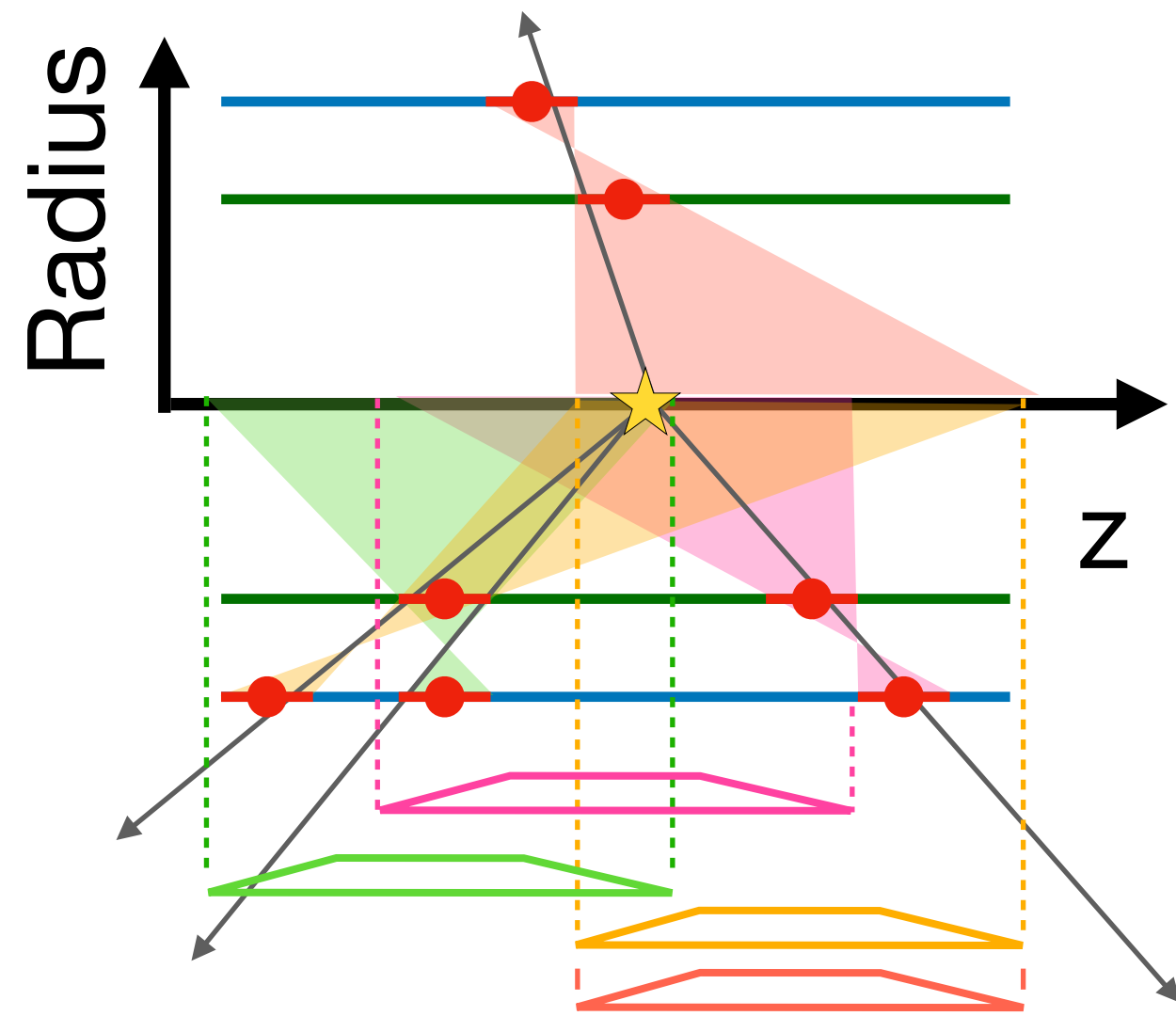

**Clear positive correlation identified, with the slope close to unity**  
**The foundation of the  $dN_{ch}/d\eta$  measurement by INTT**

# Event centrality in Au+Au collisions

Event centrality is characterized by the sPHENIX Minimum Bias Detector (MBD)

MBD:

Three concentric rings of PMTs located in the forward region

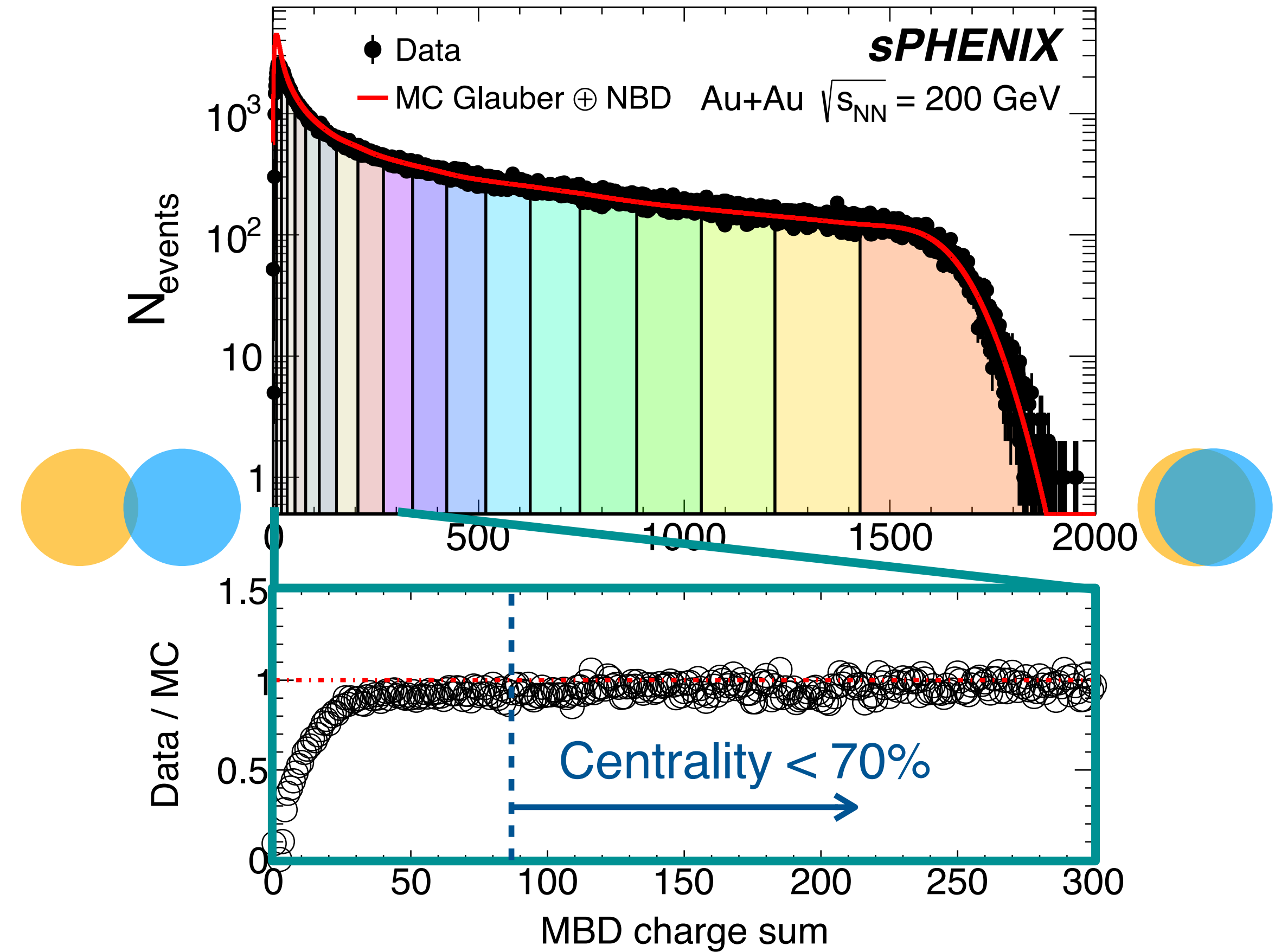
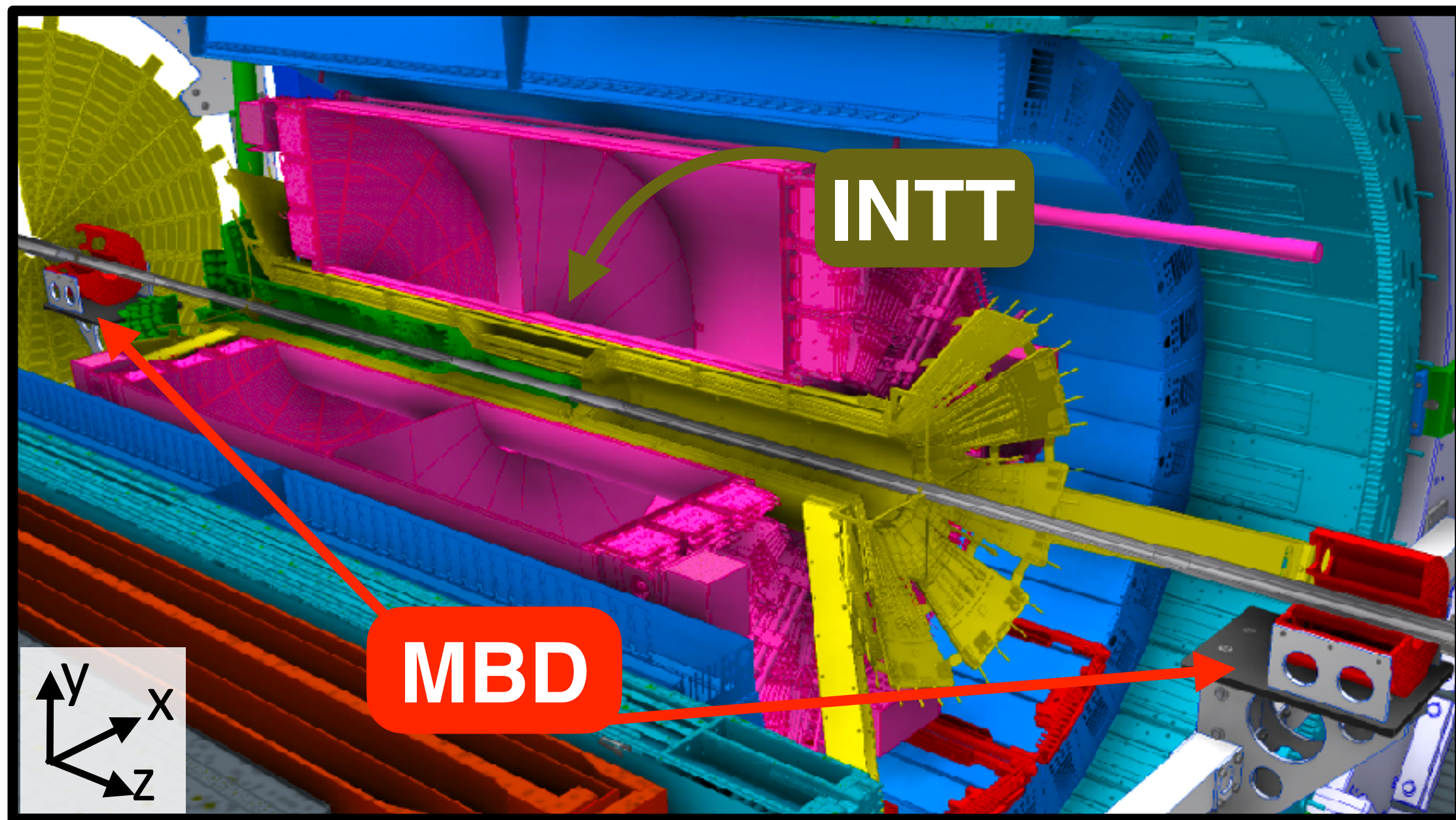

MBD charge: MBD energy deposition calibrated such that one MIP is set at unity

**Minimum-Bias trigger is fully efficient in 0-70% centrality range  $\rightarrow$  no trigger bias**

# $dN_{ch}/d\eta$ extracted by counting INTT cluster pairs

sPHENIX Final! - [JHEP 08 (2025), 075]

- Combinatoric method:

- Populating all possible INTT cluster pairs (one inner + one outer cluster)
- Combinatorial background: Same pairing procedure after rotating the inner-barrel clusters by  $\pi$  in  $\phi$

- The closest-match method:

- Counting the smallest angular-separation ( $\Delta R$ ) cluster pairs

- Corrections are applied to account for detector acceptance, reconstruction efficiency, etc

$$\Delta\phi = \phi_{\text{inner}} - \phi_{\text{outer}}$$

$$\Delta\eta = \eta_{\text{inner}} - \eta_{\text{outer}}$$

$$\Delta R = \sqrt{(\Delta\eta)^2 + (\Delta\phi)^2}$$

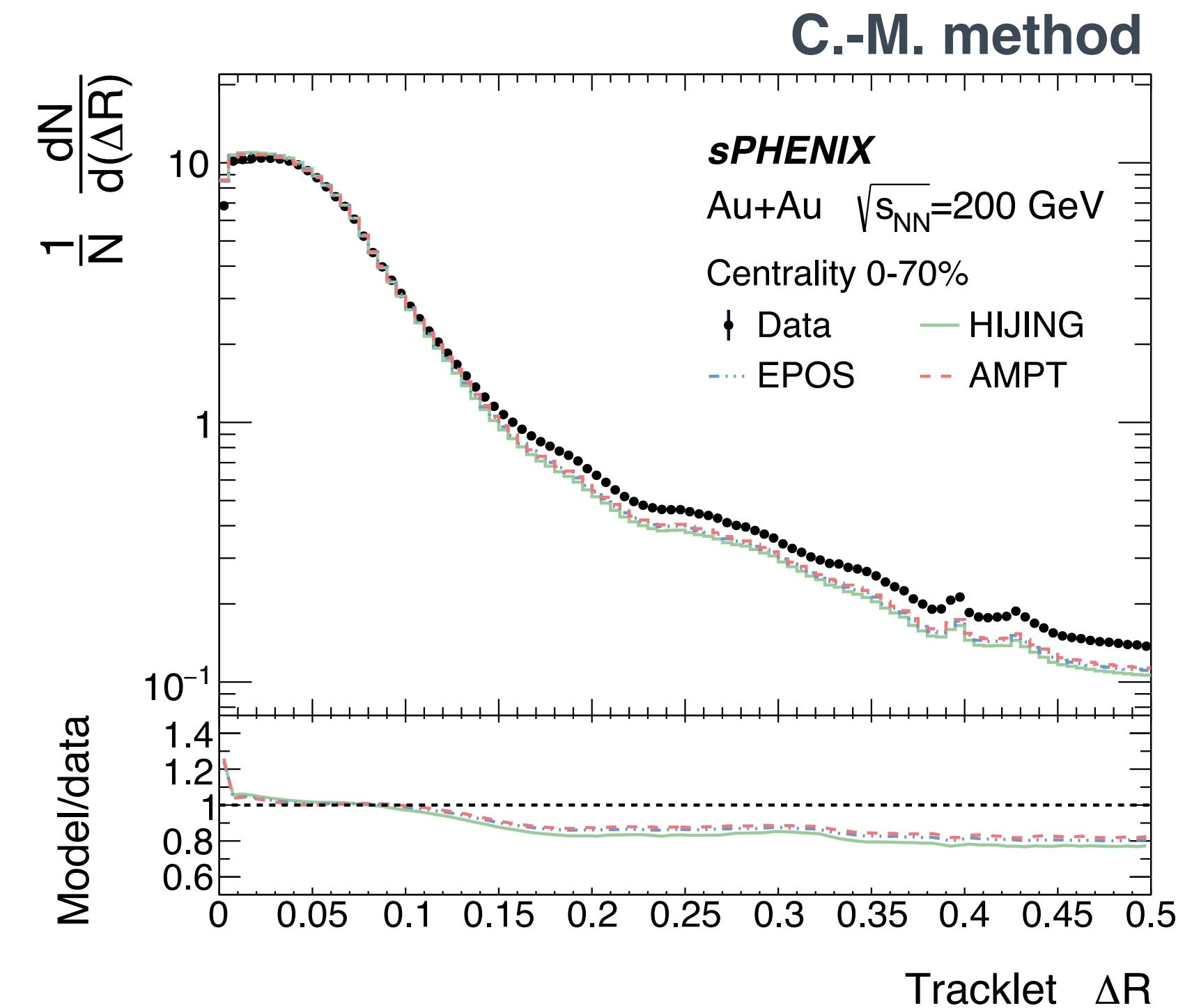
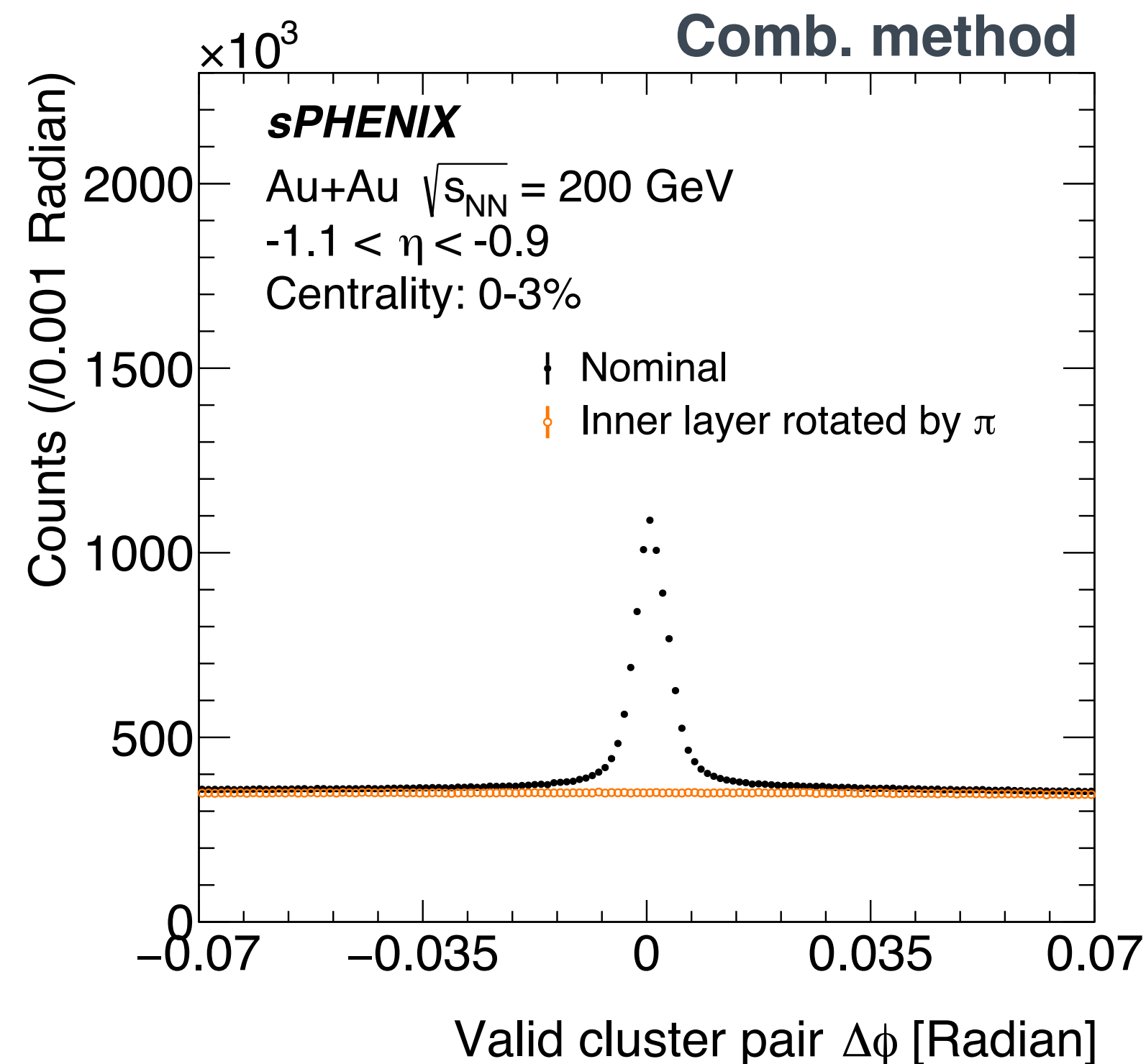
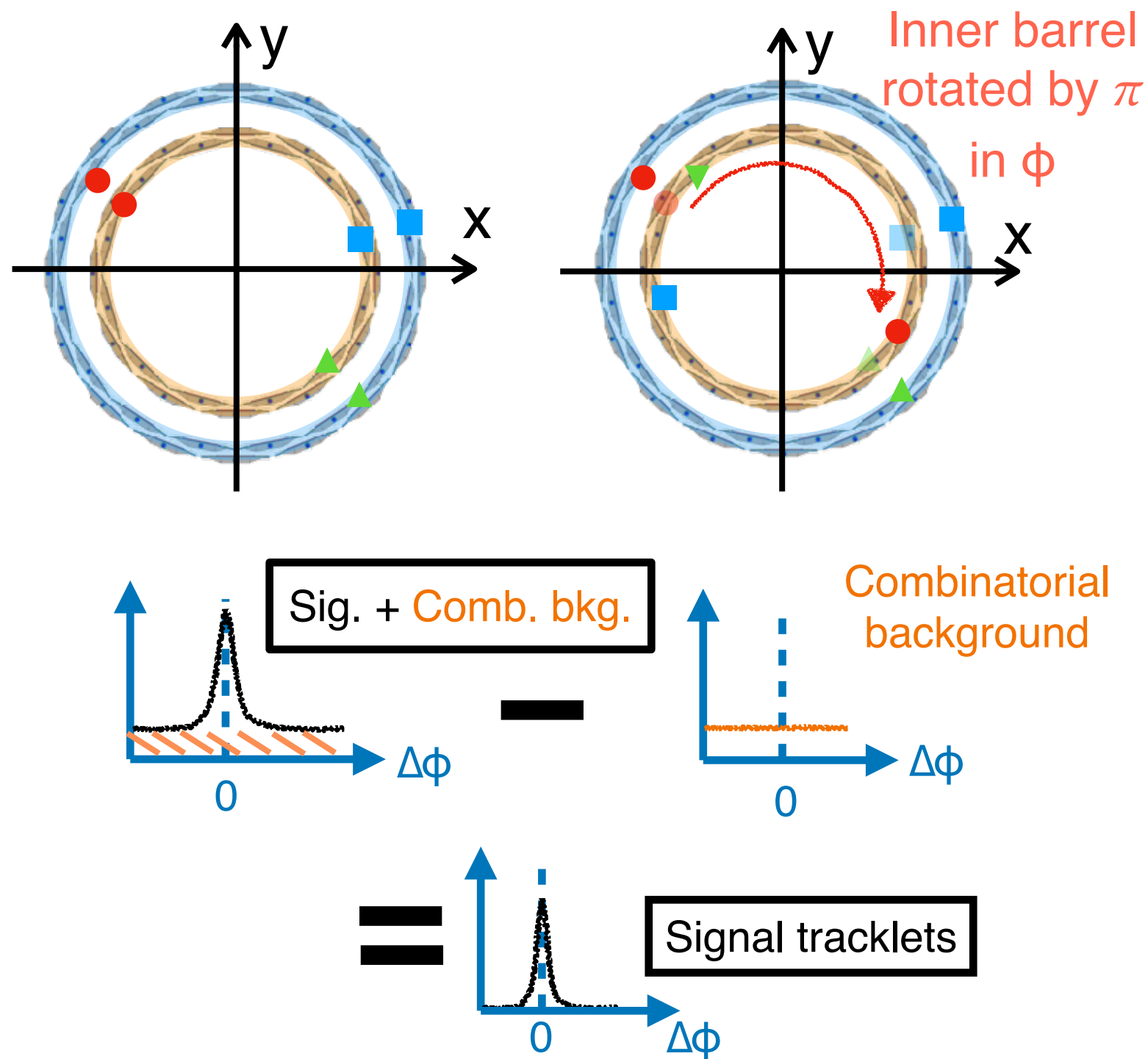

# sPHENIX $dN_{ch}/d\eta$ in Au+Au collisions

sPHENIX Final! - [JHEP 08 (2025), 075]

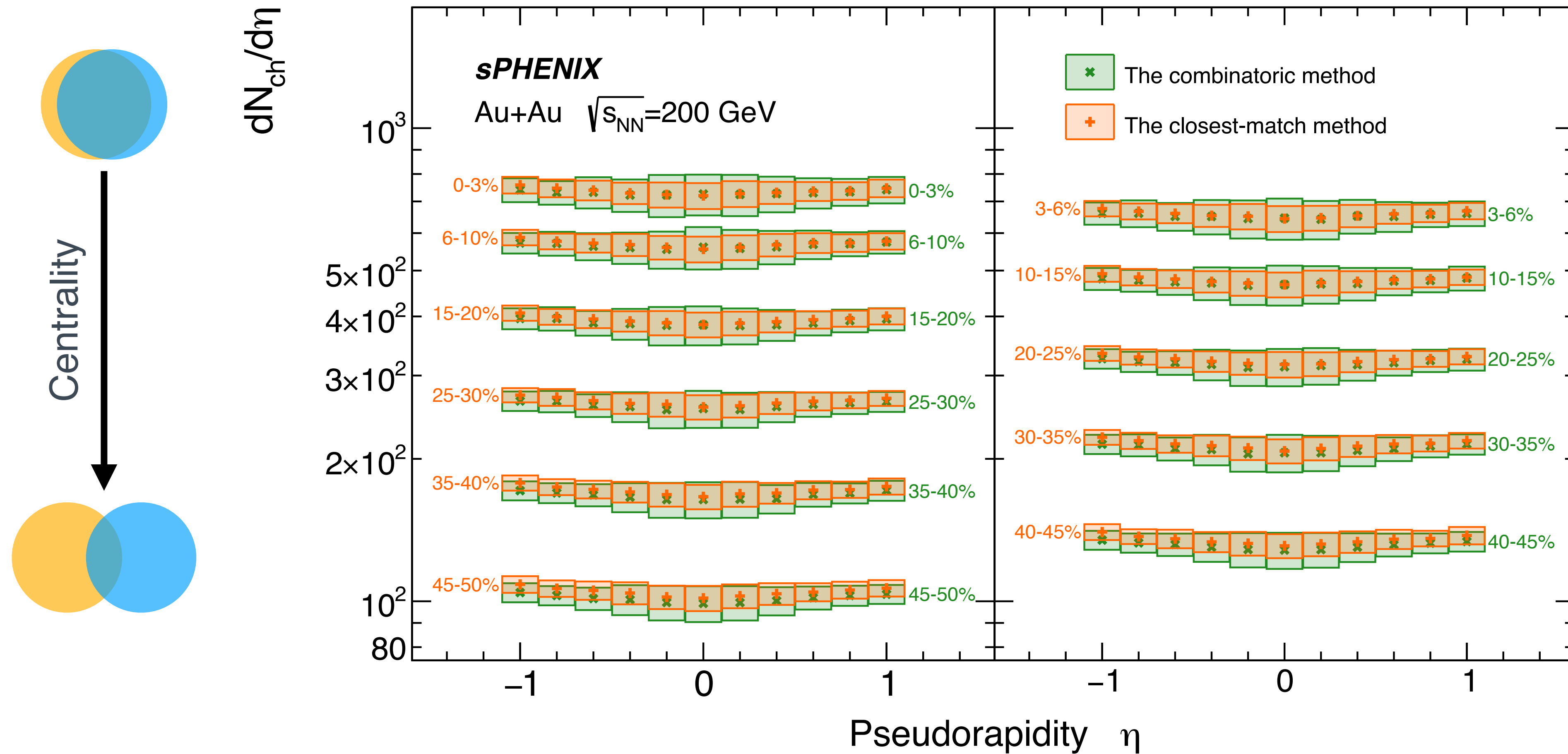

Results from two analysis methods are consistent with each other, and are combined

# sPHENIX $dN_{ch}/d\eta$ in Au+Au collisions



sPHENIX Final! - [JHEP 08 (2025), 075]

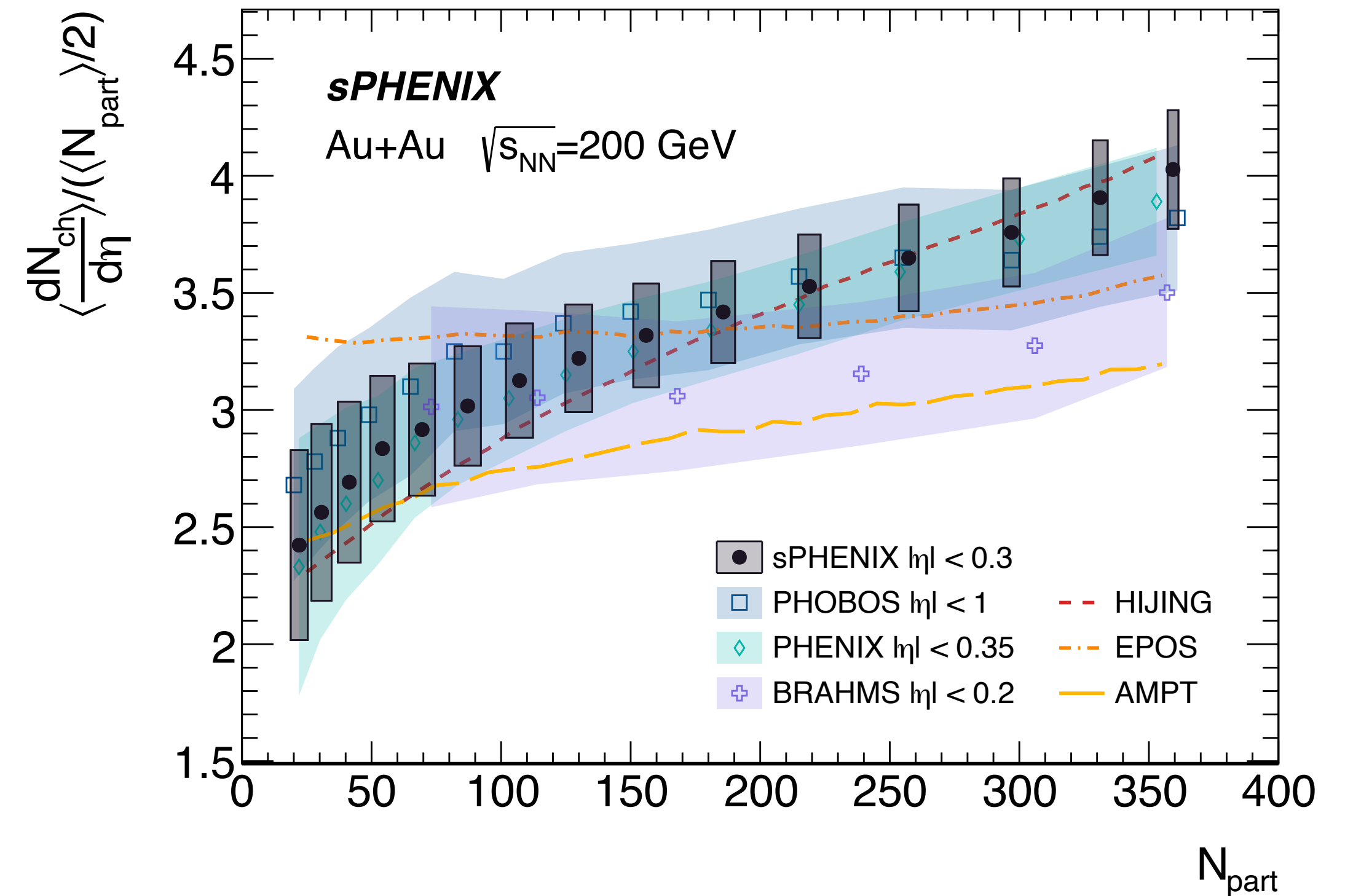
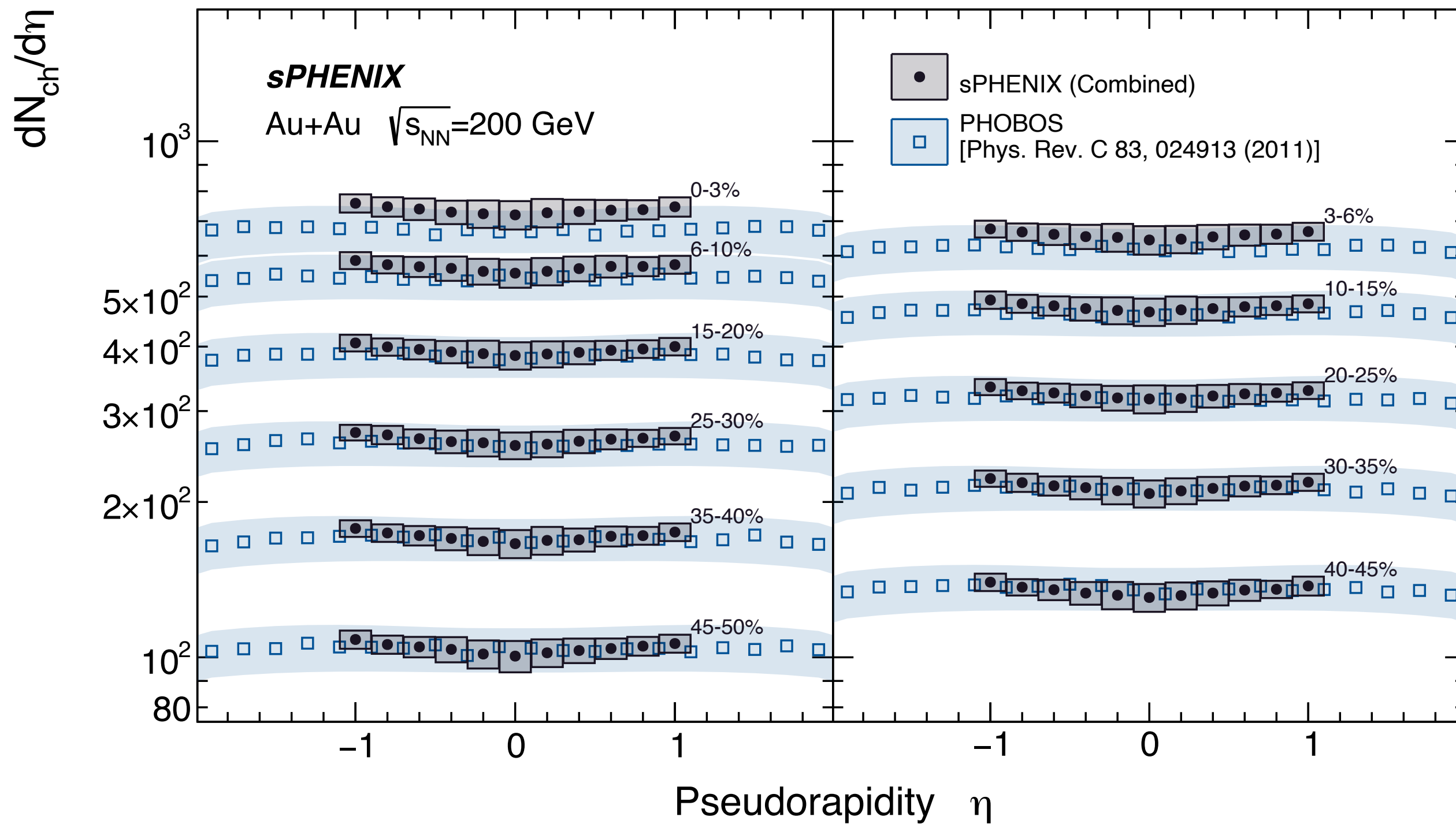

- sPHENIX final  $dN_{ch}/d\eta$  v.s.  $\eta$  consistent with the PHOBOS results across various centrality classes and  $\eta$  bins with improved uncertainties
- Mid-rapidity  $dN_{ch}/d\eta$  per participant pair as a function of  $N_{part}$ 
  - Consistent with all previous RHIC results and offer improved uncertainties in mid-centrality events
  - Best described by the HIJING model

- Charged hadron multiplicity ( $dN_{ch}/d\eta$ ) is a critical bulk observable that traces total entropy production and serves as a tracking-based standard-candle measurement for sPHENIX
- The Intermediate Silicon Tracker, INTT, is a newly built two-layer barrel silicon strip tracker for sPHENIX that bridges tracks of the MVTX and TPC, and associates reconstructed tracks with the corresponding RHIC bunch crossings
- The sPHENIX  $dN_{ch}/d\eta$  results, extracted using INTT, agree with previous RHIC measurements and offer improved uncertainties in  $\eta$  bins and in the mid-centrality events
- I have been privileged to start my research career with sPHENIX since 2019, engaging in almost all phases of the experiment, spanning hardware and software development, performance evaluation, commissioning, and physics extraction from the detector I contributed to
- The sPHENIX results have been published in JHEP 08 (2025), 075 on August 12, 2025 (my birthday), marking the first sPHENIX physics publication
  - Supporting the broader sPHENIX physics program

