



Nuclear imaging efforts at EIC

Rongrong Ma
Brookhaven National Laboratory

2026 RHIC/AGS Annual Users' Meeting & RHIC Science Symposium
May 11-15, 2026, BNL



Electron-Ion Collider

- **Decades long efforts to build the science case** since ~2000, and another decade to construct
- **2018 NAS:** “The science questions that an EIC will answer are central to *completing an understanding of atoms* as well as being integral to the agenda of nuclear physics today.”
- **2023 NSAC LRP:** “We recommend the *expeditious completion of the EIC* as the highest priority for facility construction.”

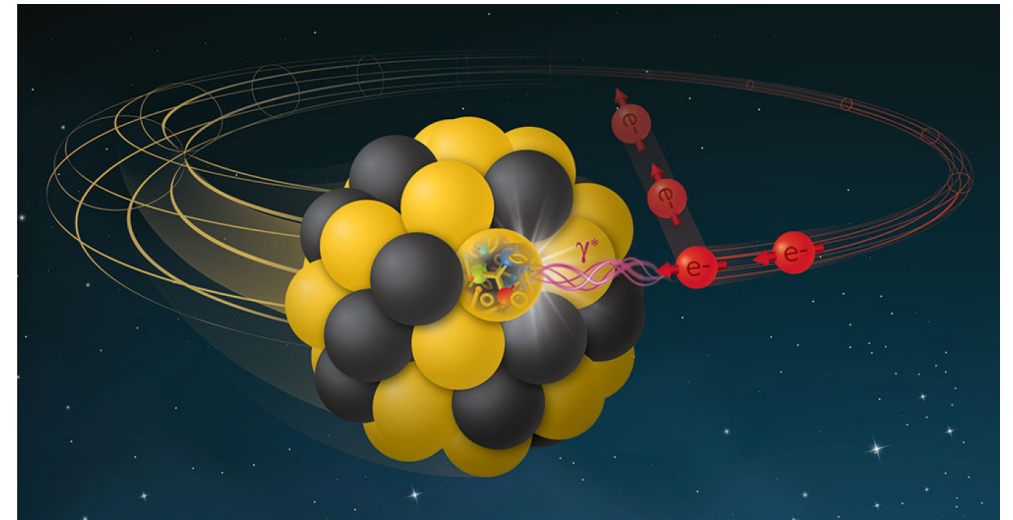

<https://www.energy.gov/science/articles/electron-ion-collider-achieves-critical-decision-1-approval>

EIC's science mission

- Study internal landscape of nucleons and nuclei, and underlying dynamics



1980s

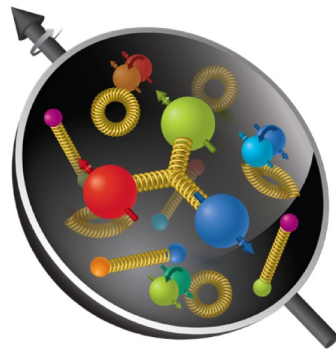

1990s to 2000s



2030s?

<https://www.bnl.gov/newsroom/factsheets/files/pdf/eic-science-overview.pdf>

- How do mass and spin come about?
- How do the confined hadronic states emerge from quarks and gluons?
- *How are partons distributed in momentum and coordinate space?*
- What are the emergent properties of dense system of gluons?

How to achieve that?

➤ High performance collider

- High luminosity: $L = 10^{33-34} \text{ cm}^{-2}\text{sec}^{-1}$
- High polarization: $P \sim 70\%$
- Wide range of energy: $\sqrt{s} \sim 29 - 100 \text{ GeV}$
- Variety of ion species: proton – Uranium

S. Diehl, et. al., arXiv:2504.01236

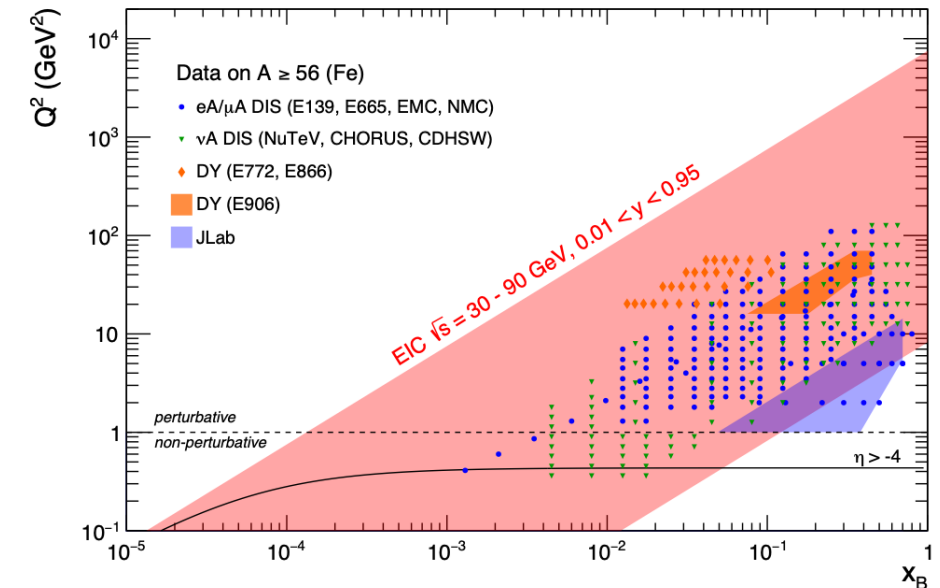

How to achieve that?

S. Diehl, et. al., arXiv:2504.01236

➤ High performance collider

- High luminosity: $L = 10^{33-34} \text{ cm}^{-2}\text{sec}^{-1}$
- High polarization: $P \sim 70\%$
- Wide range of energy: $\sqrt{s} \sim 29 - 100 \text{ GeV}$
- Variety of ion species: proton – Uranium

➤ State-of-the-art detector: ePIC

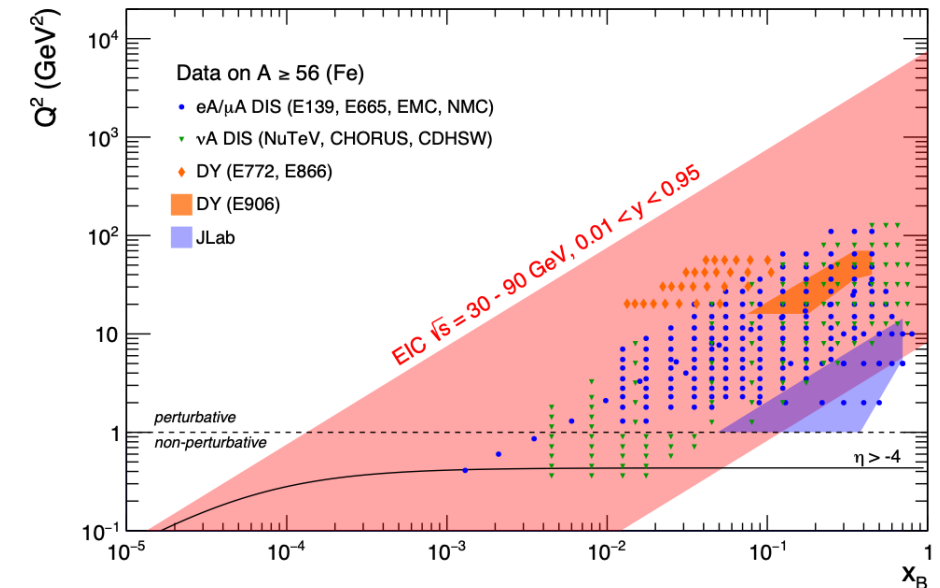
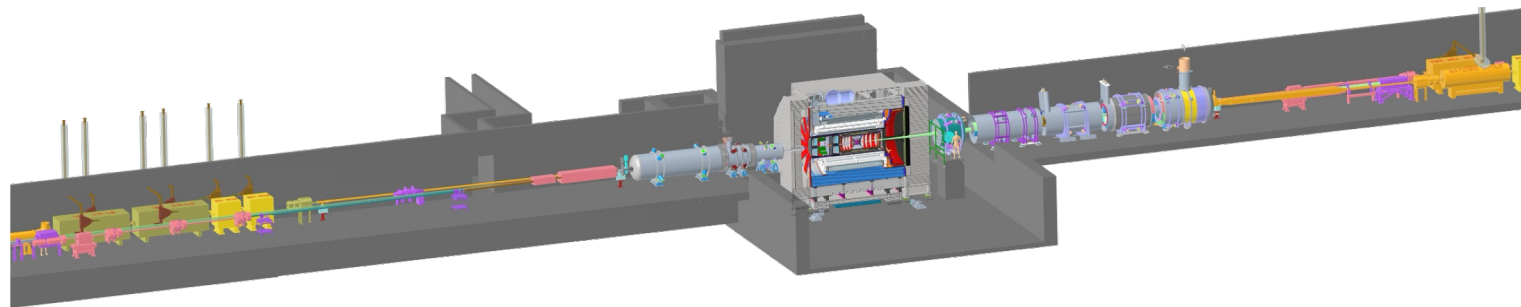

Project timeline

- RHIC operation ended on 02/06/2026; removal started on 04/01/2026
- Aim to start construction in FY27, and first beam in FY35

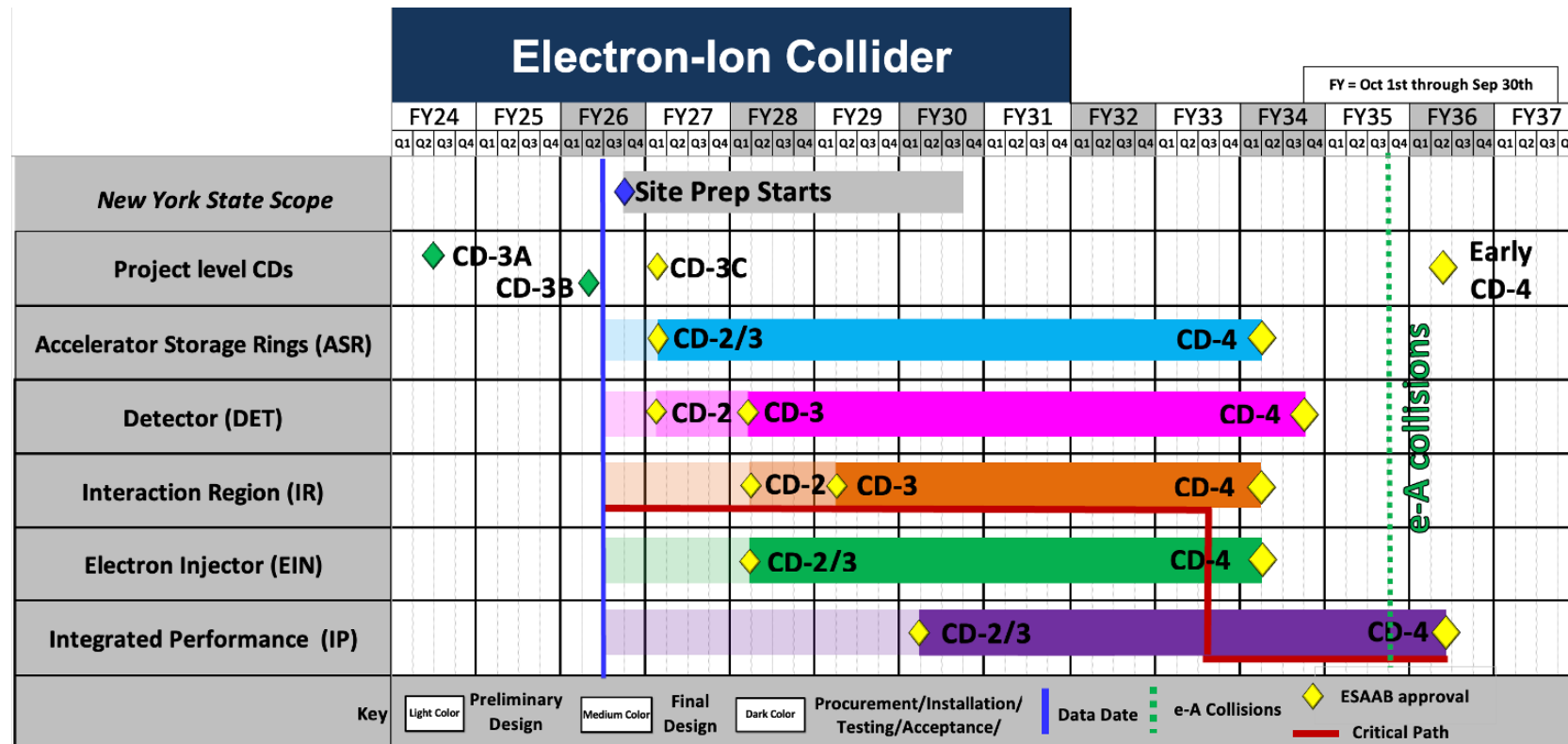

ePIC: electron-Proton/Ion Collider

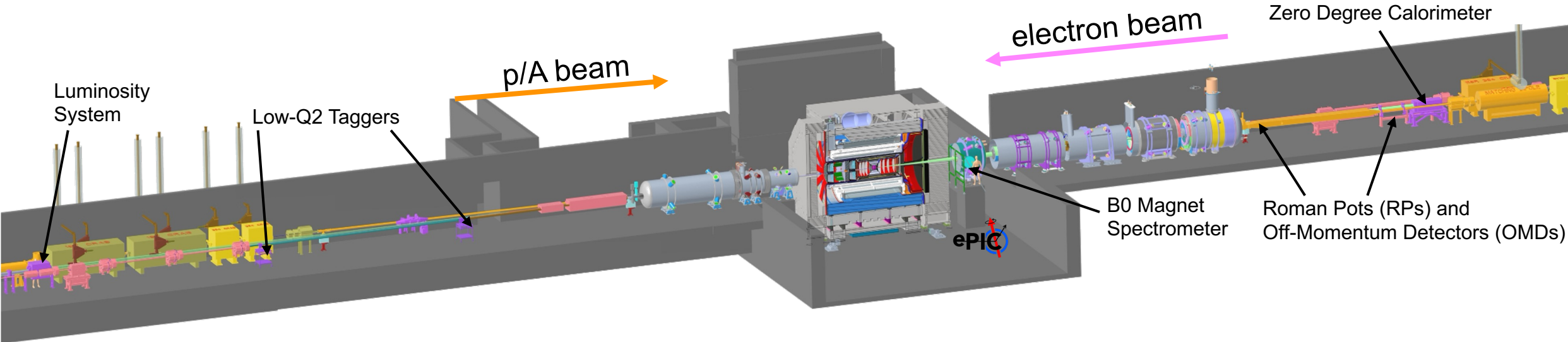

ePIC: electron-Proton/Ion Collider

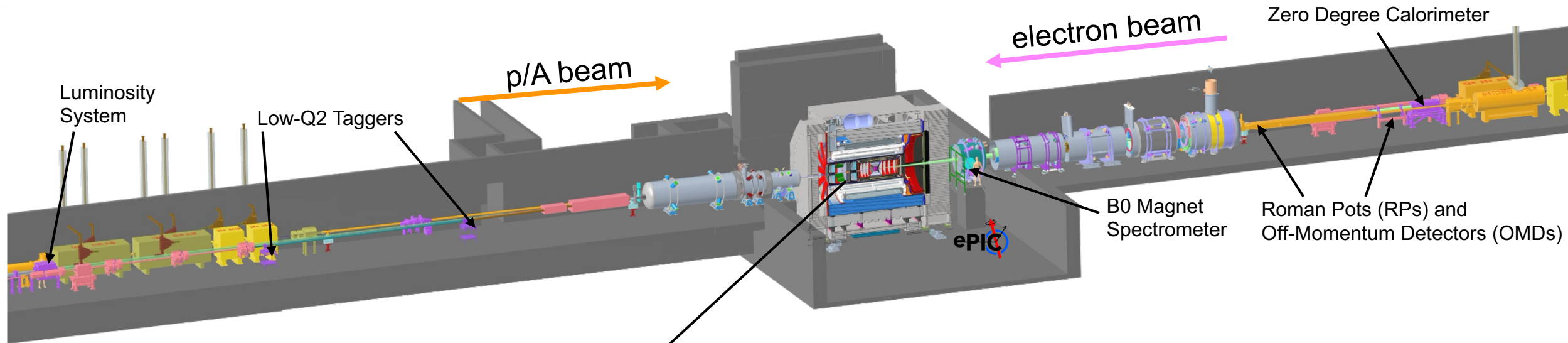

- Hadronic Calorimeters
- Solenoid Magnet
- Electromagnetic Calorimeters
- Particle Identification
- Tracking

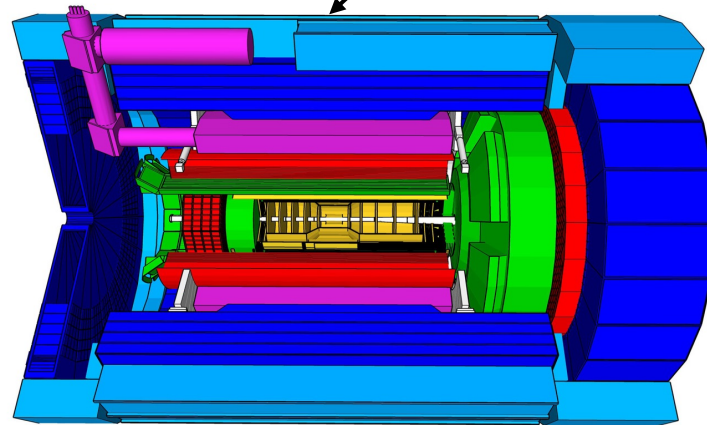

- 1.7 T superconducting solenoid
- Large acceptance ($|\eta| < 3.5$)
- Excellent tracking, secondary vertexing, calorimetry and particle identification

ePIC Collaboration

- Founded in July 2022
- International: 1100+ collaborators, 180+ institutions, 26 countries
- ePIC is a CERN recognized experiment

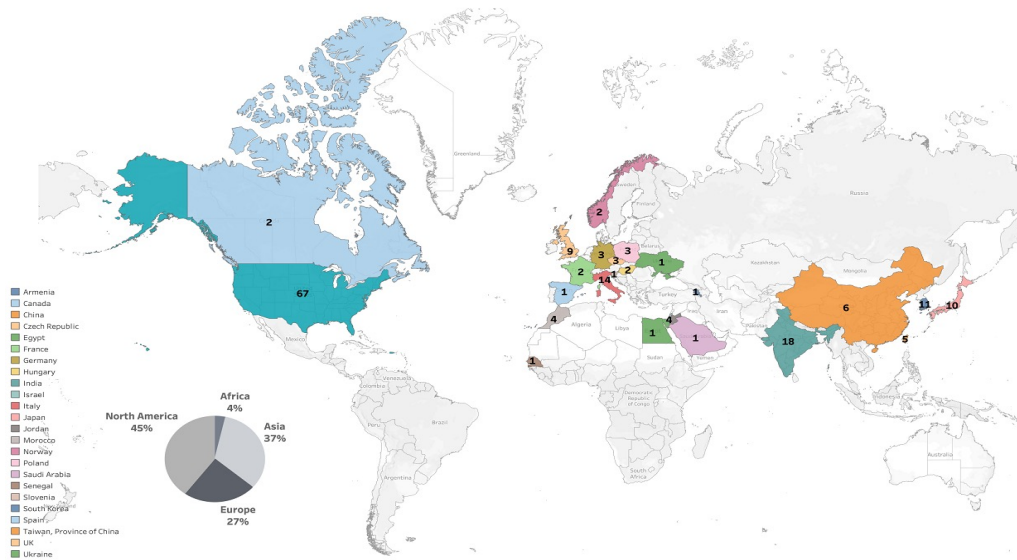

Imaging: momentum space

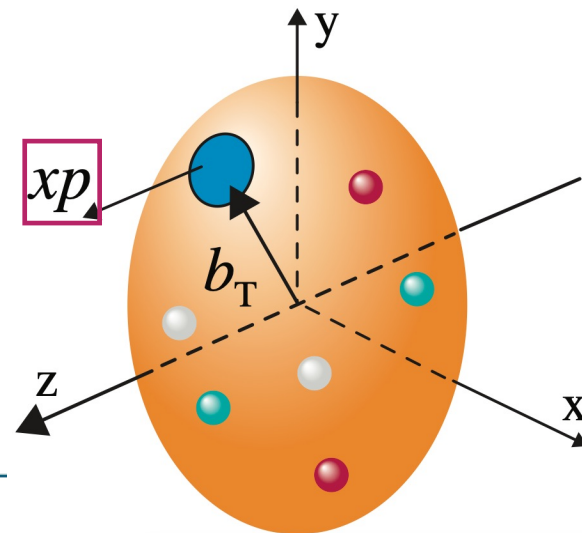

Constrain nPDF with DIS

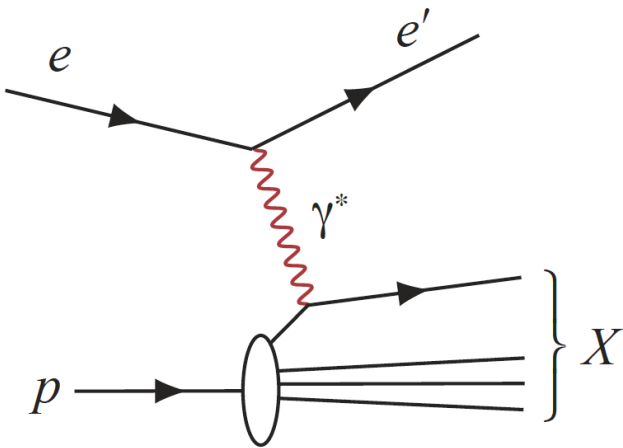

$$\sigma \propto F_2(x, Q^2) - \frac{y^2}{1 + (1 - y)^2} F_L(x, Q^2)$$

Constrain nPDF with DIS

EIC yellow report: arXiv:2103.05419

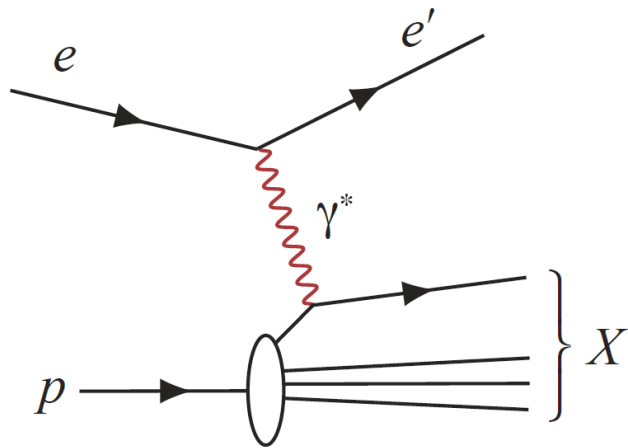

$$\sigma \propto F_2(x, Q^2) - \frac{y^2}{1 + (1 - y)^2} F_L(x, Q^2)$$

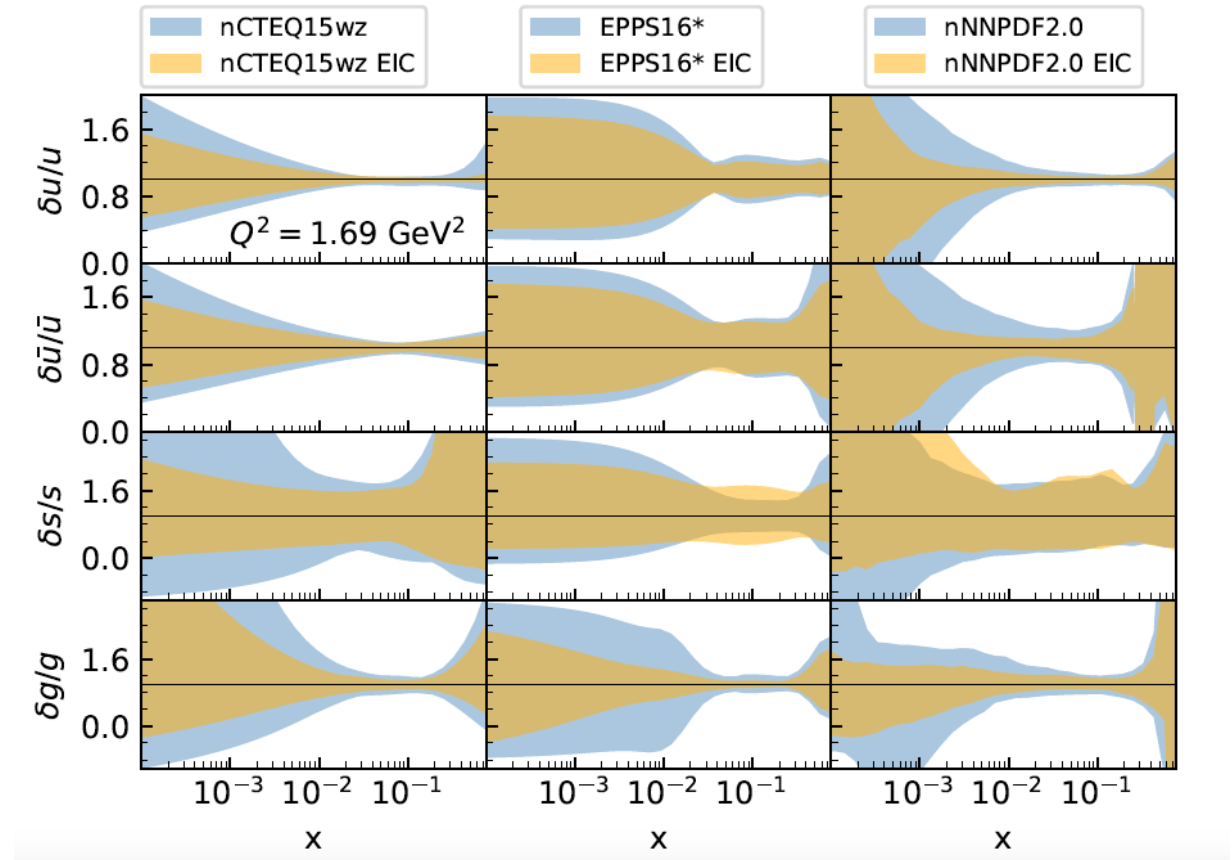

➤ Constrain nPDF across the board

Constrain gluon nPDF with charm

- Leading-order: photon-gluon fusion → sensitive probe of gluons

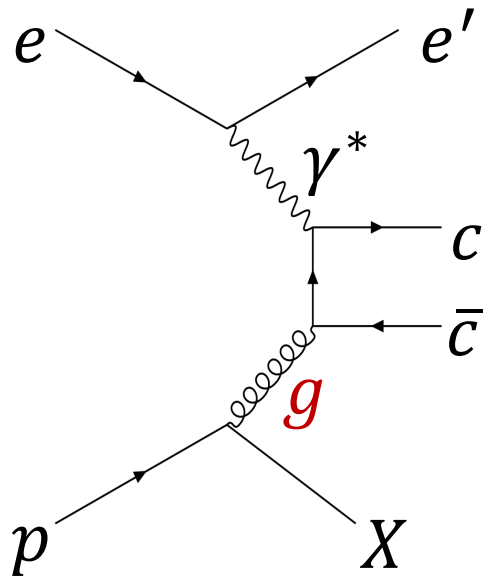

Constrain gluon nPDF with charm

- Leading-order: photon-gluon fusion → **sensitive probe of gluons**

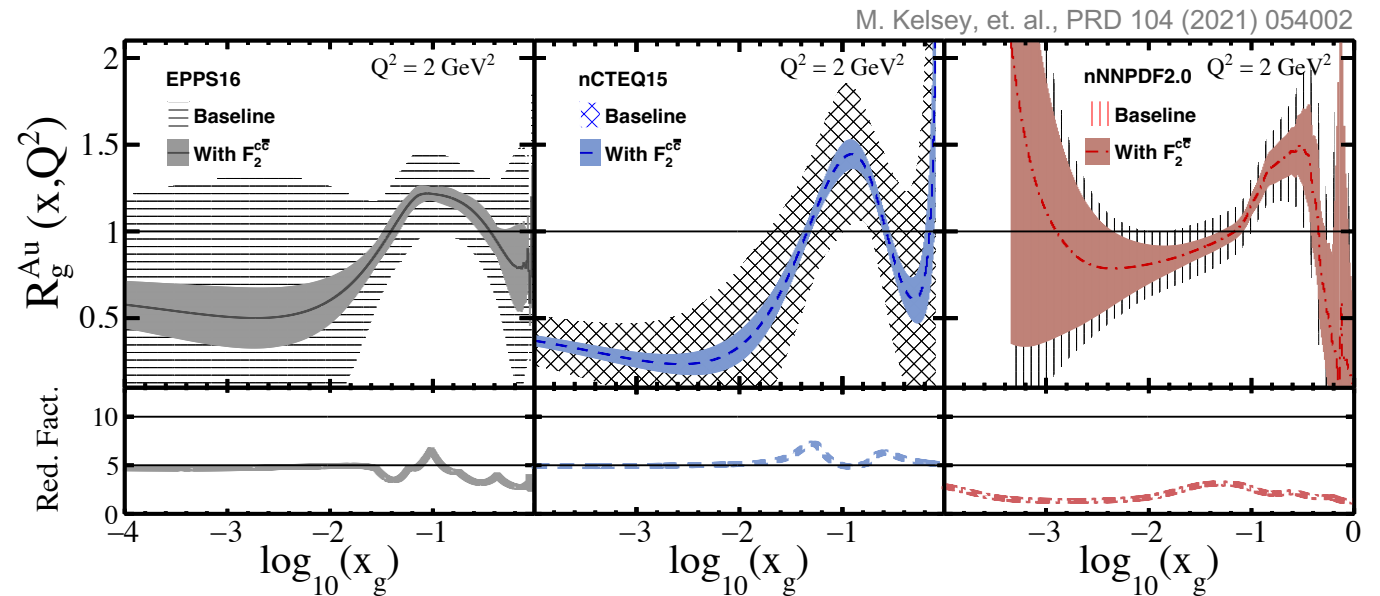
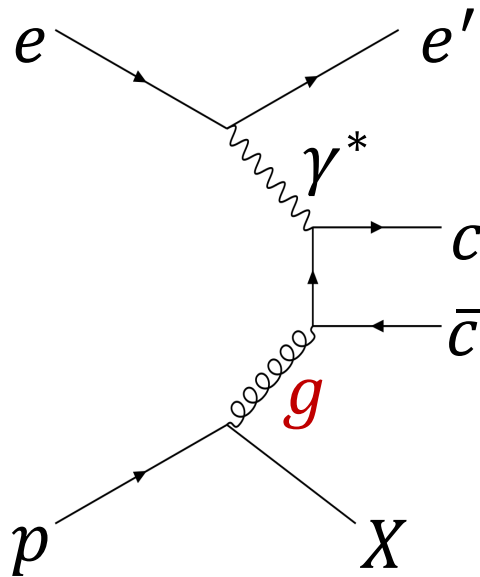

- Complimentary to inclusive measurements, especially **at high x**

Charm hadron reconstruction

- Use helix swimming to reconstruct decay topology

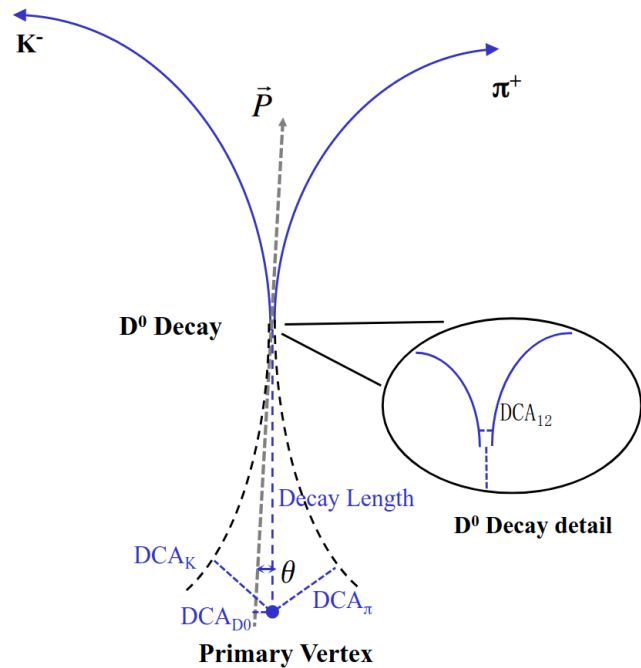

STAR, PRC 102 (2020) 014905

Charm hadron reconstruction

- Use helix swimming to reconstruct decay topology

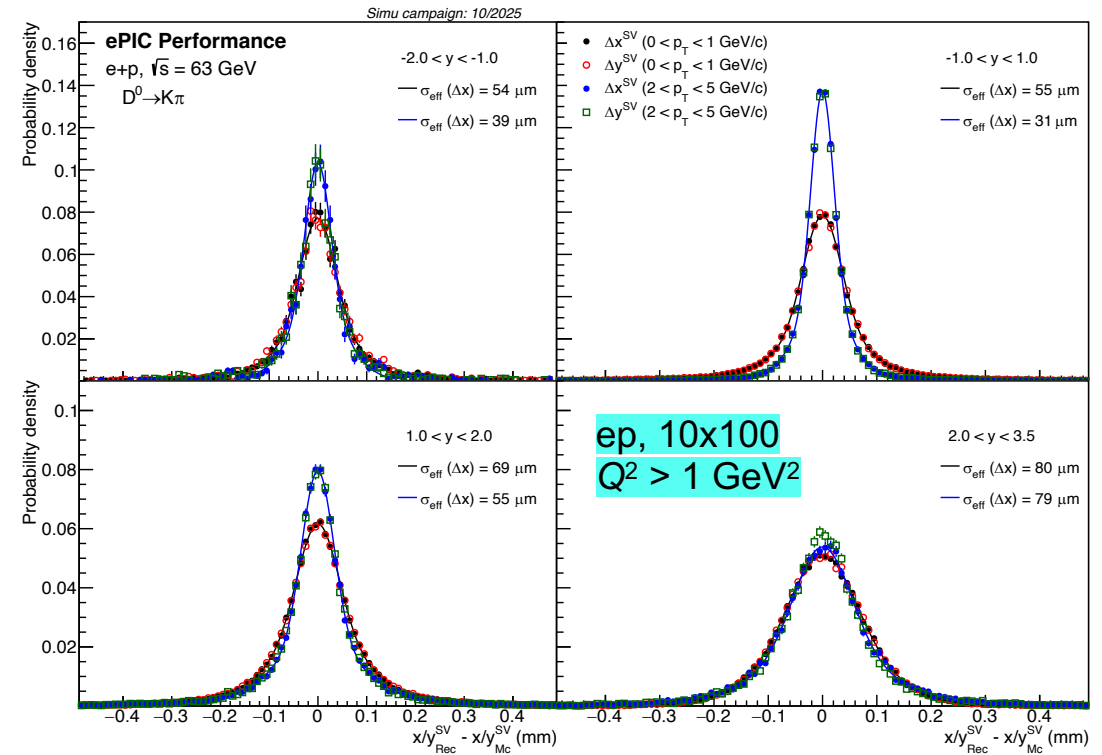
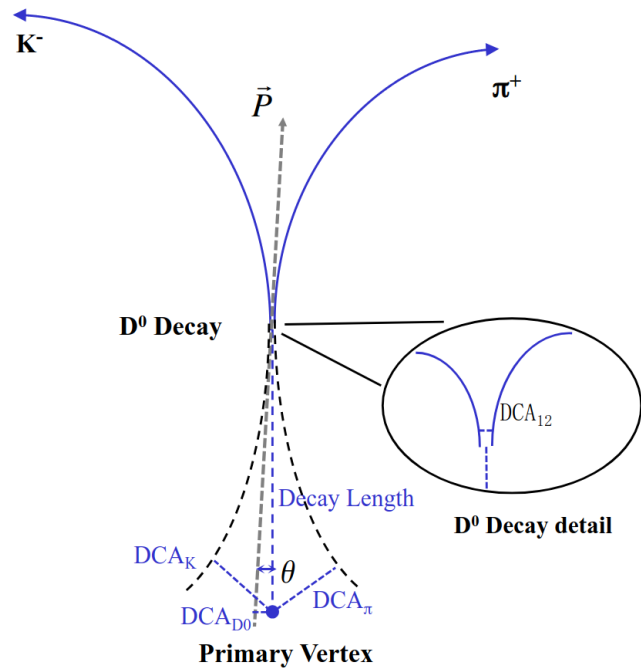

STAR, PRC 102 (2020) 014905

- Excellent resolution for D⁰ decay vertex

Charm hadron reconstruction

- Use ML to improve signal significance

ep, 10x100, $Q^2 > 1 \text{ GeV}^2$

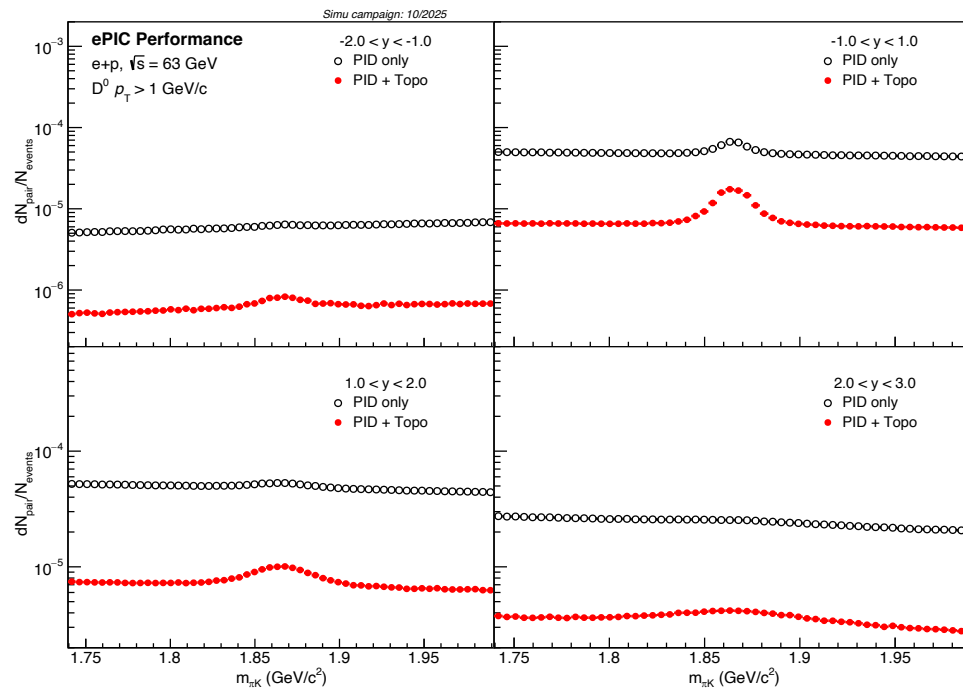

eAu, 10x100, $Q^2 > 1 \text{ GeV}^2$

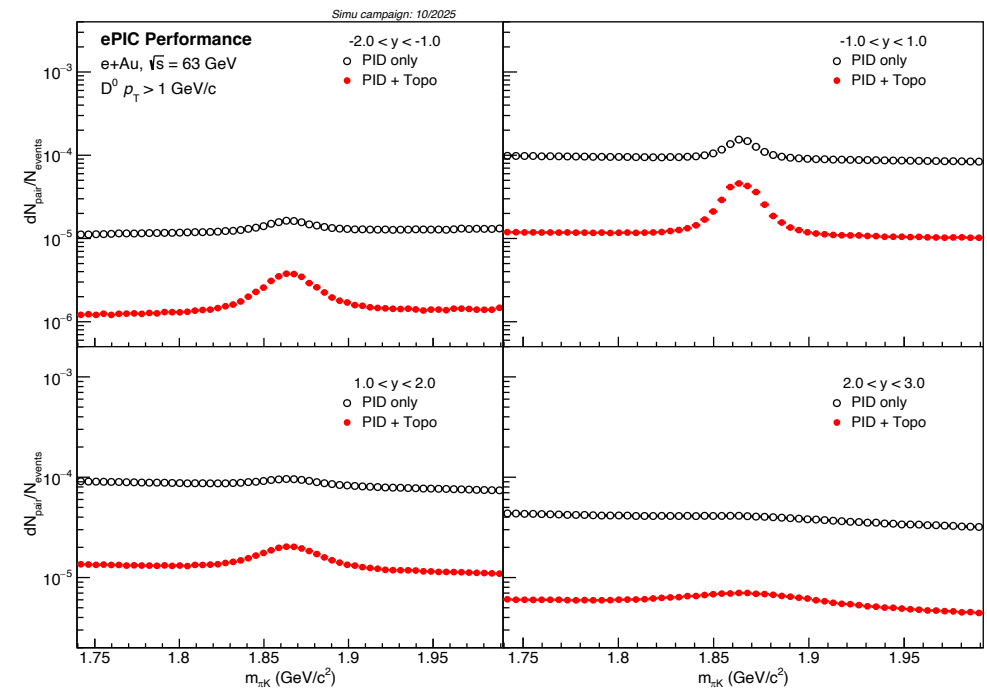

Imaging: coordinate space

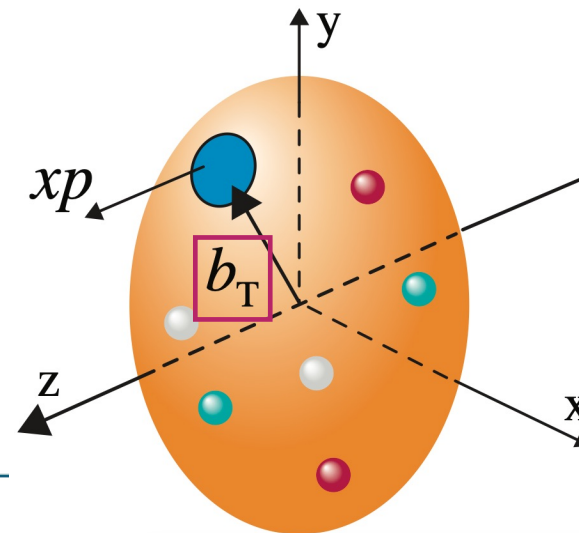

Image quarks

- DVCS: Deeply Virtual Compton Scattering

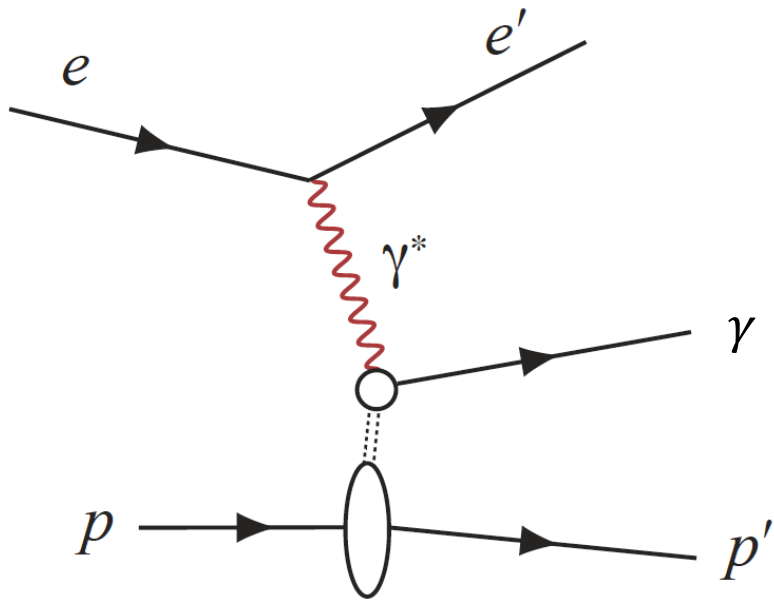
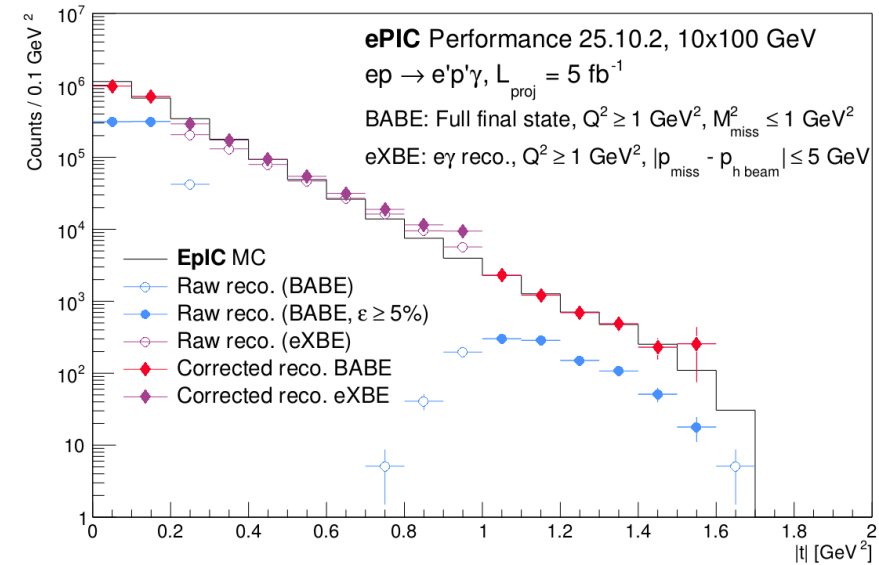
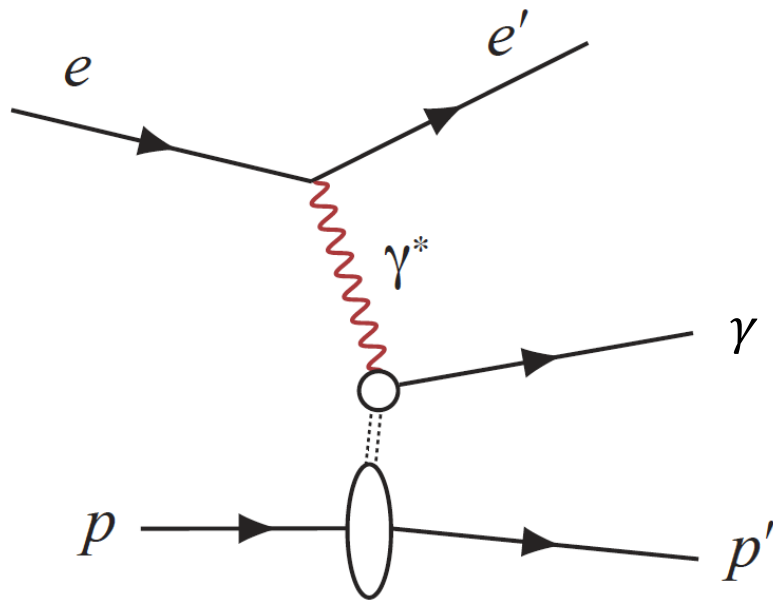

Image quarks

➤ DVCS: Deeply Virtual Compton Scattering



- t construction method varies in different ranges
- Fourier transfer to obtain impact parameter dependence
- **Challenging for heavy nuclei**

Image gluons

➤ Exclusive Vector Meson Production

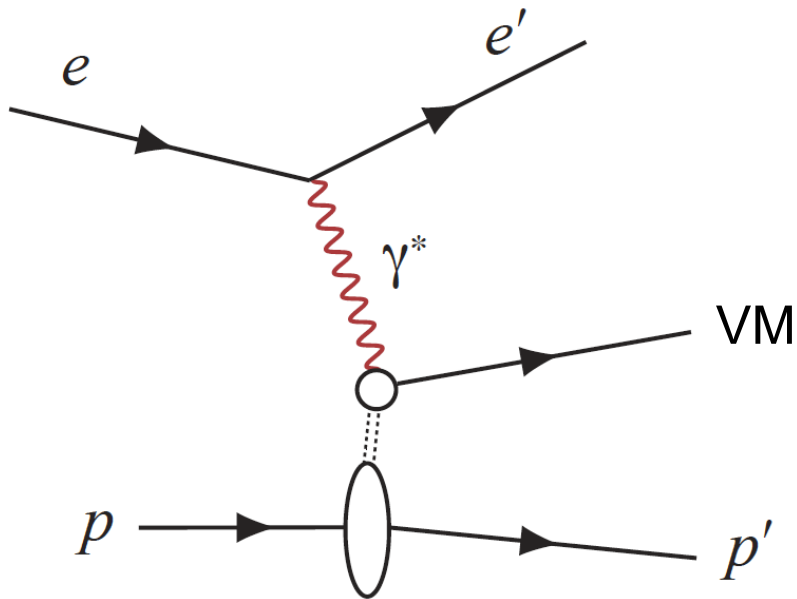

- Exchange Pomeron (two-gluon object)
- Coherent: gluon spatial distribution
- Incoherent: gluon spatial fluctuations

Image gluons: challenges

- Challenge 1: *limited resolution in measuring $|t|$*
- Diffractive patterns are largely washed out, making Fourier transformation very difficult

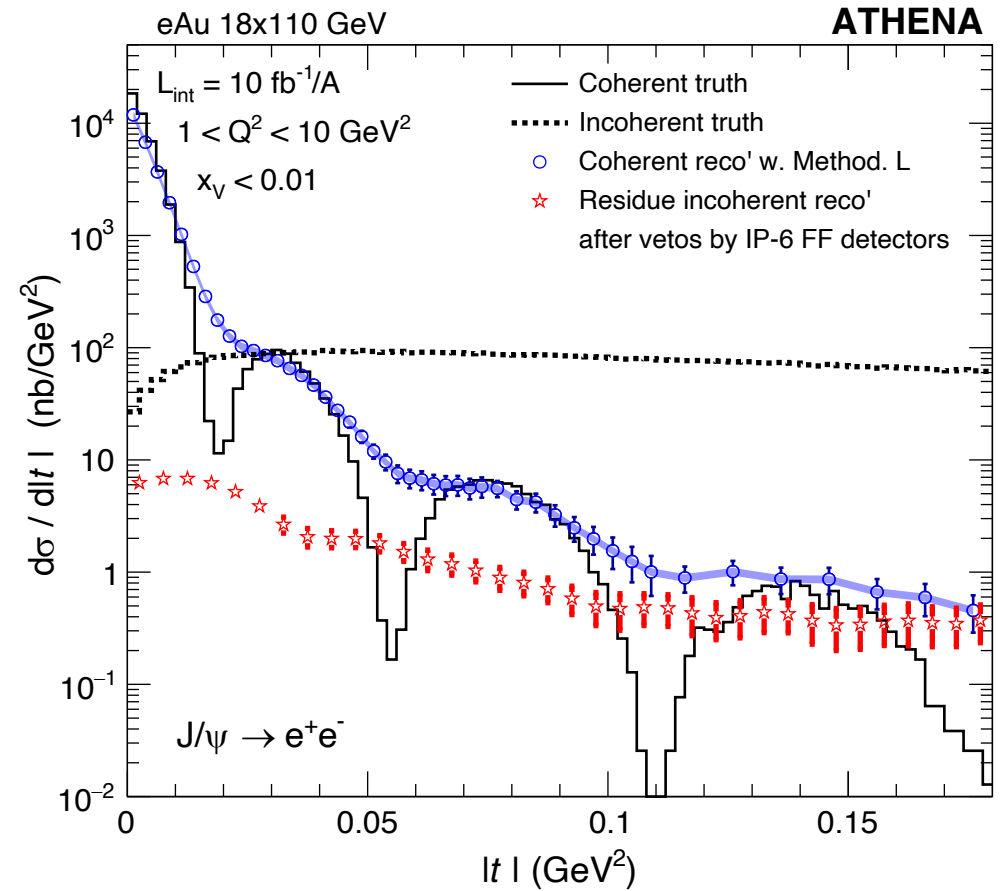

Image gluons: challenges

- Challenge 1: *limited resolution in measuring $|t|$*
 - Diffractive patterns are largely washed out, making Fourier transformation very difficult
- Challenge 2: *incoherent background*
 - Still overshadows 2nd and 3rd minima after detector vetos

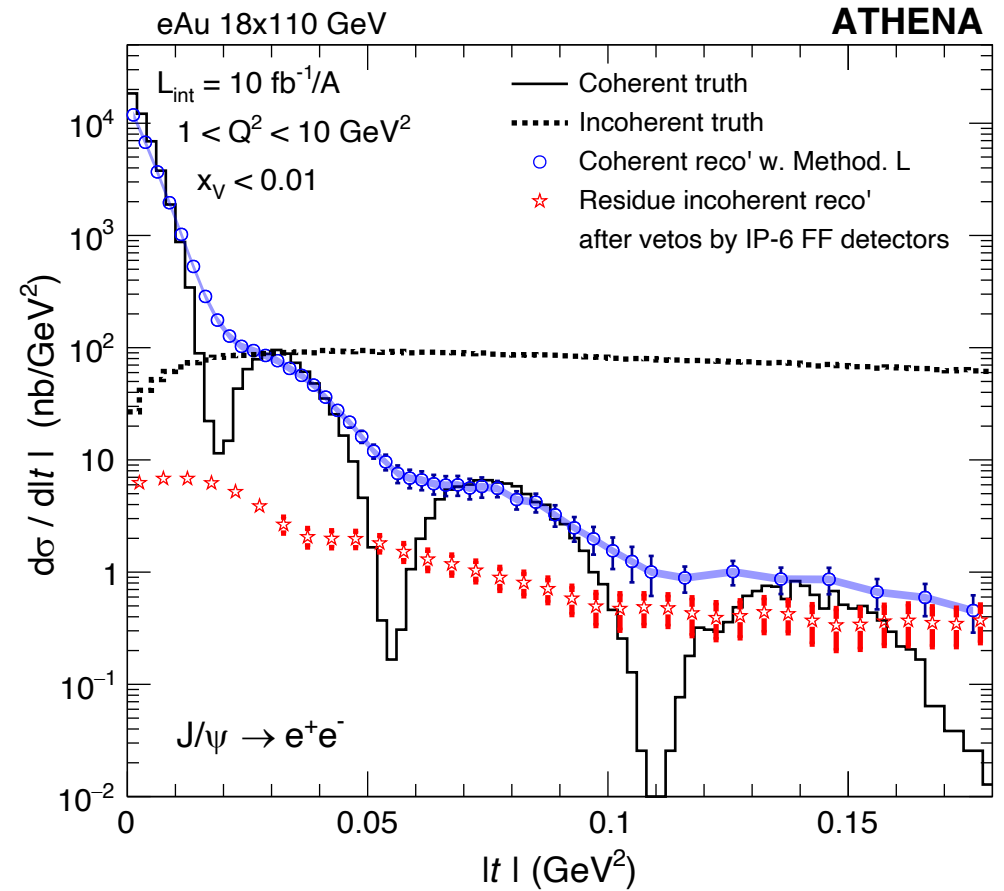
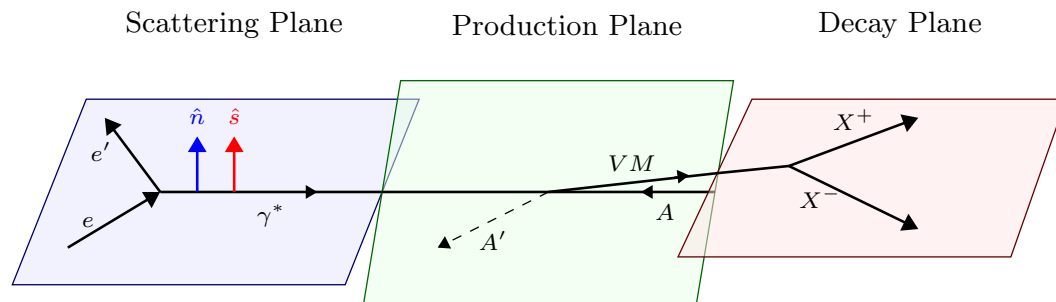

Image gluons: projective imaging

- Challenge 1: *limited resolution in measuring $|t|$*
- Solution: restrict to the **normal direction of the scattering plane** to minimize the effect of momentum resolution



M. Kesler, et. al., arXiv: 2502.15596

Image gluons: projective imaging

- Challenge 1: *limited resolution in measuring $|t|$*
- Solution: restrict to the **normal direction of the scattering plane** to minimize the effect of momentum resolution

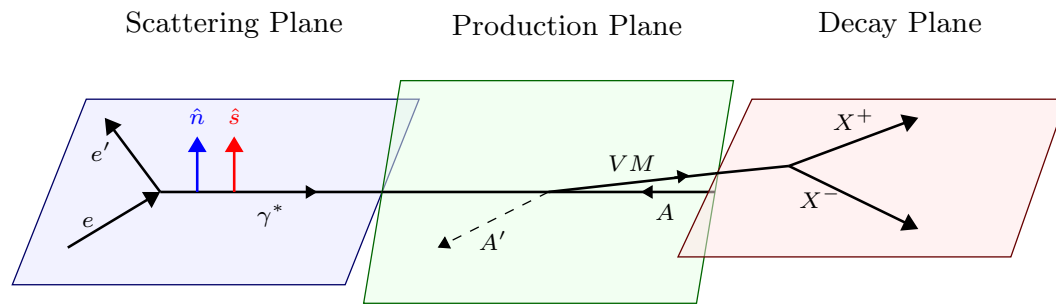

M. Kesler, et. al., arXiv: 2502.15596

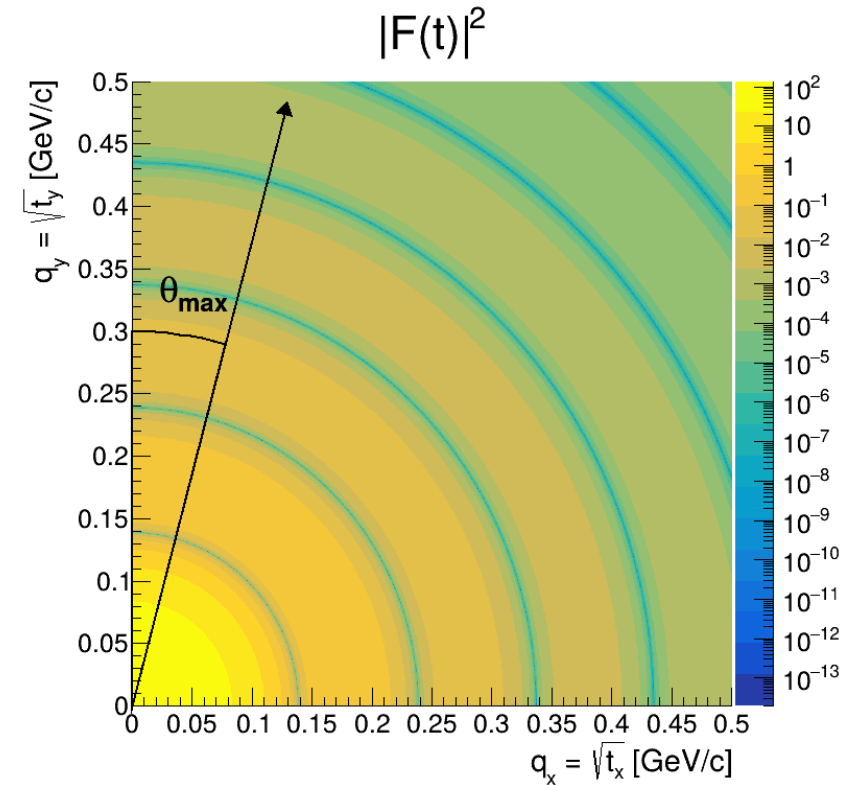
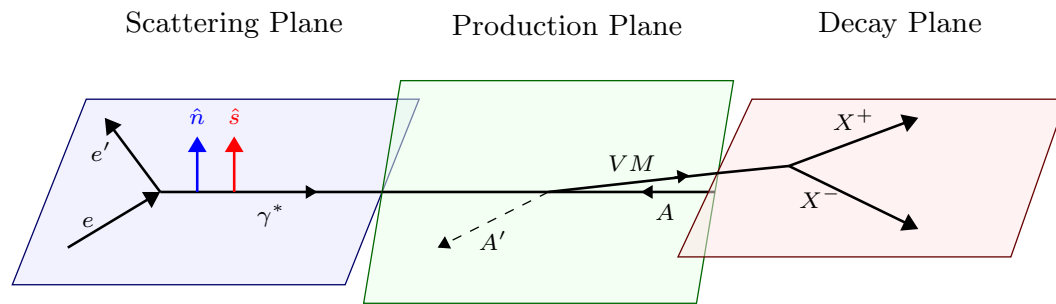

Image gluons: projective imaging

- Challenge 1: *limited resolution in measuring $|t|$*
- Solution: restrict to the **normal direction of the scattering plane** to minimize the effect of momentum resolution



M. Kesler, et. al., arXiv: 2502.15596

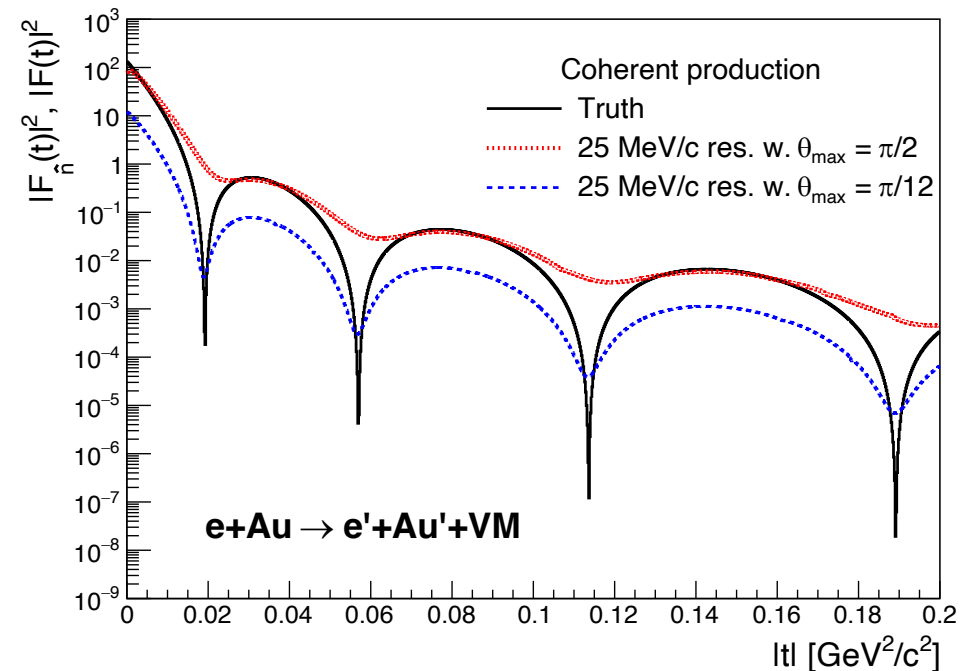
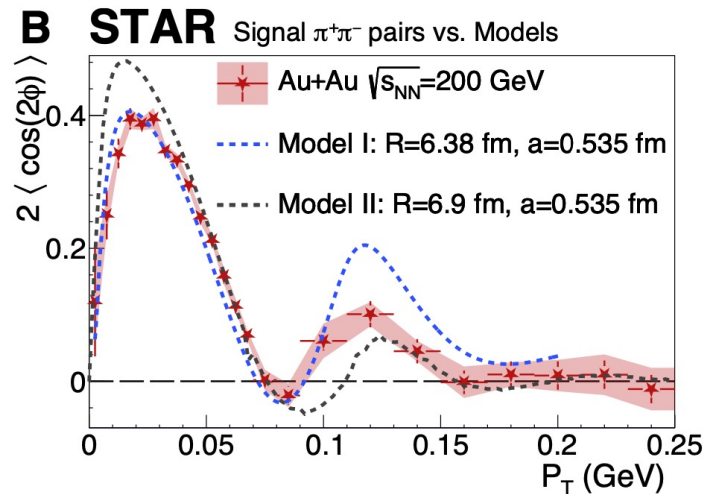

Image gluons: spin density matrix

- Challenge 2: *incoherent background*
- Solution: utilize **VM's decay pattern** to statistically separate coherent and incoherent components

STAR, Sci. Adv. 9, abq3903 (2023)



- UPC
 - Coherent: $\sim 100\%$ spin transfer from photon to VM
 - Incoherent: little spin transfer

Image gluons: spin density matrix

- Challenge 2: *incoherent background*
- Solution: utilize **VM's decay pattern** to statistically separate coherent and incoherent components

STAR, Sci. Adv. 9, abq3903 (2023)

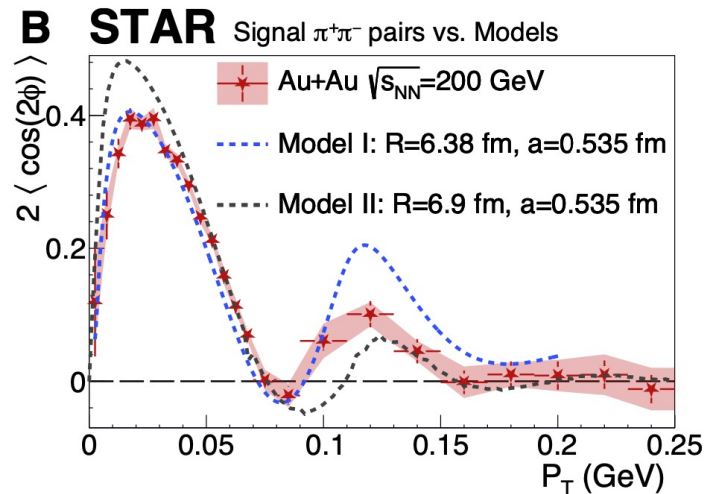

- UPC
 - Coherent: $\sim 100\%$ spin transfer from photon to VM
 - Incoherent: little spin transfer

ZEUS, EPJC 12 (2000) 393

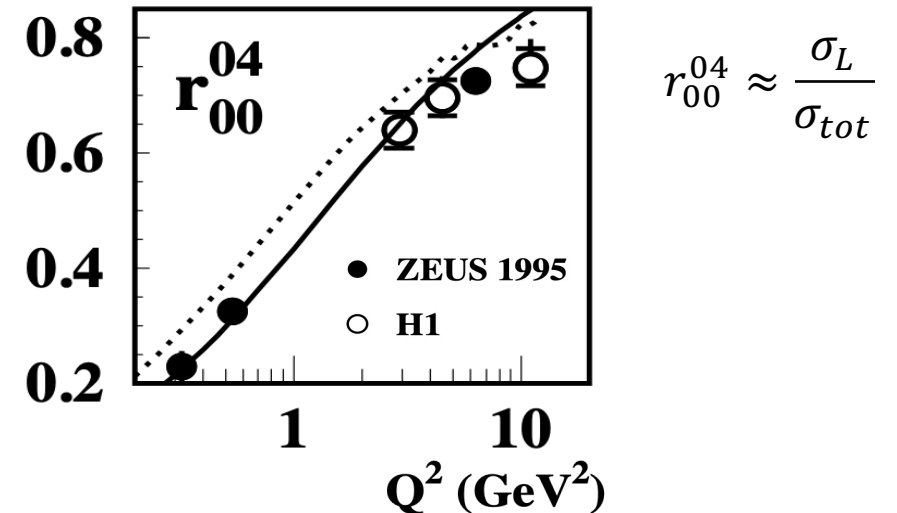

- DIS
 - Coherent: $\sim 100\%$ spin transfer
 - Incoherent: not known

Image gluons: spin density matrix

- Challenge 2: *incoherent background*
- Solution: utilize **VM's decay pattern** to statistically separate coherent and incoherent components
- Coherent
 - VM inherits the virtual photon polarization
 - Non-trivial decay patterns w.r.t. to photon polarization
- Incoherent
 - Assume no spin transfer from virtual photon to VM or **should this be the new definition?**
 - No particular decay patterns
- Separate them apart on an ensemble basis in addition to detector veto
- This approach is being actively pursued: M. Kesler, et. al., arXiv: 2502.15596

Summary

- Electron-Ion Collider: a unique opportunity to provide 3D imaging of nucleons and nuclei
 - Complete reconstruction of scattering kinematics
 - Currently on track to be baselined; aim to start construction in ~FY27 and deliver first beam in ~FY35
- ePIC: general-purpose detector equipped with modern technology
 - nPDF: inclusive DIS, semi-inclusive D^0
 - Gluon spatial distribution: exclusive VM production
- Critical constraints of initial conditions for heavy-ion simulations