



# The Origins of sPHENIX

David Morrison (BNL)

RHIC AUM 2026



ON THE  
ORIGIN  
OF  
S P H E N I X  
—  
D A R W I N .

A: 2009

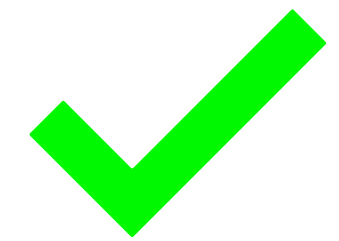

B: 2013

C: 2015

D: sPHENIX isn't real

## Appendix A

### Charge Letter

From: Vigdor, Steven <vigdor@bnl.gov>  
Date: Wed, Dec 16, 2009 at 6:44 PM  
Subject: Charge for new decadal plans for STAR and PHENIX  
To: Barbara Jacak <jacak@skipper.physics.sunysb.edu>, Nu Xu <nxu@lbl.gov>

Dear Barbara and Nu,

As we have discussed in Spokesperson's Meetings, I am herein charging the PHENIX and STAR Collaborations with generating new decadal plans that lay out your proposed science goals and detector upgrade paths for the period 2011-2020. The decadal plans generated in 2003 have been extremely useful for RHIC and both experiments. Now that we have received (or are on the verge of receiving) funding to carry out most of the upgrades described in those earlier reports, it is timely to develop a clear roadmap for what comes next. With current funding profile guidance from DOE, it appears that the STAR Heavy Flavor Tracker may be completed in FY2015, and the suite of significant PHENIX upgrades are likely to be completed sooner. We also anticipate that the various RHIC machine luminosity upgrades under way (six planes of stochastic cooling, 56 MHz SRF rebunching, electron lenses) or contemplated (low-energy electron cooling) will be completed by 2015. Not unexpectedly, then, we are being asked by DOE what plans we have for RHIC beyond 2015.

I am therefore asking you to generate a document for each Collaboration, to be delivered to me by August 1 [October 1], 2010, that provides the following information:

1) A brief summary of the detector upgrades already (or soon to be) in progress, the timelines for completing them, the new science capabilities each adds in combination with upgraded RHIC luminosity, and your best current estimates (informed by the current strawman 5-year run plan for RHIC) of when you will be able to acquire the data that addresses the relevant science goals. This can even be summarized in tabular form, and should be consistent with the latest RHIC Midterm Plan.

2) The compelling science goals you foresee for RHIC A+A, p+p, and d+A collisions that can only be carried out with additional upgrades (or replacements) of detector subsystems or machine ca-

207

From: **Vigdor, Steven** <vigdor@bnl.gov>

Date: Wed, **Dec 16, 2009** at 6:44 PM

Subject: Charge for new decadal plans for STAR and PHENIX

To: **Barbara Jacak** <jacak@skipper.physics.sunysb.edu>, **Nu Xu** <nxu@lbl.gov>

2) The **compelling science goals you foresee for RHIC A+A, p+p, and d+A** collisions that can only be carried out with additional upgrades (or replacements) of detector subsystems or machine capabilities (e.g., further luminosity or diamond size improvements). For each such goal, provide some explanation of why RHIC is the appropriate facility (e.g., in competition with LHC or FAIR) to pursue that science, and preferably some simulations that **demonstrate the need for new detector or machine capabilities to address the compelling questions**. If the pursuit of some science goals is conditional on results to be obtained over the next several years, try to outline the decision points you foresee for deciding future paths.

4) **Any plans or interest your Collaboration has in adapting your detector or detector subsystems (or detector R&D) to study electron-nucleon and electron-ion collisions with an eventual eRHIC upgrade**. This is relevant only near the end of the decade addressed here, but will be important for planning purposes. (We may well be forced by financial or environmental considerations, even for a first MeRHIC stage, to consider options in which acceleration of the electron beam is carried out around the RHIC tunnel, requiring some scheme for getting an electron beamline through or around PHENIX and STAR. So it is worth considering if there is some way you could make use of the e-p and e-A collisions if we provided them.)

# The PHENIX Experiment at RHIC

*Decadal Plan 2011–2020*

Brookhaven National Laboratory

Relativistic Heavy Ion Collider

October, 2010



Spokesperson

Deputy Spokesperson

Deputy Spokesperson

Operations Director

Deputy Operations Director for Upgrades

Deputy Operations Director for Operations

Barbara Jacak

*Stony Brook University*

Jamie Nagle

*University of Colorado*

Yasuyuki Akiba

*RIKEN Nishina Center for*

*Accelerator-Based Science*

Ed O'Brien

*Brookhaven National Laboratory*

Mike Leitch

*Los Alamos National Laboratory*

John Haggerty

*Brookhaven National Laboratory*

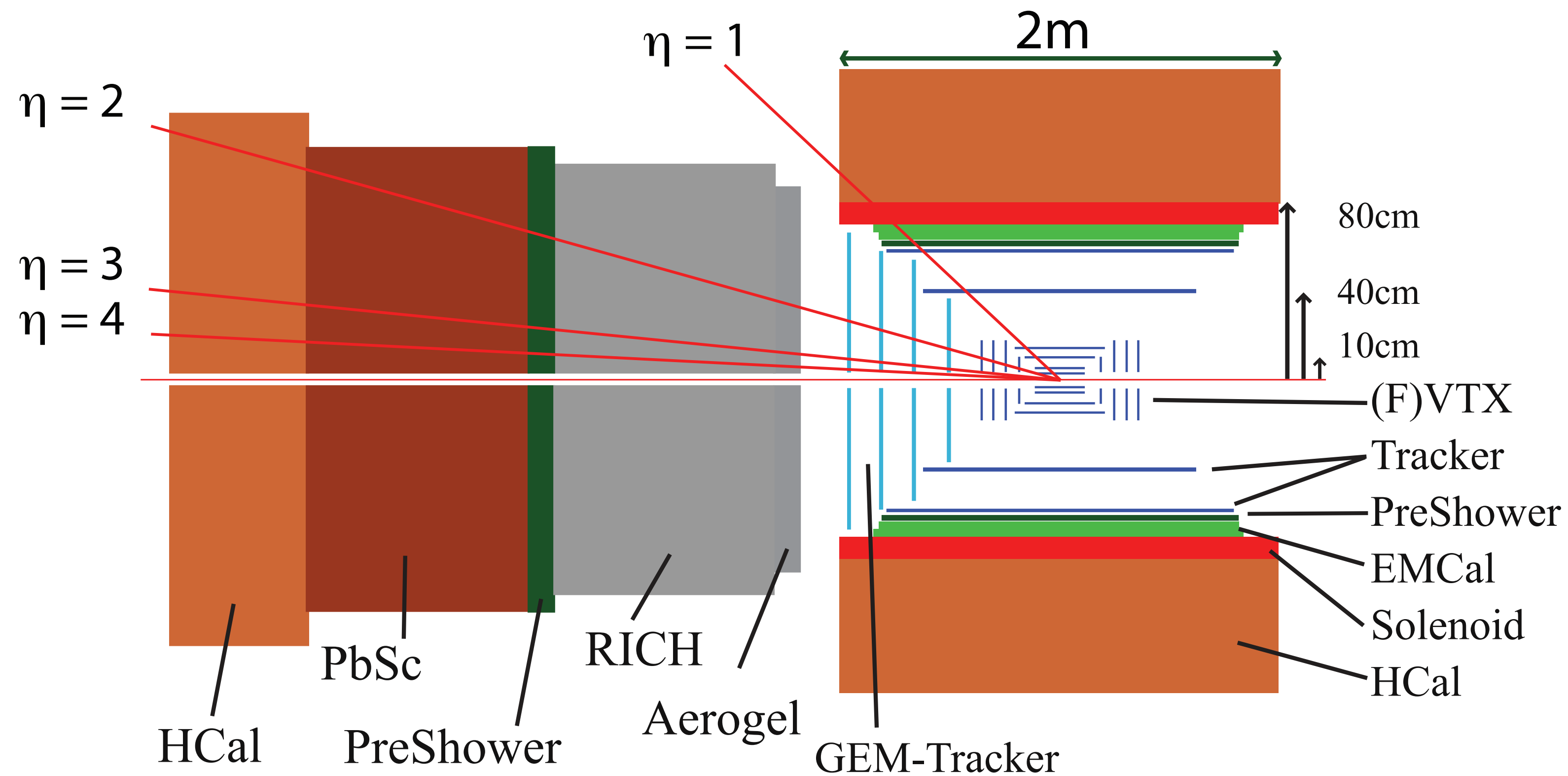

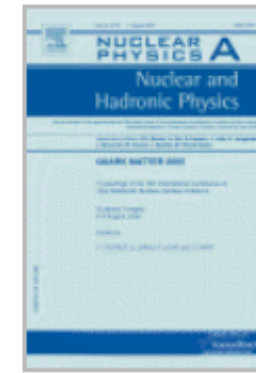

# Toward the theory of strongly coupled Quark-Gluon Plasma (sQGP)

Edward Shuryak<sup>a</sup>

Show more ▾

+ Add to Mendeley Cite

<https://doi.org/10.1016/j.nuclphysa.2006.06.058>

[Get rights and content](#)

We review recent progress toward understanding of sQGP. The phenomenological part includes discussion of elliptic and conical flows at RHIC. Then we proceed to first quantum mechanical studies of manybody states at  $T > T_c$ , the “polymeric chains”  $\bar{q} \cdot g \cdot g \dots q$  and baryons. A new model for sQGP is a classical dynamical system, in which color vector is changed via the Wong equation. First Molecular Dynamics (MD) results for its diffusion and viscosity are reported. Finally we speculate how strong correlations in matter may help solve puzzles related to jet quenching, both the magnitude and angular distribution.

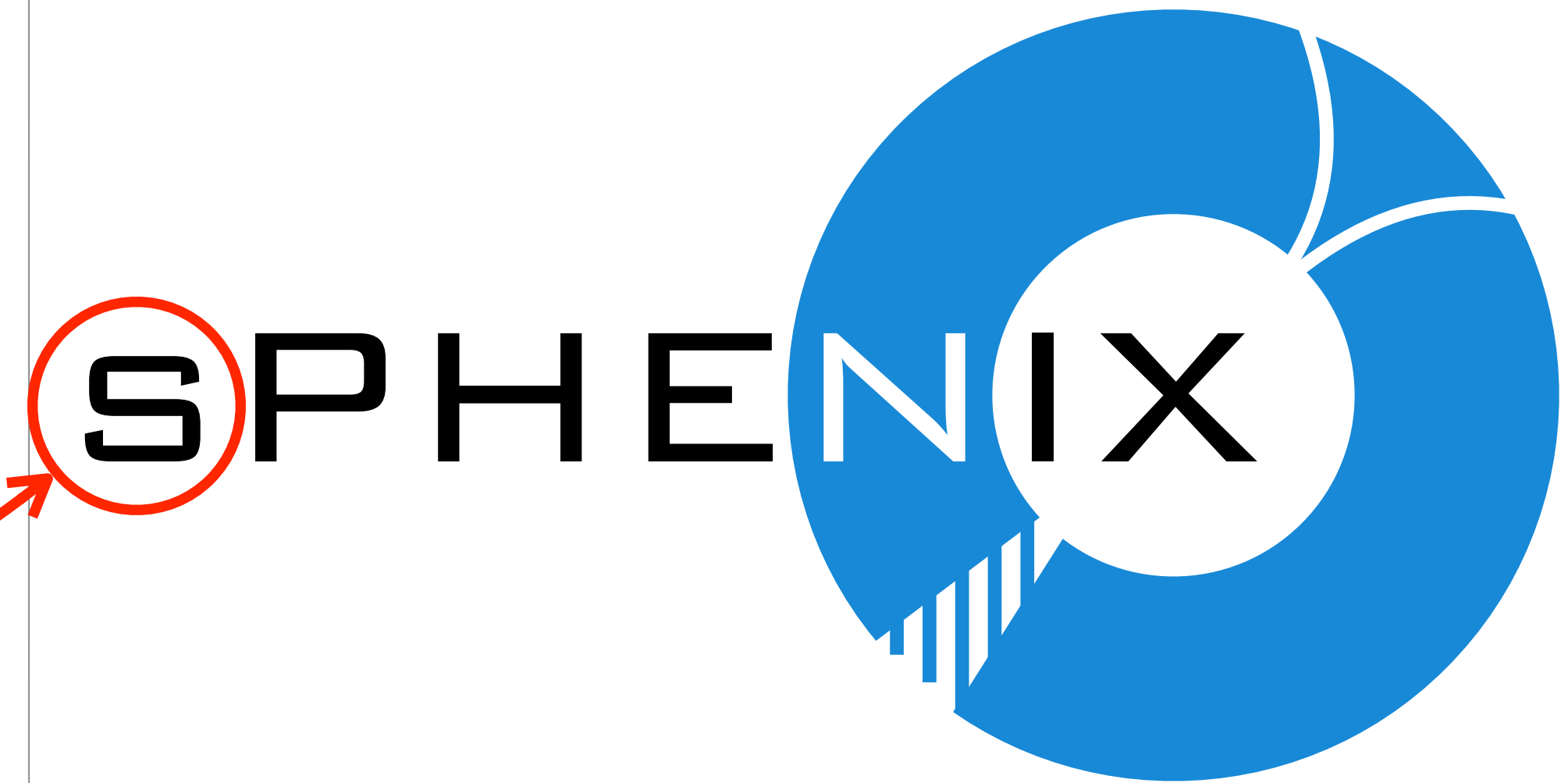

sPHENIX ca. 2012

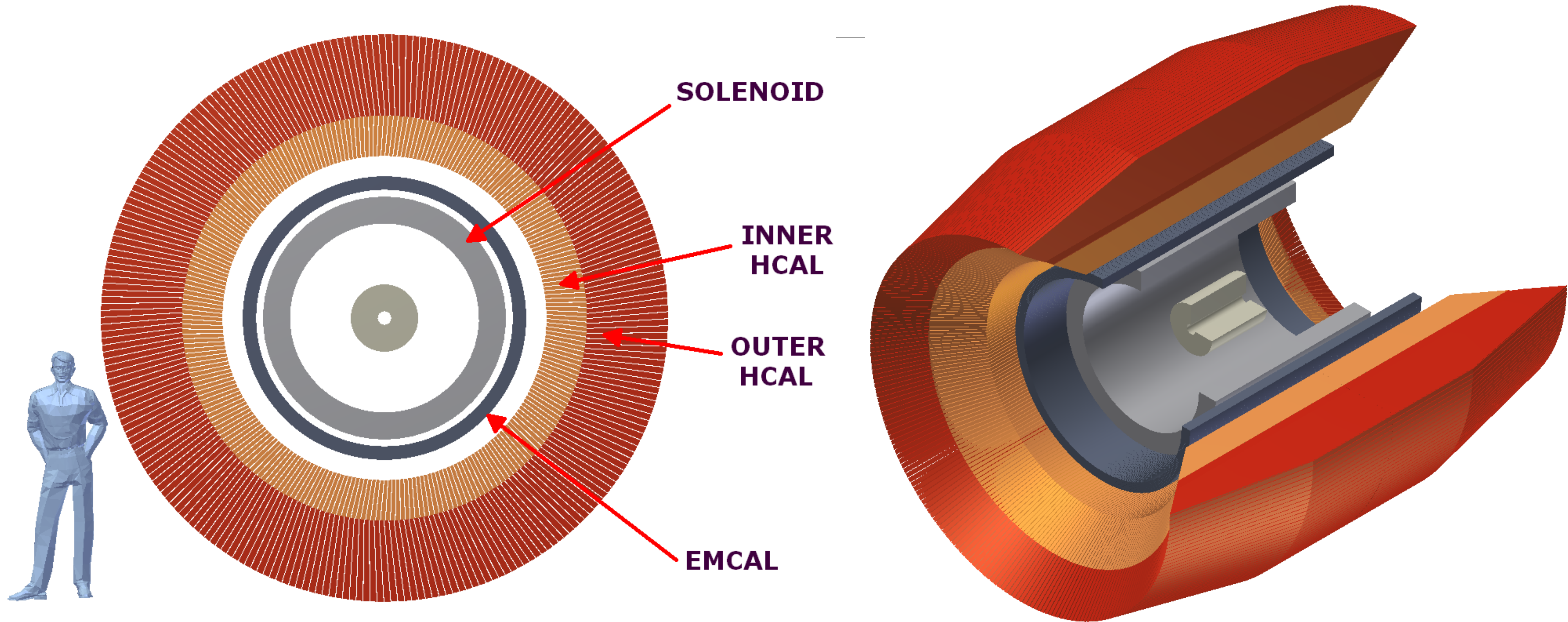

Decommissioned solenoids of CLEO, CDF, D0, and **BaBar** investigated but none seemed appropriate

# Original HCal artwork

E. Kistenev

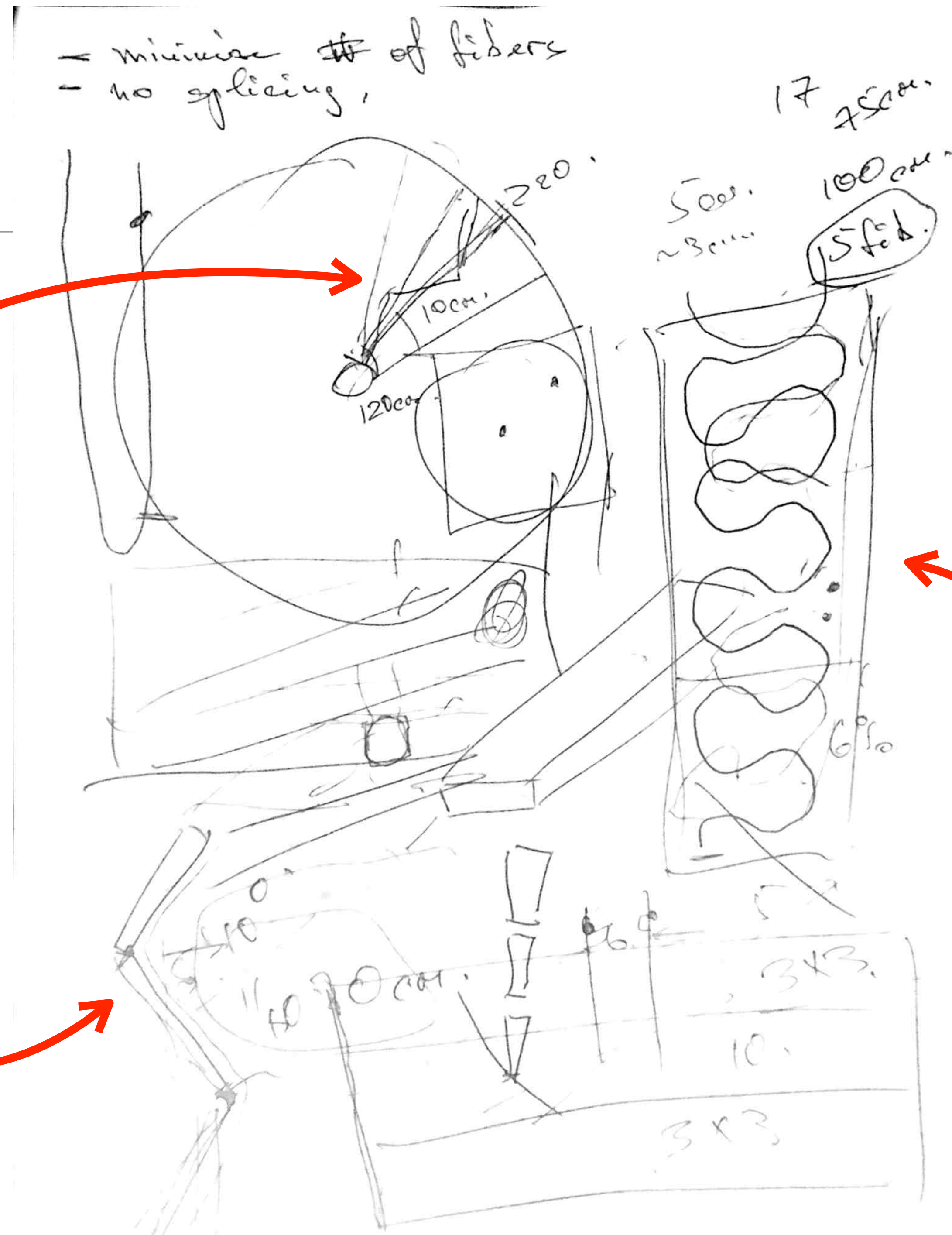

Tilted steel plates:  
absorber doubles as  
structural support

WLS fibers in  
scintillating tiles

# Electromagnetic calorimeter

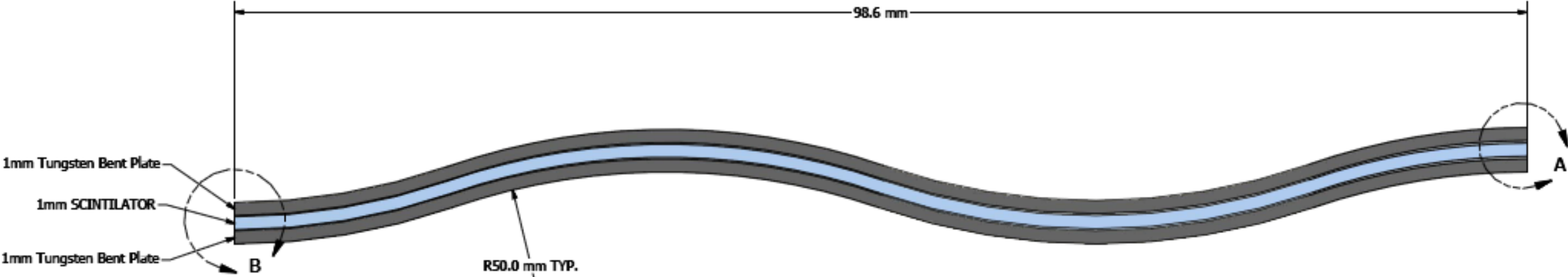
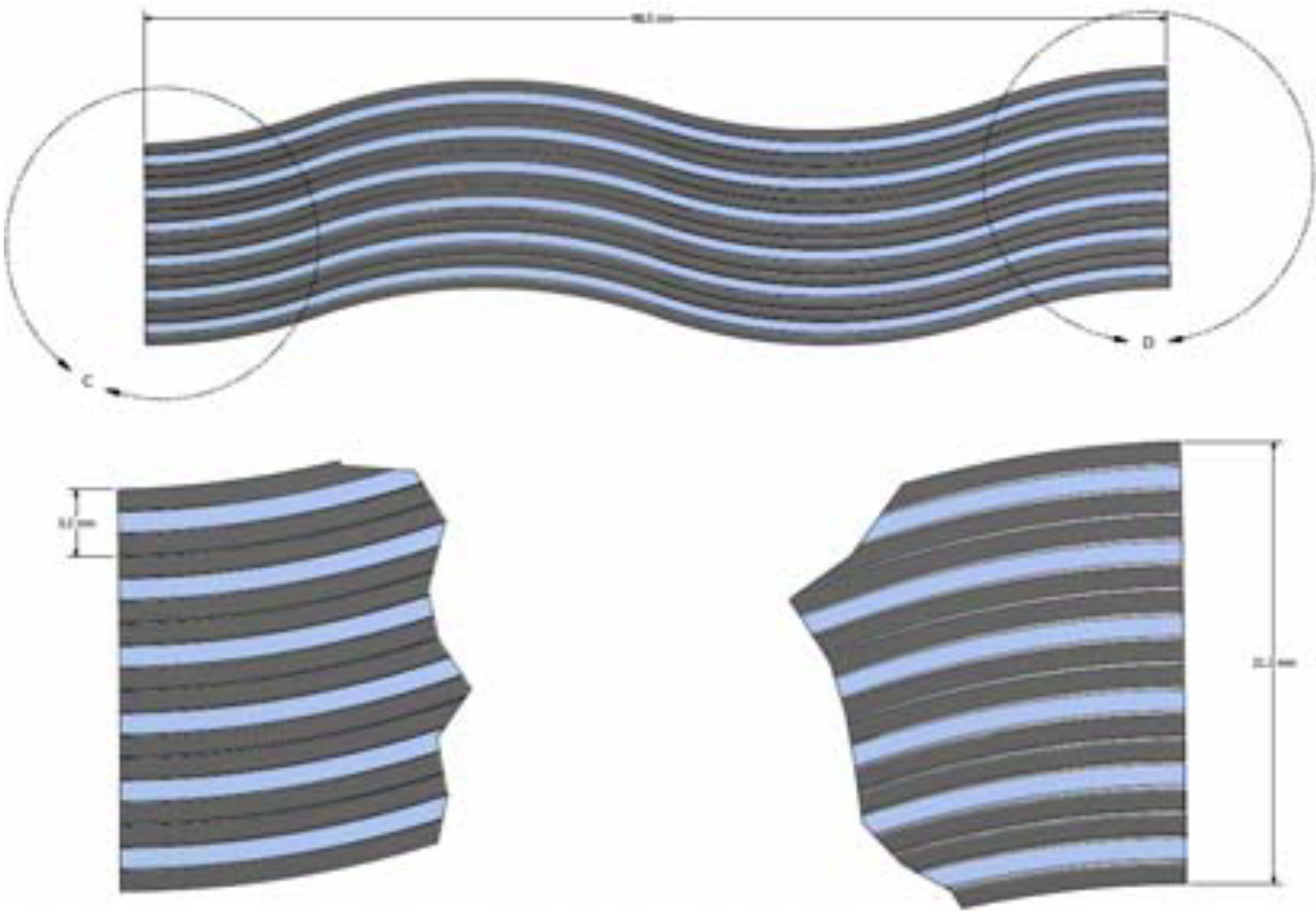

ACCORDION SANDWICH

# Always have an upgrade concept!

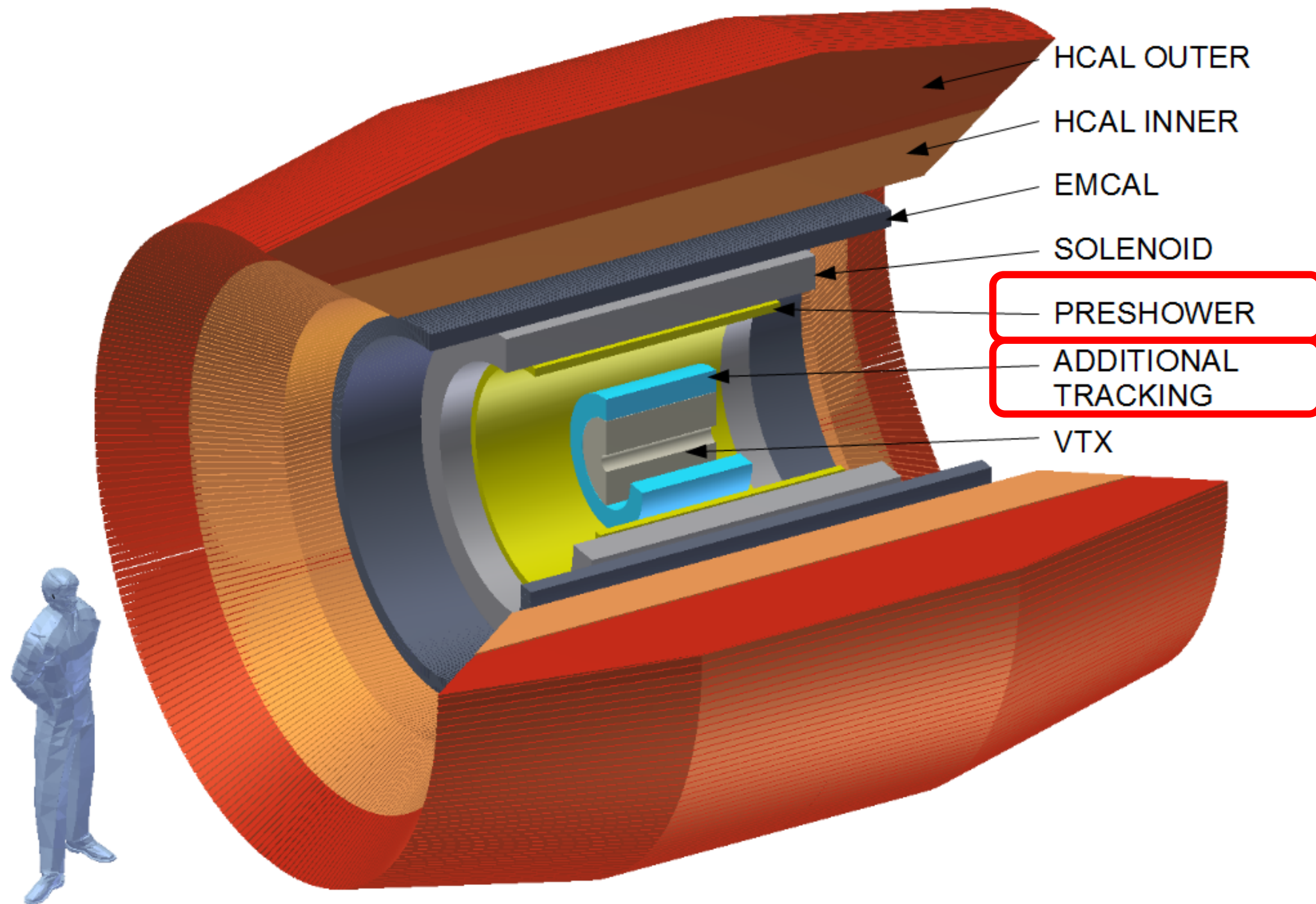

- EMCAL preshower
  - Upsilon
  - high  $p_T$   $\pi^0$   $R_{AA}$
  - improve direct  $\gamma$  and  $\gamma$ -jet
- Tracking upgrade
  - high  $p_T$  hadrons
  - modification of jets
  - heavy quark (b, c)

# Feedback from 2012 review

---

- Science case is strong, but ... would be stronger with those tracking upgrades

available. The Committee found that the tracking and preshower upgrades described in the appendices of the Conceptual Design Report represent a considerable improvement to the proposed detector capability. The entire proposal would be more compelling with the integration of these upgrades into the main body. The proposal should include a discussion of the existing VTX detector and the improvements when including the tracker plus preshower upgrades.

- Novel EMCAL design looks risky — you sure about that?
- Should consider 100% contingency (!) on magnet

Recent commercial procurements of superconducting magnets such as the proposed solenoid have proved problematic. Allowing only two years to design fabricate and test a solenoid such as this is marginal and therefore the sPHENIX collaboration should endeavor to acquire funding in advance of CD3 to initiate engineering. This would help to mitigate technical and cost risk.

**THREE  
WEEKS  
LATER...**

The screenshot shows a web browser window with the Science magazine website. The article title is "Italy Cancels €1 Billion Accelerator Project" by Edwin Cartlidge, dated 29 Nov 2012. The sub-headline reads "SuperB could be replaced by a smaller machine". The main text begins with "ROME—The Italian government has scrapped plans to build a particle accelerator known as SuperB in the outskirts of Rome after a new study calculated its total cost to be about €1 billion—some €350 million more than previously estimated."

Italy Cancels €1 Billion Accelerator Project

Science

News Home All News ScienceInsider News Features

HOME > NEWS > SCIENCEINSIDER > ITALY CANCELS €1 BILLION ACCELERATOR PROJECT

SCIENCEINSIDER | EUROPE

# Italy Cancels €1 Billion Accelerator Project

SuperB could be replaced by a smaller machine

29 NOV 2012 • BY [EDWIN CARTLIDGE](#)

**ROME**—The Italian government has scrapped plans to build a particle accelerator known as SuperB in the outskirts of Rome after a new study calculated its total cost to be about €1 billion—some €350 million more than previously estimated.

July 2013: DOE approves transfer of BaBar solenoid from SLAC to BNL

“Transfer Order Excess Personal Property”

STANDARD FORM 122 JUNE 1974 GENERAL SERVICES ADMINISTRATION FPMR (41 CFR) 101-32.306 FPMR (41 CFR) 101-43.315		<b>TRANSFER ORDER EXCESS PERSONAL PROPERTY</b>			1. ORDER NO.	
3. TO: GENERAL SERVICES ADMINISTRATION*						
5. HOLDING AGENCY (Name and address)* SLAC National Accelerator Laboratory 2575 Sand Hill Road, MS 85A Menlo Park, CA 94025						
7. LOCATION OF PROPERTY SLAC National Accelerator Laboratory C/O Mike Racine 2575 Sand Hill Road, MS 53 Menlo Park, CA 94025 650 926-3543 racine@slac.stanford.edu						
9. ORDERING AGENCY APPROVAL				10. APPROPRIATION SYMBOL AND TITLE		
A. SIGNATURE <i>[Signature]</i>		B. DATE 7-19-13		BNL to arrange for shipping transfer from DE-AC02-76SFO0515 transfer to DE-AC02-98CH10886		
C. TITLE <i>Property Manager</i>				11. ALLOTMENT		12. GOVERNMENT B/L NO.
13. PROPERTY ORDERED						
GSA AND HOLDING AGENCY NOS. (a)	ITEM NO. (b)	DESCRIPTION (Include noun name, FSC Group and Class, Condition Code and if available, National Stock Number) (c)	UNIT (d)	QUANTITY (e)	ACQUISITION COST	
					UNIT (f)	TOTAL (g)
	1	Administrative Transfer BaBar Solenoid and Components Date of Mfr: 1996 (See attached list)	ea	1	12,000,000.00	\$ 12,000,000.00
Total Acquisition Cost						\$ 12,000,000.00
Export Restriction Notice						
Personal property acquired/purchased from the U.S. Government may or may not be authorized for export/import from/into the country where the personal property is located. If export/import is allowed, the purchaser is solely responsible for obtaining required clearances or approvals. The purchaser also is required to pass on the Department of Energy's export control guidance if the property is resold or otherwise disposed.						
The use, disposition, export and re-export of this property are subject to all applicable U.S. laws and regulations, including the Atomic Energy Act of 1954, as amended; the Arms Export Control Act (22 U.S.C. 2751 et seq.); the Export Administration Act of 1979 as continued under the International Emergency Economic Powers Act (Title II of Pub. L. 95-223, 91Stat. 1626, October 28, 1977); Assistance to Foreign Atomic Energy Activities (10 CFR part 810); Export and Import of Nuclear Equipment and Material (10 CFR part 110); International Traffic in Arms Regulations (22 CFR parts 120 et seq.); Export Administration Regulations (15 CFR part 730 et seq.); Foreign Assets Control Regulations (31 CFR parts 500 et seq.); and the Espionage Act (37 U.S.C. 791 et seq.) which among other things, prohibit:						
(a) The making of false statements and concealment of any material information regarding the use or disposition, export or re-export of the property; and						
(b) Any use or disposition, export or re-export of the property which is not authorized in accordance with the provisions of this agreement.						
14. GSA APPROVAL		A. SIGNATURE		B. TITLE		C. DATE
SLAC APPROVAL		A. SIGNATURE <i>[Signature]</i>		B. TITLE Property Manager		C. DATE 7/18/2013
FOR GSA USE ONLY		AGENCY AND LOCATION		FSC	CONDITION	SOURCE CODE
		AGENCY STATE				

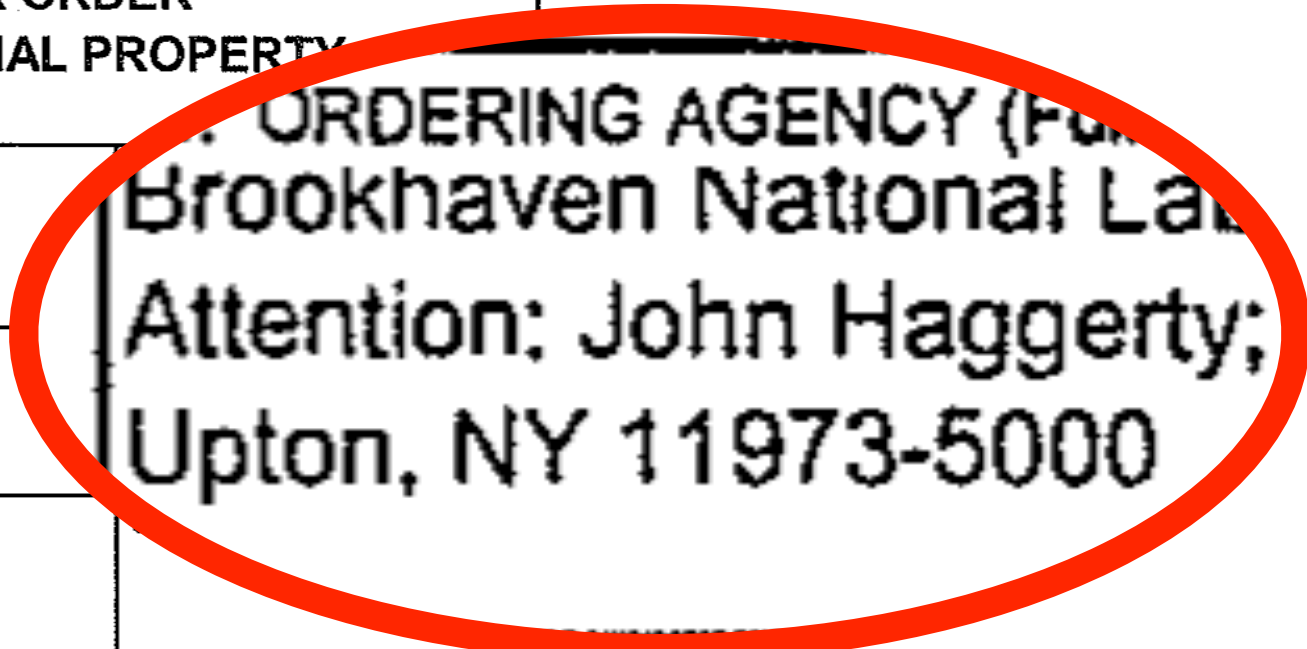

\*Include ZIP Code

sPHENIX ca. 2014

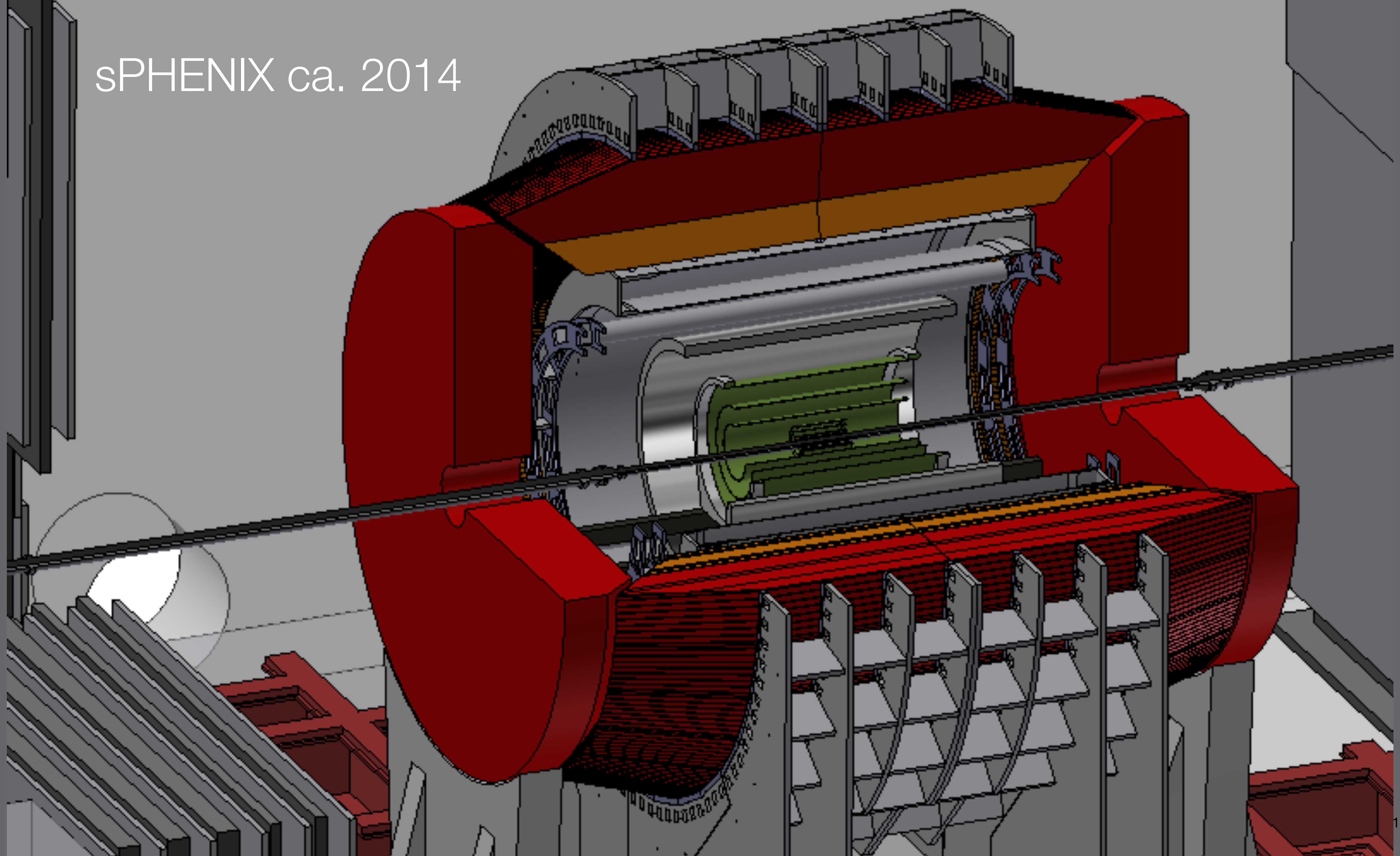

# Calorimeters reworked for BaBar solenoid

Scintillating fibers in W/epoxy matrix

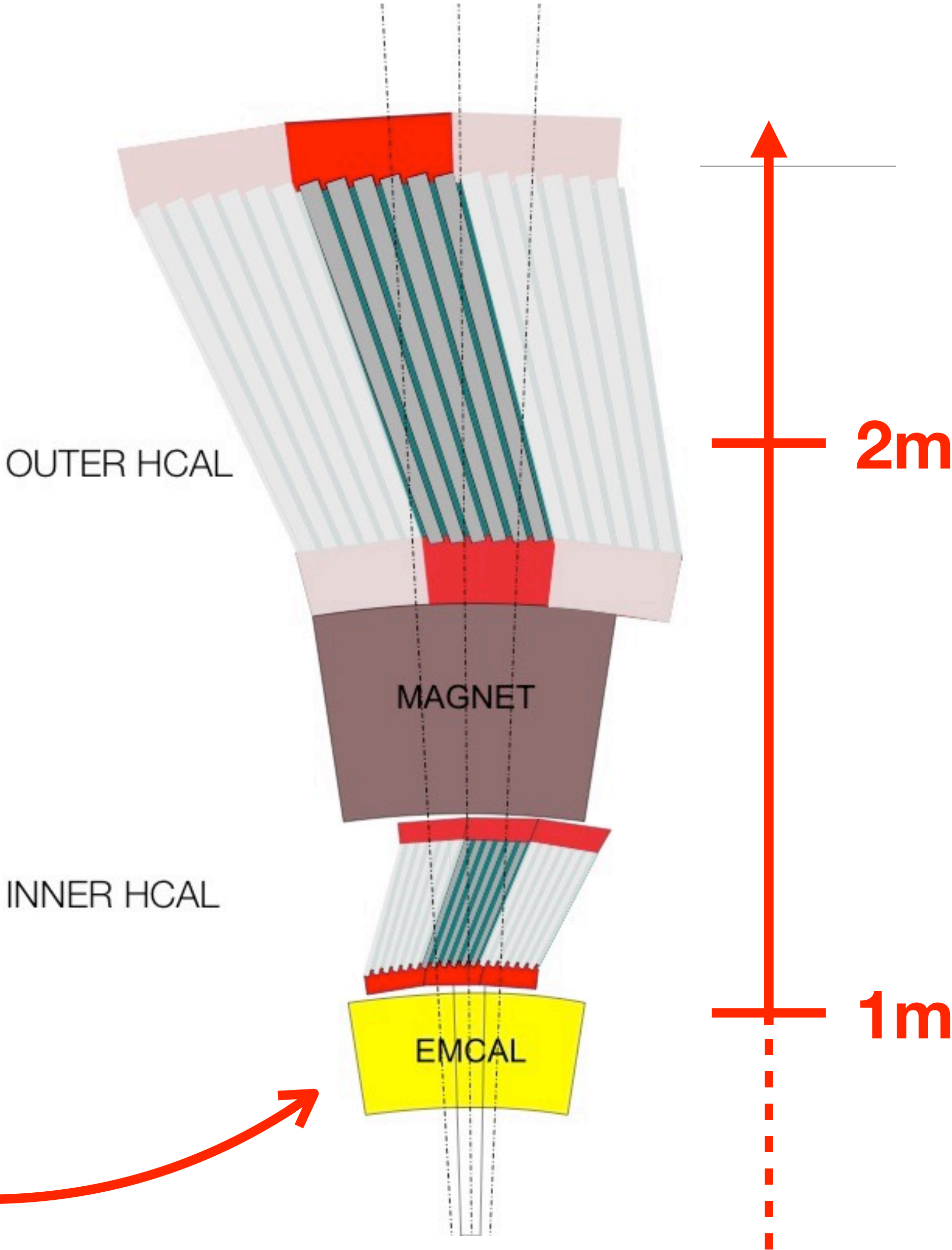
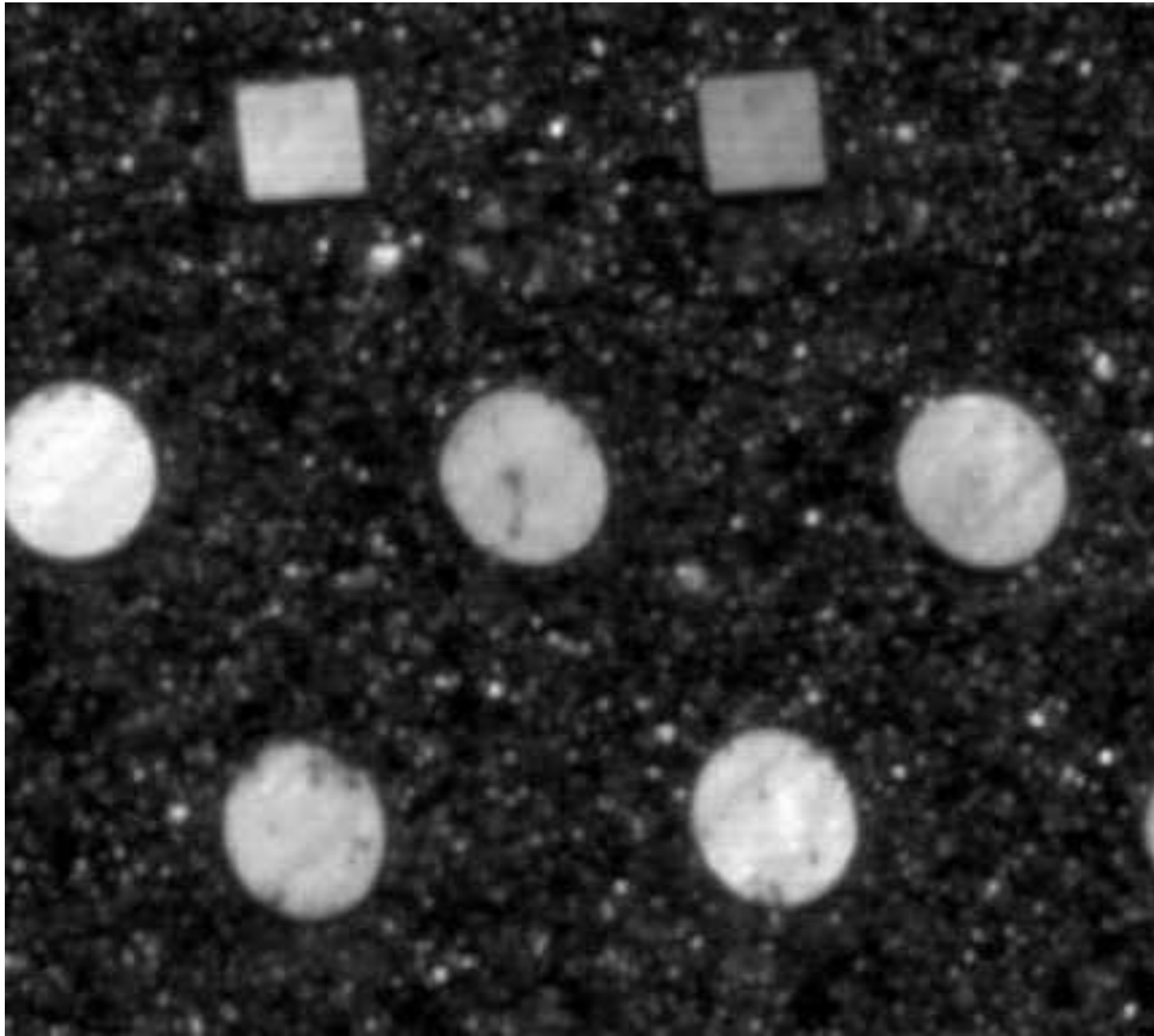

# Feedback from 2014 DOE CD-0 review

---

- Science case is still strong, but ... how about even better tracking?

The collaboration should explore all options to get the resolution for the  $Y$  measurement into the 100 MeV range. This may be achieved by improving the tracking and analysis techniques, but also by rearrangements of the hardware in the vertex tracker. Furthermore,  $Y$  statistics may be improved by recovering some of the events outside the  $\pm 10$  cm vertex cut or by triggering. An important priority for sPHENIX should also be the measurement of the transverse momentum dependence of the suppression. Care needs to be taken to get enough statistics for all three  $Y$  states also in pp collisions.

- No immediate CD-0 decision — we would hear about that two years hence

# QCD and Hadron Physics Town Hall, Temple University: September 2014

2014

## QCD and Hadron Physics

Summary of the DNP Town Meeting  
Temple University, 13-15 September 2014

Stanley J. Brodsky, Abhay L. Deshpande, Haiyan Gao, Robert D. McKeown,  
Curtis A. Meyer, Zein-Eddine Meziani, Richard G. Milner,  
Jianwei Qiu, David G. Richards, Craig D. Roberts

2/16/2015

### What jets studies at RHIC can tell us about QGP properties

Jamie Nagle  
University of Colorado



APS Division of Nuclear Physics: 2014 Long-range plan  
Joint Town Meetings on QCD  
Temple University  
September 13-15, 2014

Jamie Nagle

### How does QGP work?

- The open theory questions are still big. How best to see point-like scatterers? And, then, how best to operationalize the question of how the liquid emerges?
- Ideas to date focus on jet quenching phenomena, as they involve physics at varied scales. A Gaussian distribution of typical transverse momentum broadening arises in a strongly coupled liquid, or via point-like scatterers. A power-law tail in the distribution of rare harder transverse scattering can only come from point-like scatterers. Need to look for the scattering of moderate-momentum partons within a jet. Need precise measurements of how the medium modifies the angular distribution of those partons with a given momentum within a jet.
- First steps, both experiment and theory, have been taken. But only first steps. Need higher statistics dijet and gamma-jet data coming at the LHC. And, need to be able to compare the modification of the structure of jets at LHC and RHIC (sPHENIX). And, need new

Krishna Rajagopal

### A state-of-the-art jet detector at RHIC

Use consistent experimental approach at RHIC and LHC to provide lever arm from  $T \approx T_c$  to  $T \gg T_c$   
Study jet quenching vs medium temperature and density, parton  $p_T$ , flavor and pathlength

- to achieve a detailed characterization of QGP
- to understand how QGP properties arise from QCD

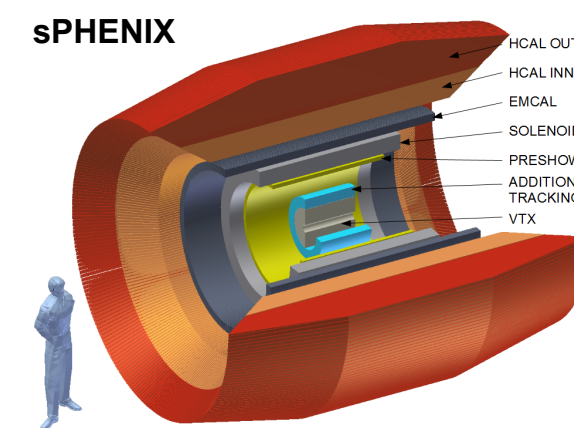

sPHENIX

Key capabilities

- Full calorimetry
- Tracking
- Rate capability to exploit luminosity ( $>50/\text{nb}$ ) and  $\sqrt{s}$  range (62-200 GeV) at RHIC

Mit Gunther Roland

Jets at

Gunther Roland

- Discussion was ... *robust*
- Not everyone wanted sPHENIX to specified in recommendations

## REACHING FOR THE HORIZON



The Site of the Wright Brothers' First Airplane Flight

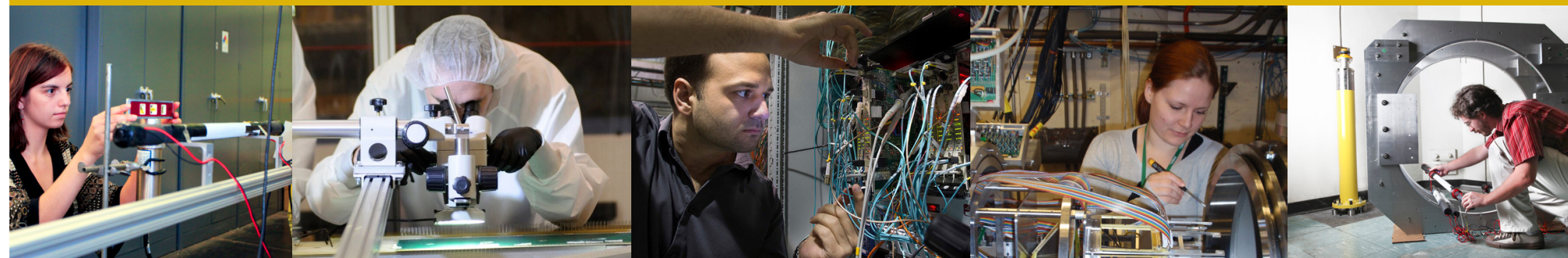

## The 2015 LONG RANGE PLAN for NUCLEAR SCIENCE



There are two central goals of measurements planned at RHIC, as it completes its scientific mission, and at the LHC: **(1) Probe the inner workings of QGP by resolving its properties at shorter and shorter length scales. The complementarity of the two facilities is essential to this goal, as is a state-of-the-art jet detector at RHIC, called sPHENIX. (2) Map the phase diagram of QCD with experiments planned at RHIC.**

January 2015: magnet begins its commute down I-280



# Forming a collaboration

## December 2015

---

- ALD Berndt Mueller asked John Harris (Yale, STAR & ALICE) to lead the process.
- 70 participants — not all of them from PHENIX — met at Rutgers University.
- Gunther Roland (MIT), DPM elected co-spokespersons.



## *Welcome to the sPHENIX – “New RHIC Detector” Collaboration Meeting*

John Harris  
Yale University

CD-0 approval September 2016

Yay! We're all set!

... uh, hardly.

**Mission Need Statement  
for an Upgrade to the  
Pioneering High Energy Nuclear Interaction  
eXperiment (PHENIX)  
known as Super PHENIX (sPHENIX)  
as a Major Item of Equipment**

**Non-Major Systems Acquisition**

**Office of Nuclear Physics  
Office of Science  
U.S. Department of Energy**

**Date Approved:  
September 2016**

Descoping: identify what you **must** have, impact the science as little as possible, keeping in mind a strategy for recovery



sPH-GEN-2017-002

## sPHENIX MIE Cost Range and sPHENIX Scope

The sPHENIX Collaboration  
November 3, 2017

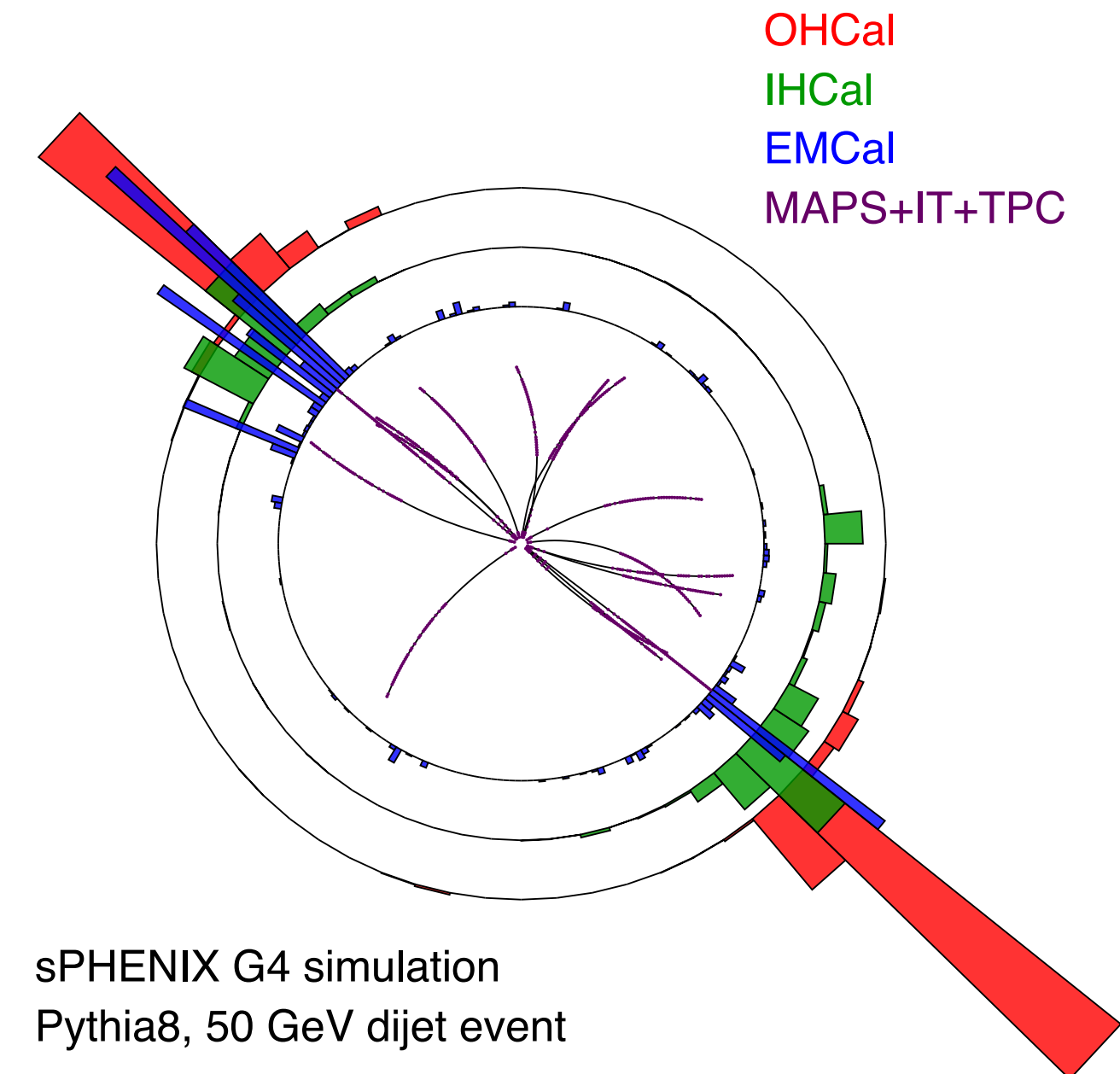

Project Director: O'Brien  
Project Scientist: Haggerty  
Project Engineer: Mills  
Project Controls: Young, Sourikova, Lavelle

Recovering scope was top priority. Add scope to maximize science.

---

Collaborating institutions: Fudan Univ., Peking Univ., CIAE took on scope of high- $\eta$  EMCal towers!

RIKEN contributed INTT

BNL capital projects:  
MVTX, inner HCal

BNL + Saclay, MIT, LANL:  
TPOT

NSF funded the event  
plane detector via Lehigh

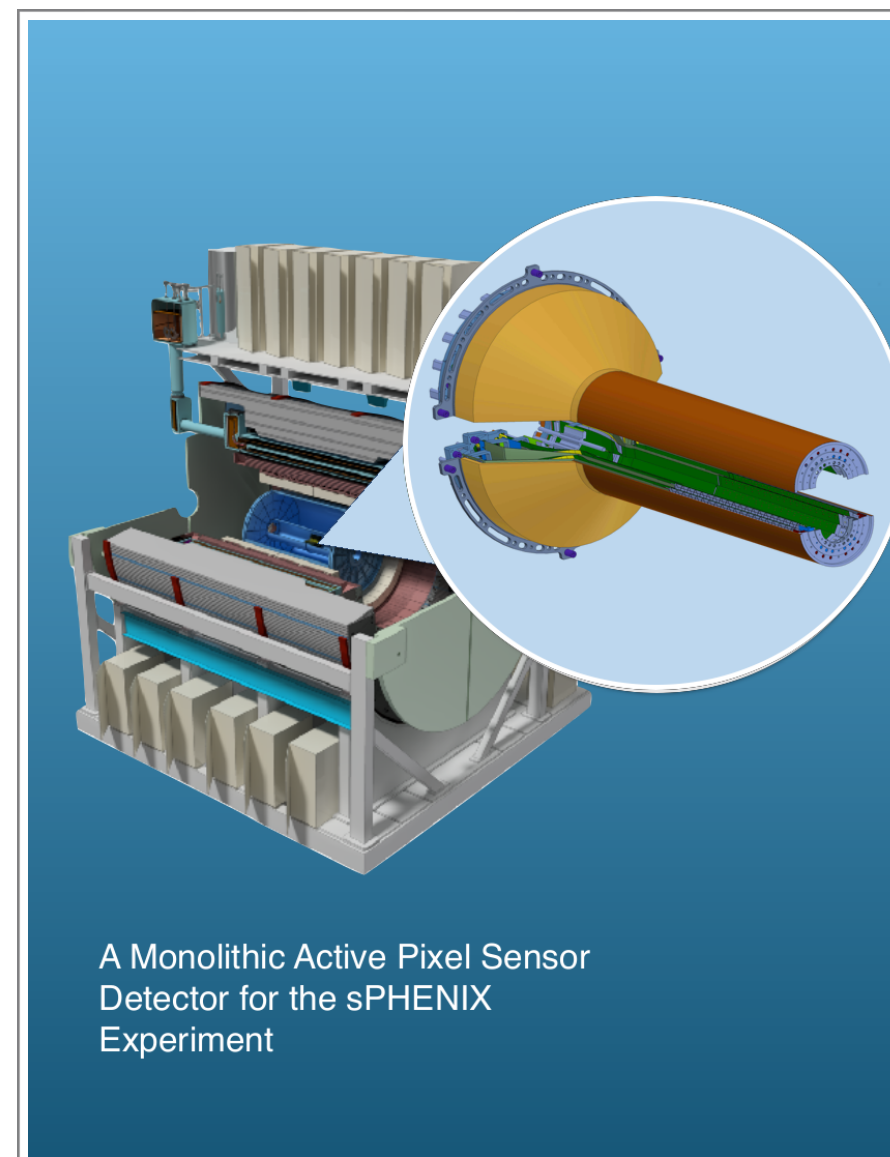

MAPS proposal

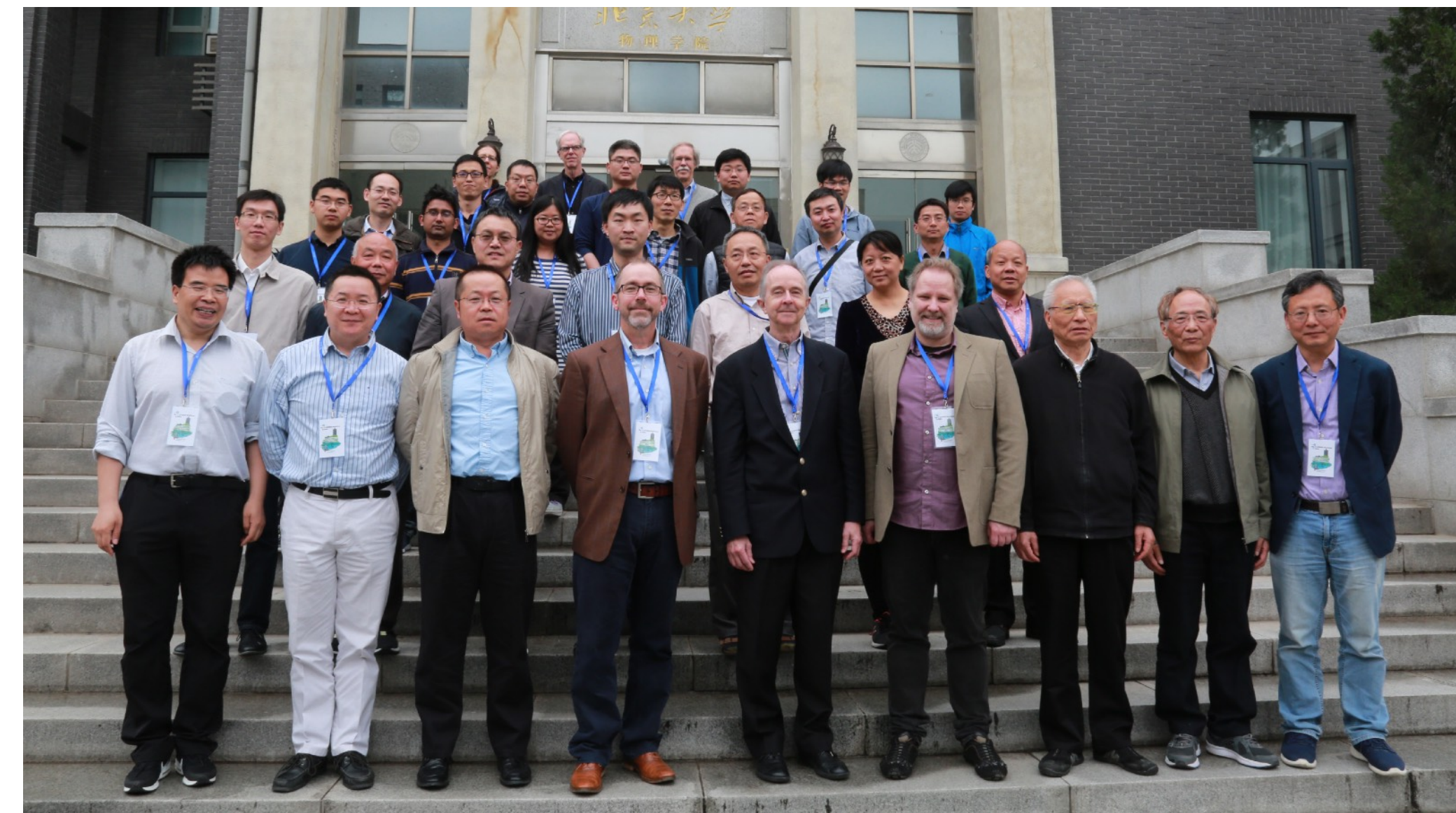

“The First sPHENIX Workshop in China,” at  
Peking University, Beijing, April 22-23, 2018

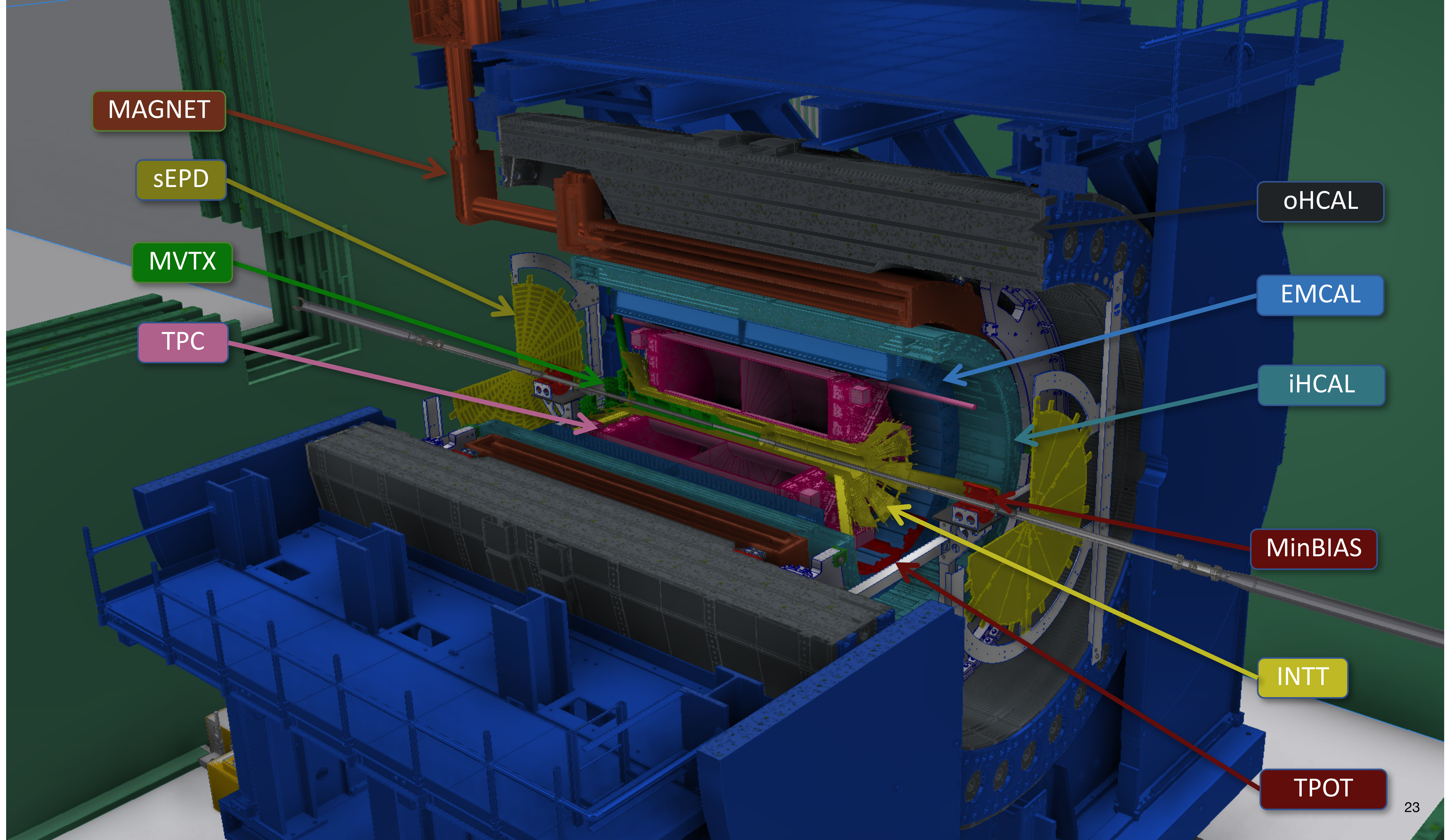

MAGNET

sEPD

MVTX

TPC

oHCAL

EMCAL

iHCAL

MinBIAS

INTT

TPOT

# Everything, everywhere, all at once — our Indico has 5600 meetings

- **TPC** at VU, WU, Wayne St., SBU, Lund
- **EMCal** at UIUC, Fudan, Peking, CIAE
- **oHCal** at GSU, BNL
- **iHCal** at ISU, BNL
- **INTT** at BNL, RIKEN, Purdue, NCU, NTU, NWU
- **sEPD** at Lehigh, CU
- **TPOT** at Saclay, BNL, LANL
- **MVTX** at CERN, LBNL, MIT, LANL
- **MBD** at BNL





I'm not superstitious, but ...





Recent Russian offensive operations along the Black Sea coast have forced at least two of the three major Ukrainian air-separation firms (Cryoin and Ingas) to **shutter their operations** in Odesa and Mariupol, halting a significant portion of the world's noble gas exports. Ukraine is **the world's largest supplier** of noble gases including neon, krypton, and xenon. **Globally, Ukraine supplies about 70% of the world's neon gas and 40% of the global krypton supply. Moreover, Ukraine supplies 90% of the highly purified, semiconductor-grade neon for chip production used by U.S. industry. China, Japan, and South Africa are among the other major suppliers of neon.**

Original TPC gas: Neon + CF<sub>4</sub>

# Fire damages UPS warehouse in Lancaster

by [The AV Times Staff](#) • April 11, 2022



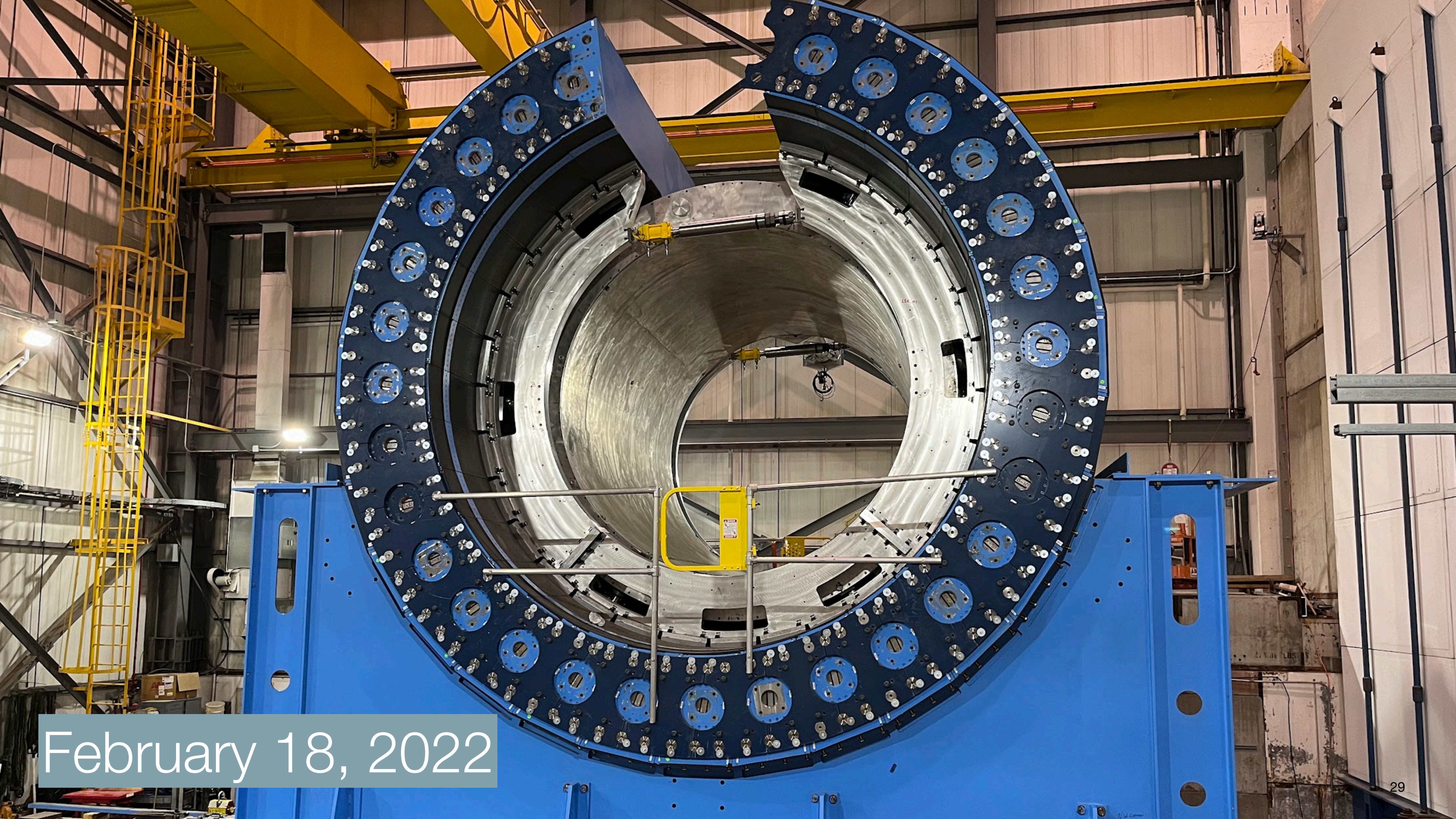

February 18, 2022



原子核物理学 “Primordial Soup”

## 加速器実験で探る 「強い力」 クォーク・グルーオン・プラズマを作る

“素粒子のスープ” だった誕生直後の宇宙を  
かつてないほど精密に解き明かす実験が始まる

C. モスコウィッツ (SCIENTIFIC AMERICAN 編集部)

Photographs by Christopher Payne

原子を観察できる顕微鏡を持っているとしよう。そして、最も小さな原子である水素原子を詳しく見てみる。外縁を飛び回っている1個の電子を横目にさらに拡大していくと、原子核が見えてくる。水素原子のこの場合は1個の陽子だ。高校の物理では、陽子はクォークという素粒子が3個（2個のアップクォークと1個のダウンクォーク）集まってできたものであると教わる。しかし、実際には陽子をはるかに複雑であり、その内部構造や、陽子の質量やスピンといった性質が陽子を構成している粒子の性質にどう由来しているのかはまだ明らかになっていない。

陽子内部の模式図に描かれる3個のクォークは単に「価クォーク」(91ページの訳者ノート1を参照)にすぎず、クォークや反クォーク（クォークの反物質）、さらにはそれをつなぐ糊「グルーオン」の海を漂うパイのようなものだ。陽子の中のクォークとグルーオ

ンの総数は絶えず変化している。クォークと反クォークの対が常に生成と消滅を繰り返しており、グルーオンは、特に陽子が高速で運動している（大きな運動エネルギーを持っている）場合に分裂・増殖しやすい。要するに、陽子の構造は混沌としている。自然界の4つの基本的な力のうち最も強い「強い力」はこの雑然とした粒子たちを陽子（と中性子）の中に閉じ込めている。だが、そうではない状況もある。

ビッグバンの直後、宇宙はあまりに高温・高密度で、強い力はクォークやグルーオンを閉じ込めておくことができなかった。代わりに、それらは「クォーク・グルーオン・プラズマ」と呼ばれるほとんど抵抗なくサラサラと流れる大海原をなしていた。この段階は宇宙史におけるほんの瞬間から約10億年たった。グルーオンは閉じ込められなかった。しか

億年後の今、物理学者は加速器によってこのクォーク・グルーオン・プラズマを再現できるようになった。大きな原子核（金の原子核など）を2個用意し、光速に近い速度まで加速して正面衝突させる。衝突によってクォーク・グルーオン・プラズマの“しずく”ができるのに十分な温度と圧力を作り出すのだ。ただし、このしずくはすぐに散り散りになり崩壊してしまう。

この衝突を捉える装置はそびえ立つ建造物であり、同心円状に配置された多くの検出器などの機器やそれをつなぐ何千ものケーブルからなる。昨年、私はニューヨーク州ロングアイランド

国立ブルックヘブン研究所（ニューヨーク州ロ

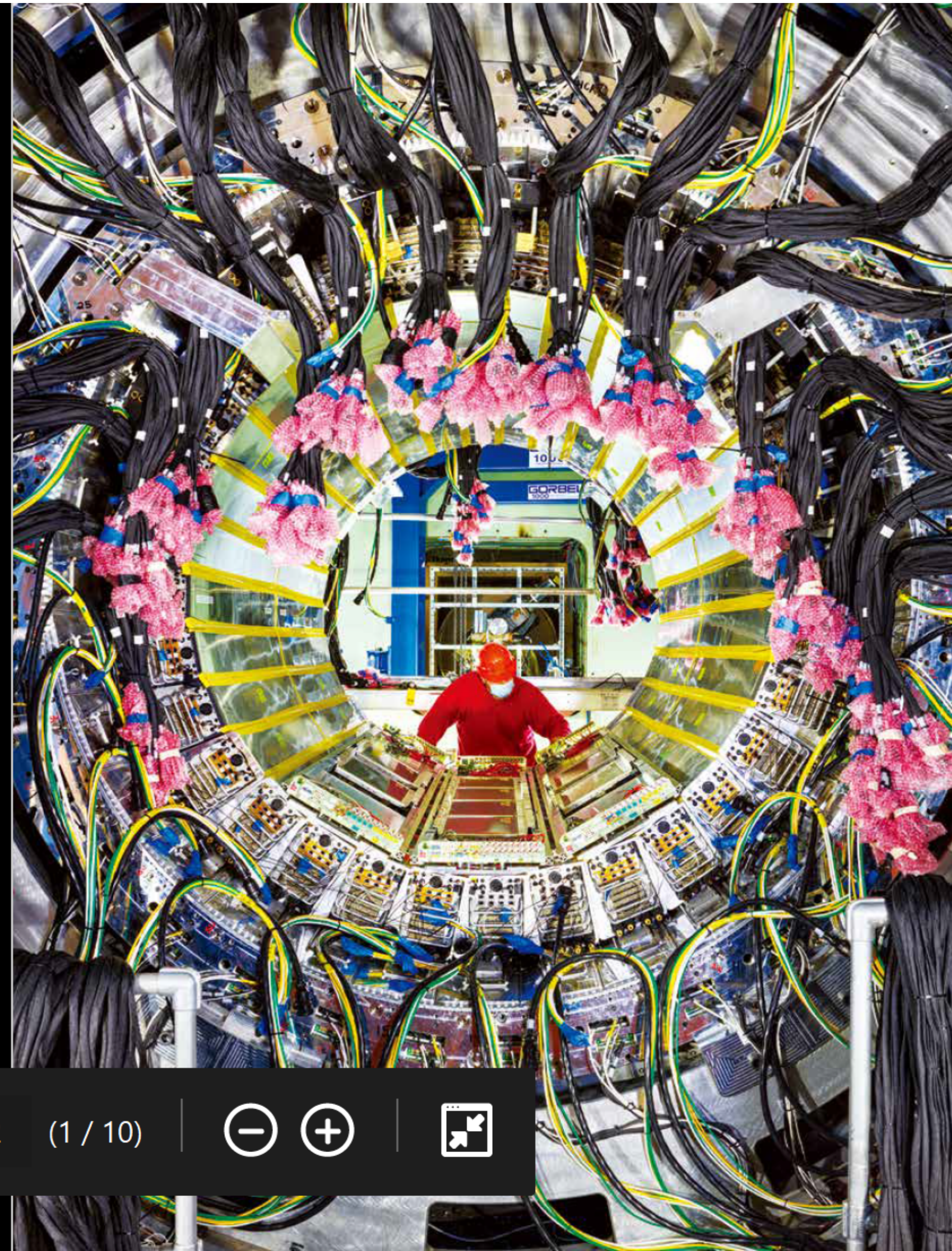

82

(1 / 10)



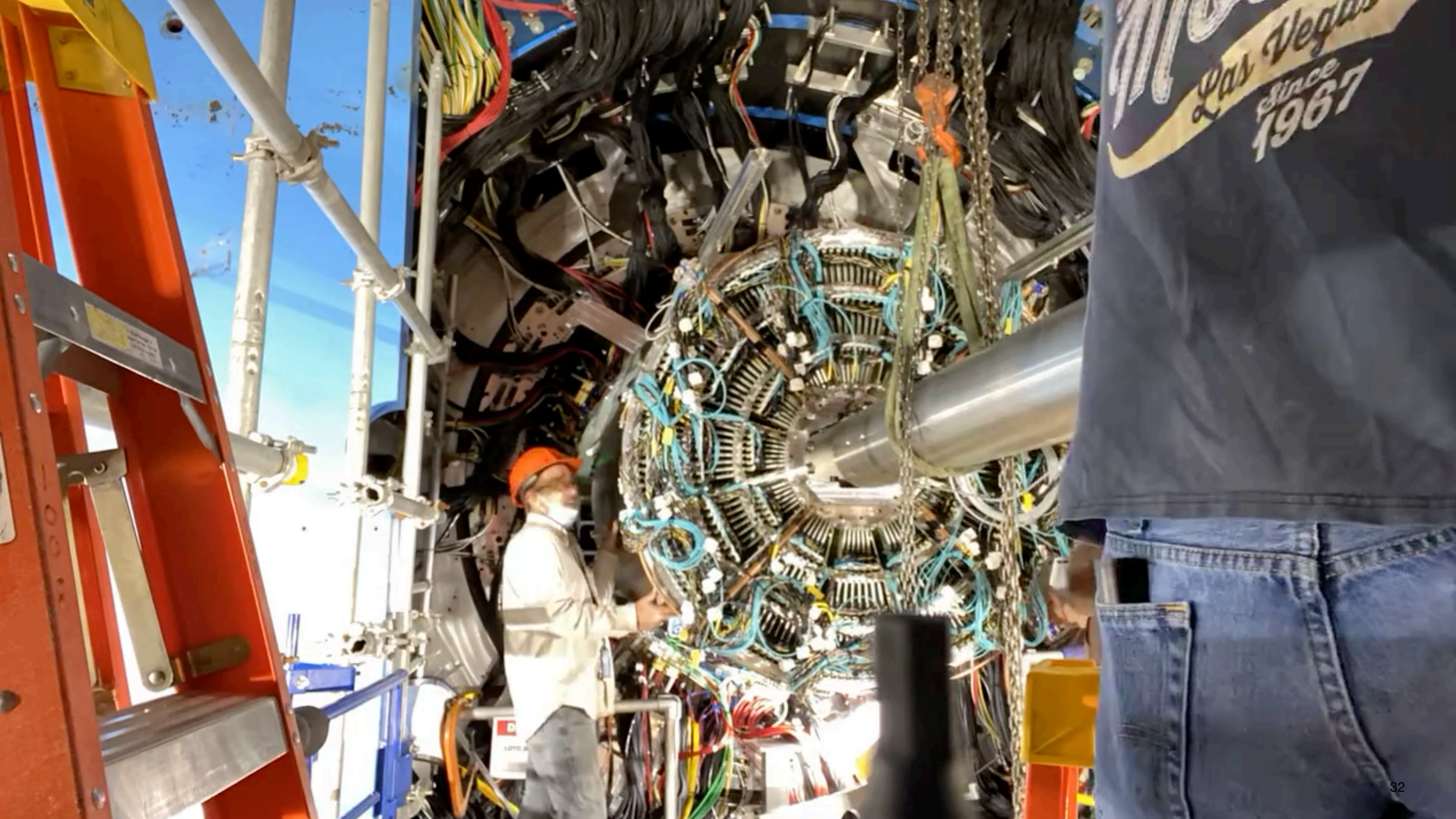

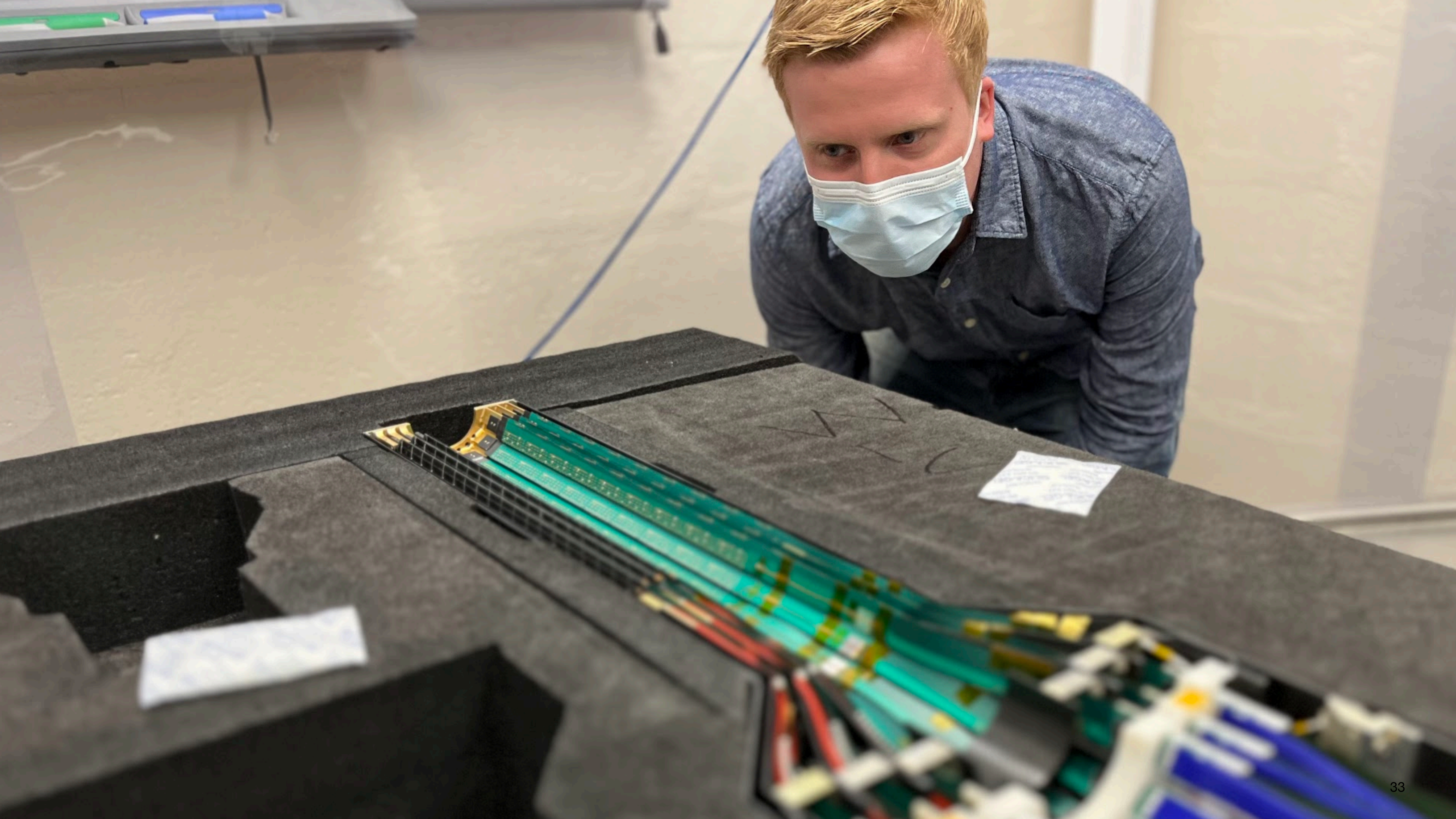

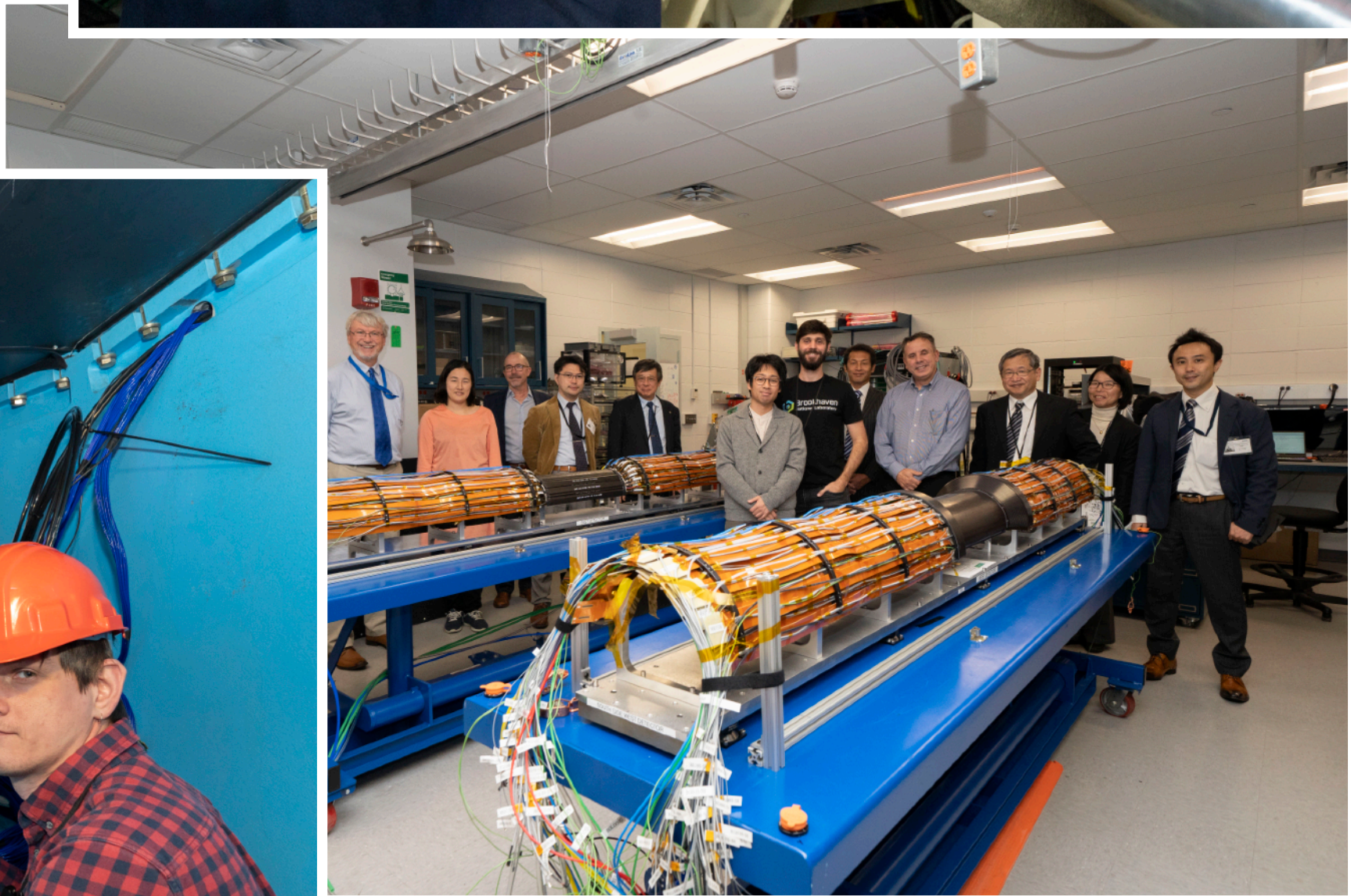

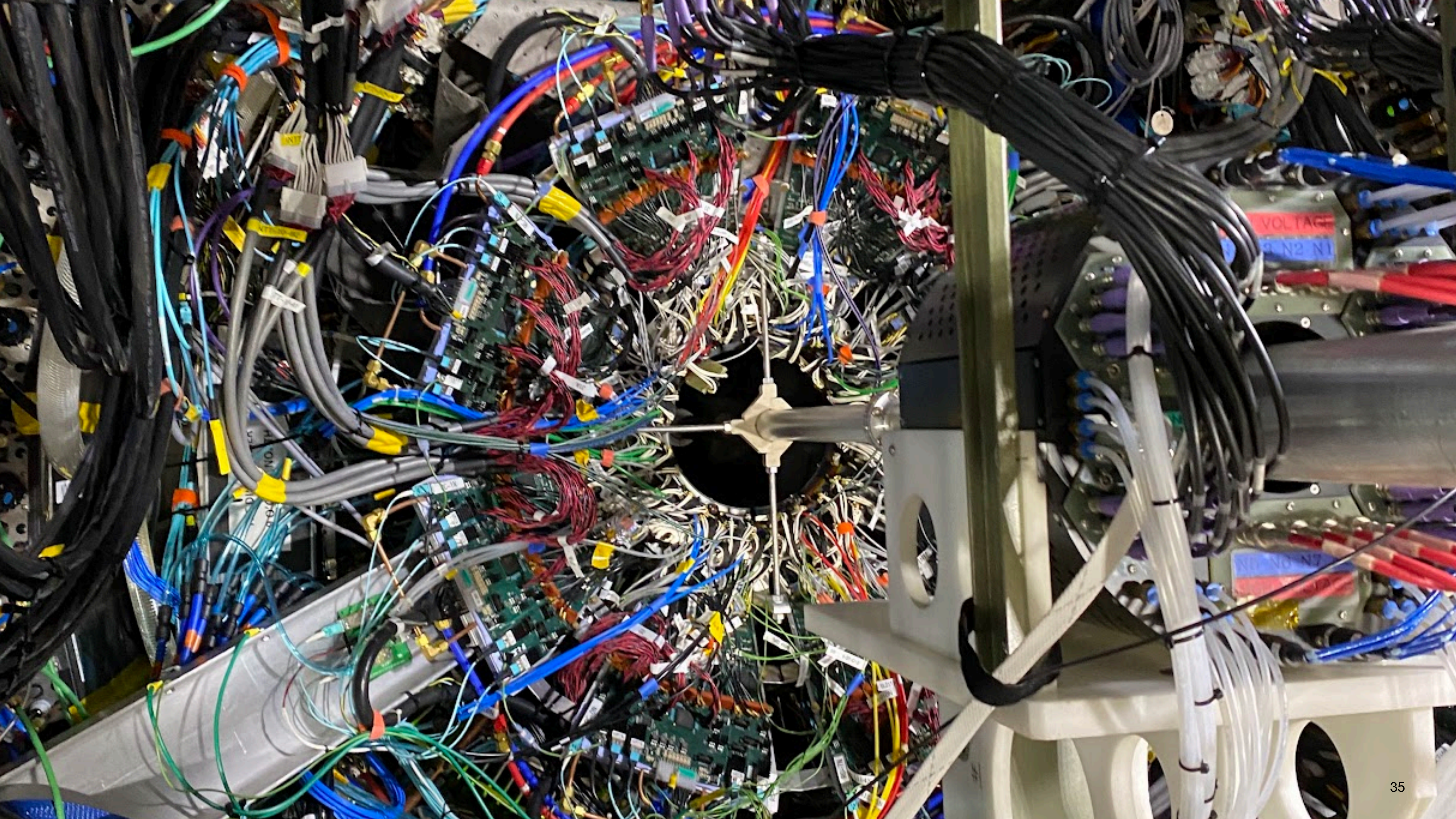

# Into the home stretch: “Approval to Operate”

- Major focus was safety: documentation, procedures, interviewing shift crews, electrical code inspections, signage & labeling, hand rails, walking surfaces
- For some of us, unfamiliar review territory — about nine weeks to complete
- Received approval from Brookhaven DOE site office on May 18 — fantastic!

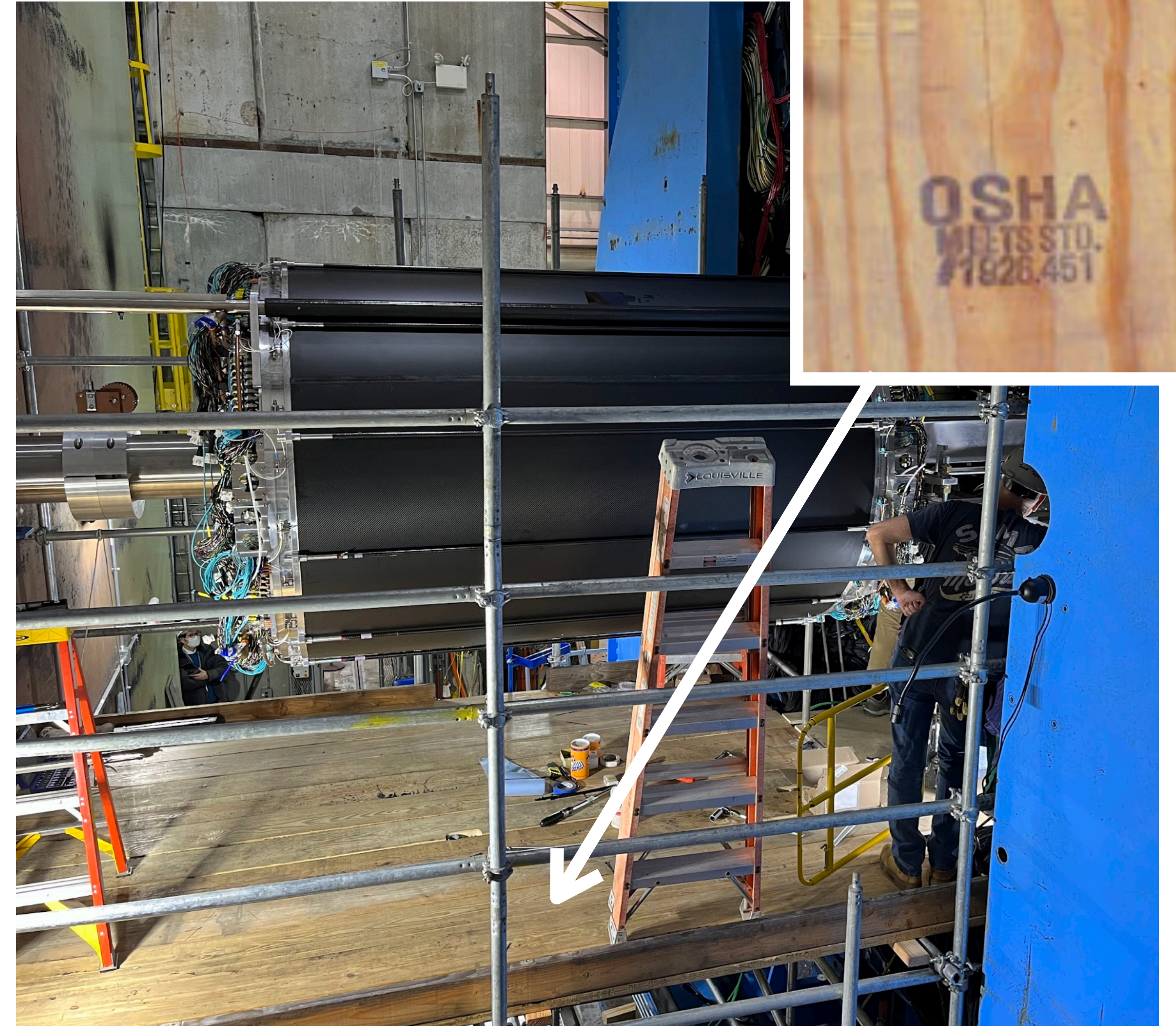



sPHENIX control room

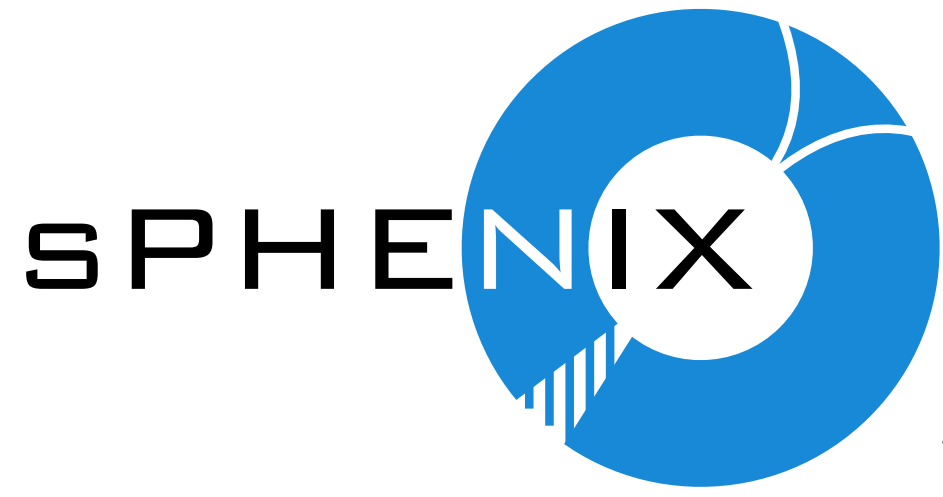

## from concept to commissioning

---

- To do interesting things at scale, you need help from a lot of friends!
  - DOE (NP and site office) and NSF and IKC
  - BNL — capital projects, facilities, scientific, technical, and trades
  - sPHENIX collaborators and their institutions did amazing things!
- Unusual opportunity for students, postdocs to learn, contribute, lead
- Leaving you on the threshold of sPHENIX operations!

# Pondering an EIC future ...

In 2013, ALD Berndt Mueller charged STAR and PHENIX to develop EIC detector LOIs

Review panel for PHENIX LOI

→ **Sam Aronson (BNL)**  
Krishna Kumar (UMass-Amherst)  
Jianwei Qiu (BNL)  
Veljko Radeka (BNL)  
Paul Reimer (ANL)  
Jim Thomas (LBNL)  
Glenn Young (JLab)

Concept for an Electron Ion Collider (EIC) detector built around the BaBar solenoid

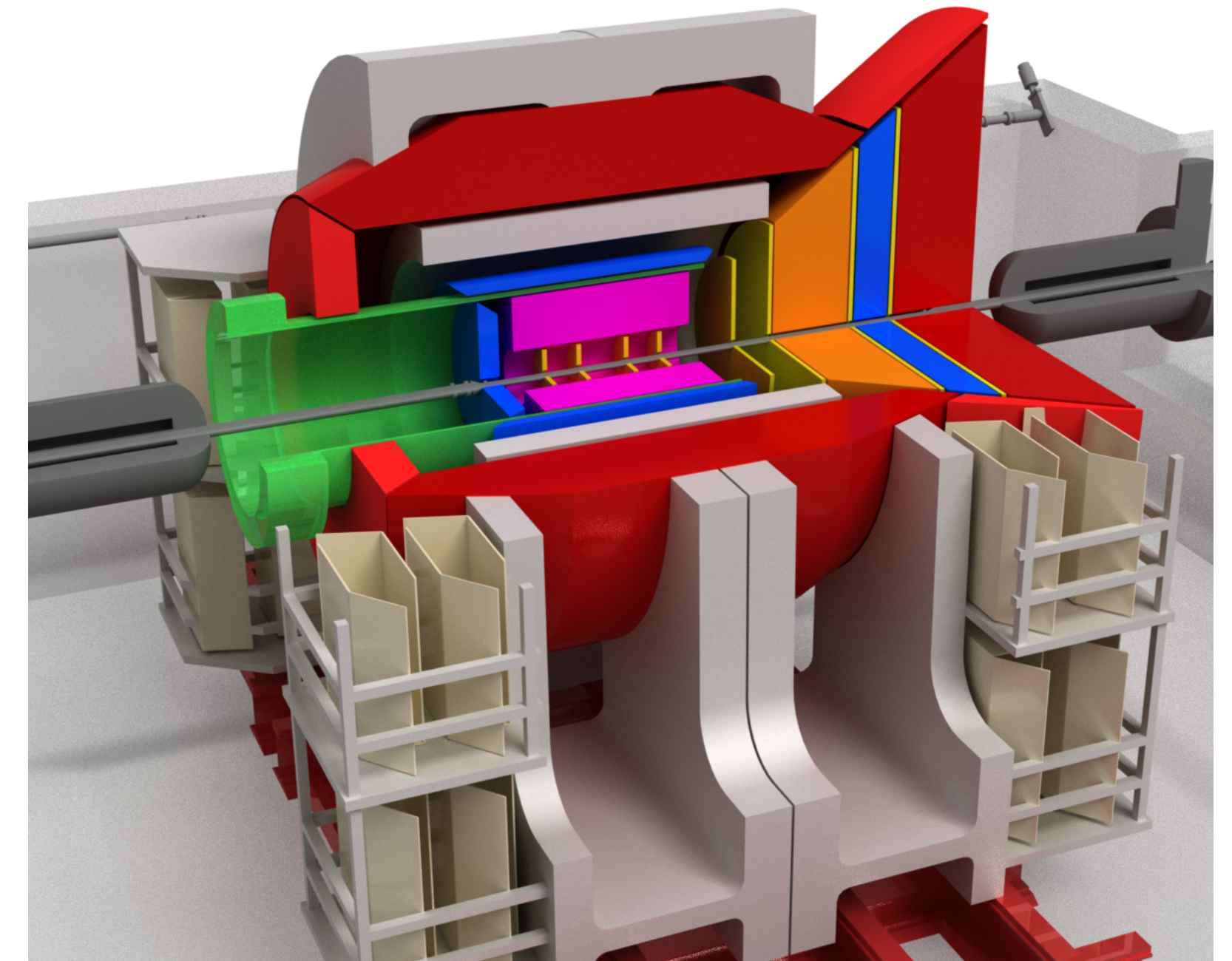

arXiv:1402.1209v1 [nucl-ex] 5 Feb 2014

The PHENIX Collaboration  
February 3, 2014