

Single processing check in PDVD

Xuyang Ning

Pochoir

https://github.com/brettviren/pochoir/tree/confings_and_instructions

Domain:

In general define the shape of arrays and spacing;
the array can be values of boundary, voltage,
potential, velocity...

3D drift field



drift velocity;
electron drift path



2D weighting field
3D weighting field
separate for u v
and w planes



final result:
induced current

Solve 1st Maxwell equation on a 3D
lattice both for the drift field
and the weighting field using Finite
Difference Method (FDM)

Iteratively solved for
whole simulated
volume

$$V_0 = \frac{(V_{x+} + V_{x-} + V_{y+} + V_{y-} + V_{z+} + V_{z-})}{6}$$

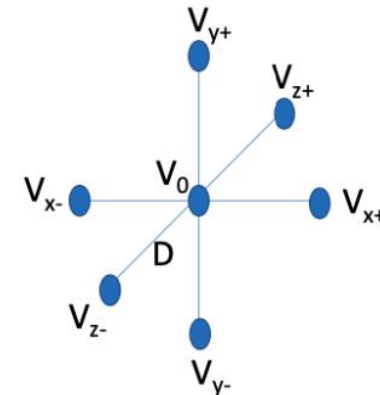

3D Drift field

Minimal symmetry for Drift Field

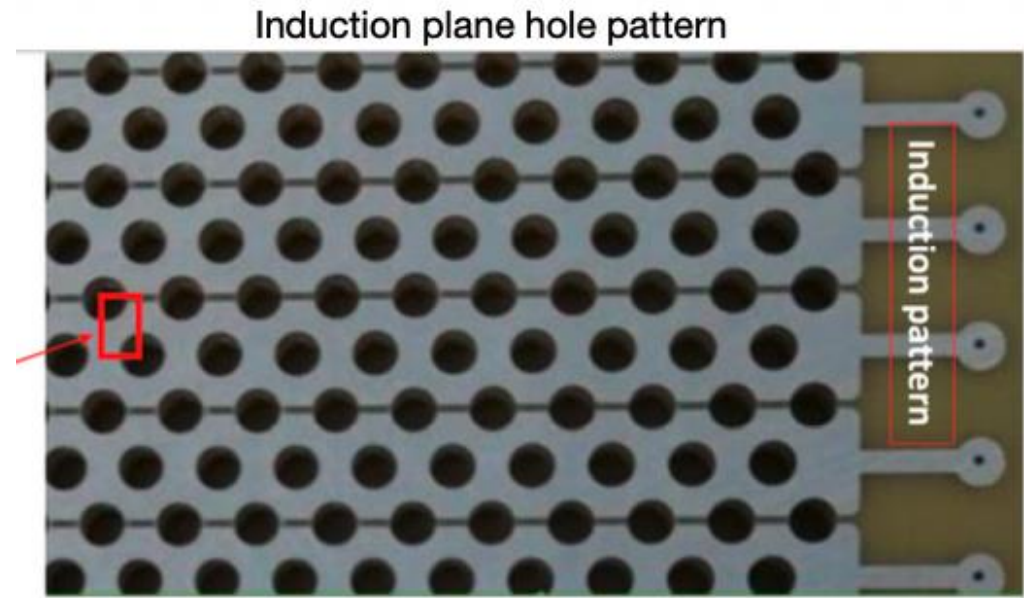
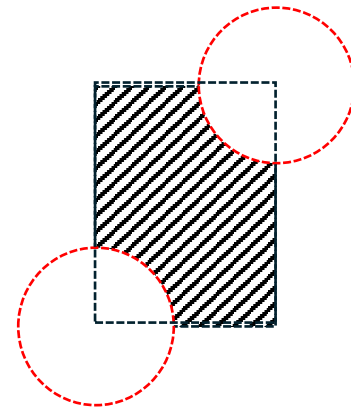
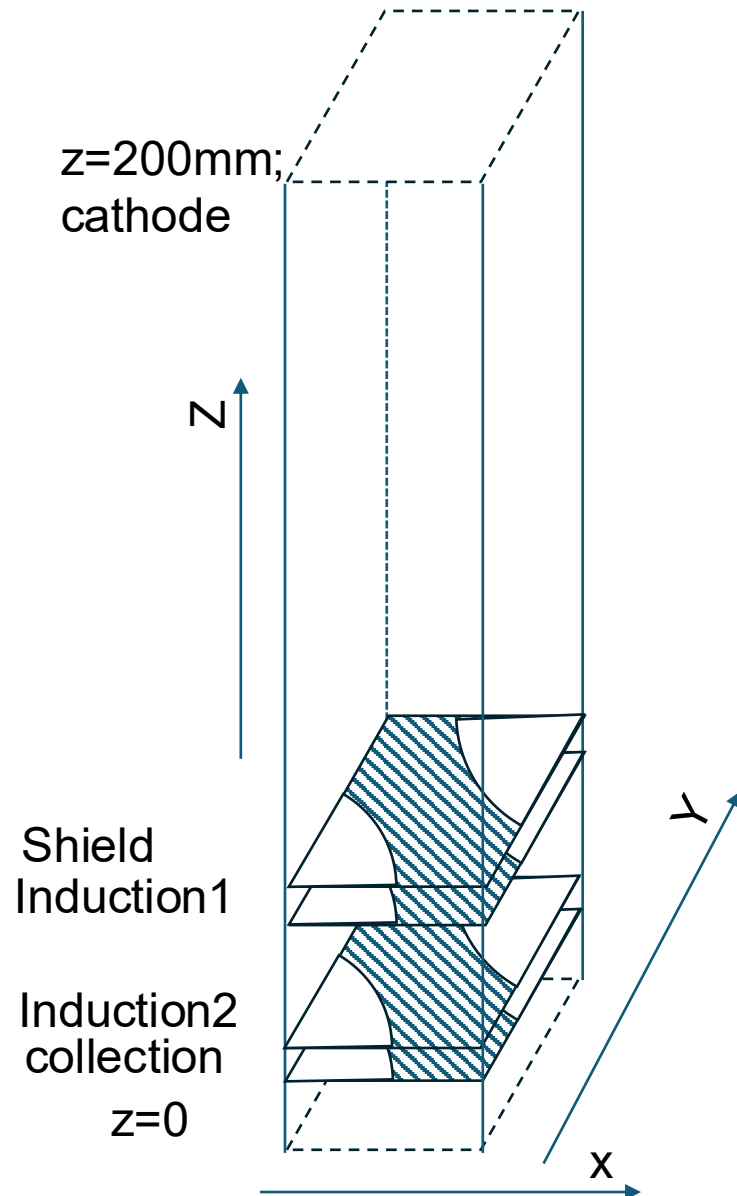

PCB Quarter 30deg - Boundary

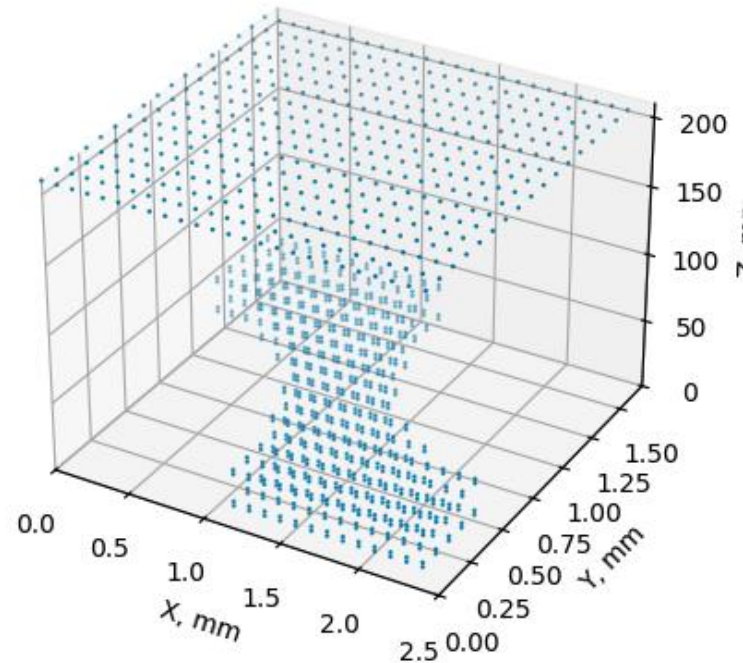

2 arrays to describe:
one for boundary;
one for voltage.

Then solved by FDM.

2D weighting field

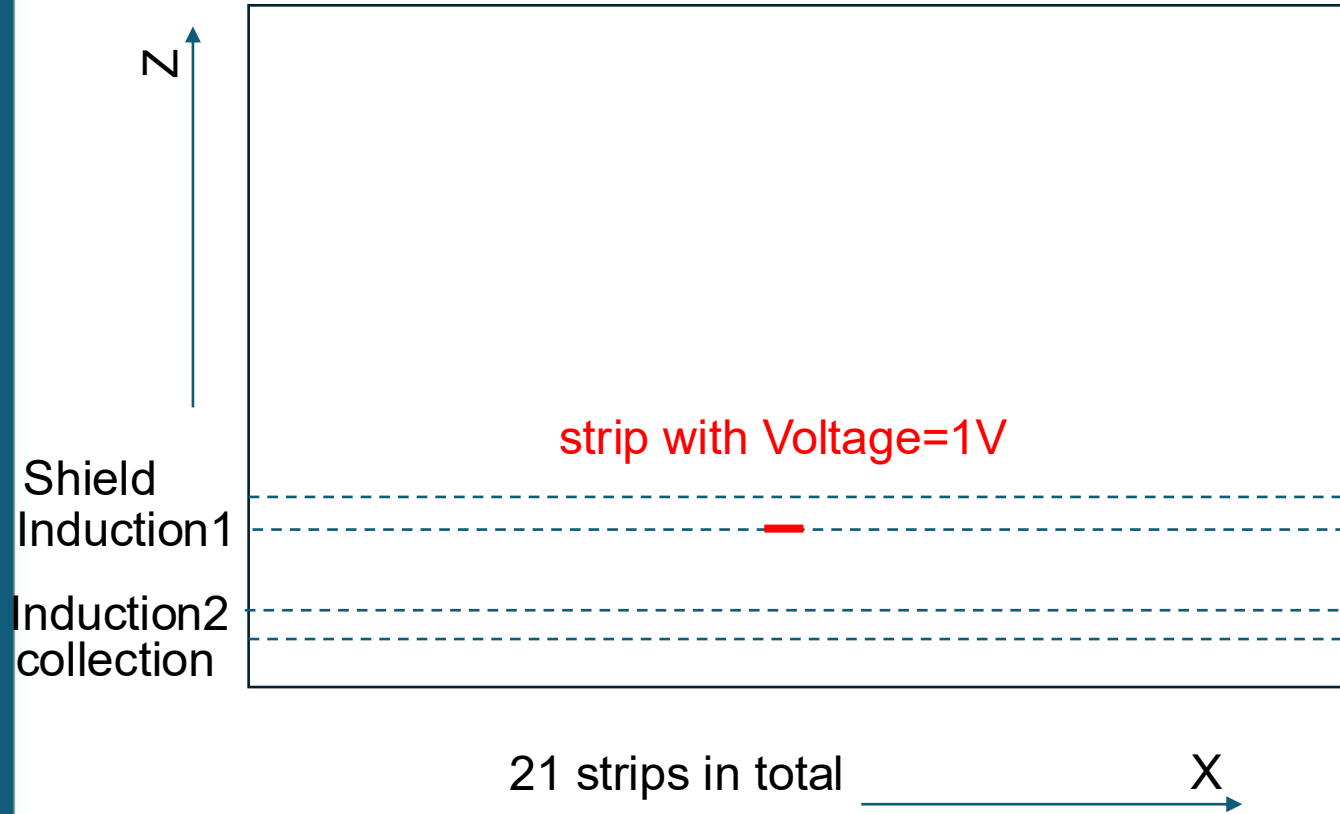

⊗, strip direction

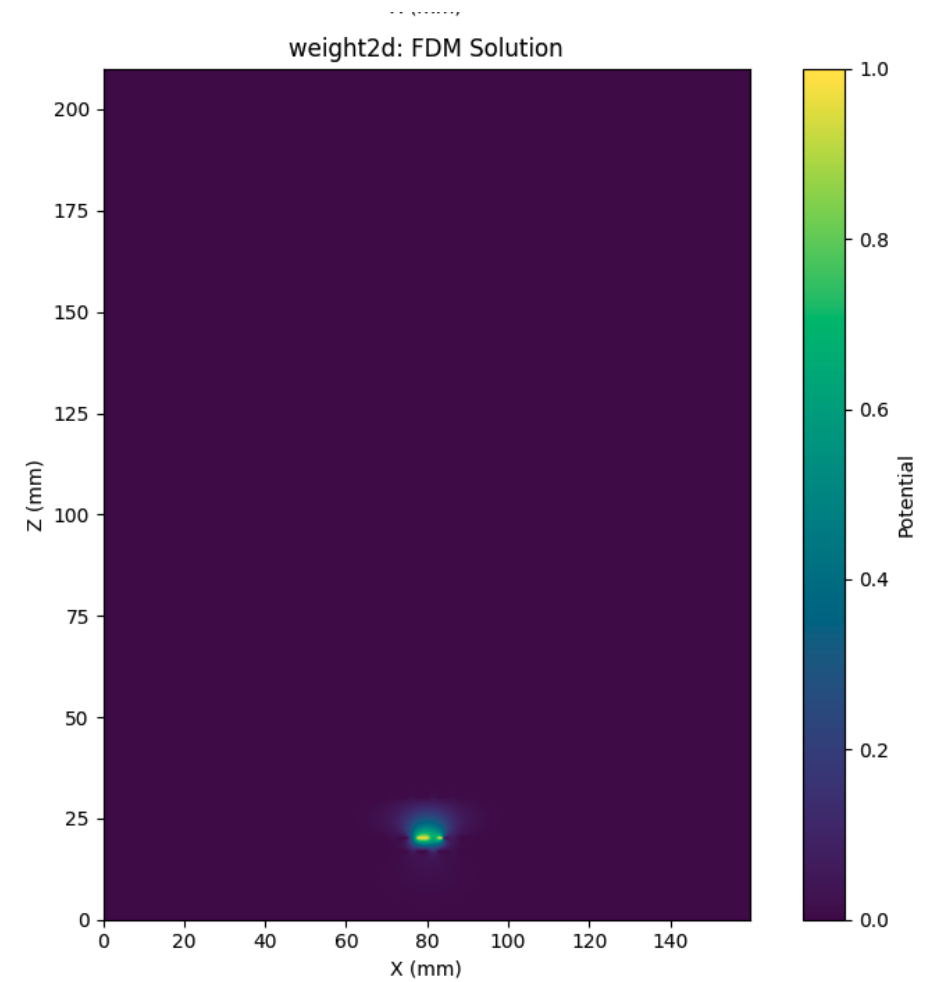

3D weighting field

⊗, strip direction

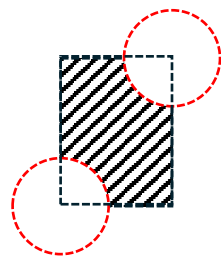

W plane:

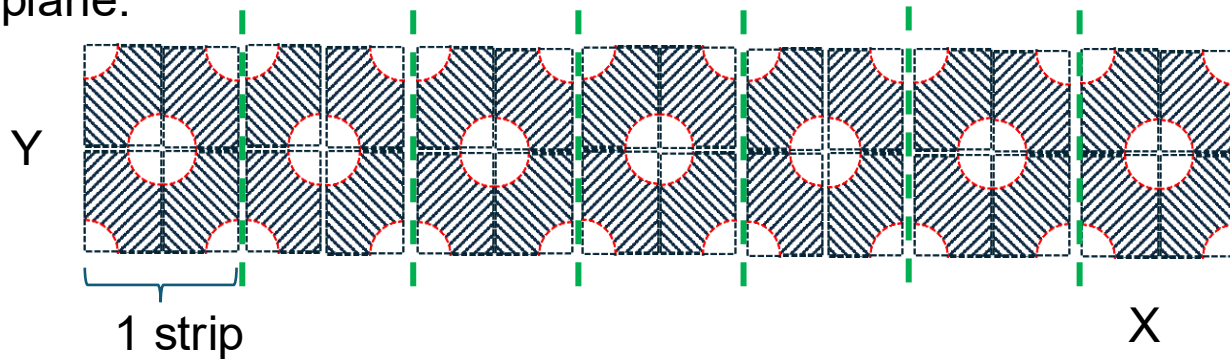

U/V plane:

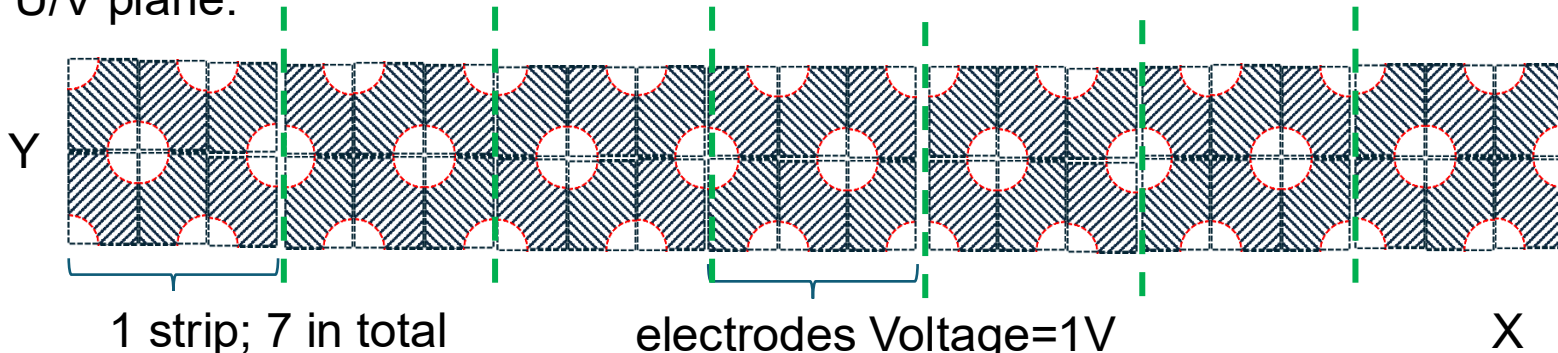

Z

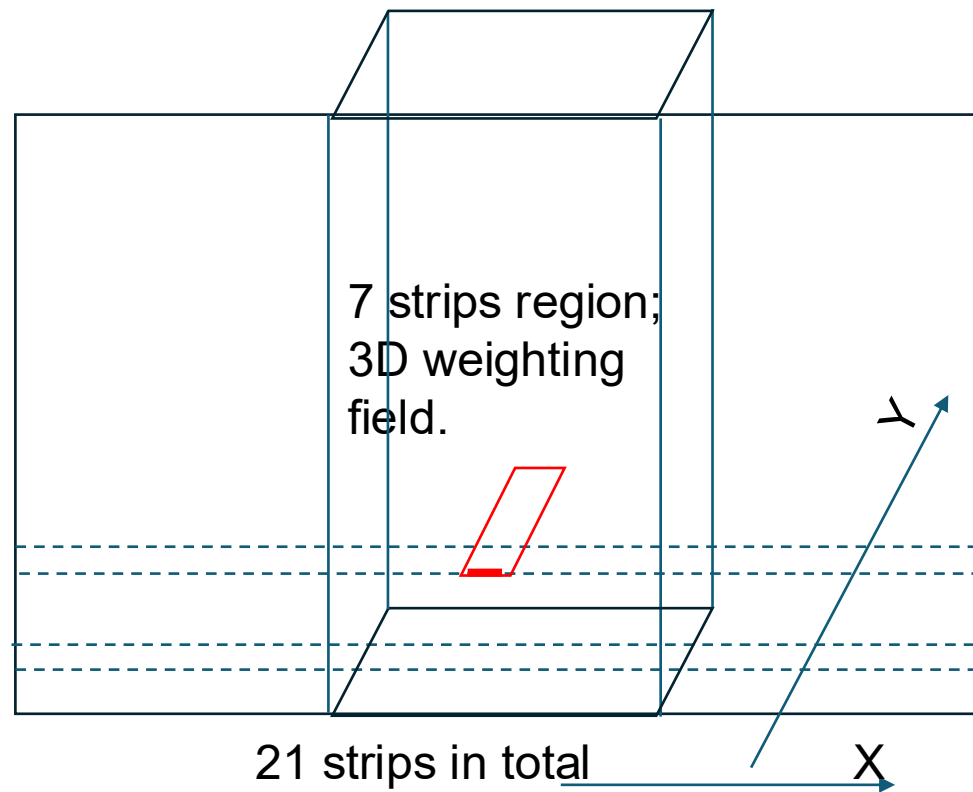

3D weighting field

initial value on boundary is got from
2D weighting field solution.

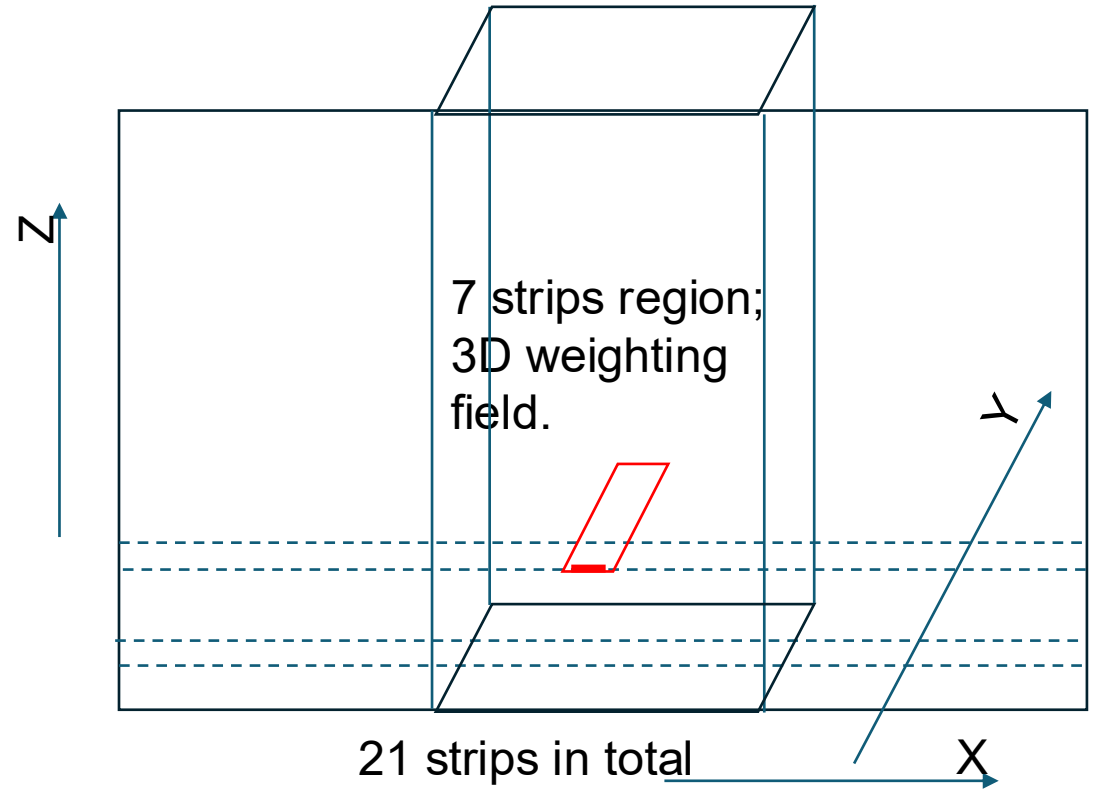

boundary

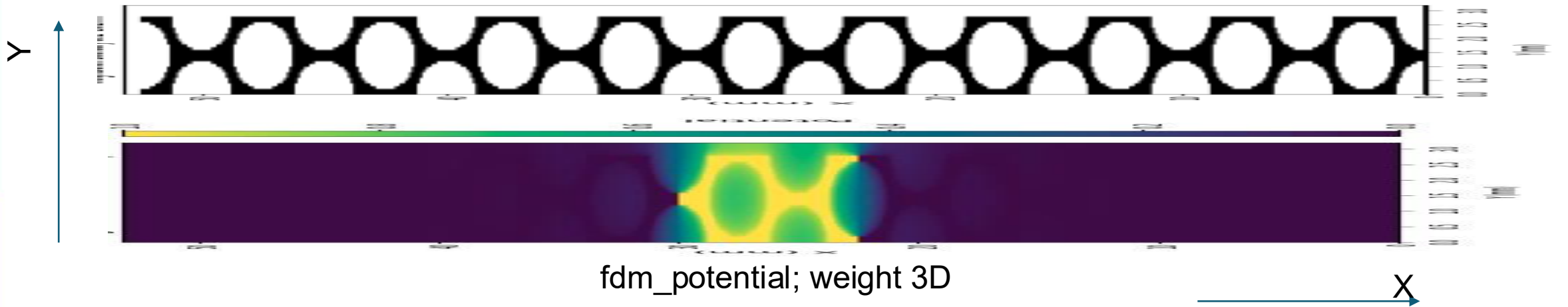

Velocity, starting points and drift paths

velocity distribution

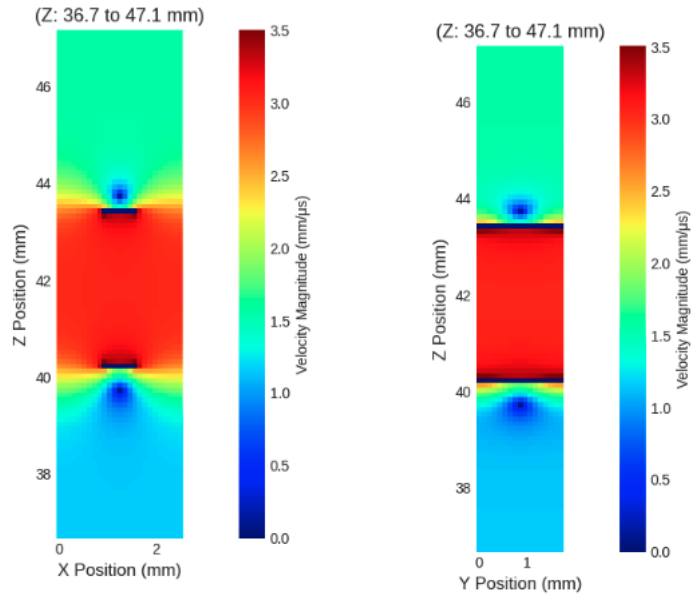

Drift Velocity Magnitude:
|v| range: [0.0000, 3.5935] mm/μs
|v| mean: 1.4554 mm/μs

electron drift paths

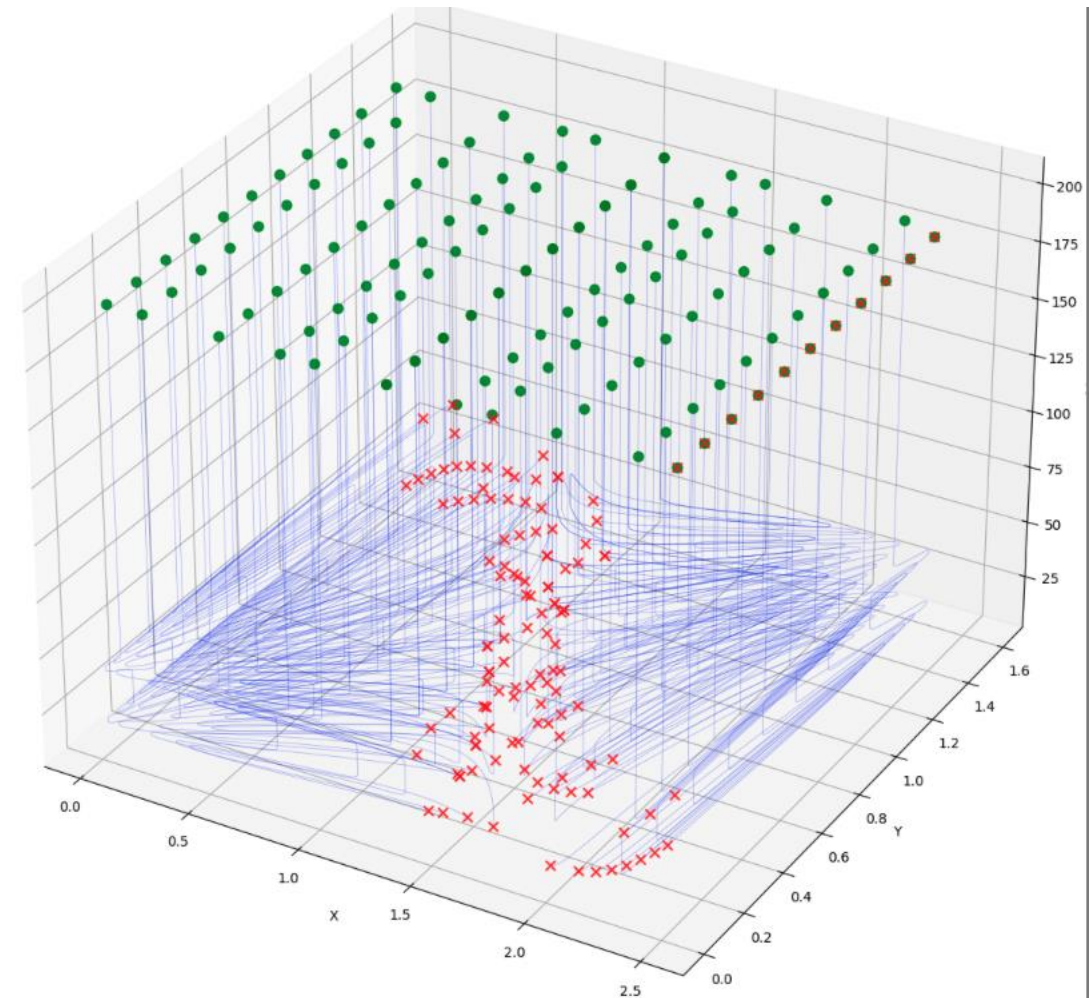

Induced current on u

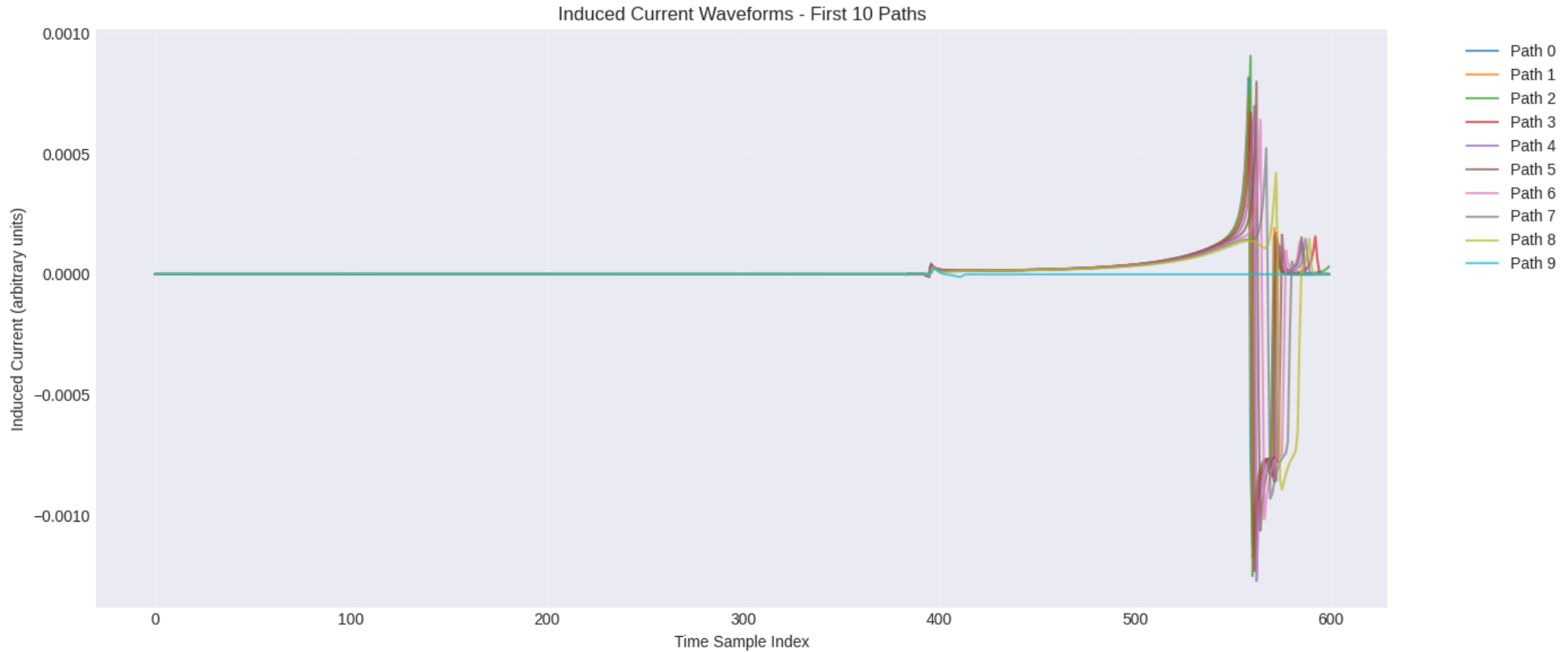

Induced current calculated using Ramo's theorem $i = -e \times \vec{v} \times \vec{E}_w$

induced current on v

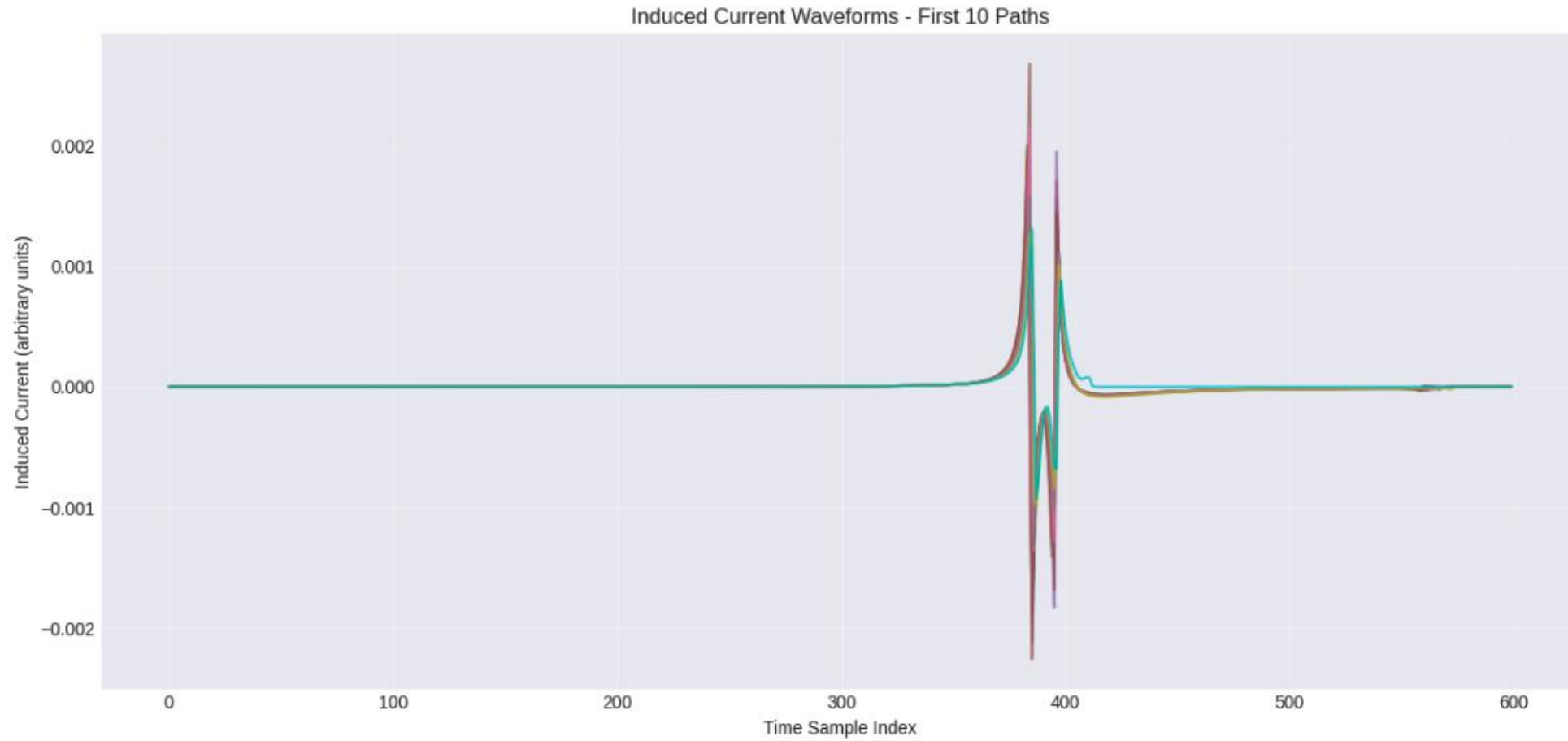

This is weird...I am still checking