

# Development of a Light Monitoring System for the SiPM Readout of the Barrel Imaging Calorimeter

Jun Seop SHIN, Bo Gyeong SEO, Jun Hyung PARK, Shin Hyung KIM

Department of Physics, Kyungpook National University



# Overview of BIC

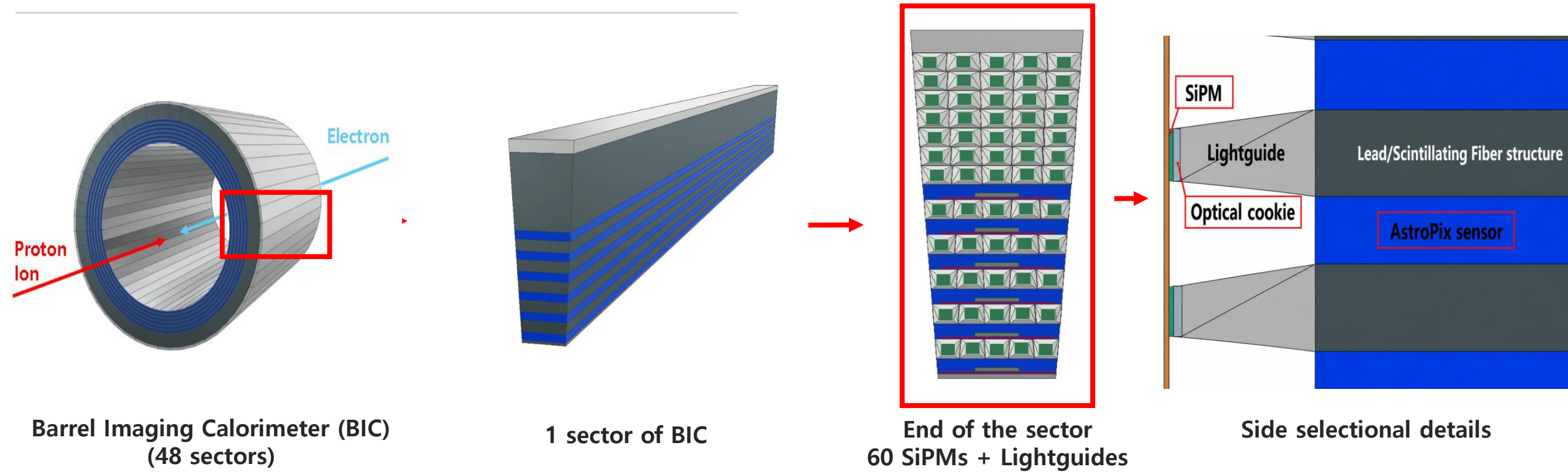

- Calorimeter readout Requirements
  - BIC energy resolution
  - Gain calibration mechanism
  - Light Monitoring System (LMS) structure

# SiPM Gain Calibration

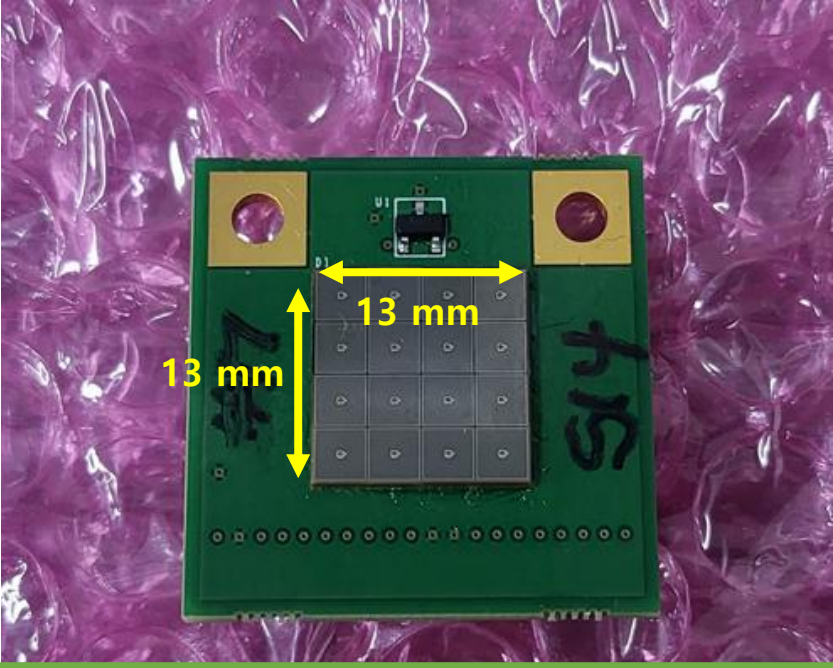

**Hamamatsu SiPM  
S14161-3050HS-04**

- Photo Detection Efficiency : 50% (450 nm)
- operating voltage 38.5 V
- Gain :  $2.5 \times 10^6$  at overvoltage 2.5 V
- 16 channel per 1 SiPM array
- 3531 pixels per 1 channel

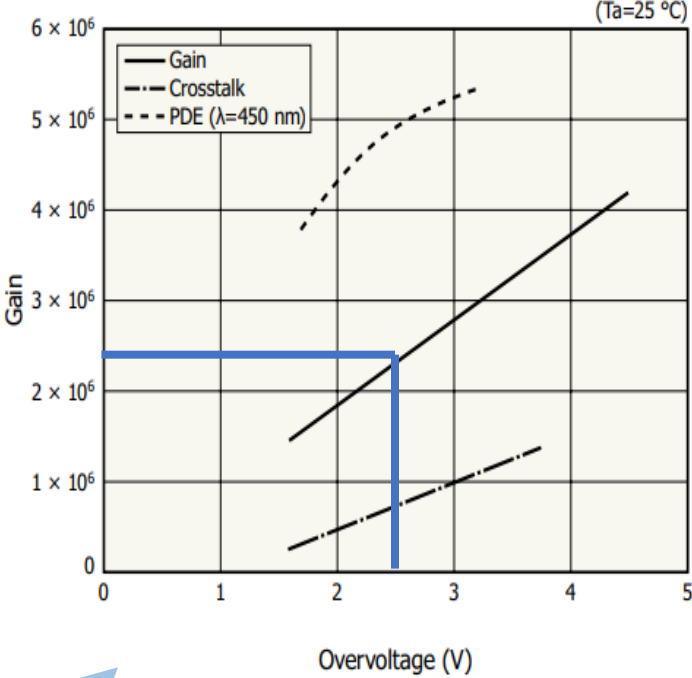

SiPM gain curve  
(Overvoltage – Gain)

- Each channel has different  $V_{br}$
- SiPM bias voltage  $\propto$  SiPM gain
- Gain calibration of each channel is critical
- To draw gain curve...  
 → LED setup !!

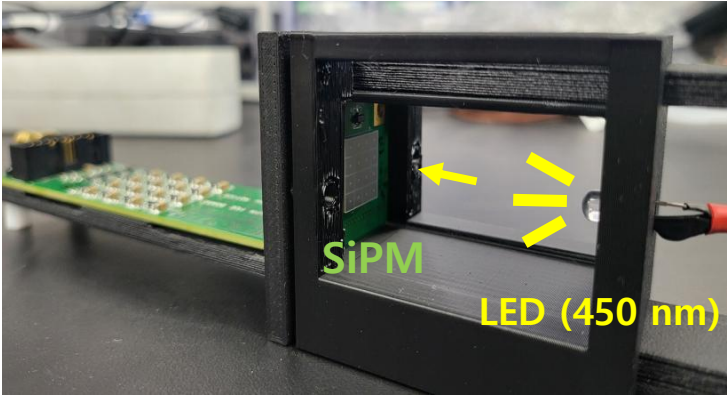

**LED test setup**

# SiPM Gain Calibration – LED Setup

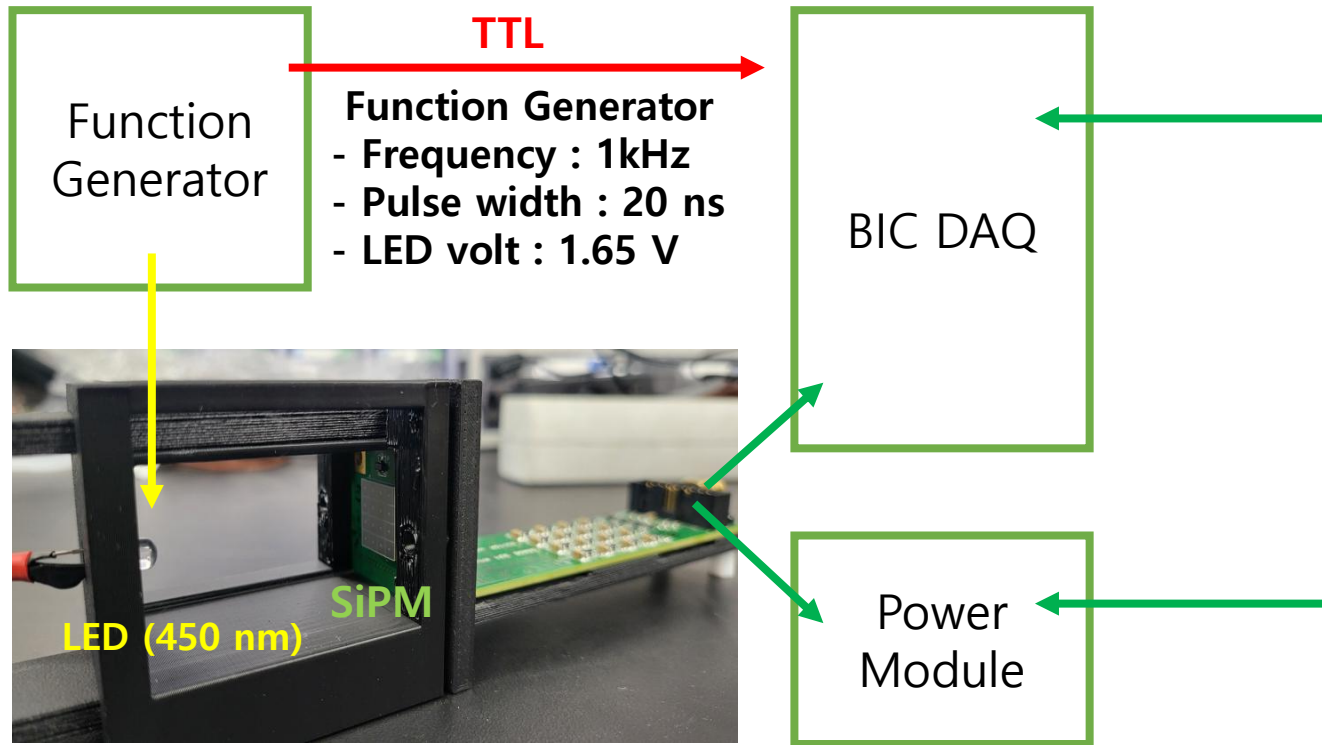

- Single photoelectron (SPE) measurement with LED setup
- Each channel was operated individually
- SPE scan was performed at different SiPM bias voltage for each channel.



- BIC DAQ
  - 62.5 MHz (16 ns) FADC
  - 14 bit ADC with voltage range 0~2 V



- BIC Power module
  - Give individual voltage for each SiPM channels
  - 12 bit DAC with voltage range 0~10 V
  - Get temperature data with SiPM temperature sensor

# SiPM Gain Calibration – LED Logic

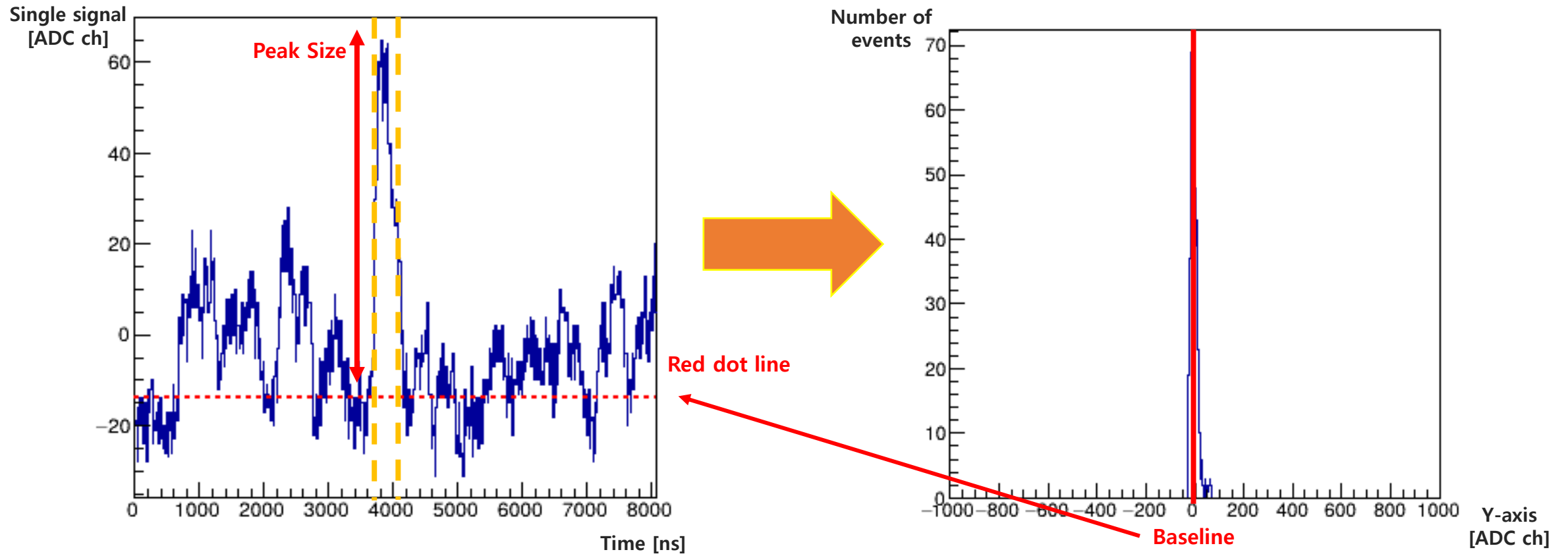

- Single event of SiPM each channel per each bias voltage
- To measure single photoelectron (SPE), Low intensity of LED was needed

- Baseline determined from y-axis projection of ADC values outside of the LED windows (High dark current rates)
- Red dot line (Peak position used as baseline)

# SiPM Gain Calibration – Peak ADC Distribution

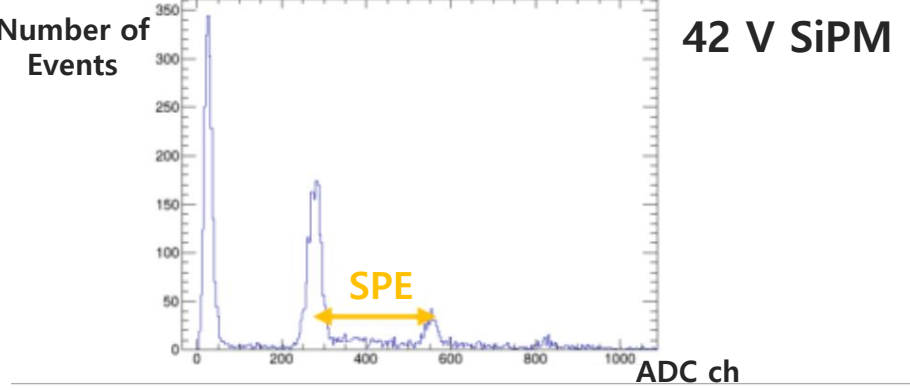
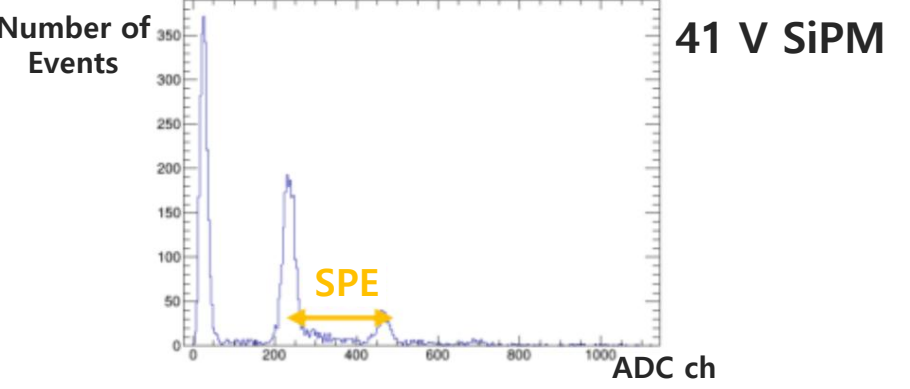
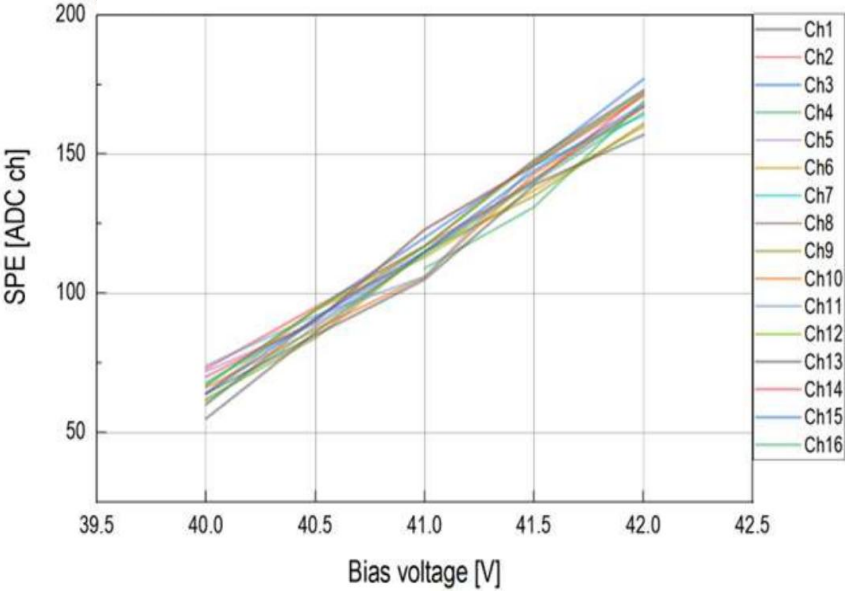
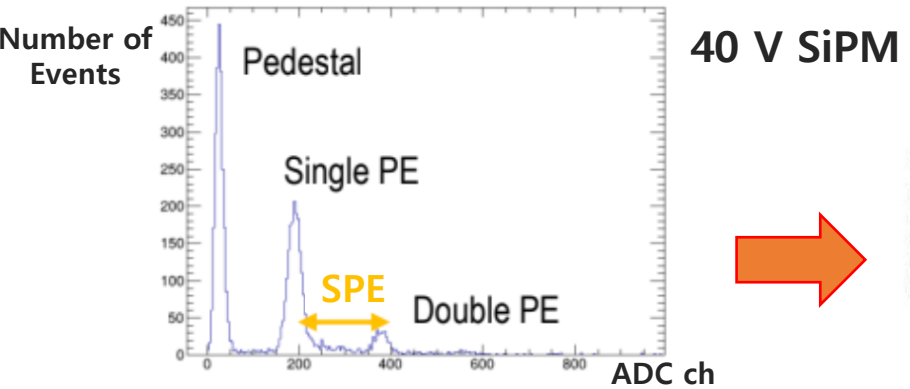

BIC HV 192.168.0.4

Load HV File Save Changes Run set\_BIC\_HV\_s14.exe .loaded: s14\_25CERN\_0.7ADC.tx

Common	Ch1	Ch2	Ch3	Ch4	Ch5	Ch6	Ch7	Ch8	Ch9	Ch10	Ch11	Ch12	Ch13	Ch14	Ch15	Ch16
Slot1	5.928	6.104	5.975	5.995	5.965	5.946	5.910	5.963	5.875	5.895	5.934	5.865	5.875	5.875	5.734	5.865
Slot2	5.940	5.963	5.857	5.965	5.887	5.763	5.975	5.928	5.804	5.752	5.840	5.840	5.810	5.765	5.722	5.795
Slot3	0.0	0.0	0.0	0.0	0.0	0.0	0.0	0.0	0.0	0.0	0.0	0.0	0.0	0.0	0.0	0.0
Slot4	0.0	0.0	0.0	0.0	0.0	0.0	0.0	0.0	0.0	0.0	0.0	0.0	0.0	0.0	0.0	0.0
Slot5	0.0	0.0	0.0	0.0	0.0	0.0	0.0	0.0	0.0	0.0	0.0	0.0	0.0	0.0	0.0	0.0
Slot6	0.0	0.0	0.0	0.0	0.0	0.0	0.0	0.0	0.0	0.0	0.0	0.0	0.0	0.0	0.0	0.0

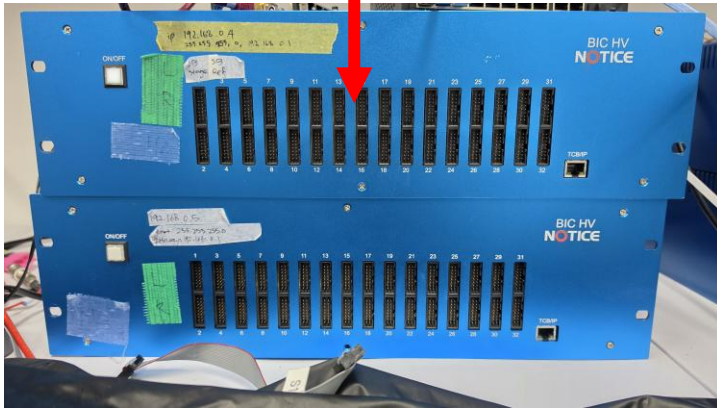

- SiPM Peak ADC Distribution with using LED Logic (Peak Size)
- Gain calibration already done

# Light Monitoring System (LMS) - Overview

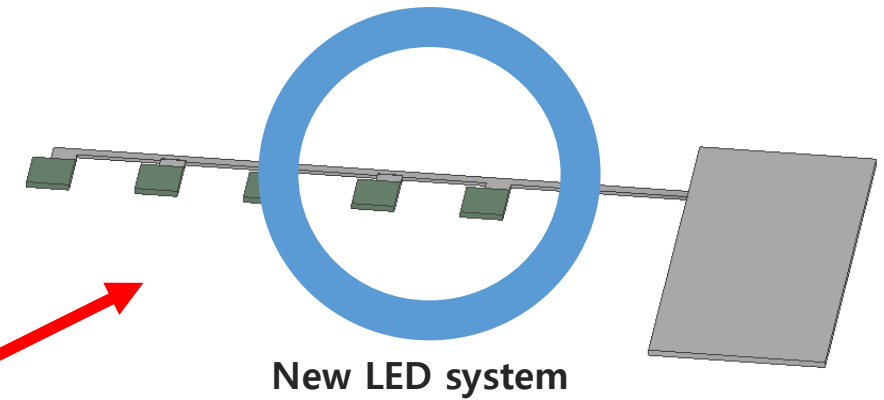
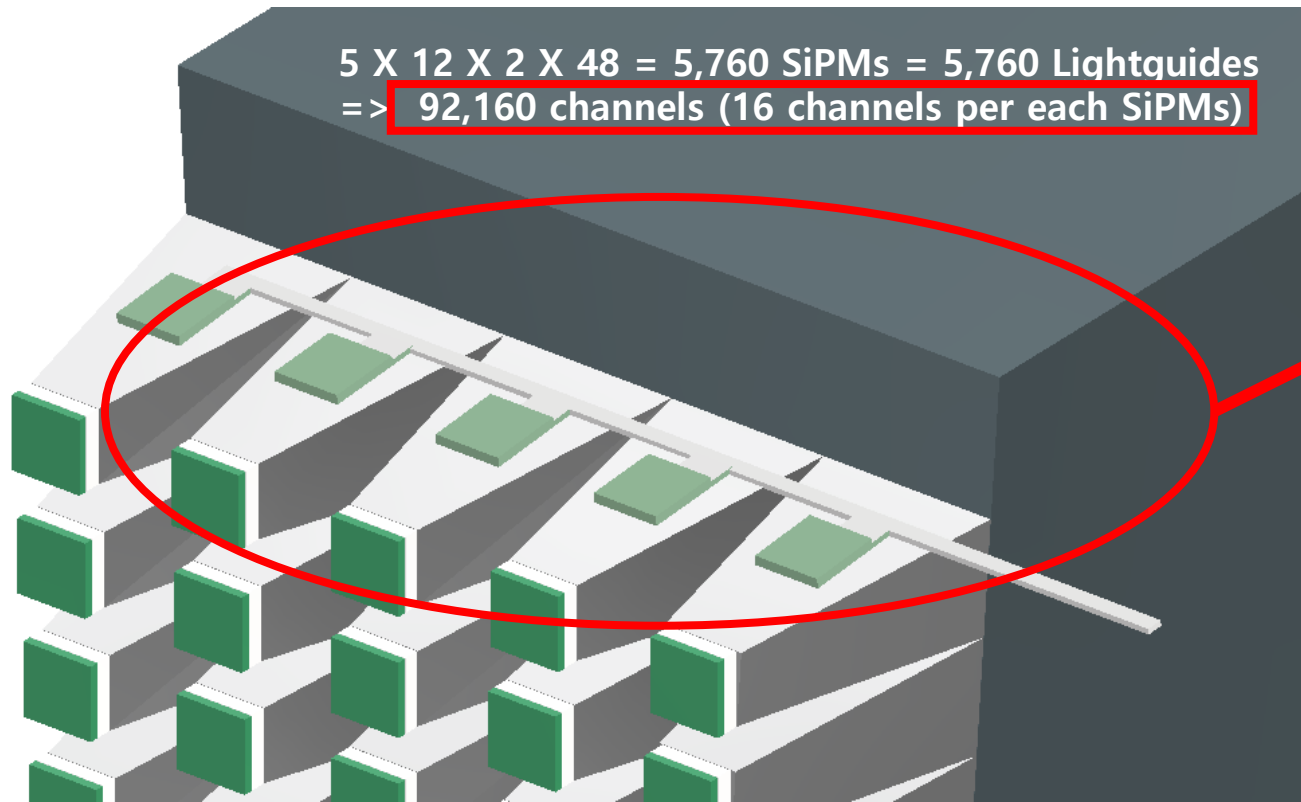

Previous LED setup

- Gain calibration should be needed while BIC running → LED setup must be installed together with the BIC
- Previous SiPM LED Setup cannot be fit in the BIC (No space)
- Too many SiPM & Lightguide → compact LED setup are required
- SiPM temperature dependence → monitoring system !!
- New LED system → attached with lightguide → Light monitoring system (LMS)

# Light Monitoring System (LMS)

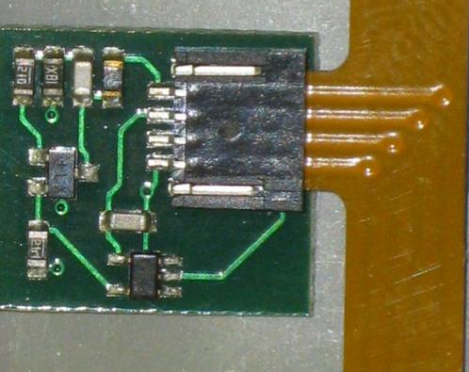

GlueX LED board circuit



GlueX controller board circuit

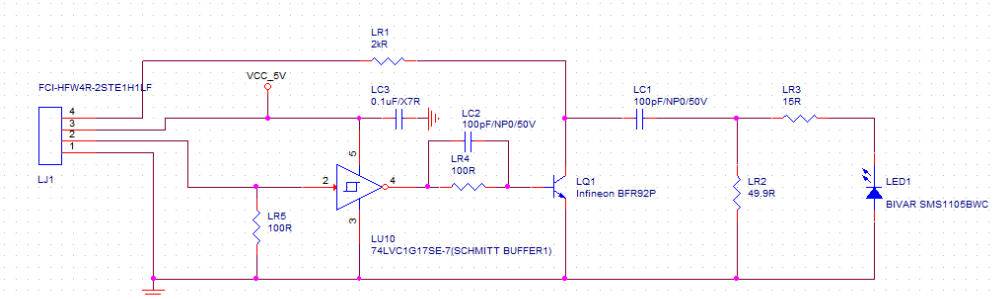
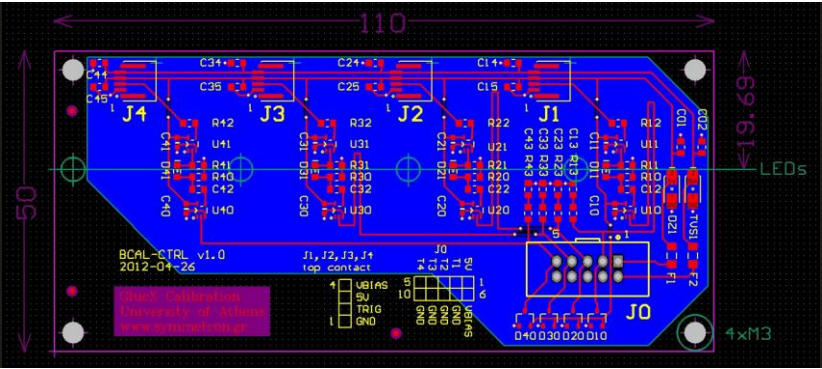

BIC LED board circuit

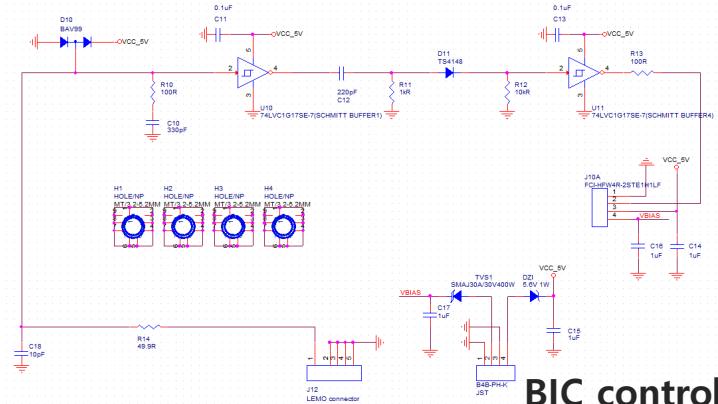

BIC controller board circuit

BIC LED & Controller board circuit (By Dr. Efstratios Anassontzis)

- GlueX LMS System (by Dr. Efstratios Anassontzis & Prof. Zisis Papandreou)
- Use LED pulse method from GlueX LED circuit → Make BIC LED circuit
- Controller board for LED trigger signal

# LMS – KNU LMS Board Design

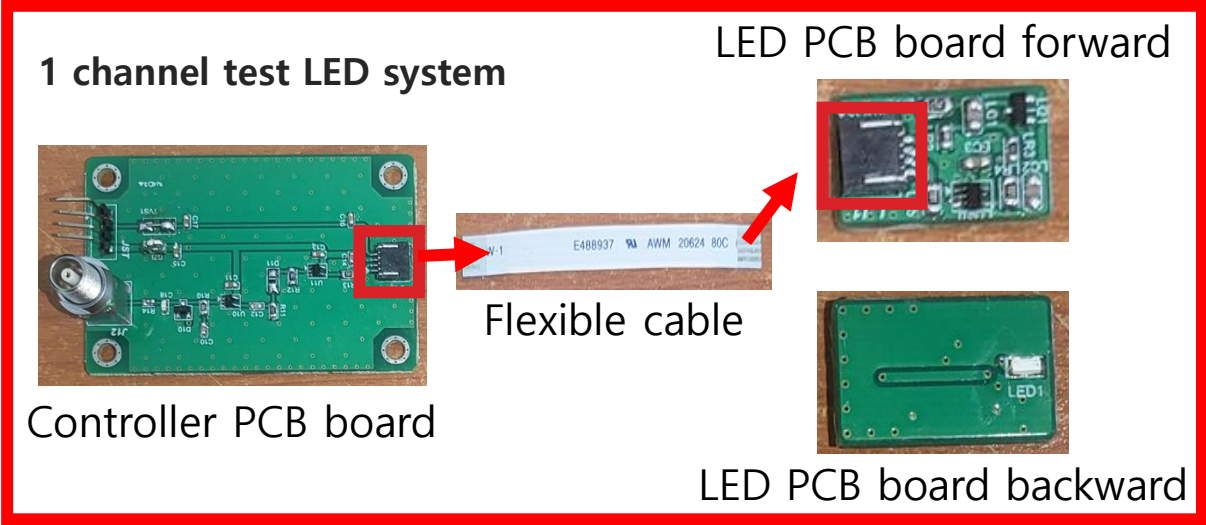
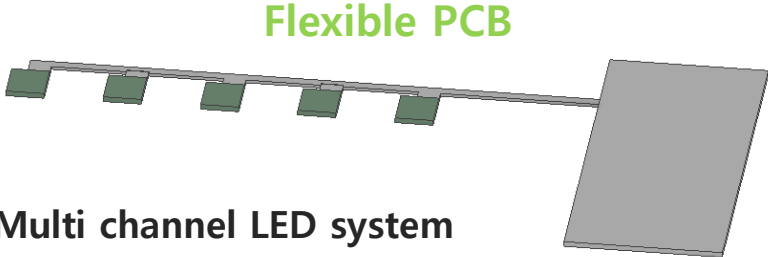
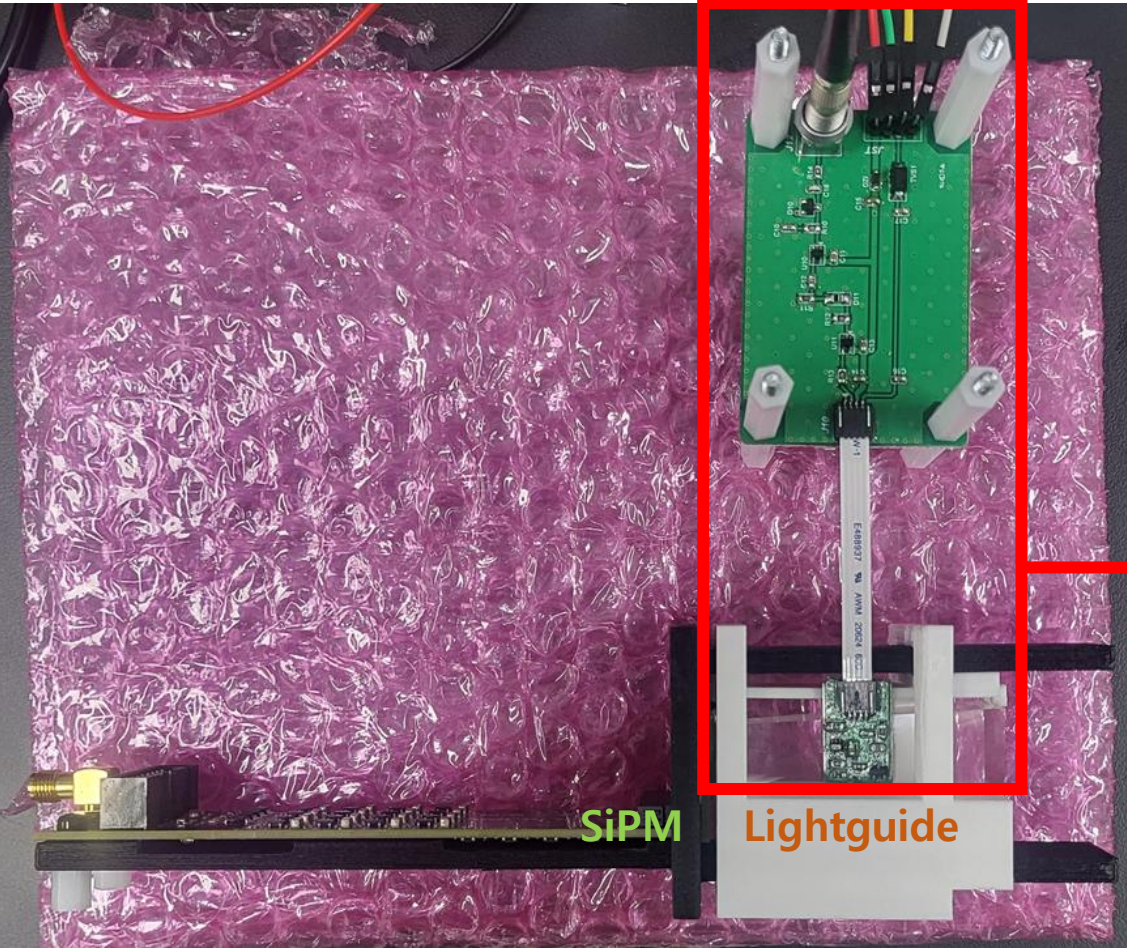

- LED board attached with lightguide (20 mm X 18 mm)
- Many channel LED board
- Full LED board operation using a flexible PCB
- 1 channel LED board for LED test

# LMS – Simulation for KNU Board

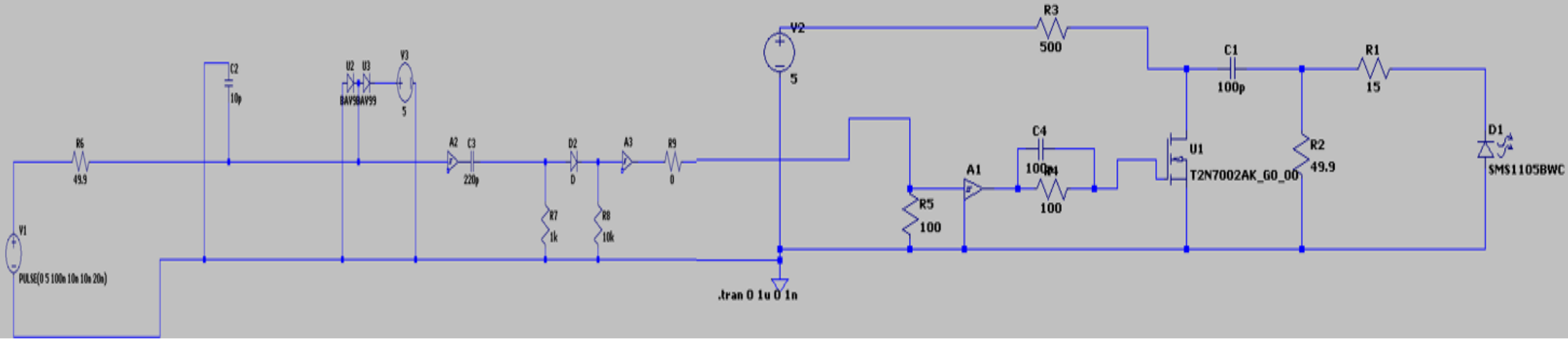

- Simulation with LTSpice
- Combine Controller board & LED board

# LMS – Simulation for KNU Board

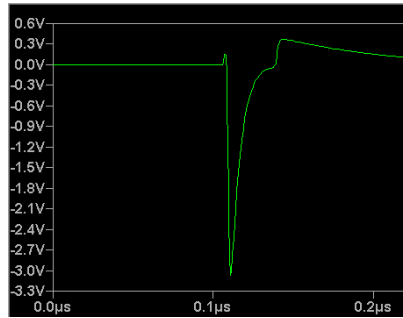
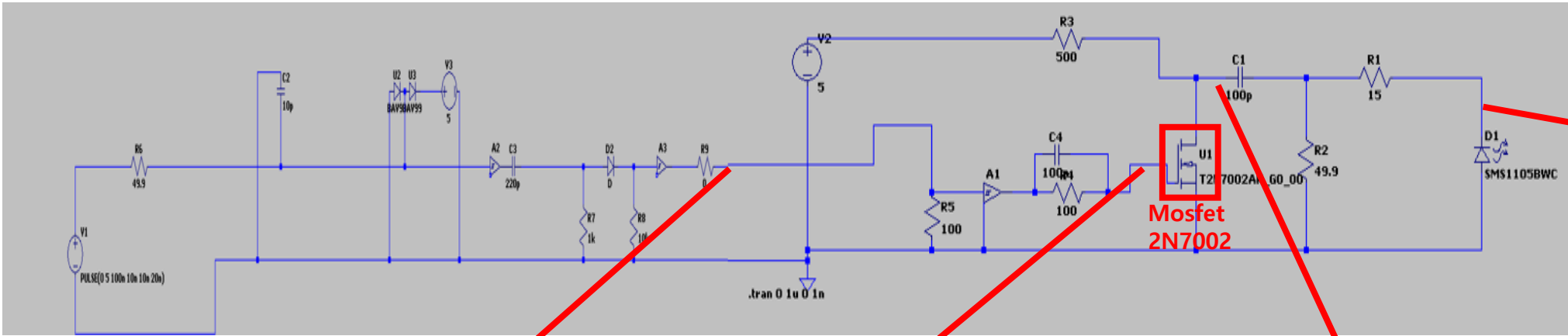

Voltage signal applied to the LED

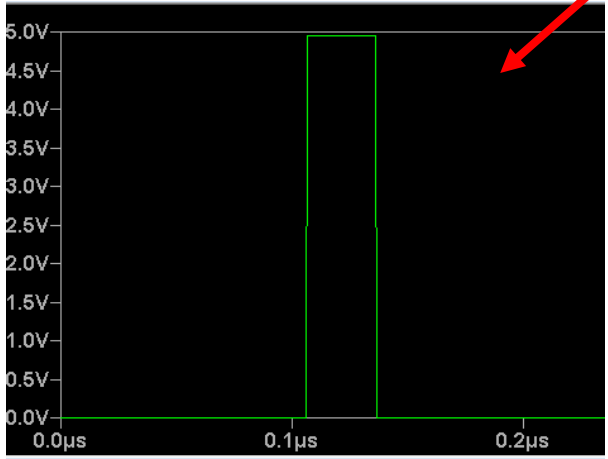

Trigger signal for the applied voltage at the end of controller board

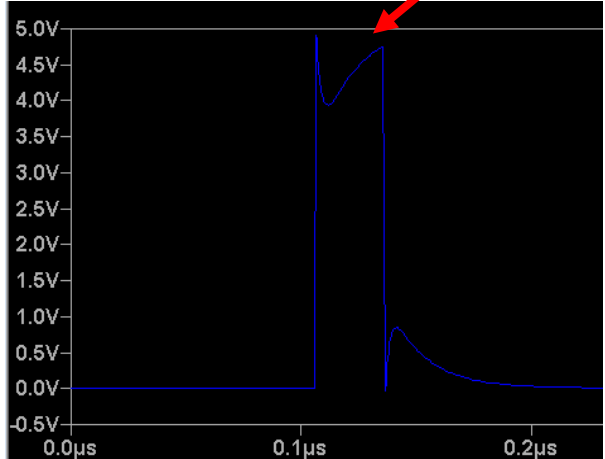

Trigger signal for the applied voltage before the mosfet

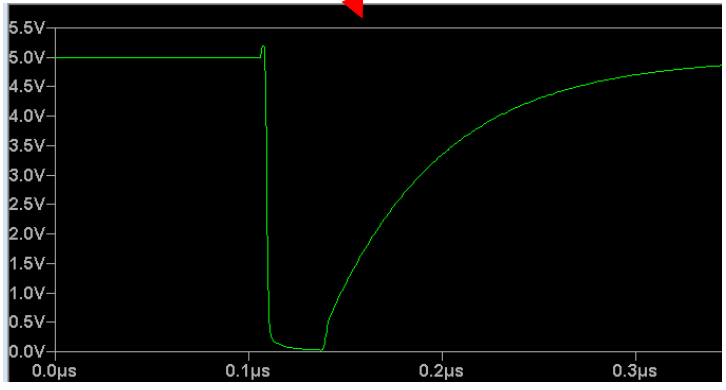

Recharging after the voltage charged (Discharged by the mosfet)

# LMS – Oscilloscope signal

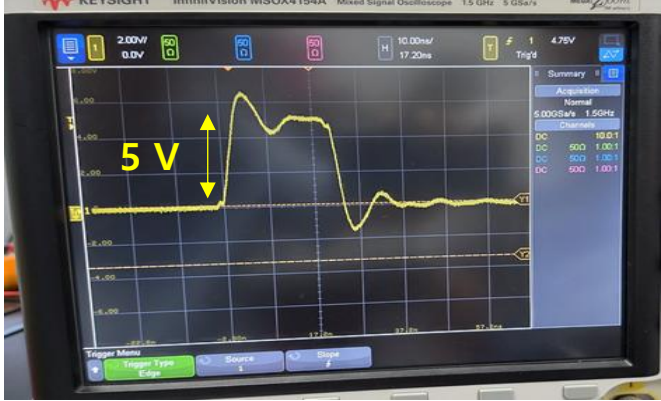
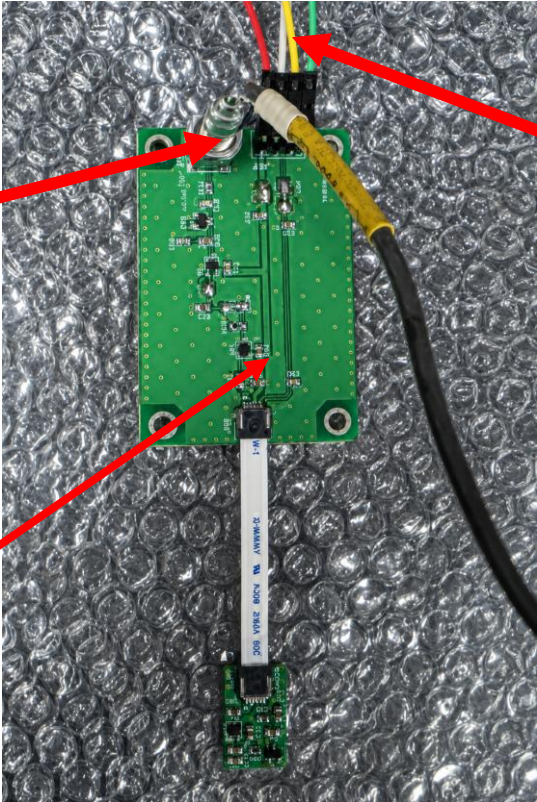

Trigger signal before the mosfet

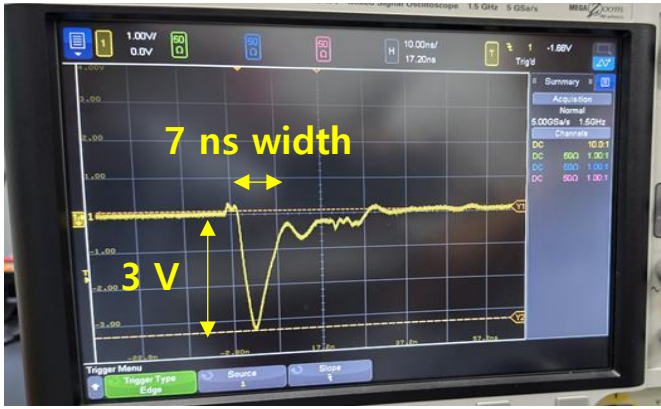
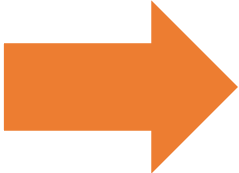
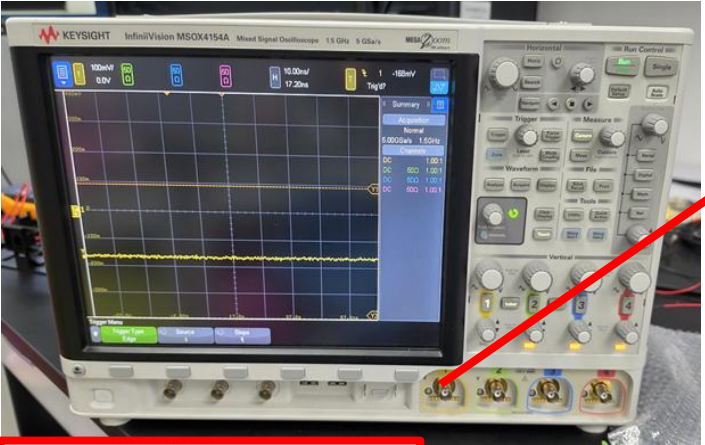

Voltage signal applied to the LED



Signal with passive probe

- Signals are similar between simulation & oscilloscope

# Summary

- Gain calibration : Necessary to get NPE
- DAQ trigger logic : To get accurate Peak Size
- For BIC, Compact LMS is necessary
- 1 channel LED & Controller test board
- Signal similarity on oscilloscope and simulation

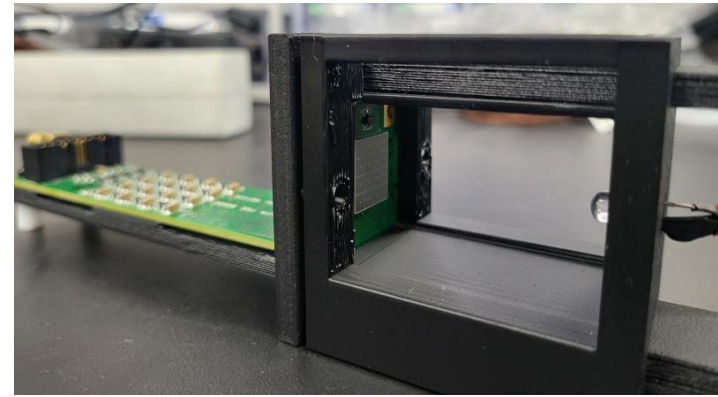

LED test setup for 1 SiPM board

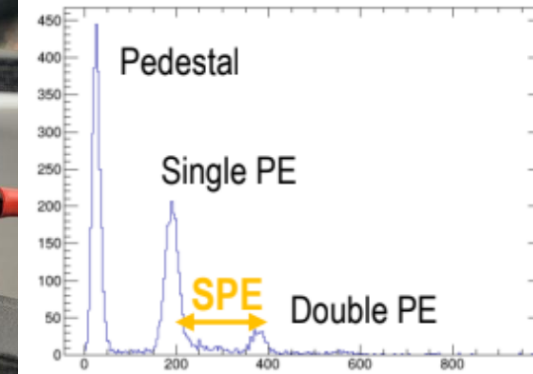

Peak ADC

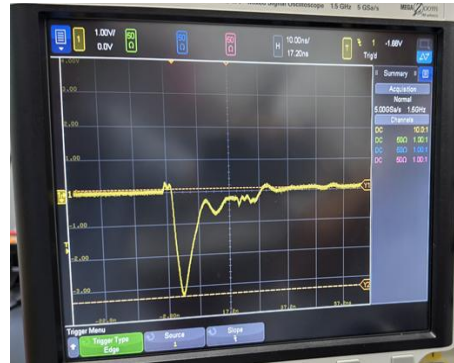
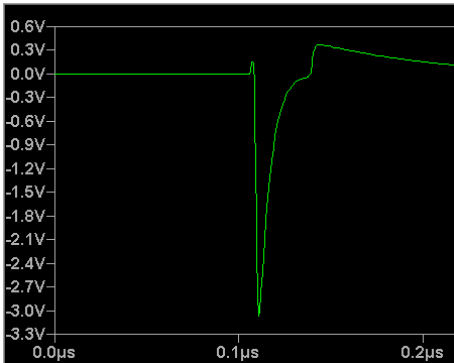

Voltage signal applied to the LED  
(Left : simulation, Right : oscilloscope)



LMS system

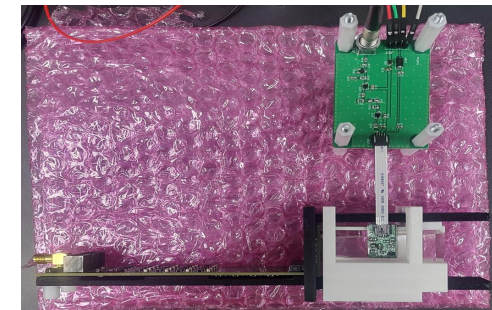

LED test board

# Backup

---

# LED circuit

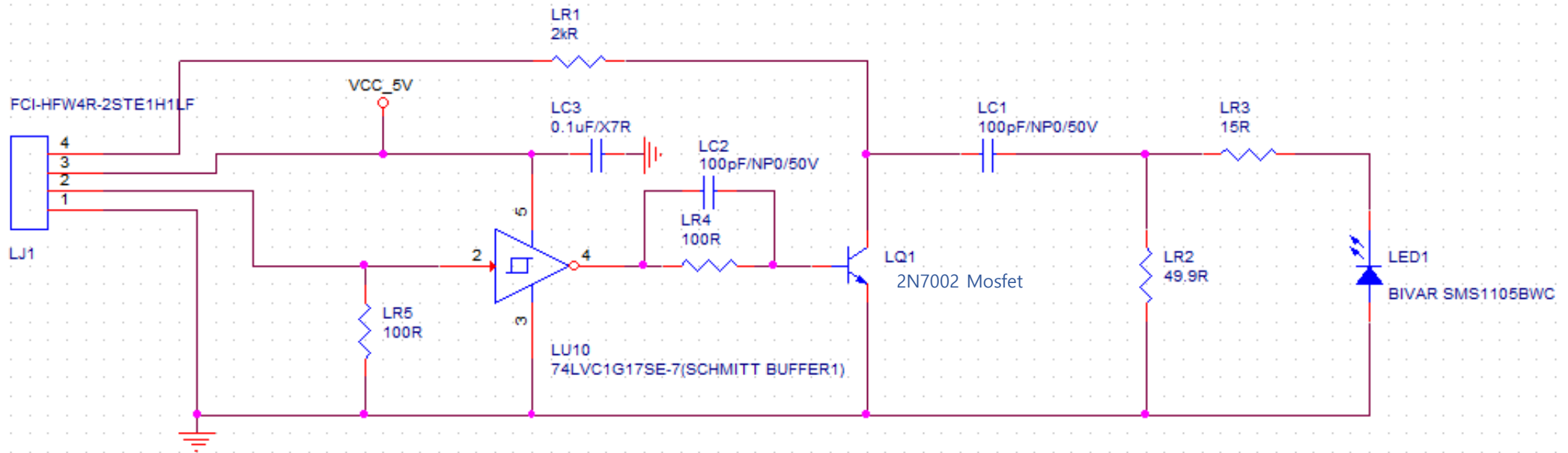

- KNU LED board circuit
- Schmitt Buffer for accurate trigger signal transmission
- Mosfet fot switch → Discharge the capacitor (LC1) → 7 ns, 3 V voltage pulse is applied to LED

# LED circuit

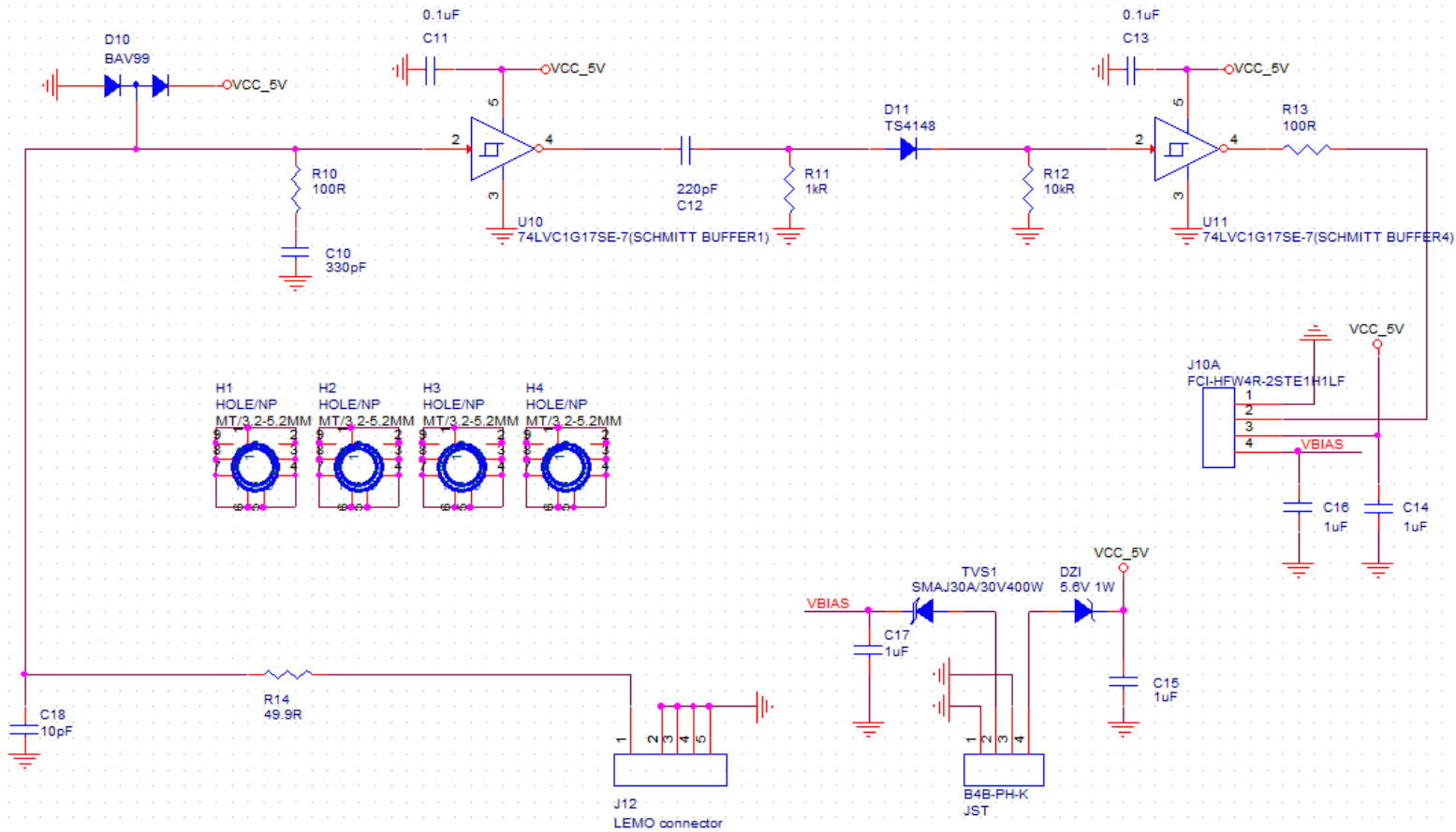

- KNU Controller board circuit
- 1 channel for test circuit (Ultimately 7 channel for BIC bulk)

# LED circuit

Nuclear Instruments and Methods in Physics Research A 738 (2014) 41–49



Contents lists available at ScienceDirect

Nuclear Instruments and Methods in Physics Research A

journal homepage: [www.elsevier.com/locate/nima](http://www.elsevier.com/locate/nima)



## Relative gain monitoring of the GlueX calorimeters<sup>☆</sup>

E.G. Anassontzis<sup>a</sup>, P. Ioannou<sup>a</sup>, C. Kourkoumelis<sup>a,\*</sup>, G. Vasileiadis<sup>a</sup>, G. Voulgaris<sup>a</sup>, E. Kappos<sup>b</sup>, I. Beattie<sup>c</sup>, S. Krueger<sup>c</sup>, G.J. Lolos<sup>c</sup>, Z. Papandreou<sup>c,\*\*</sup>, A.Yu. Semenov<sup>c</sup>, J. Frye<sup>d</sup>, J. Leckey<sup>d</sup>, M.R. Shepherd<sup>d</sup>, T. Bogart<sup>e,1</sup>, D. Lawrence<sup>e</sup>, E.S. Smith<sup>e</sup>

<sup>a</sup> National and Kapodestrian University of Athens, 15771 Athens, Greece  
<sup>b</sup> Symmetron Electronic Applications, 1 Antikythron Street, 153 44 Gerakas, Greece  
<sup>c</sup> Department of Physics, University of Regina, Regina, Saskatchewan, Canada S4S 0A2  
<sup>d</sup> Department of Physics, Indiana University, Bloomington, IN 47405-7000, USA  
<sup>e</sup> Thomas Jefferson National Accelerator Facility (Jefferson Laboratory), Newport News, VA 23606, USA

## The GlueX Collaboration

### ARTICLE INFO

Article history:  
 Received 22 September 2013  
 Received in revised form  
 13 November 2013  
 Accepted 13 November 2013  
 Available online 25 November 2013

Keywords:  
 Gain monitoring  
 LED  
 Multi photon pixel counter  
 Lead glass calorimeter  
 Sampling calorimeter

### ABSTRACT

The relative gain of the photodetectors for the GlueX Barrel and Forward calorimeters will be monitored using modular LED driver systems. The BCAL system consists of a global controller that feeds power, bias voltage and trigger signals to 96 local controllers situated at the ends of the 48 BCAL modules, which drive 40 LEDs associated with the 40 light guides at the end of each module. The FCAL system consists also of a global controller, a local controller for each acrylic quadrant covering the face of the FCAL, and ten 4-LED pulser boards per local controller connected in a star configuration along the edges of the acrylic panes. The respective systems are currently being installed on the detectors and their tested performance is presented herein.

© 2013 Elsevier B.V. All rights reserved.

### 1. Project background

as a sampling calorimeter and will be deployed inside GlueX's superconducting solenoid.

### 2.1. BCAL LED monitoring design

The monitoring system is designed to track the stability of the MPPC output signals about once per day between data runs and has the advantage that (together with selective HV settings) one can pulse individual MPPCs that are normally summed into an fADC input. Moreover, the observation of each LED by opposite MPPCs on the same readout cell provides a means of separating out temperature drifts as gradients on the upstream end from those on the downstream end in conjunction with the MPPC cooling plate temperature recordings.

To minimize cabling, simplify construction and reduce size and cost while maintaining a degree of flexibility in its pulsing options, a modular LED driver system has been designed in three levels. At the top level, a global controller feeds power, bias voltage and four trigger signals to 96 local controllers situated at the ends of the 48 BCAL modules, one controller per module per side. At the next level, each local controller (or BCAL controller) pulses the 40 LEDs associated with the 40 light guides at the end of a module as four independent trigger groups. Each group corresponds to one of the four columns of ten light guides shown in Fig. 1(d). LEDs in the same group are fired simultaneously by one of the four trigger signals, illuminating an entire column of light guides. At the third level, a miniature 1-LED pulser circuit board is attached directly onto each light guide, directing light towards the opposite end of the module. LED pulser boards in groups of ten are attached to a common bus cable connected to the controller board. The configuration of a BCAL controller with 40 LED pulser boards instrumenting one end of one module is shown in Fig. 2.

BCAL controllers buffer the four in-coming trigger signals and relay each one to one column of ten LEDs using a bespoke flat flexible cable to carry the common trigger along with the bias and supply voltages, as illustrated in the left panel of Fig. 3. Finally, each pulser board regenerates the in-coming trigger using a fast, high-current buffer to obtain a clean, fast-rising waveform which drives a high-speed MOSFET switch. This results in an  $\approx 7$  ns FWHM light pulse as a charged capacitor discharges through the LED. The actual circuit board is depicted in the right panel of Fig. 3.

The pulser circuit schematic is shown in Fig. 4. The energy

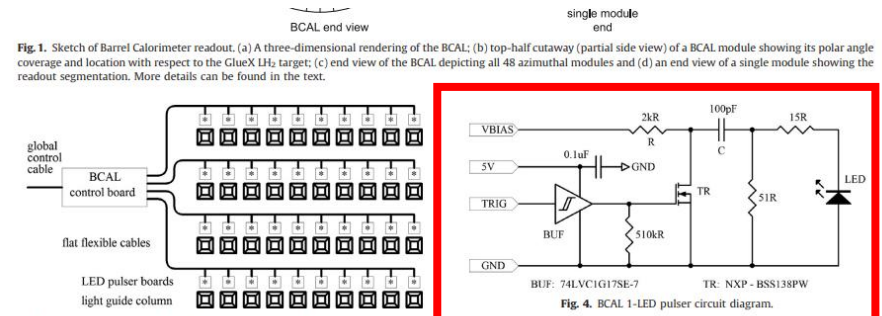

Fig. 2. Configuration of the BCAL LED monitoring system. The 335 mm bespoke flat flexible cable caters for the slightly varying pitch between light guides.



Fig. 3. Left panel: one end of a prototype BCAL module, showing two of its four columns of light guides. The LED pulsers are mounted on the side of the light guides attached to a common flexible cable. The free end of the flexible cable connects to the control board (not shown here). Right panel: BCAL LED pulser

LED monitoring system is independent of the MPPC bias distribution system, thus allowing independent monitoring of individual MPPCs through each readout sum. In summary, the BCAL system employs a total of 3840 ( $48 \times 2 \times 40$ ) LED pulser boards, 384 flat flexible cables, and 96 ( $48 \times 2$ ) controllers. Details of the BCAL monitoring system can be found elsewhere [10].

Major considerations in the design of the LED light pulser were (1) to minimize its physical size, due to the very limited space available between light guides as is evident from Fig. 3, (2) very low power dissipation, to minimize temperature variations that deteriorate the performance stability of the LEDs, (3) to achieve nanosecond performance with a wide variety of LED types and wavelengths, (4) to control the emitted pulse intensity, and (5) to minimize any electromagnetic interference that might affect the performance of MPPCs. On those grounds, and mainly (1), pulser designs based on monostable multivibrators, pulse-shape transistors

- Origin of the KNU LMS Design  
 By Dr. Efstratios Anassontzis & Prof. Zisis Papandreou