



June 16, 2026, Argonne

H2GCROC/ CALOROC updates

PRESENTED BY

Norbert Novitzky

ORNL



U.S. DEPARTMENT
of ENERGY

ORNL IS MANAGED BY UT-BATTELLE LLC
FOR THE US DEPARTMENT OF ENERGY



ROC chips standard structure

❑ H2GCROC (for SiPM readout) is an HL-LHC colored ASICs (external L1 trigger)

❑ Below is an calorimetry structure (but interfaces for CALOROC will similar)

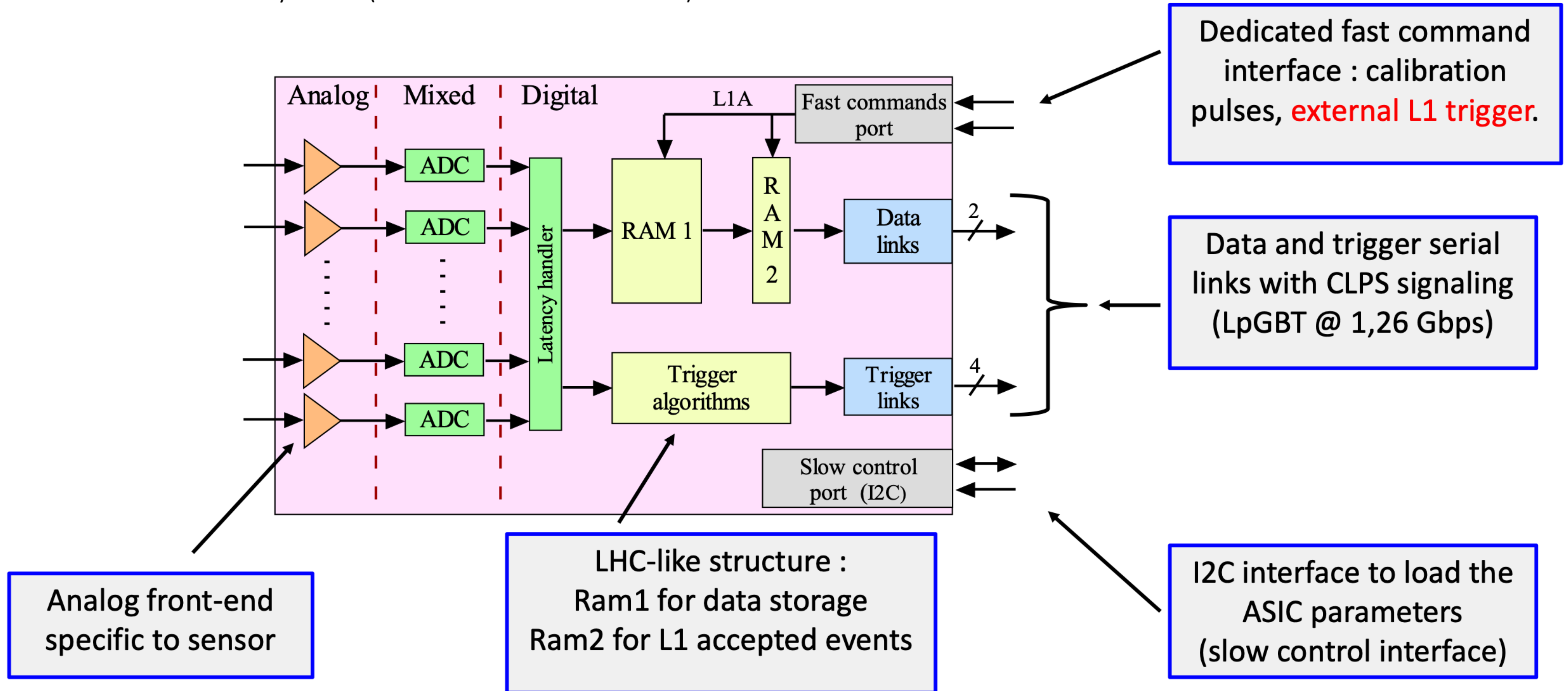

□ CALOROC main changes:

- Released in 2 versions: CALOROC-A and CALOROC-B
- New 6-layer substrate – BGA (common)
- New digital processing (common)
- New testboards (common)

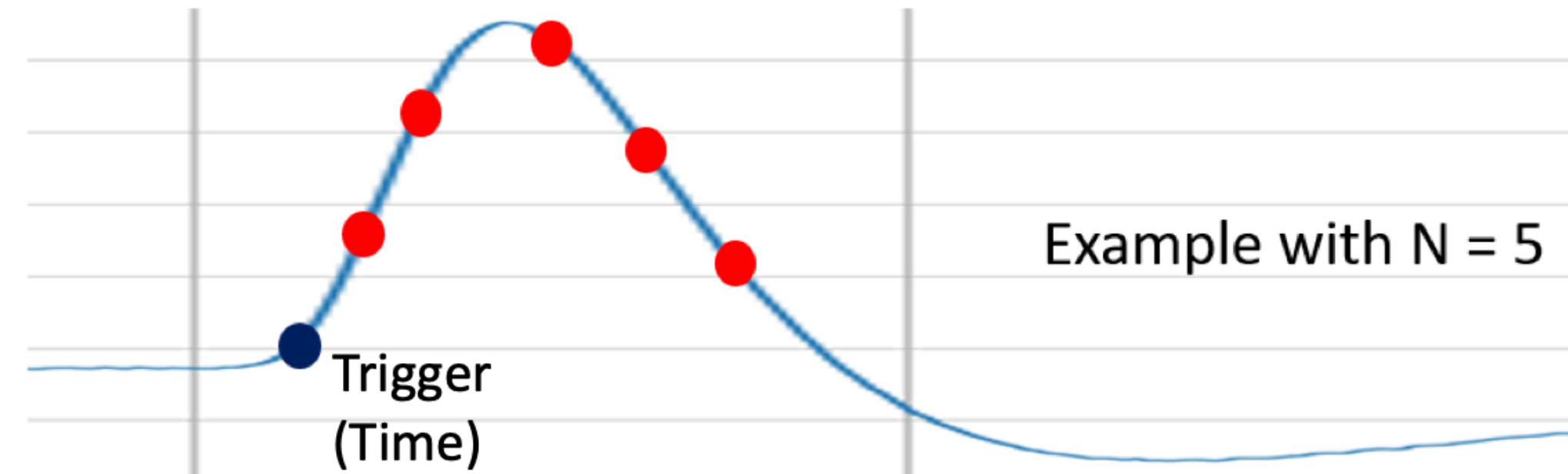

CALOROC 1A
CMS front-end
Low SiPM capacitance

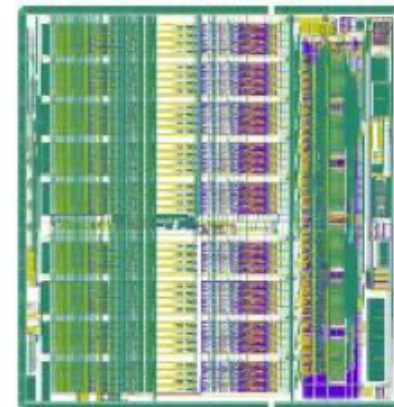

Measurements possible

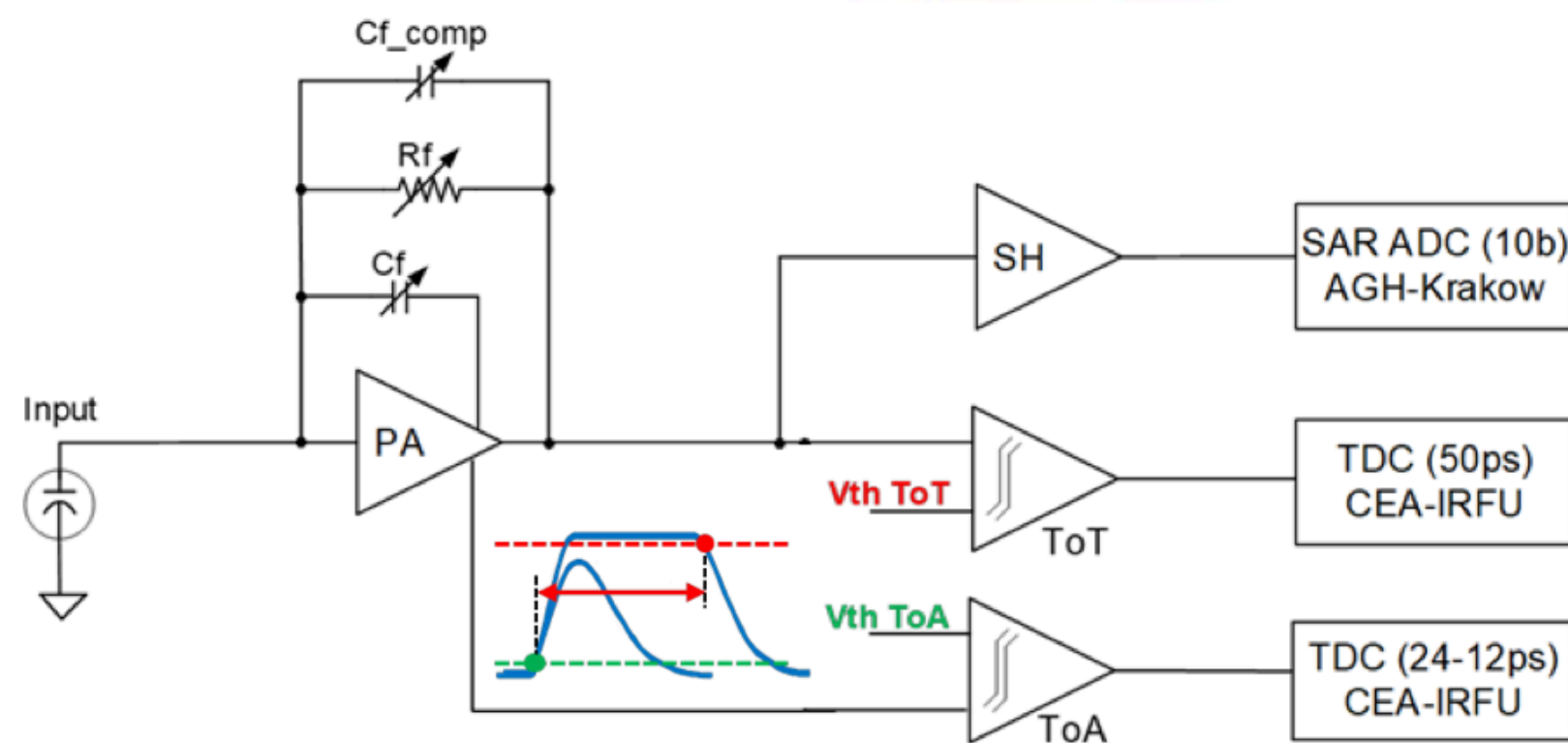

EIC 2026

CALOROC 1B
New switched-gain front-end
High SiPM capacitance



Measurements in progress

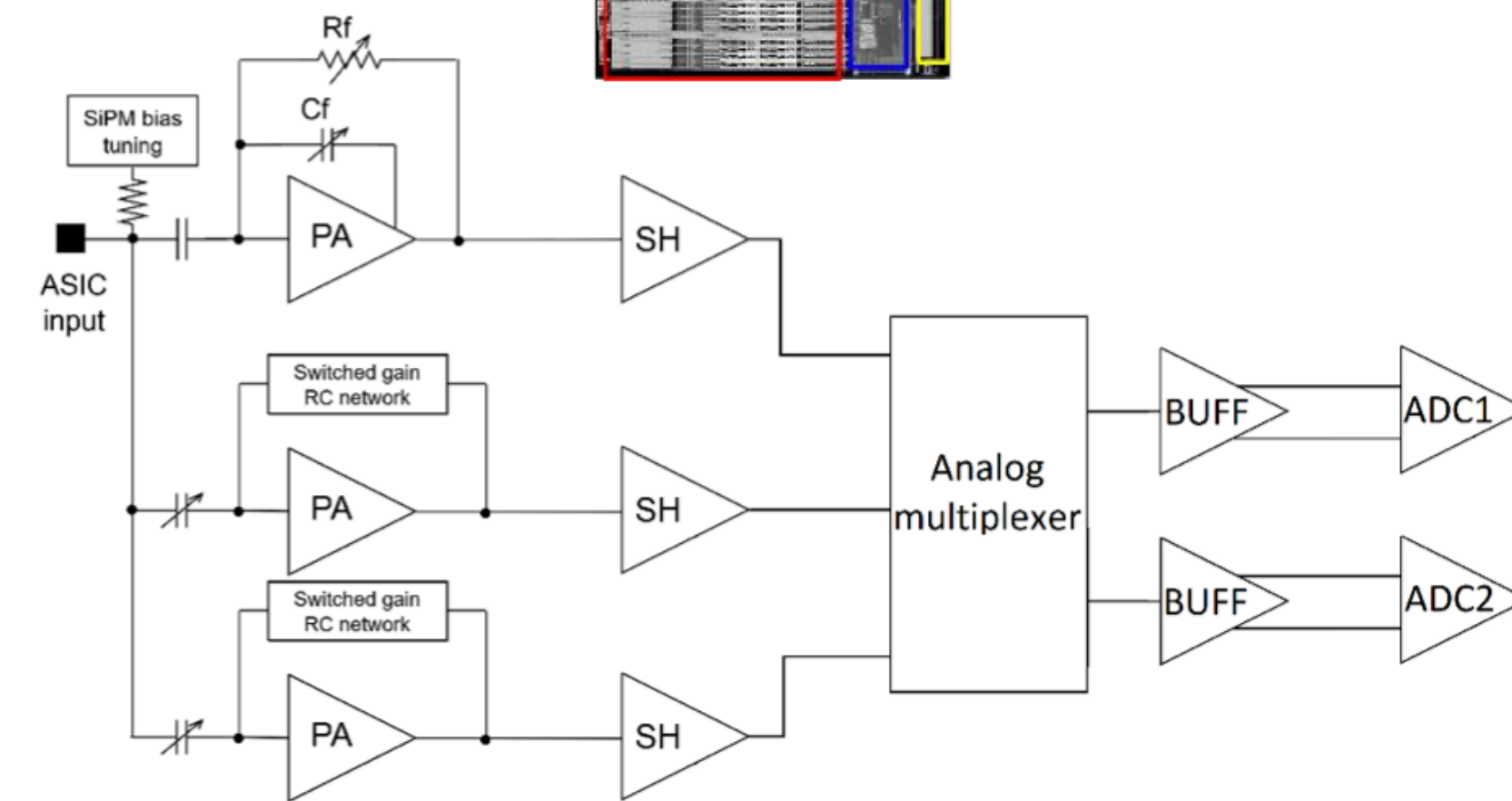

2

- ❑ Waveform for HG on the left + gain switching on the right:
 - ❑ Example with Cd of 8.96 nF

Waveform for high gain shaper @8.96nf configuration

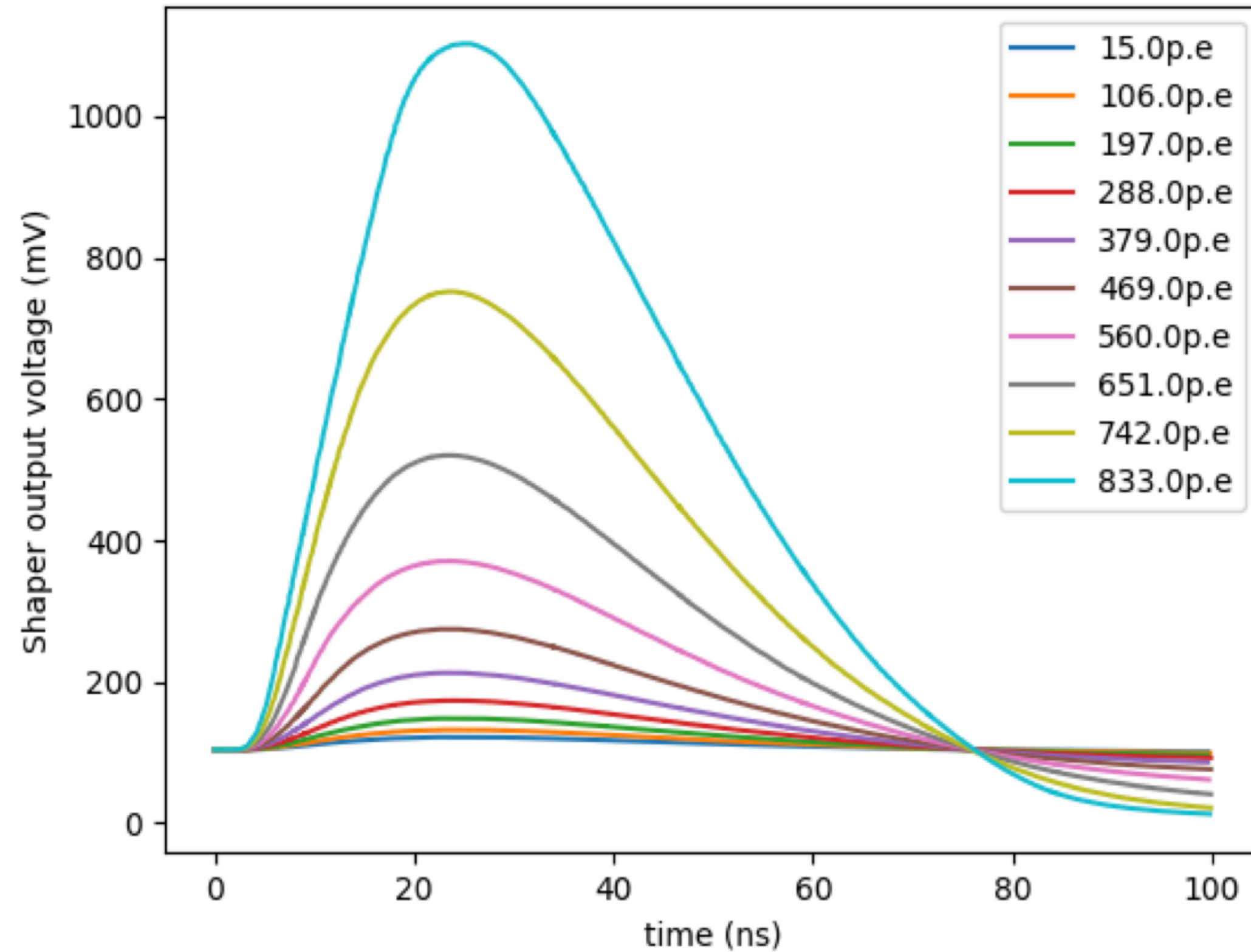

Waveform for medium gain shaper @8.96nf configuration

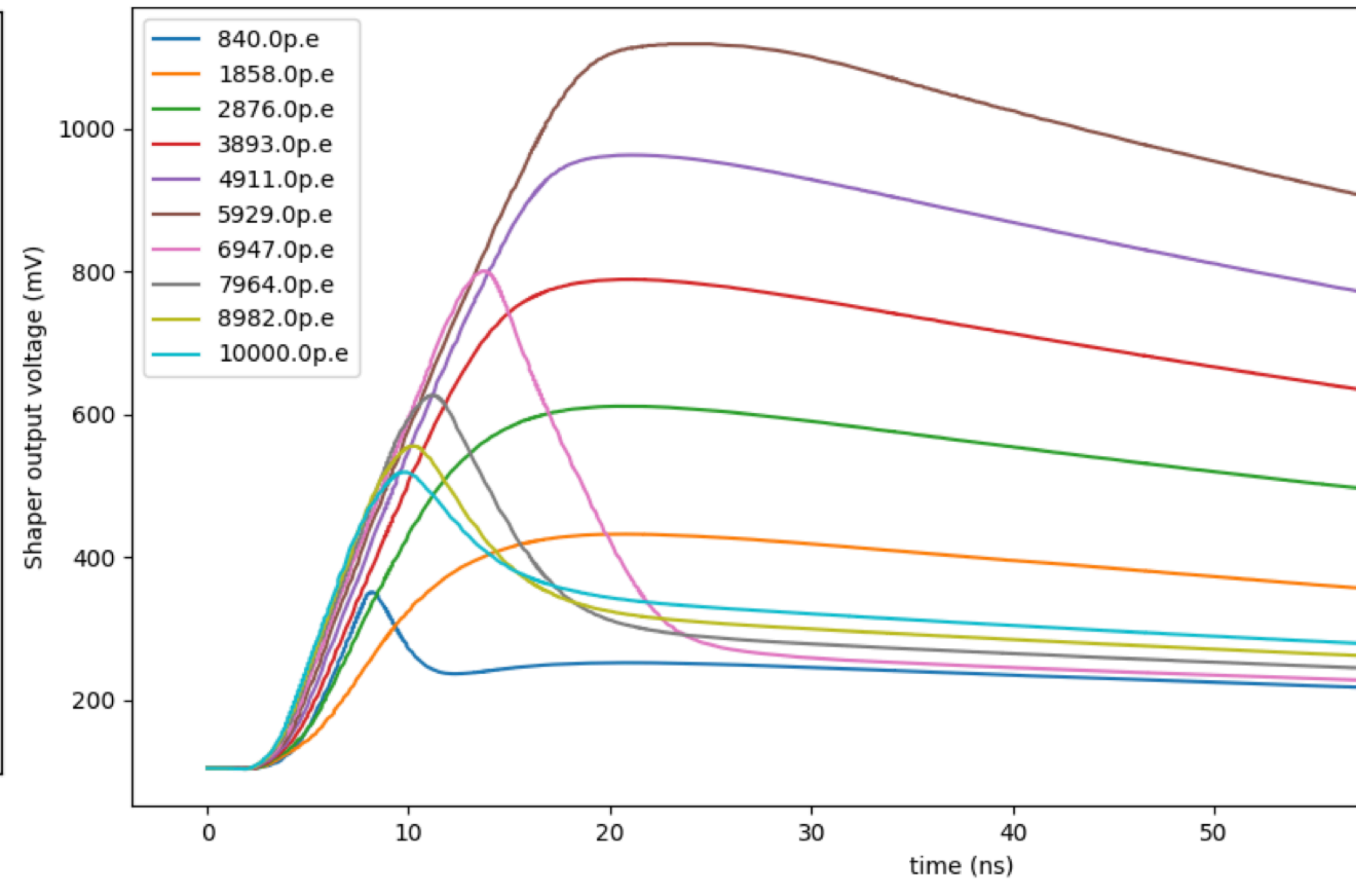

External charge injection setup:

- 2.2nF detector capacitance
- 330pF injection capacitance
- Rise time: 2ns with a 8.25ns low pass filter

Results:

- Dynamic range of up to 1.47nC
- Linearity error of less than 1% for all gains except the low gain
- Linearity error close to 1% for the low gain

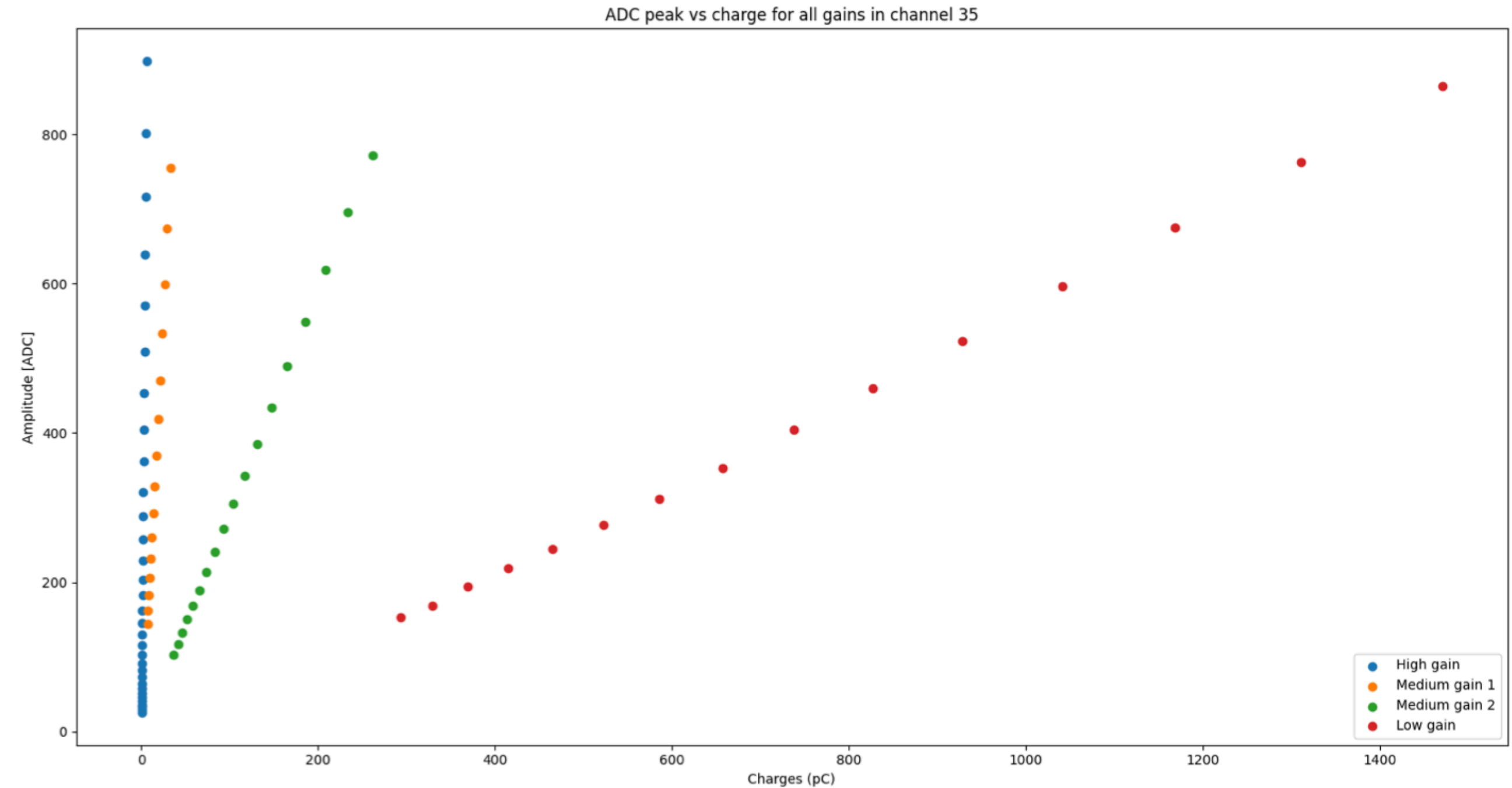

Noise study (related to timing measurement)

- ❑ Noise versus testboard layout:
 - ❑ Strong dependency with layer used for routing
 - ❑ 3 different configurations for input signals (PCB layout)

ASIC input #10 between GND and Digital supply

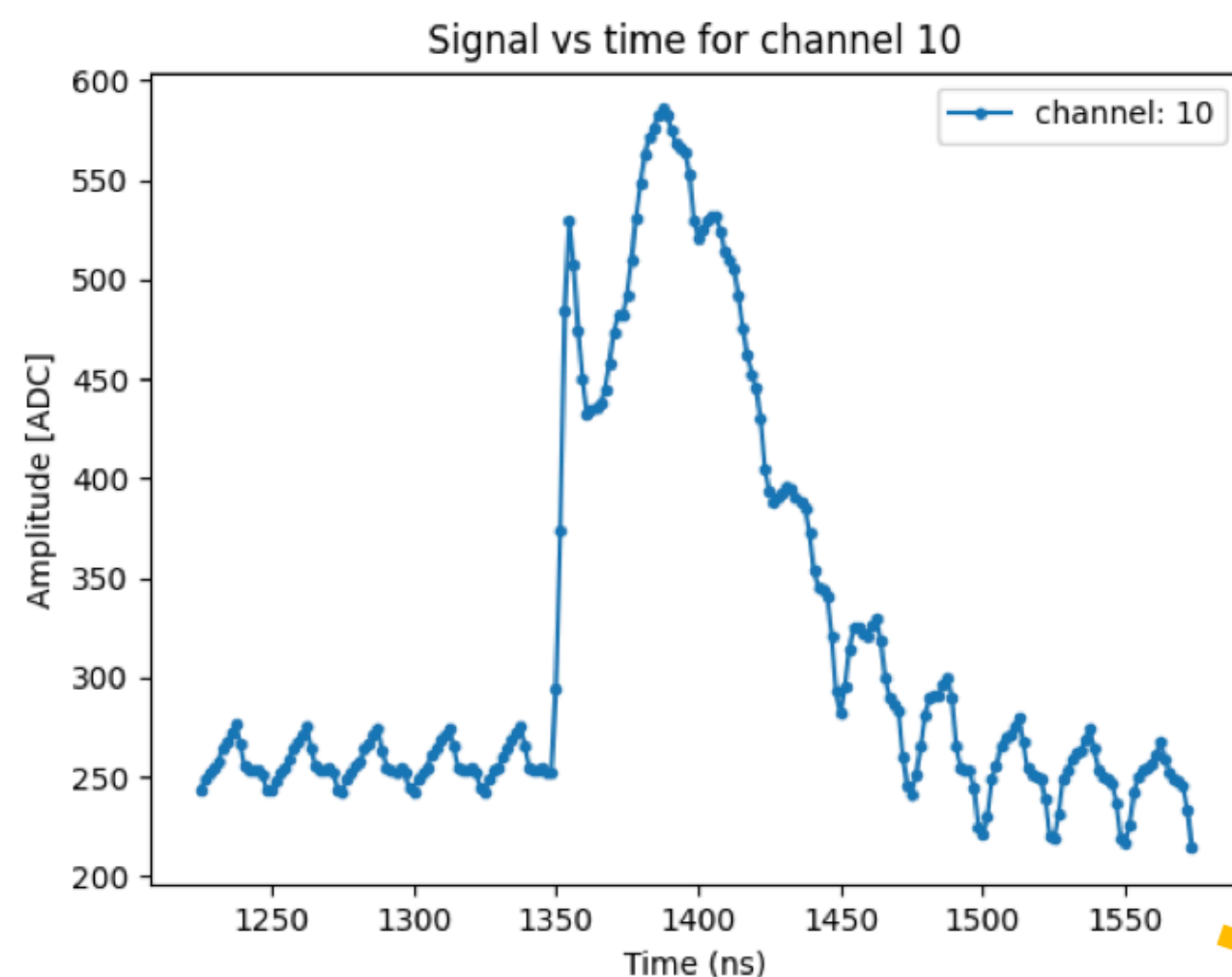

ASIC input #11 between GND and Analog supply

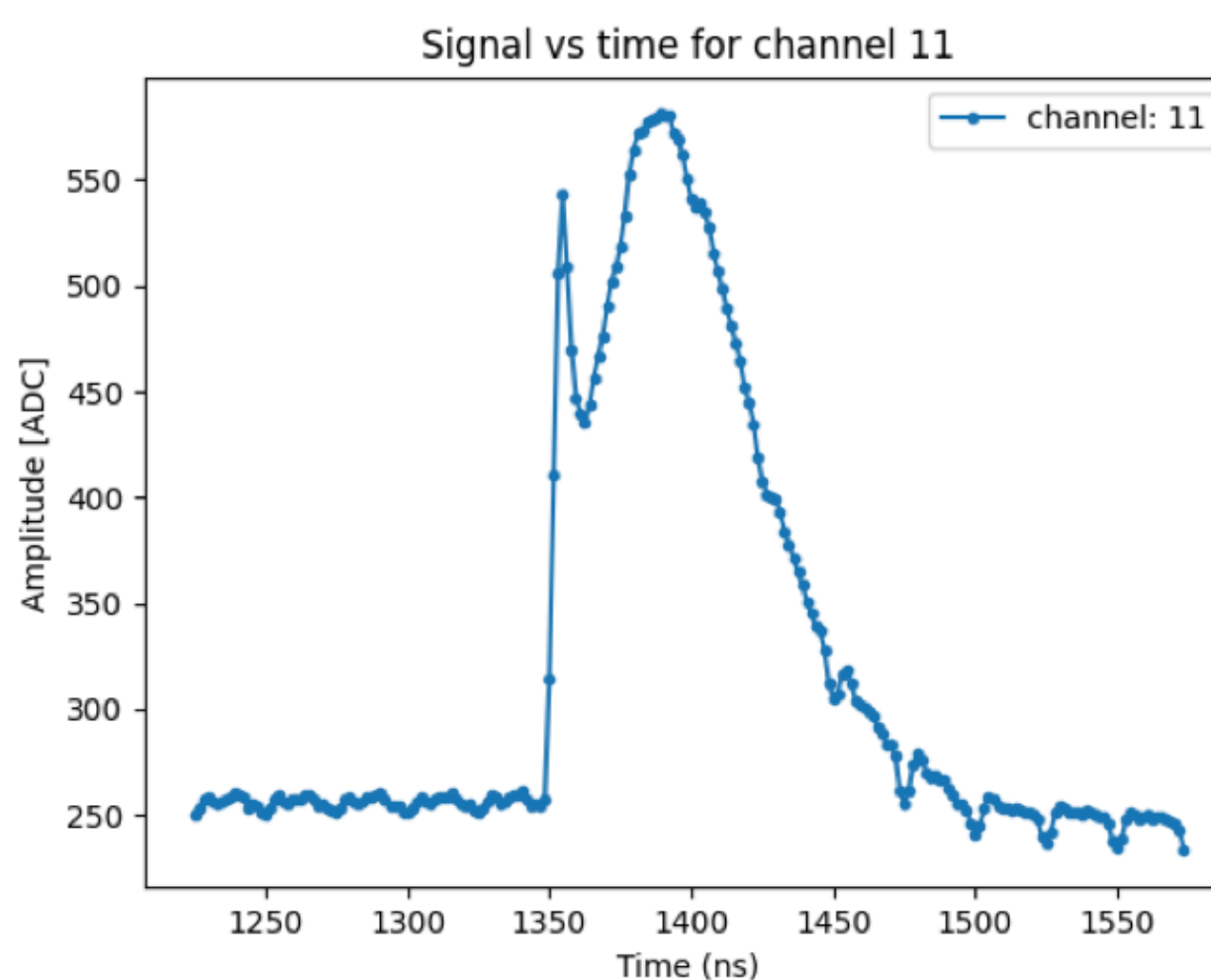

ASIC input #35 on top layer (between GND and "air")

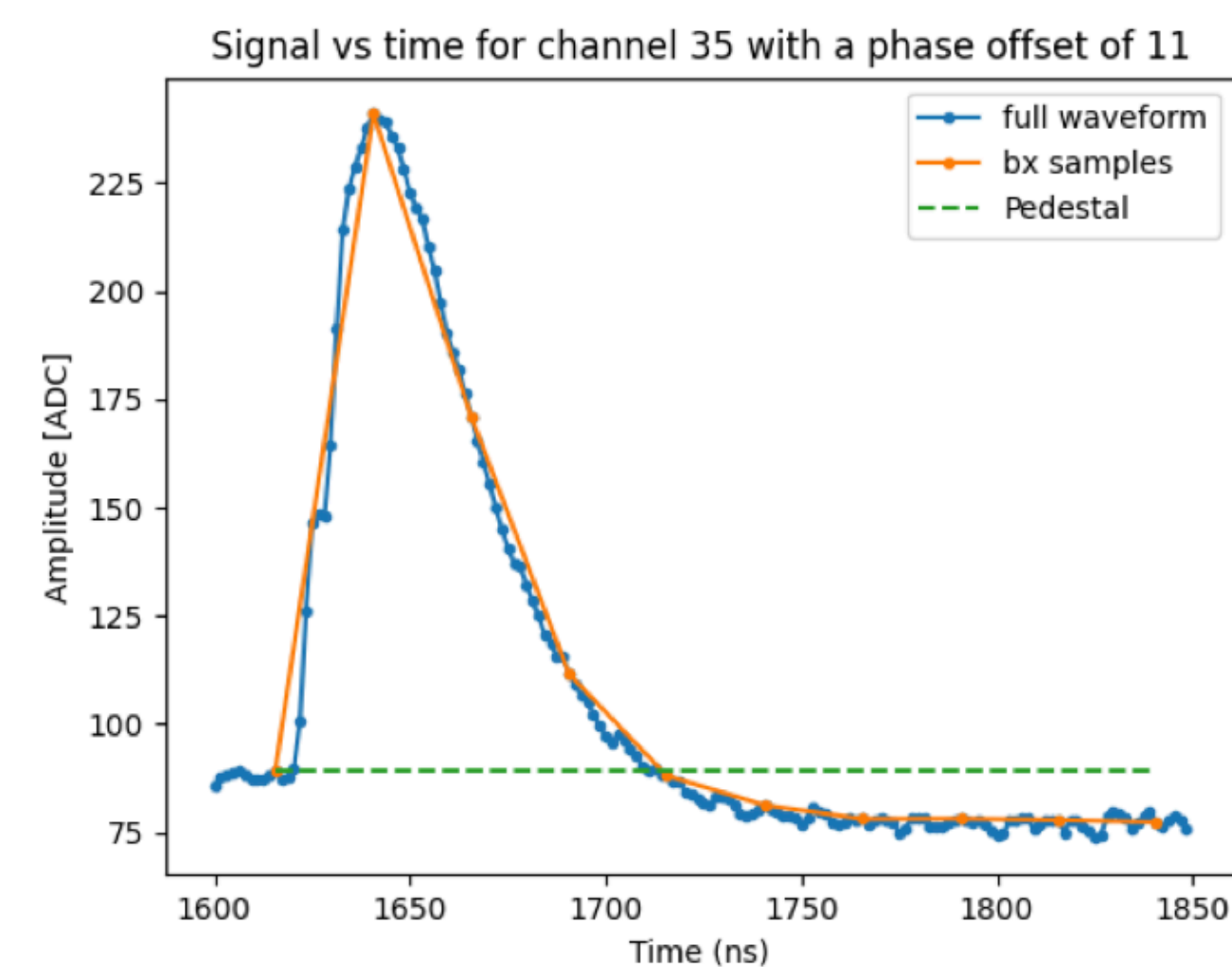

Noise divided by ~ 3

Divided by ~ 3

EIC 2026

Channel rate calculated with:

- ❑ Uniform distribution
- ❑ Worst case = always 1 channel readout over 18
 - ❑ Example with N=4 and
 - ❑ 2 separated in time hit → 40 words read out
 - ❑ 2 in-time hits → 24 words read out

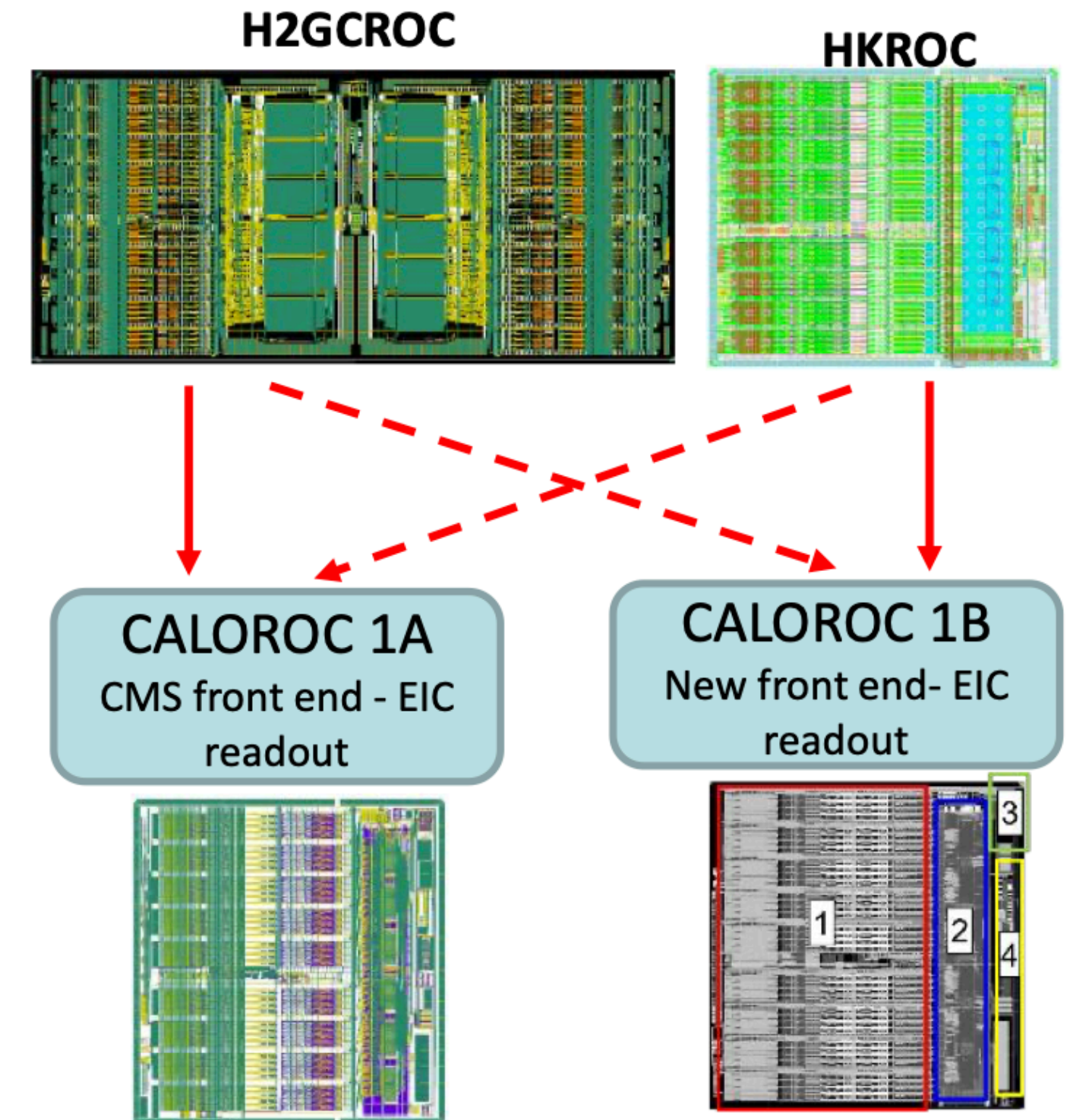
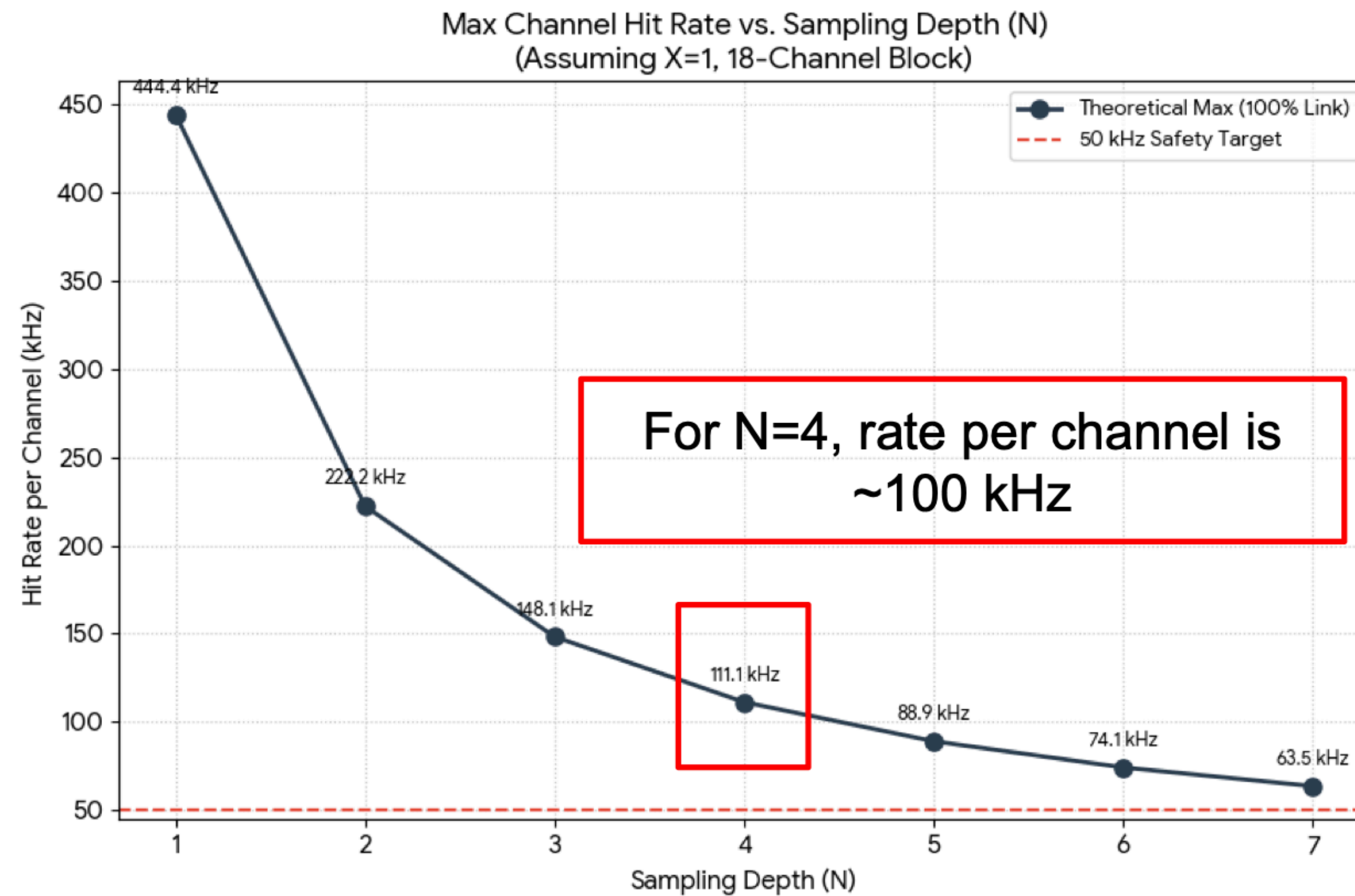

1. The Readout Model

$$T_{\text{readout}} = N \times (X + 4) \times 25 \text{ ns}$$

Full chain test

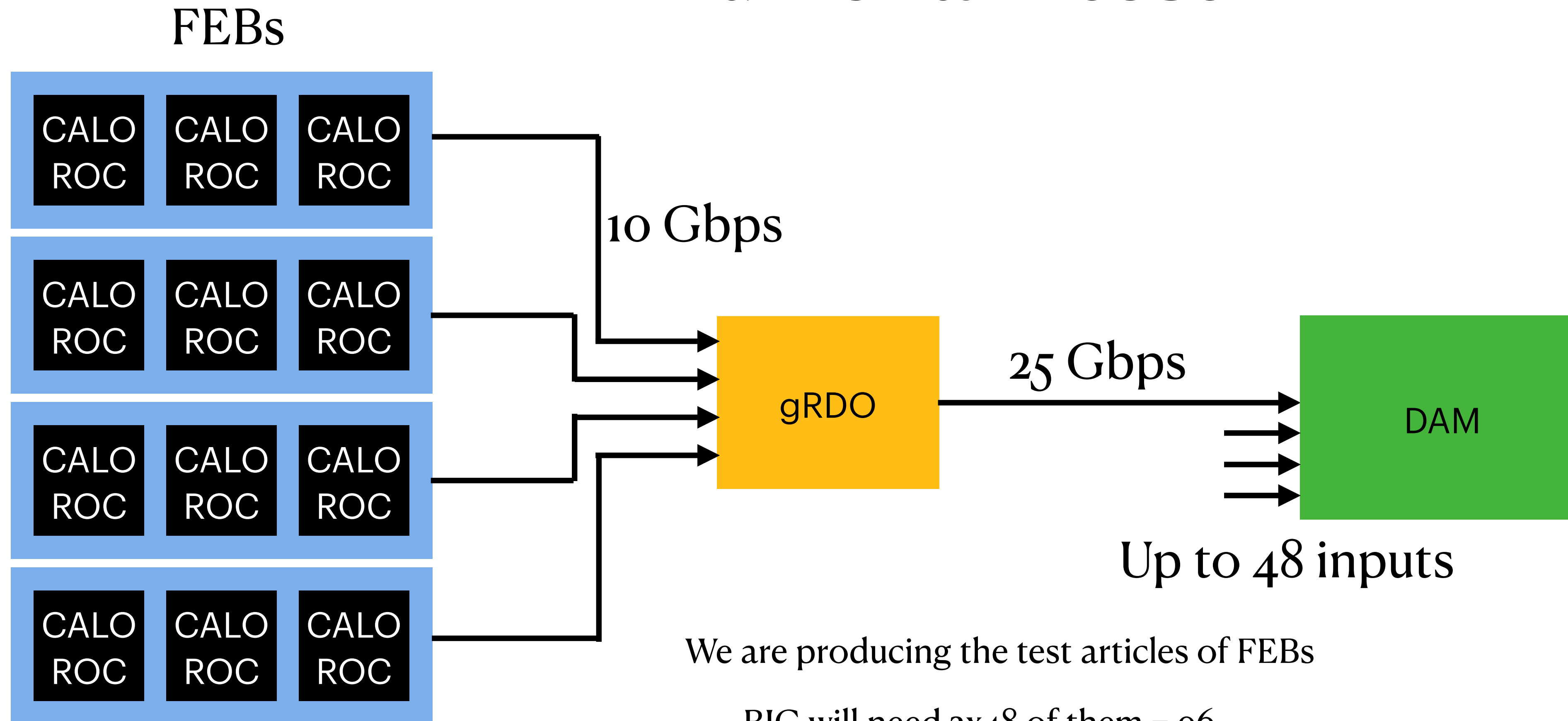

We are producing the test articles of FEBs

- BIC will need 2×48 of them = 96

Generic RDO is based on the Artix Ultrascale+:

- 4:1 ratio is required, BIC needs 24 of them

DAM board is the FELIX-155:

- BIC will occupy 1/2 of the FELIX

New H2GCROC board

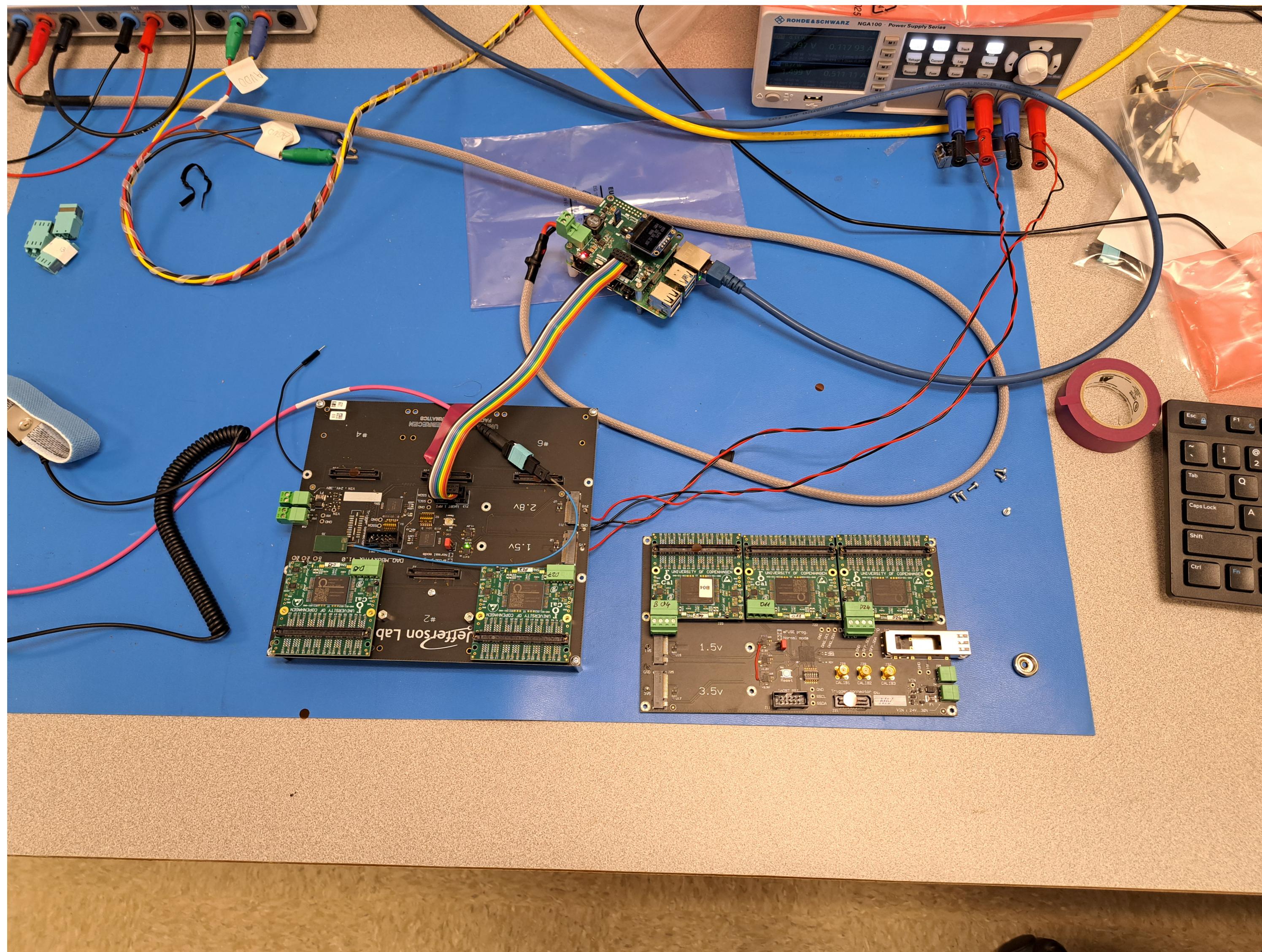

DAQ3:

- Prototype for the FEB
- Modular, so it can be tested with multiple detectors
- LpGBT and SFP+ for readout

DAQ6:

- Same as the previous one, just accepts 6 mezzanines
- VTRX+ for readout

New CALOROC test article

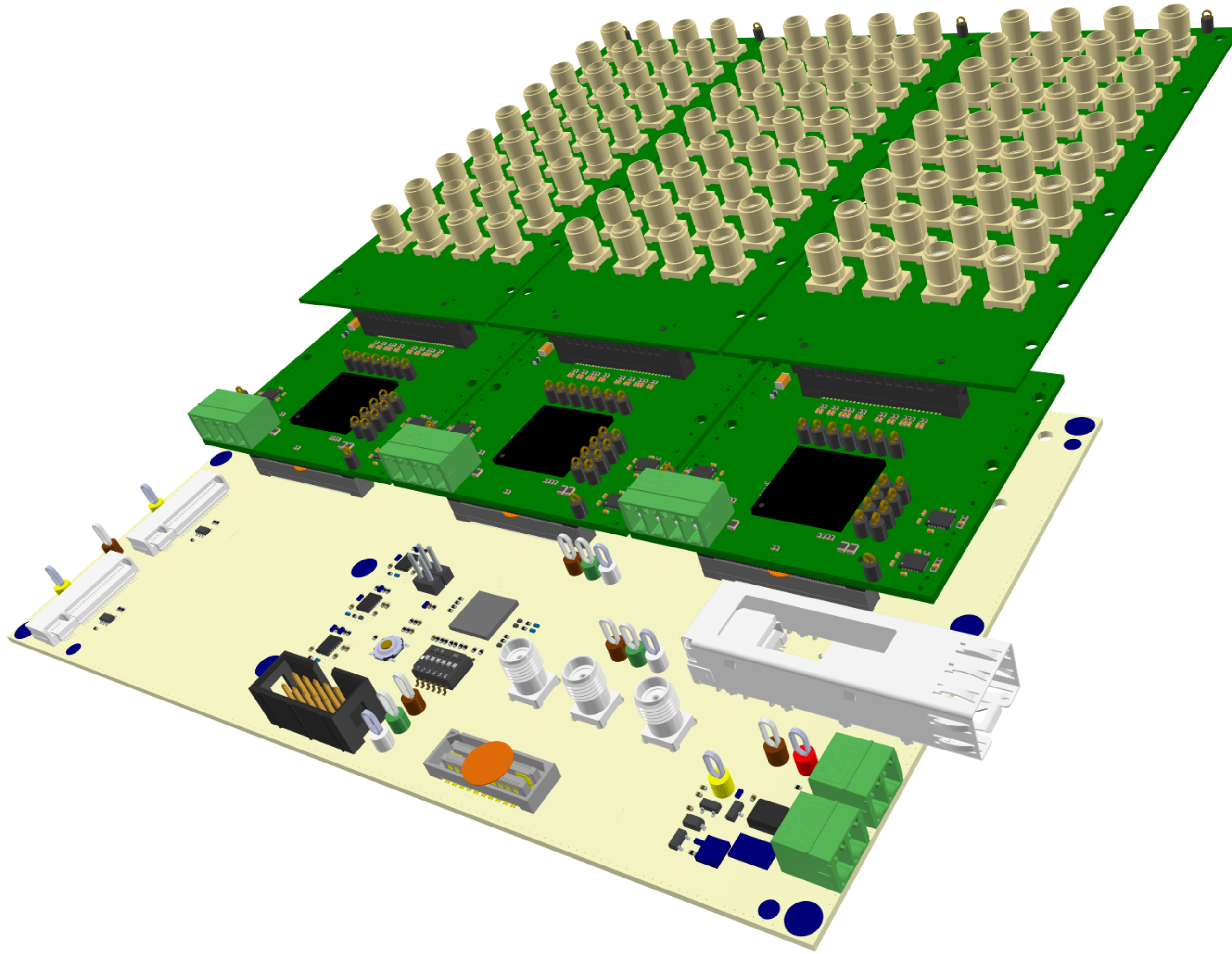

Design is ready to go:

- 2 CALOROC_{1A}'s are in our hands
- 3 CALOROC_{1B}'s are in our hands
- Money is coming from JLab to produce these
- Each board is already designed, ready to go

gRDO

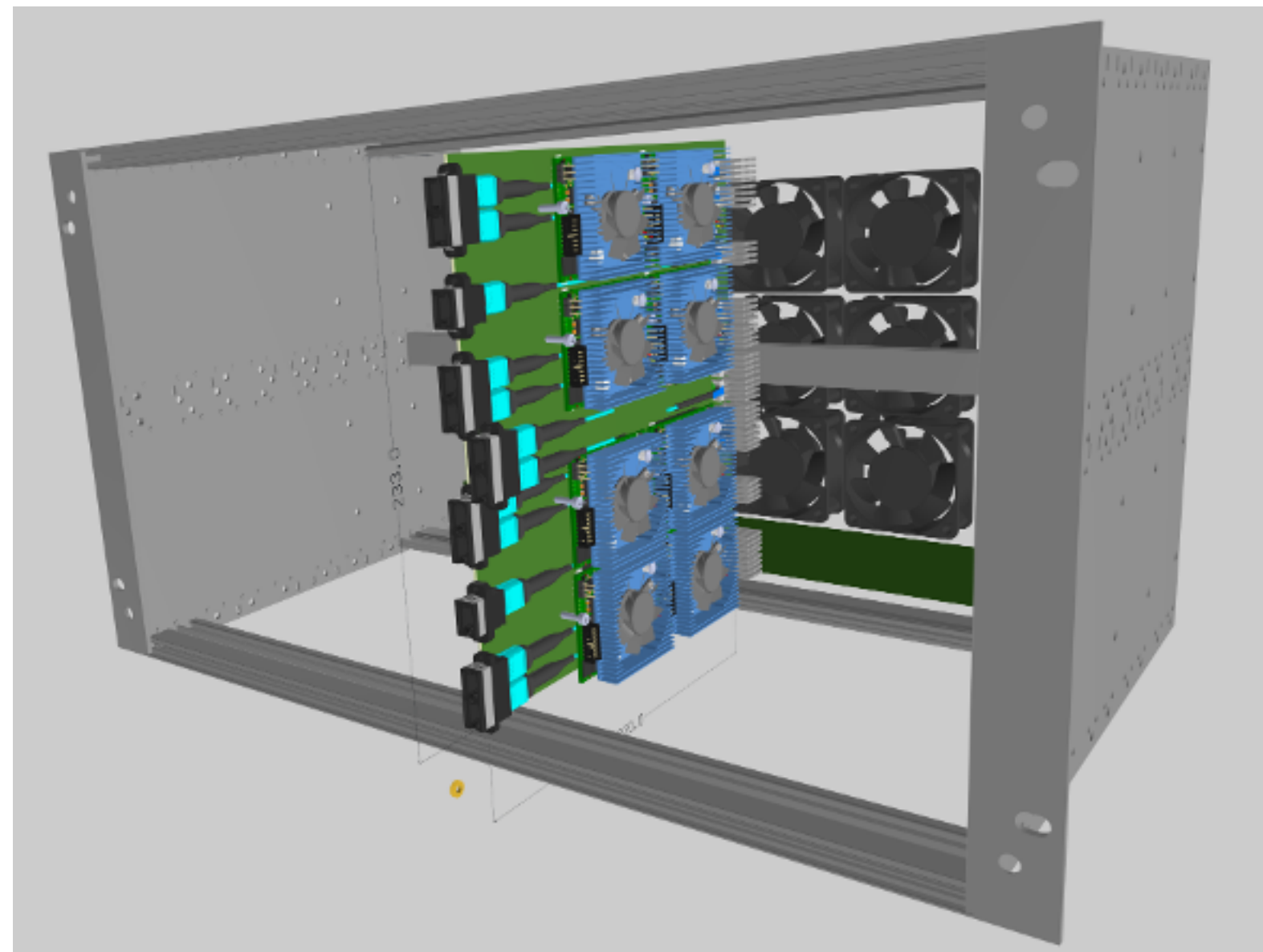
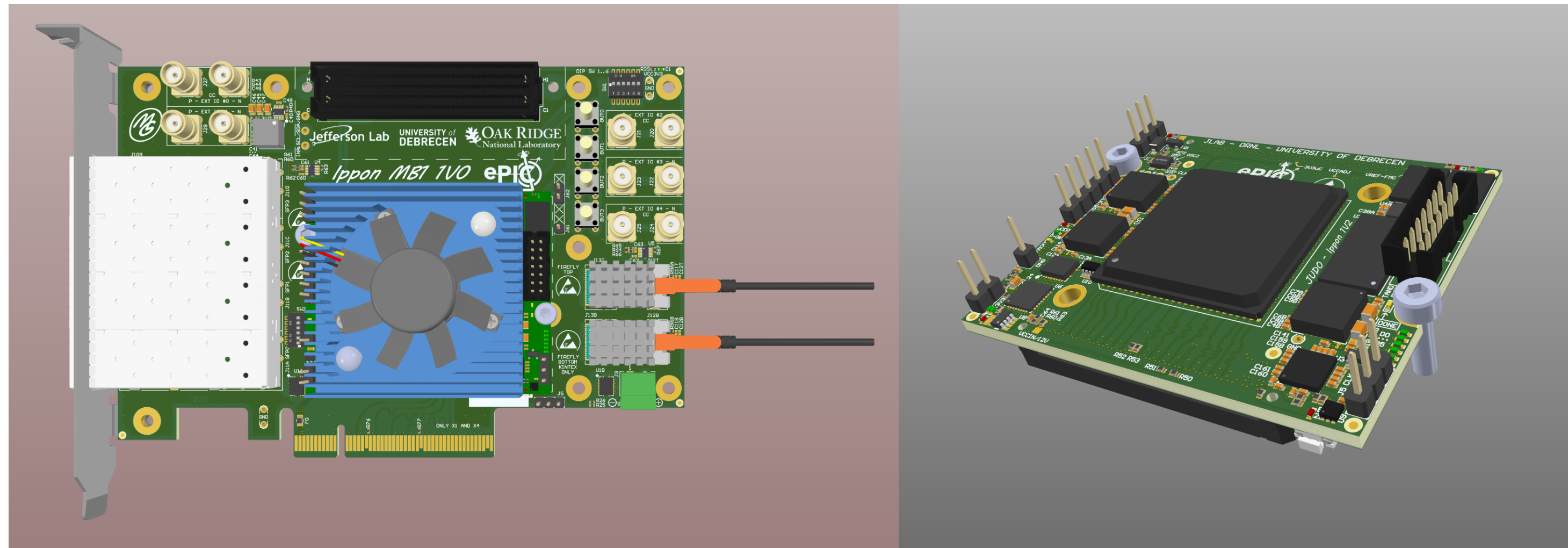

- The gRDO mezzanine is designed, ready for production
- The first mother board is ready for production:
 - Firefly added for SVT/other detectors
 - SFP+ is added too
 - FMC connector
 - PCIe
- First look also in the final arrangement in a crate:
 - 8 of these mezzanines can fit into a final gRDO board
 - Mezzanines from now can be reused in the final experiment

Setup

- This current mezzanine:
 - Maxed at 5A output current
 - Input/Output Voltage about 15-20 max
- Two mezzanines (third sent to Gerard):
 - One is a aircoil from CERN
 - One is a iron-powder thing
- DC/DC programable load
- Power Supply (max 2A input)
- Arduino to monitor everything, temperature, power
- Infrared camera, just to see the heat sources

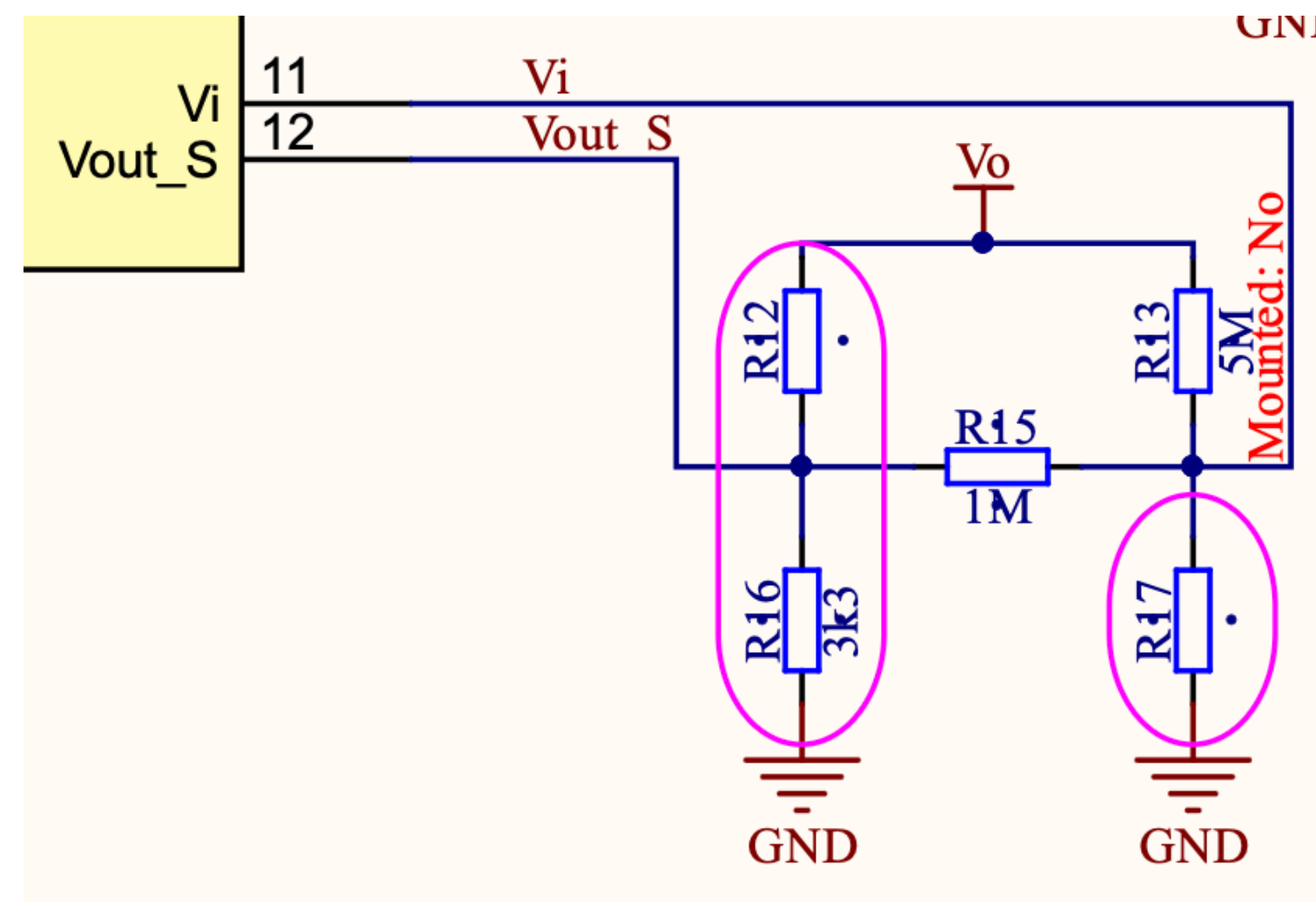
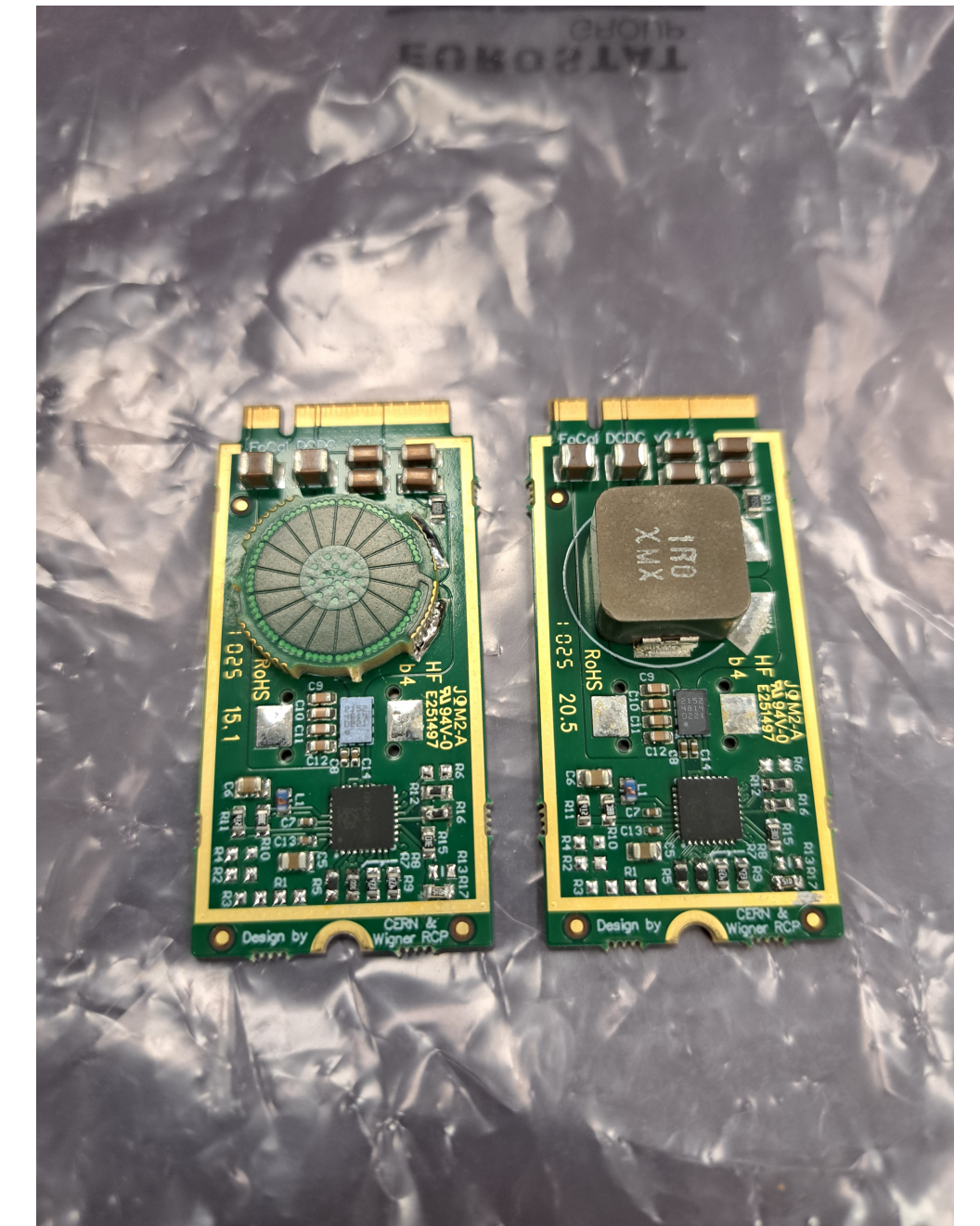
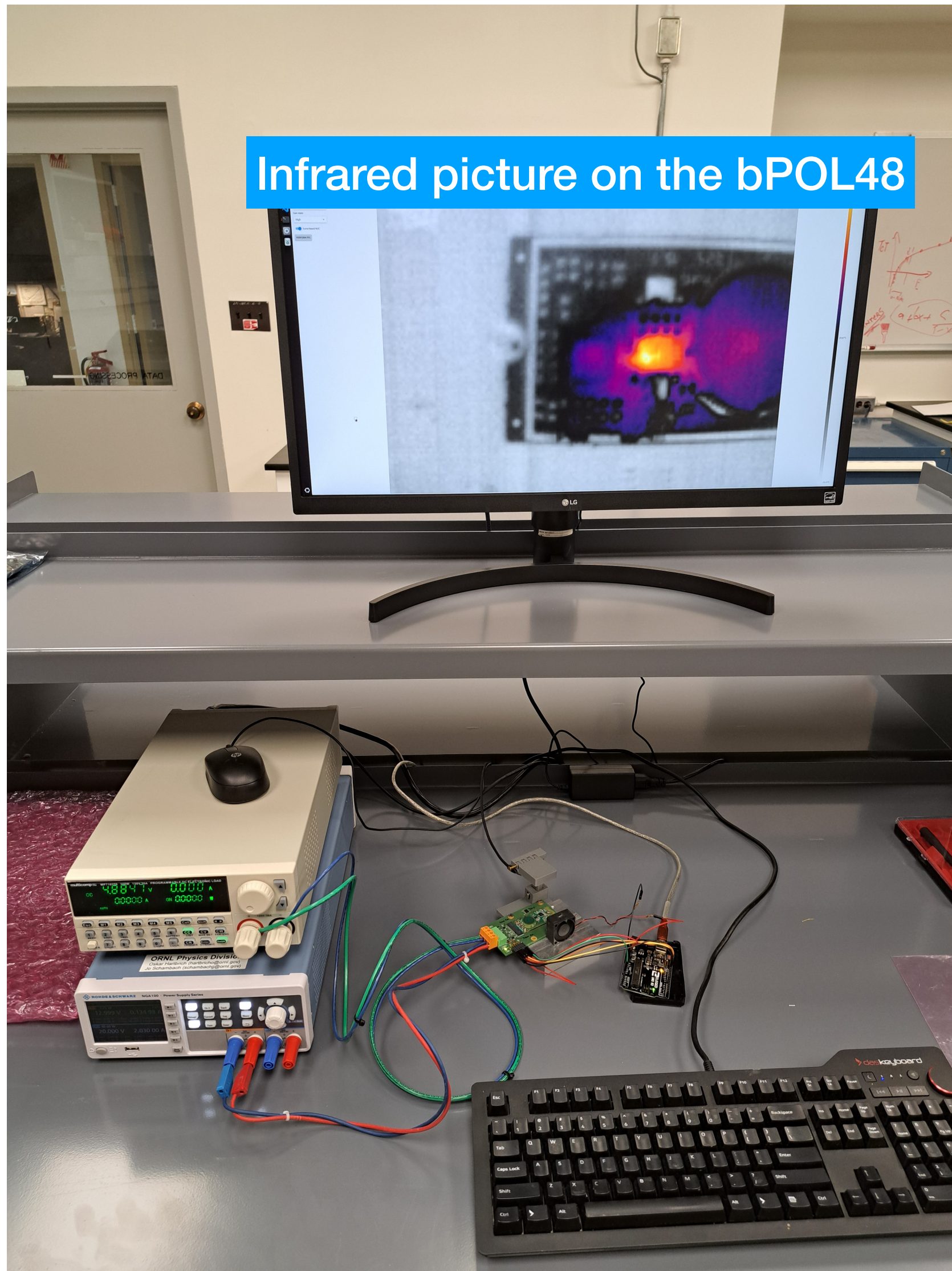

You can setup the output voltage with the resistors

Results - AirCoil 1V5

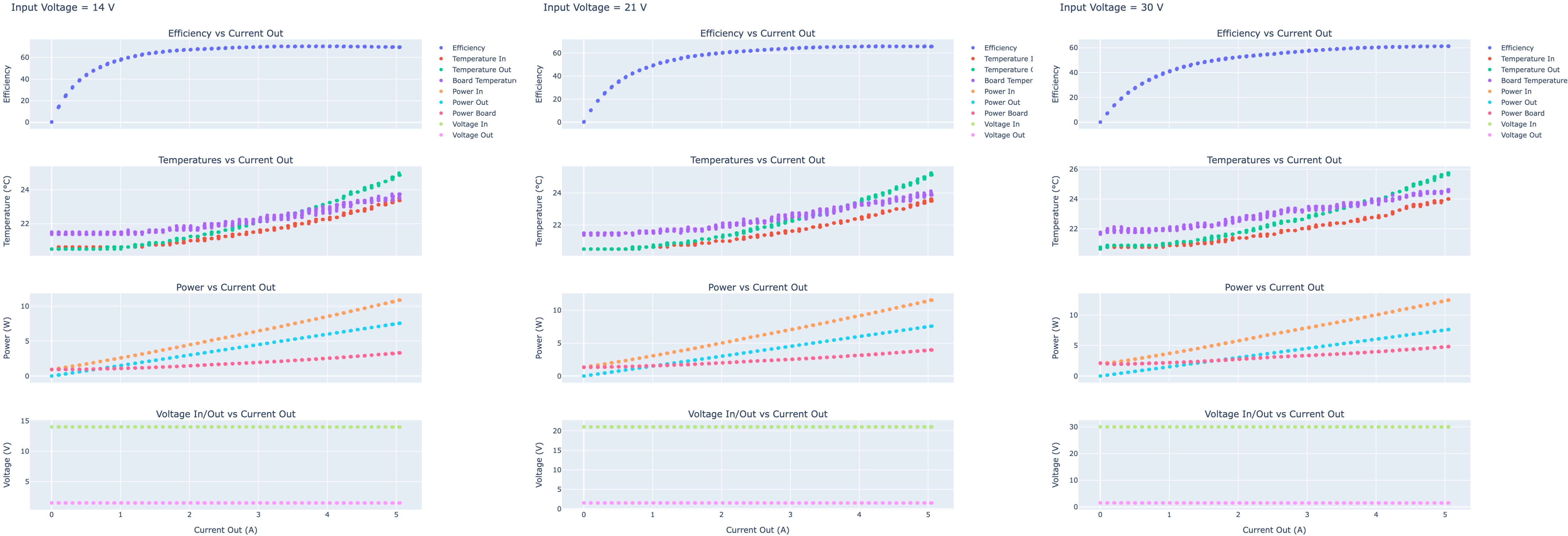

Initial tests show this was optimized for higher current > 3 A

Efficiency is about 70-80%, we plan to study this further this year

Table of measurements

Ferrite/Aircoil

Output	Input	1A	2A	3A	4A
4.8V	14 V	80/-	85/-	88/-	89/-
	25 V	65/-	76/-	80/-	-/-
	40 V	52/-	66/-	72/-	76/-
3.6 V	14 V	71/67	81/79	83/82	-/82
	23 V	60/60	72/73	77/77	-/79
	33 V	50/54	64/68	71/73	74/74
2.7 V	14 V	66/52	77/76	80/79	82/79
	25 V	51/56	65/69	71/73	75/74
	30 V	45/53	61/69	68/71	71/72
1.5 V	14 V	52/58	65/67	70/70	72/72
	21 V	44/50	57/60	63/64	65/66
	30 V	40/41	53/53	60/58	63/60

Summary

- CALOROC exists - finally
 - We are ready for some test production. Waiting for the money... should be on the way
 - We received 1A and 1B both
 - DAQ boards are ready, interface boards are ready
 - Producing 50 mezzanines for future chips also (not populated yet) - later this year we should get more chips
- RDO design is done:
 - Waiting for money - same money, should be on the way
- Full chain test:
 - Coming soon
- DC/DC converters:
 - Design is coming, we can produce some new ones this year

For discussion - FEB

