



Hit and channel rates in MPGD detectors with backgrounds

F. Bossù on behalf of the MPGD DSC
March 30th 2026

MPGD rates



What is simulated:

- One DIS event $Q^2 > 1 \text{ GeV}^2$ per event (either on average or forced)
- $2 \mu\text{s}$ equivalent of background hits merged to every DIS event
- Either $5 \mu\text{m}$ or $10 \mu\text{m}$ gold coating of the beam pipe

Simulations are accessible via xrootd (or on JLab /volatile)

```
epic:/RECO/25.12.0/epic_craterlake/Bkg_Exactly1SignalPer2usFrame/GoldCoating/5um/DIS/NC/10x275/minQ2=1
epic:/RECO/25.12.0/epic_craterlake/Bkg_Exactly1SignalPer2usFrame/GoldCoating/10um/DIS/NC/10x275/minQ2=1
epic:/RECO/25.12.0/epic_craterlake/Bkg_Exactly1SignalPer2usFrame/GoldCoating/5um/DIS/NC/10x100/minQ2=1
epic:/RECO/25.12.0/epic_craterlake/Bkg_Exactly1SignalPer2usFrame/GoldCoating/10um/DIS/NC/10x100/minQ2=1
```

Methodology:

- The readout is (still) a pixel grid of $150 \times 150 \mu\text{m}^2$
- Fill histograms in z or R, with 1 cm wide bins.
- Take the maximum, divide by the annular (or cylindrical) area to estimate the Hz/cm²
- Multiply by the readout strip area to get the Hz/channel

Remarks:

- No cluster size considered all channel rates must be multiplied by a factor 3 or 4

ECT

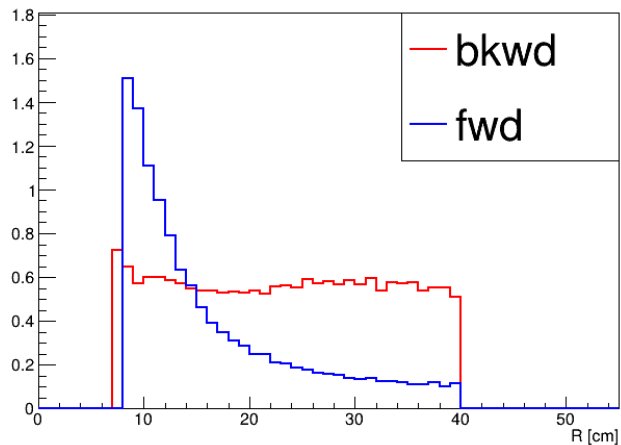

ECT Backward/Lepton Side from SIM

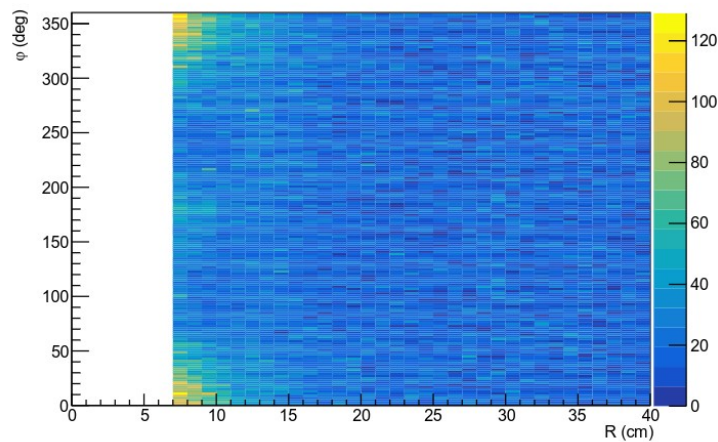

ECT Forward/Hadron Side AA cut

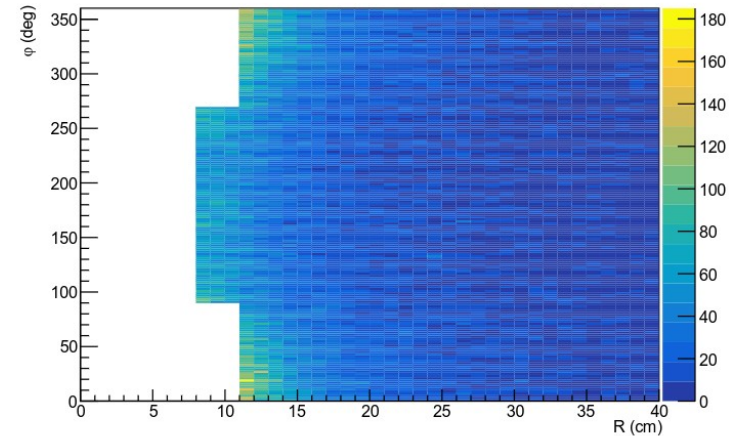

	Backward/Lepton	Forward/Hadron
Hottest Bin Rate	20531 Hz/cm ²	19202 Hz/cm ²
Hottest Channel Rate	5681 Hz	4266 Hz

From S. Gramigna

Barrel

10x275

BOT

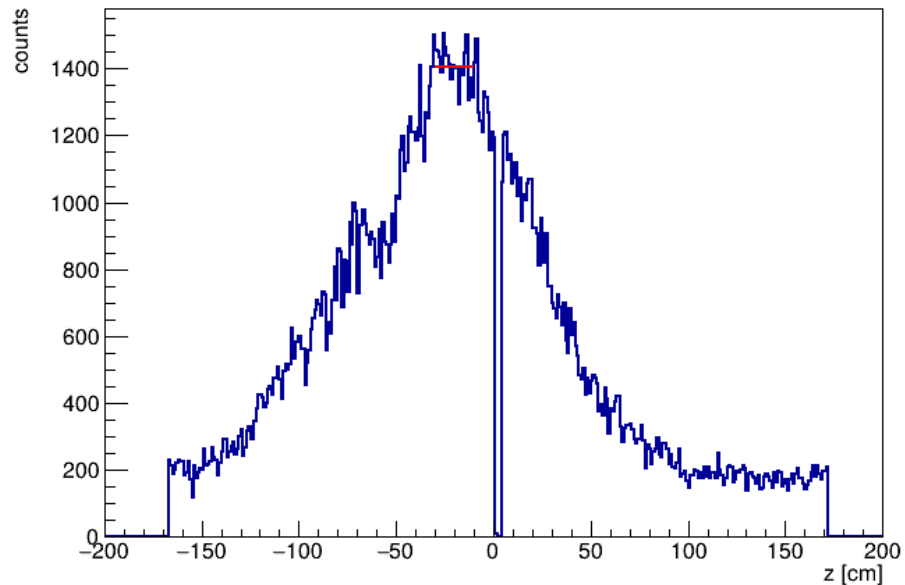

Strip area: 33cm x 1.13mm

	Hz/cm2	Hz/channel
BOT	2.65E+02	9.88E+02

CyMBaL

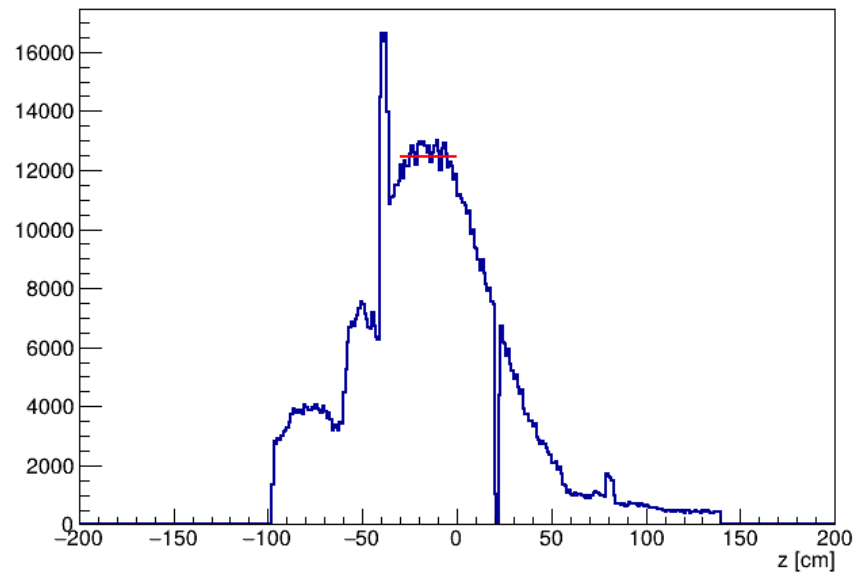

Strip area: 58cm x 1mm

	Hz/cm2	Hz/channel
CyMBaL	3.10E+03	1.80E+04

Salsa physics data rate : 40 MHz sampling

- Sampling period : 25 ns
- Signal shape ZS readout
 - 500 ns readout window when signal is above threshold
 - 200 ns peaking time
 - 20 samples
 - 13-word packet + 2-word link overhead

THIS IS AN EXAMPLE.

Sort of worst case scenario, if we need to read the whole signal shape

SALSA can be programmed:

- Number of samples
- Peaking time

Channel rate kHz	Channel BW Mbit/s	Salsa BW Mbit/s	Link load %	Comment
10	4.6	293	23	Initial value
20	9.2	586	46	Zone of comfort
25	11.4	732	57	
30	13.7	879	69	Uncomfortable
40	18.3	1172	92	Inacceptable

Summary

- Most of the rate in CyMBaL (and BOT) is given by the synchrotron radiation
- The rates in the forward ECT Disks are dominated by physics
- The increase of the gold coating from $5\mu\text{m}$ to $10\mu\text{m}$
 - rates in CyMBaL (and BOT) decrease by a factor ~ 2
 - for ECTs, decrease of 5%
- SALSA is being designed for rates higher than 100 kHz/channel \rightarrow no issues
- The limiting factor is the link SALSA-IpGBT. One can double it, but this has impacts on design of the chain, i.e. modified FEBs, more DAMs...
- TODO for the three MPGD systems:
 - Check if performances are OK with smaller number of samples (spatial and time res)
 - Currently the threshold in npsim for hit formations is 100 eV. To be checked again.

Sources: MC Particle level

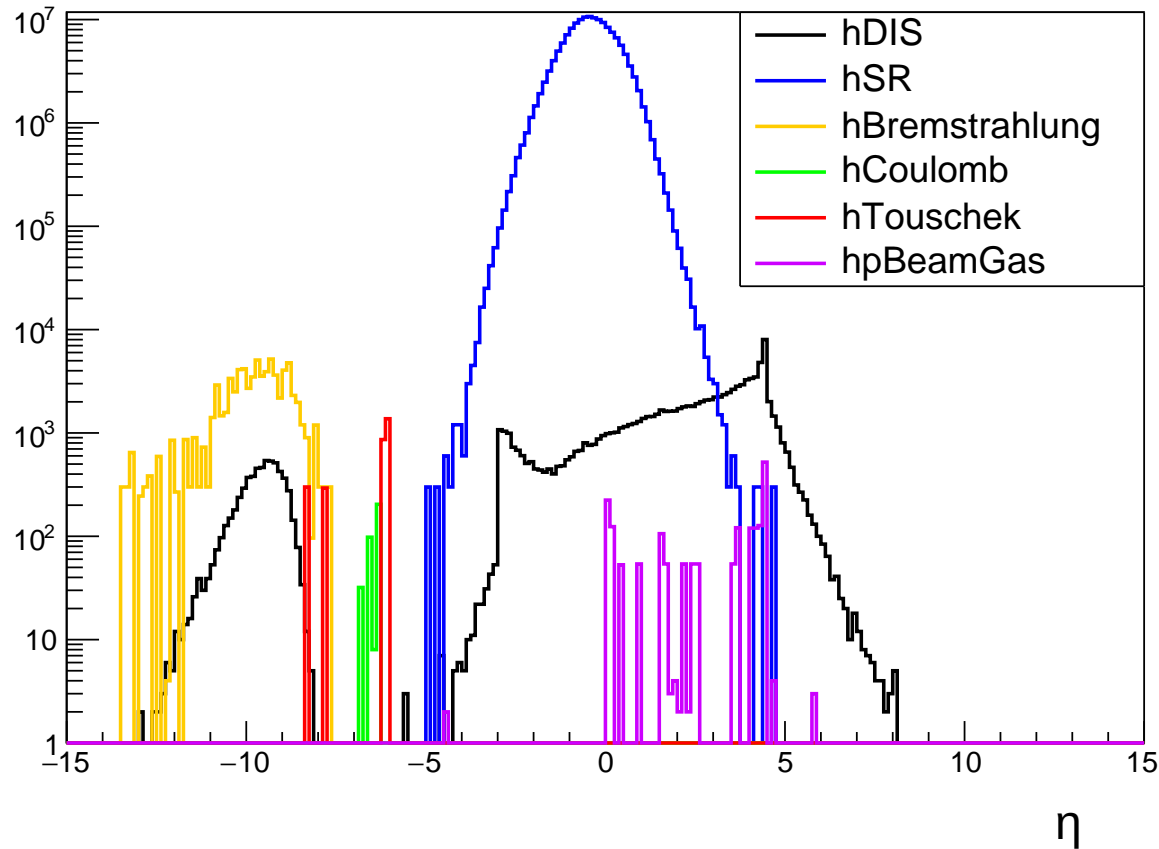

e-p 10 GeV x 100 GeV

Synchrotron radiation
dominates at mid rapidity

ECT



10 μ m

5 μ m

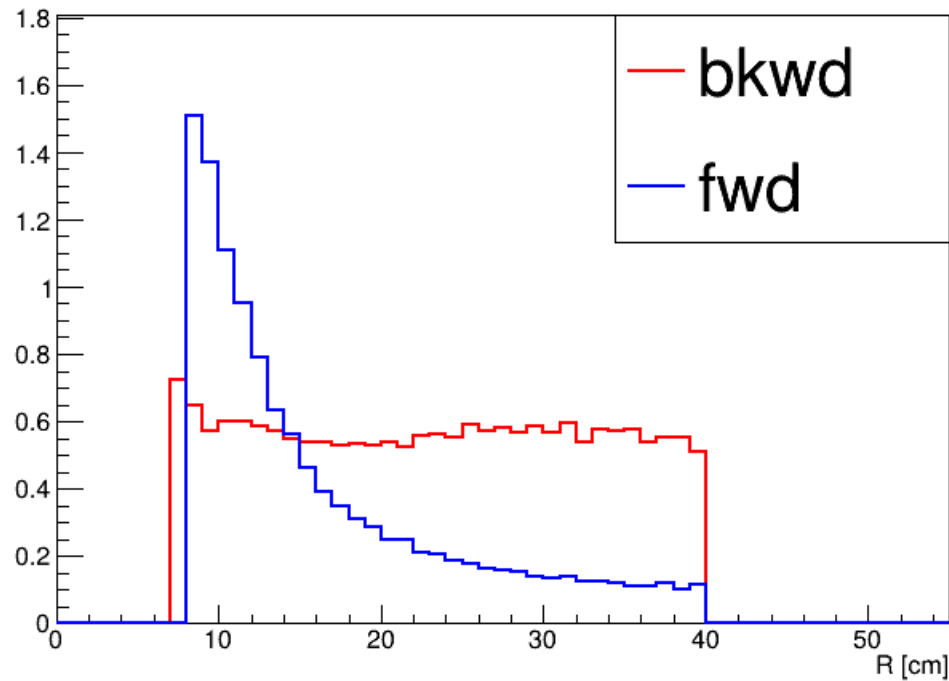
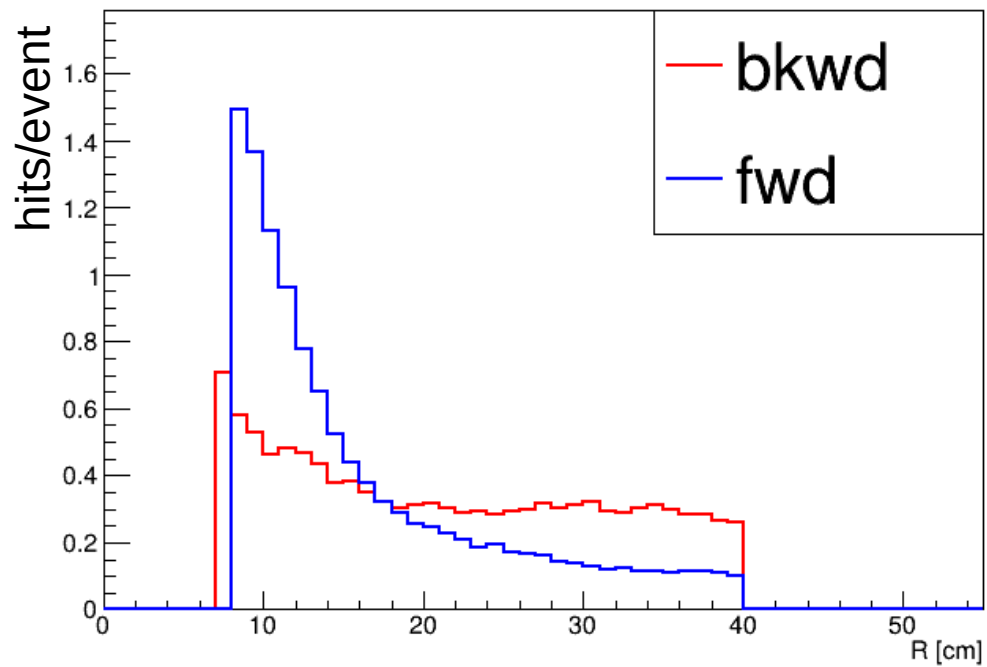

CyMBaL

10x275

w/o background

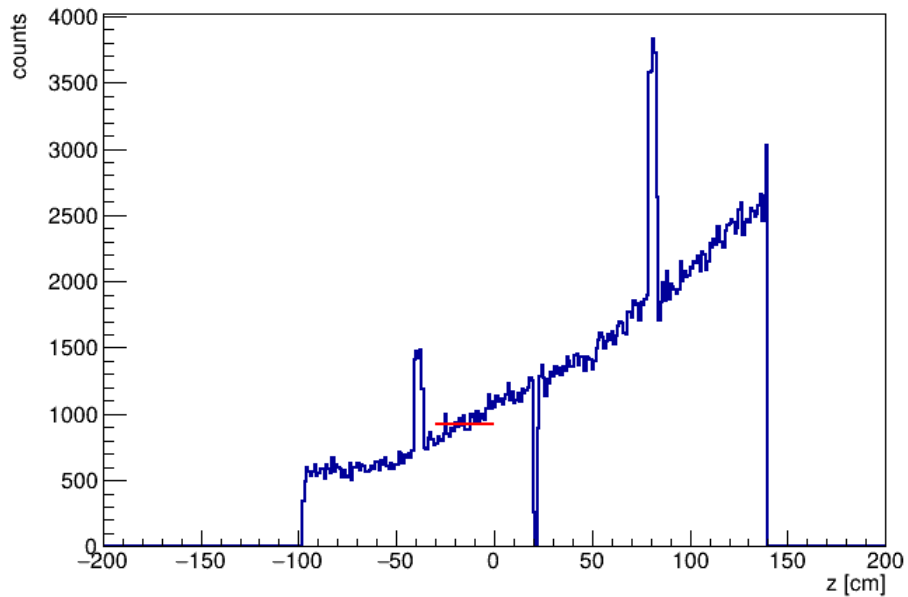

w/ background

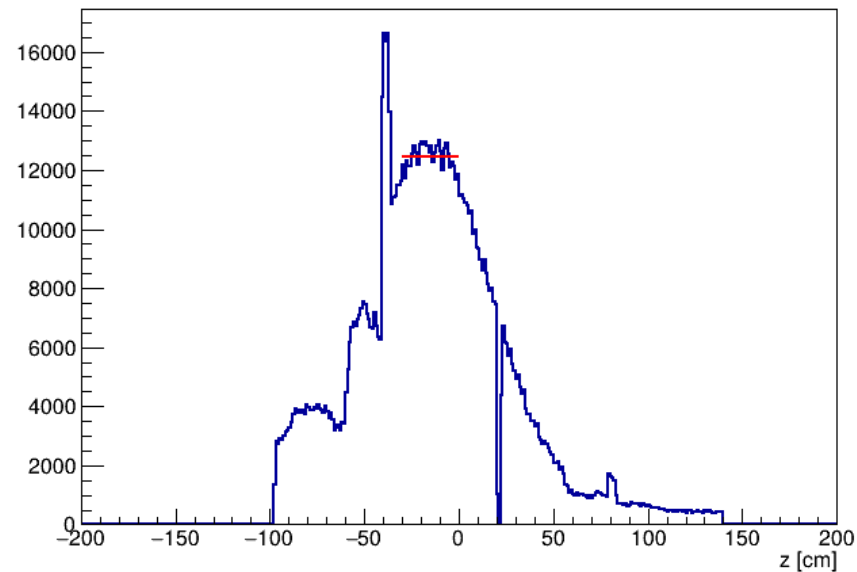

Strip area: 58cm x 1mm

	Hz/cm2	Hz/channel
CyMBaL	1.95E+01	1.13E+02

	Hz/cm2	Hz/channel
CyMBaL	3.10E+03	1.80E+04

BOT

10x275

w/o background

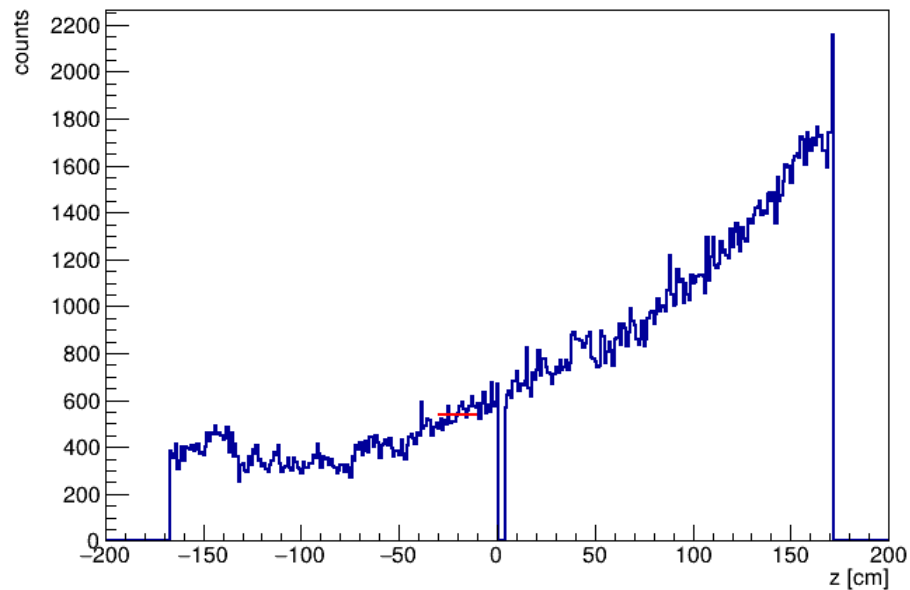

w/ background

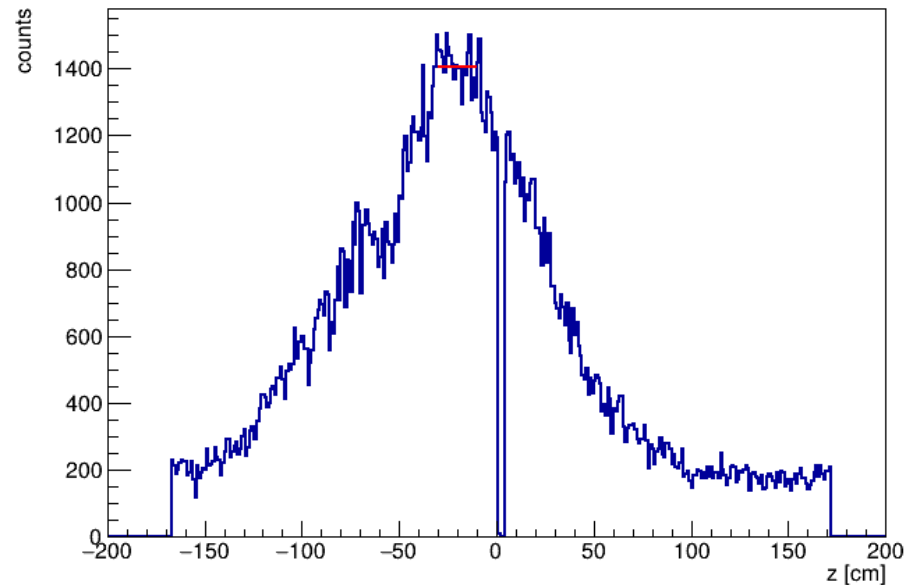

Strip area: 33cm x 1.13mm

	Hz/cm2	Hz/channel
BOT	8.58E+00	3.20E+01

	Hz/cm2	Hz/channel
BOT	2.65E+02	9.88E+02

5 μ m



	10x275		10x100	
	Hz/cm2	Hz/channel	Hz/cm2	Hz/channel
CyMBaL	3.10E+03	1.80E+04	3.10E+03	1.80E+04
BOT	2.65E+02	9.88E+02	2.61E+02	9.73E+02
ECT Backward Near	6.77E+03	1.67E+04	6.14E+03	1.51E+04
ECT Backward Far	6.78E+03	1.67E+04	6.06E+03	1.49E+04
ECT Forward Near	1.26E+04	3.11E+04	1.27E+04	3.12E+04
ECT Forward Far	1.34E+04	3.30E+04	1.35E+04	3.33E+04

10 μ m



	10x275		10x100	
	Hz/cm2	Hz/channel	Hz/cm2	Hz/channel
CyMBaL	1.67E+03	9.69E+03	1.67E+03	9.68E+03
BOT	1.70E+02	6.35E+02	1.70E+02	6.34E+02
ECT Backward Near	6.63E+03	1.63E+04	5.99E+03	1.47E+04
ECT Backward Far	6.48E+03	1.59E+04	5.73E+03	1.41E+04
ECT Forward Near	1.25E+04	3.08E+04	1.24E+04	3.06E+04
ECT Forward Far	1.38E+04	3.39E+04	1.33E+04	3.27E+04

Construction parameters

- Channel data
 - 12-bit ADC samples
 - 2 samples per 32-bit word
 - 3-word channel overhead
 - Header, Trailer, Parity
- 64-channels per ASIC
- Single serial TX data link per ASIC
 - 1.28 Gbit/s bandwidth
 - Two 32-bit words of overhead after each packet
 - Idle words

Channel packet

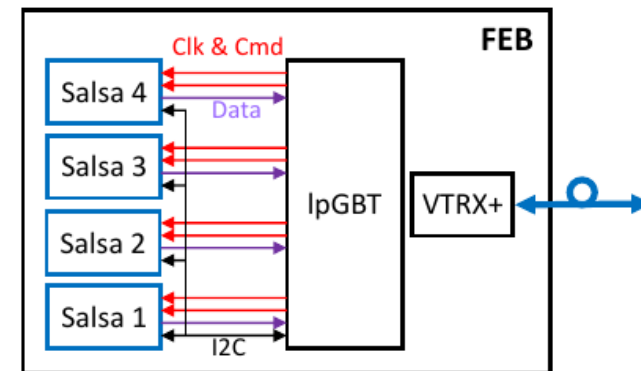
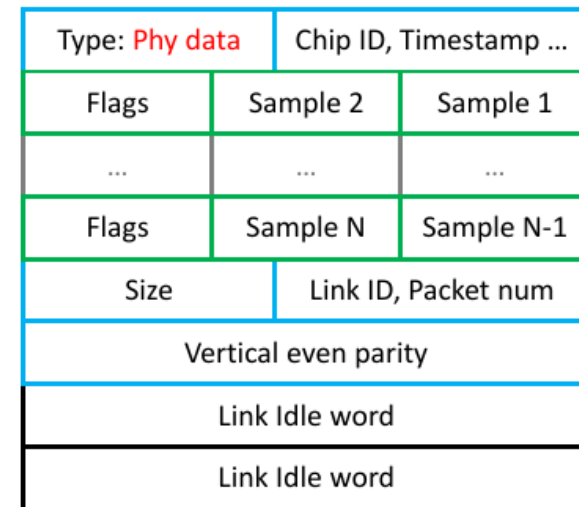

Salsa physics data rate : 50 MHz sampling

- Sampling period : 20 ns
- Signal shape ZS readout
 - 500 ns readout window when signal is above threshold
 - 200 ns peaking time
 - 25 samples
 - 16-word packet + 2-word link overhead

Channel rate kHz	Channel BW Mbit/s	Salsa BW Mbit/s	Link load %	Comment
10	5.5	352	27	Initial value
20	11.0	703	55	Zone of comfort
25	13.7	879	69	Uncomfortable
30	16.5	1055	82	Inacceptable
40	22.0	1406	110	