

# pfRICH

Triple I Engineering Meeting Update  
Alex Eslinger

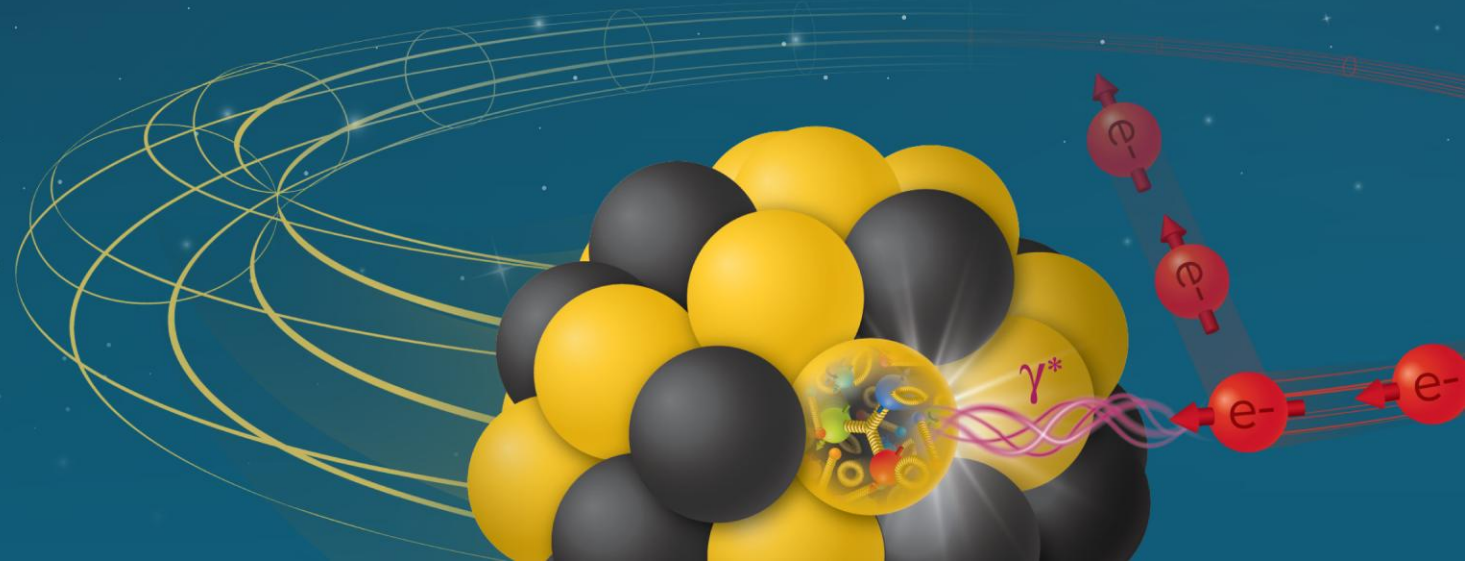

Electron-Ion Collider

# pfRICH: Overview

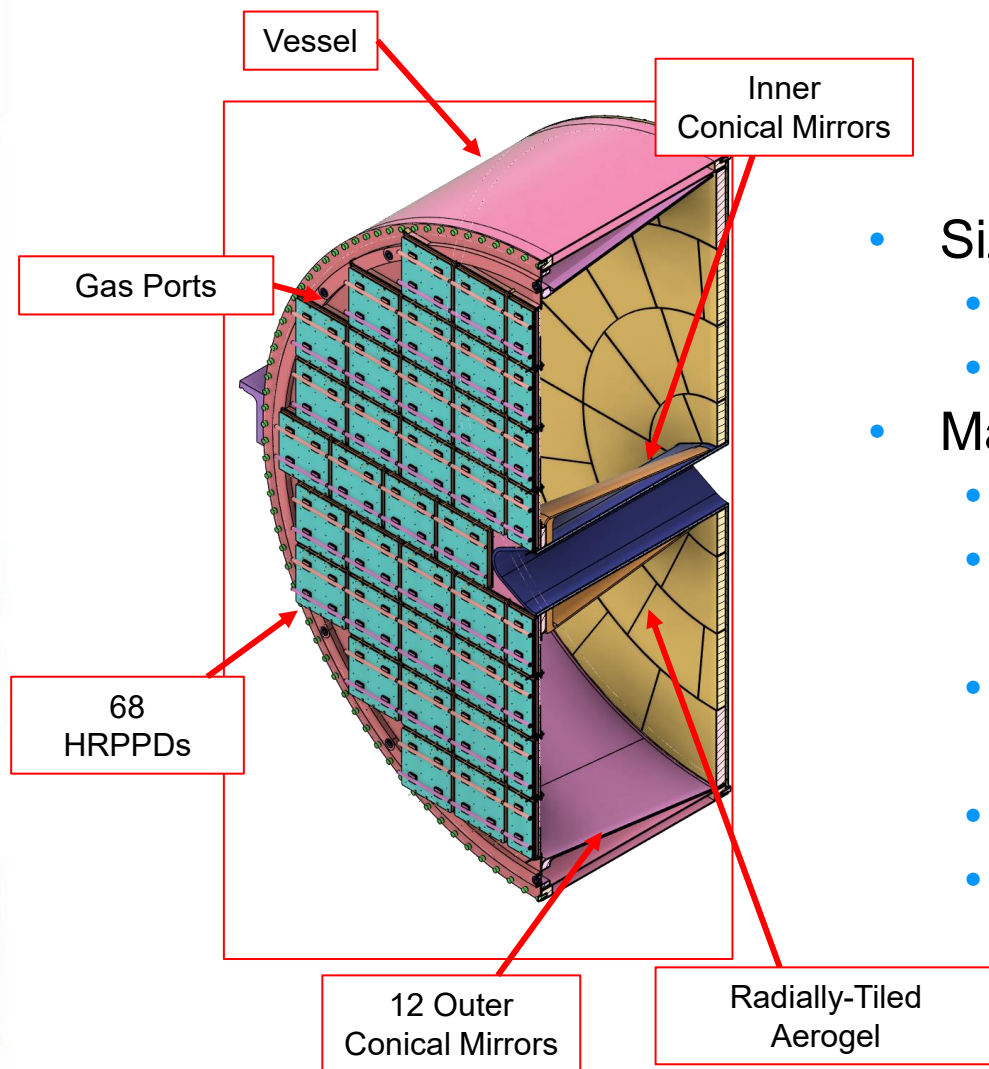

- Size and scale:
  - Outer Diameter: 130cm
  - Weight: ~200kg
- Major components:
  - Vessel
  - Sensor Plane with 68 HRPPDs
  - Aerogel Plane with radially-tiled aerogel
  - Inner Conical Mirrors
  - Outer Conical Mirrors

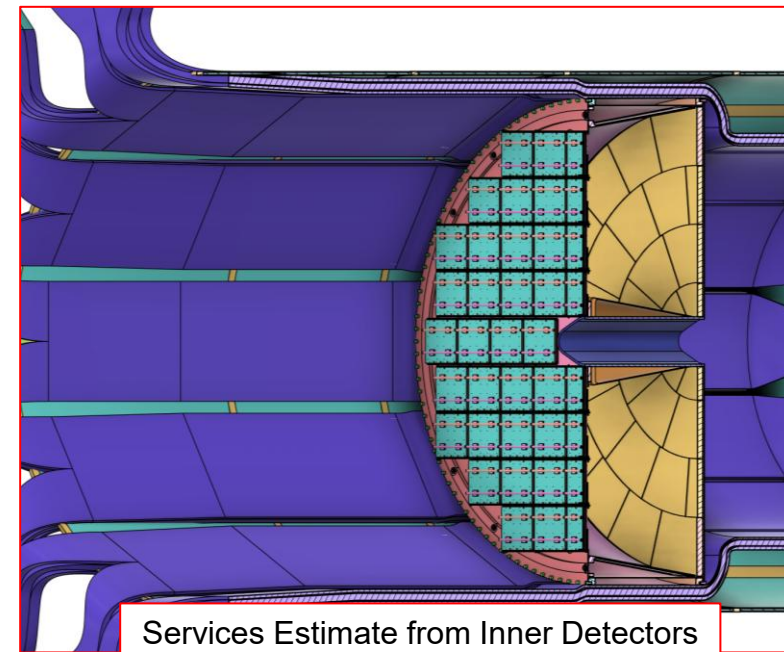
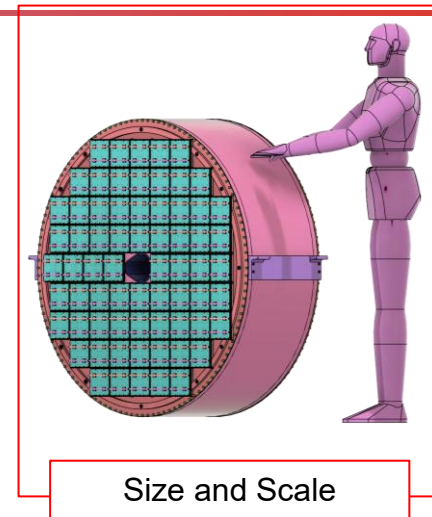

# pfRICH: Components (External)

- Prototyping has been ongoing for the various components to verify manufacturing techniques and validate the design
- Stony Brook University (SBU) and Purdue University have been working to create a full-scale prototype (and small-scale test prototypes)
- One of the design changes that came from this prototyping was the layering of the sensor plane (shown in the C-S view)

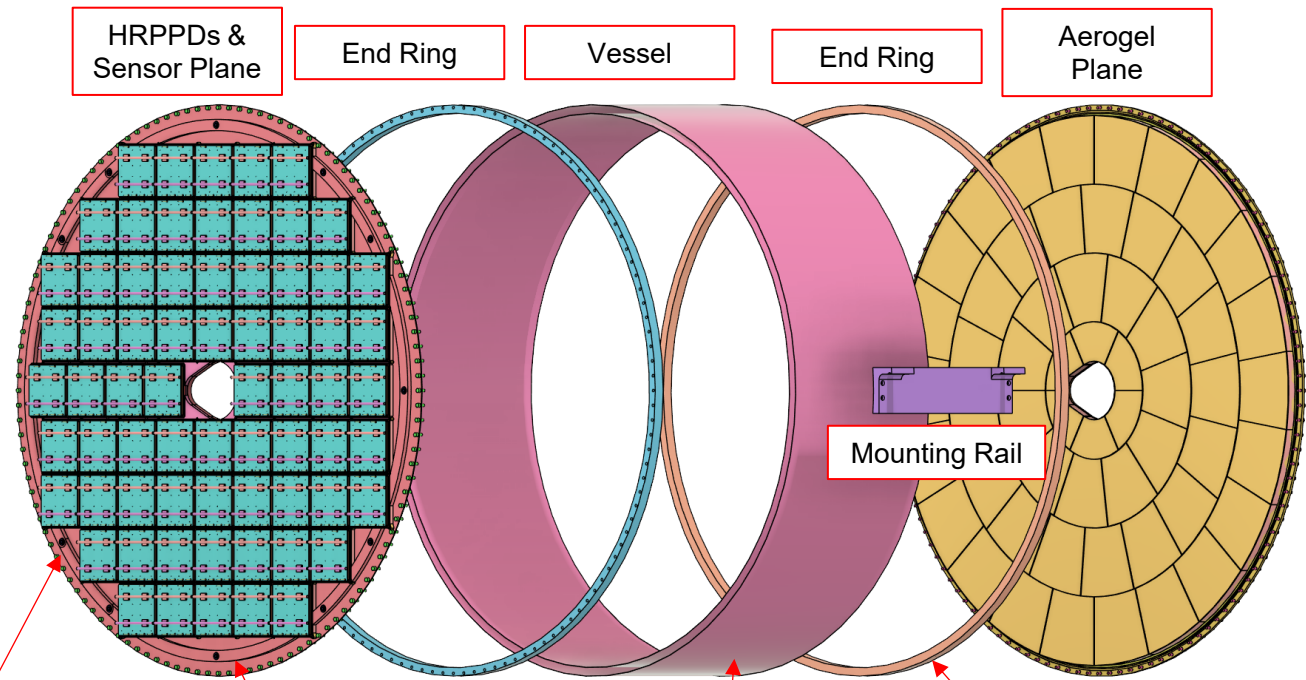

Prototyping the Sensor Plane (Purdue)

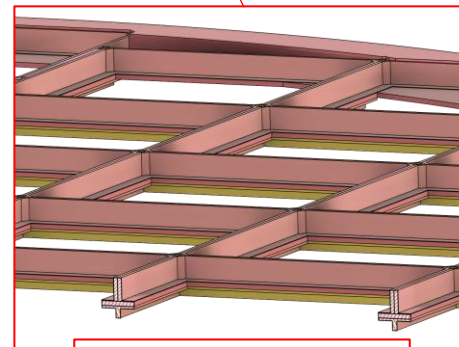

C-S of Sensor Plane

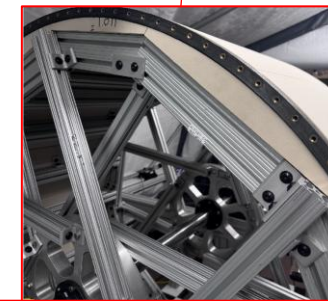

Prototyping the Vessel (SBU)



Prototyping the End Rings (Purdue)

# pfRICH: Components (Internal)

- **Internal components consist of:**
  - Conical Mirrors (Inner/Outer)
  - The central support tube
  - “Pyramid” Mirrors
  - Nitrogen gas hardware
  - Laser Monitoring System
- Inner and outer mirrors have been undergoing full scale prototyping
- Pyramid mirror design being considered for an engineering sample to confirm the design

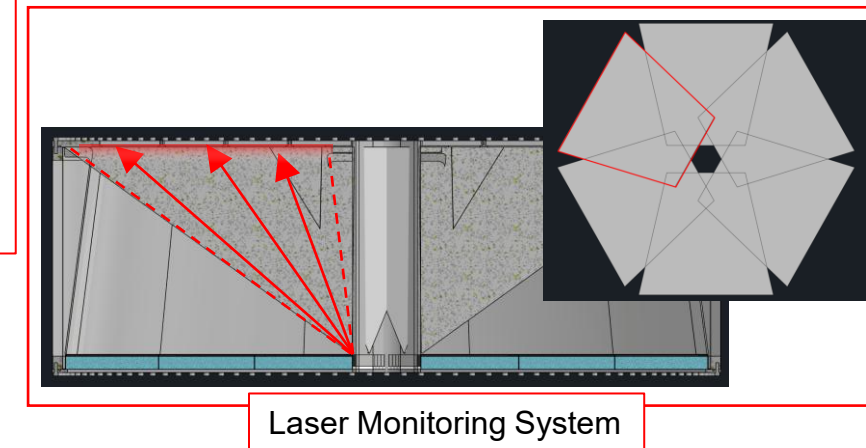
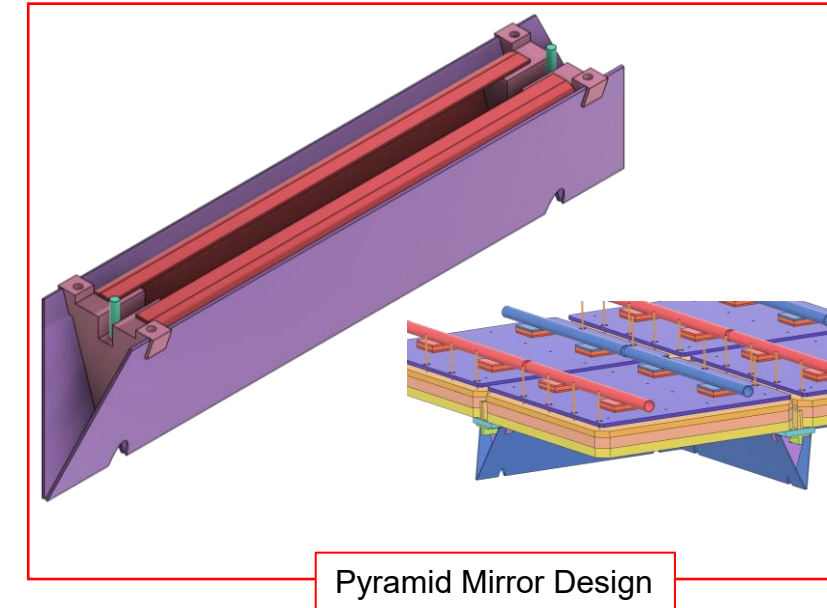
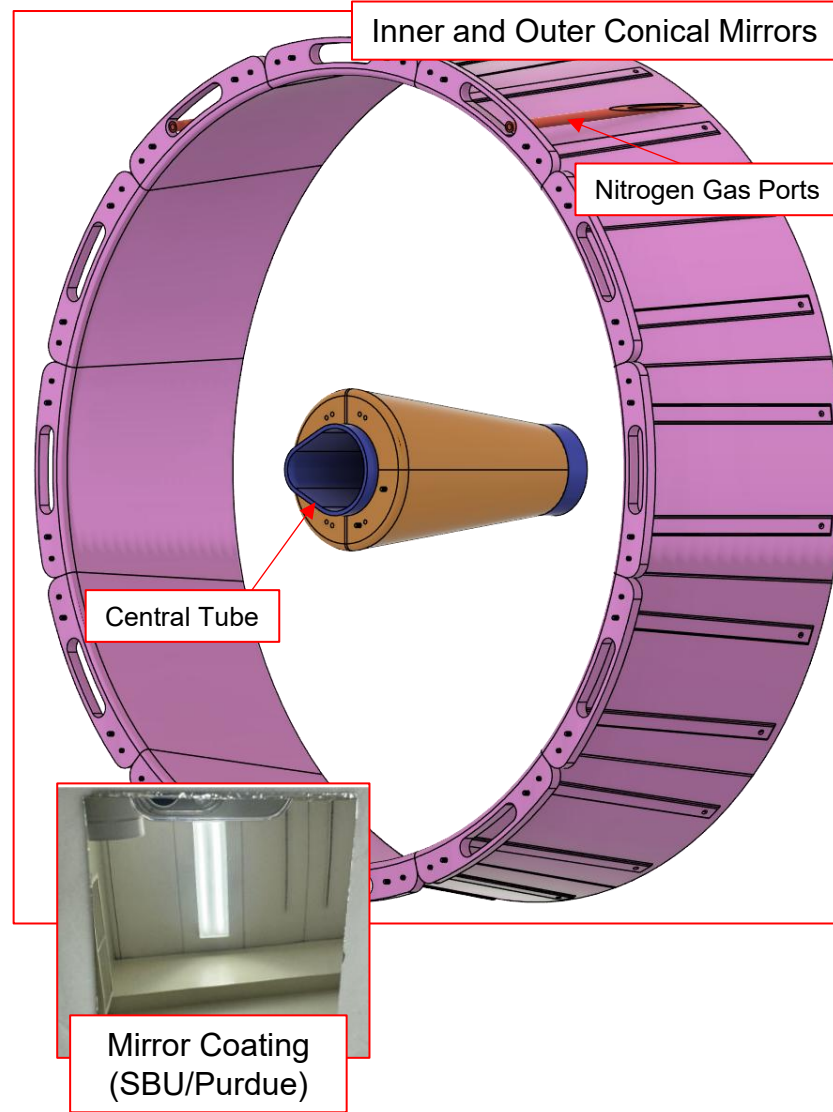

# Purdue Manufacturing

- Machining of the sensor plane is waiting on verification of the hole spacing as scanned from the original production
  - An inexpensive template is in-progress to verify hole pattern fitment on the vessel prior to the machining of the sensor plane
- Continued manufacturing and iteration of the large outer mirrors is ongoing. Minor design changes are being finalized.

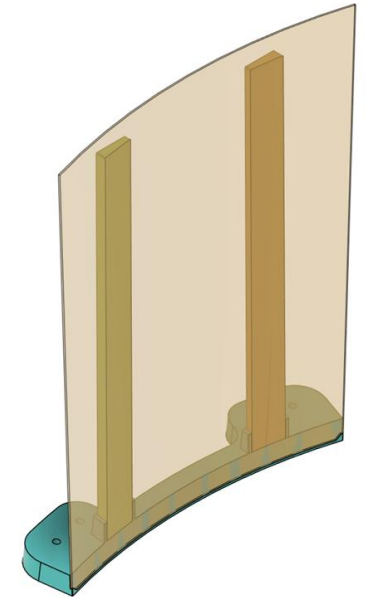
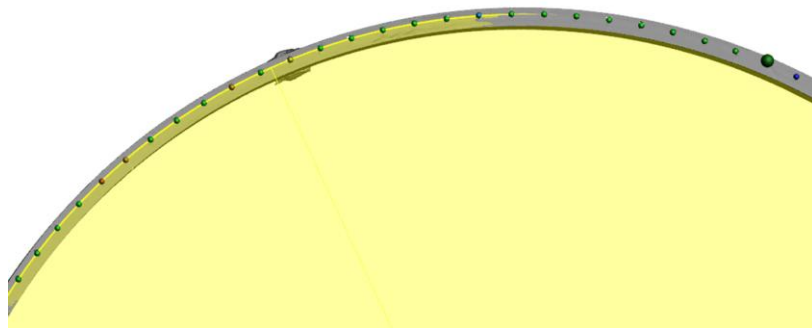
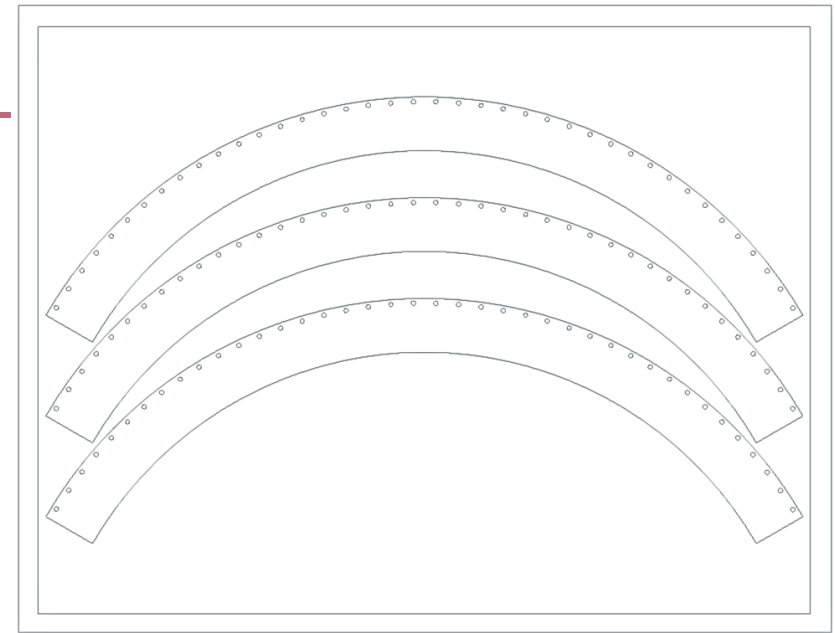

# Large Mirror QA

- Outer Mirrors are the new focus.
- Small samples have been coated and verified repeatedly:
  - Collab between SBU/Purdue/Project
  - Purdue produces the CF/Lexan
  - SBU coats the mirror and performs QA
- Integration into the large mirror test stand is ongoing
- PED request is fulfilled when we have two completed first articles

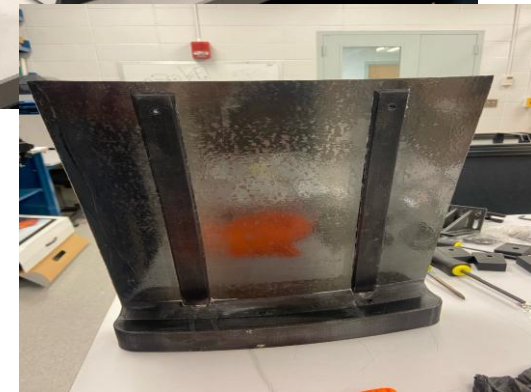

# Test Beam (CERN)

- pfRICH plans to receive test beam data to validate several key components. We will not have the full-scale prototype ready, so a mockup of existing hardware is being completed

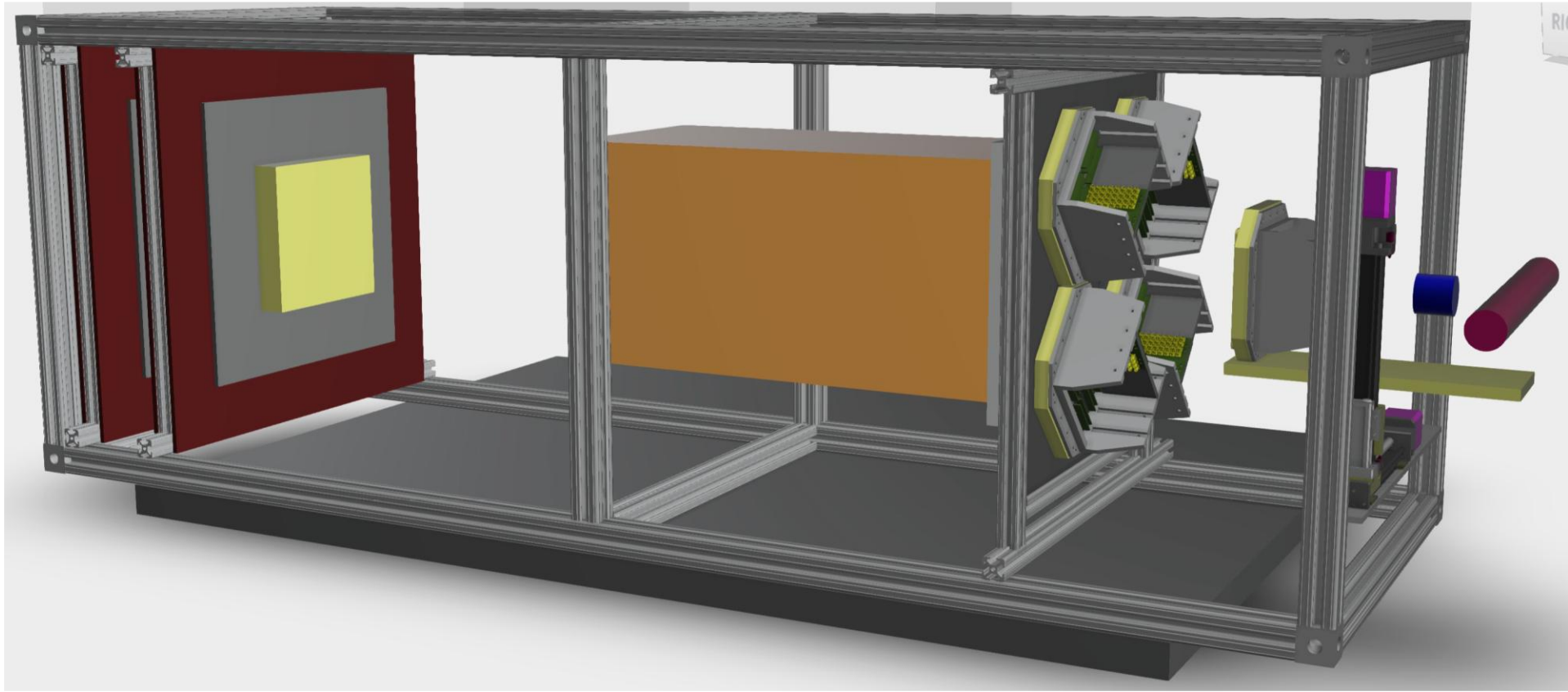

# HRPPD Updates

---

- New estimates seem to put the power consumption higher per HRPPD than originally thought
- Slides shown last week discuss **a possible** scheme where each HRPPD (with readouts) could have **~23W** per sensor instead of the original **~7W** per sensor
- Total pfRICH detector impacts: ~1500W vs ~500W
- These numbers **aren't confirmed yet**; I am reaching out to get more information.
- <https://indico.bnl.gov/event/32357/> (Power Estimates and Readout Scheme)

# Background Issues (TBD)

---

- We're still considering vessel grounding/shielding to protect sensors from noise and to aid in light-tightening the vessel
- Still a lingering concern about the beampipe bakeout effects on pfRICH componentry
  - Destructive testing of a small carbon fiber mirror sample has shown that it can withstand significant heat
  - The HRPPD has an indium seal which is only good for ~70C
  - FEA shown a few weeks ago shows MLI not likely a good fit for insulation; more sensitive to airflow rate
  - Unsure what design decisions flow from the forced air cooling
    - I've not seen any further details on the air cooling of the beam pipe other than the ANSYS sim
  - I haven't seen any updates to the beampipe temperature at various locations model.

---

# Question & Comments

---

# Backup

# HRPPD Progress (Background)



pfRICH

## Interconnect from S.Platform to Detector

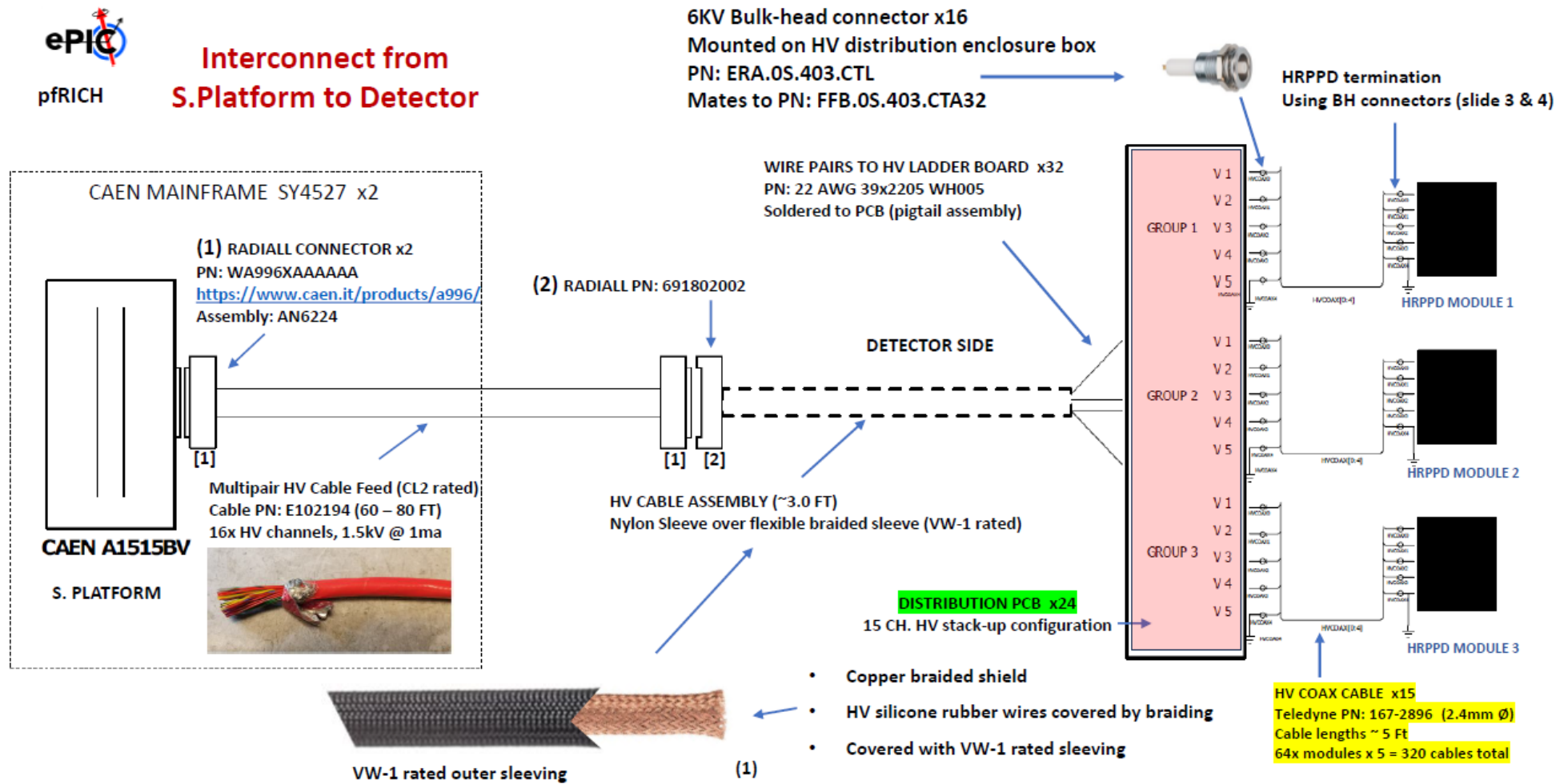

Tim Camarda for the ePIC project, BNL 2025

2