

ECT Model Update

Stefano Gramigna (sgramigna@roma2.infn.it) on behalf of the ePIC ECT working group:

C. Ammendola, R. Ammendola, M. Bondi, A. D'Angelo,

R. Di Salvo, A. Fantini, L. Lanza, S. J. Lee, G. Nobili, E. Sidoretti

April 27th, 2026 - I3 Meeting

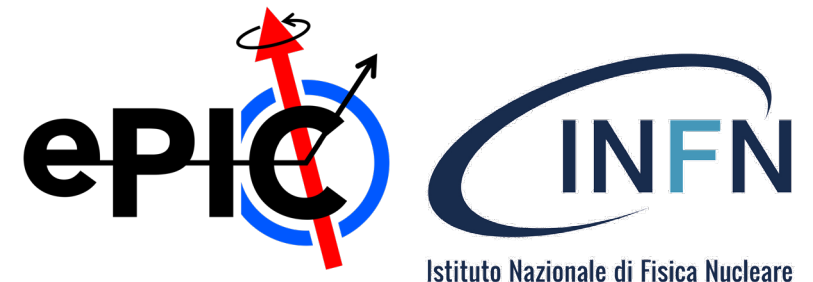

Overview

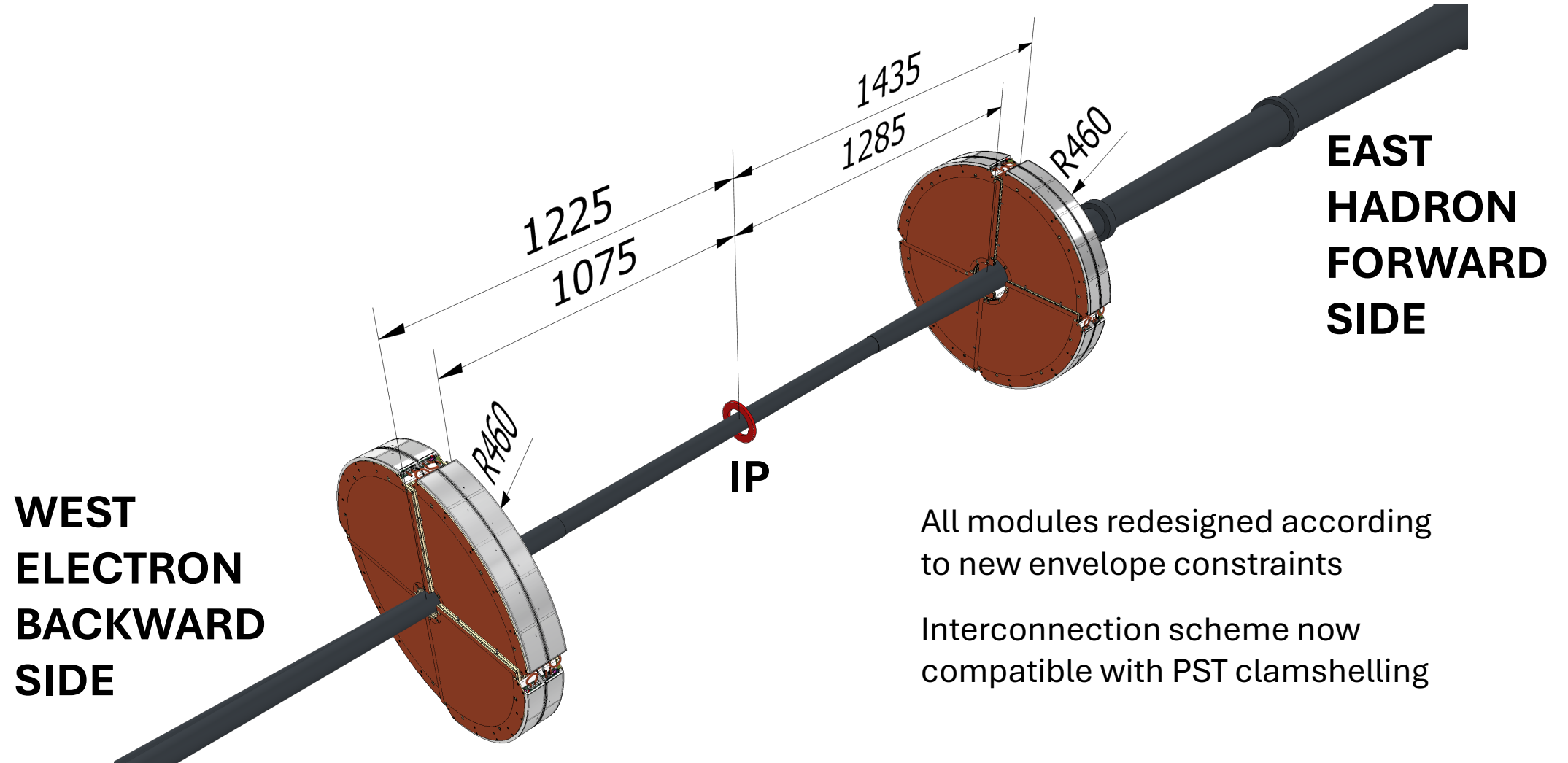
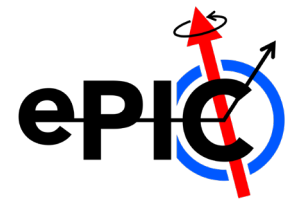

Interconnection

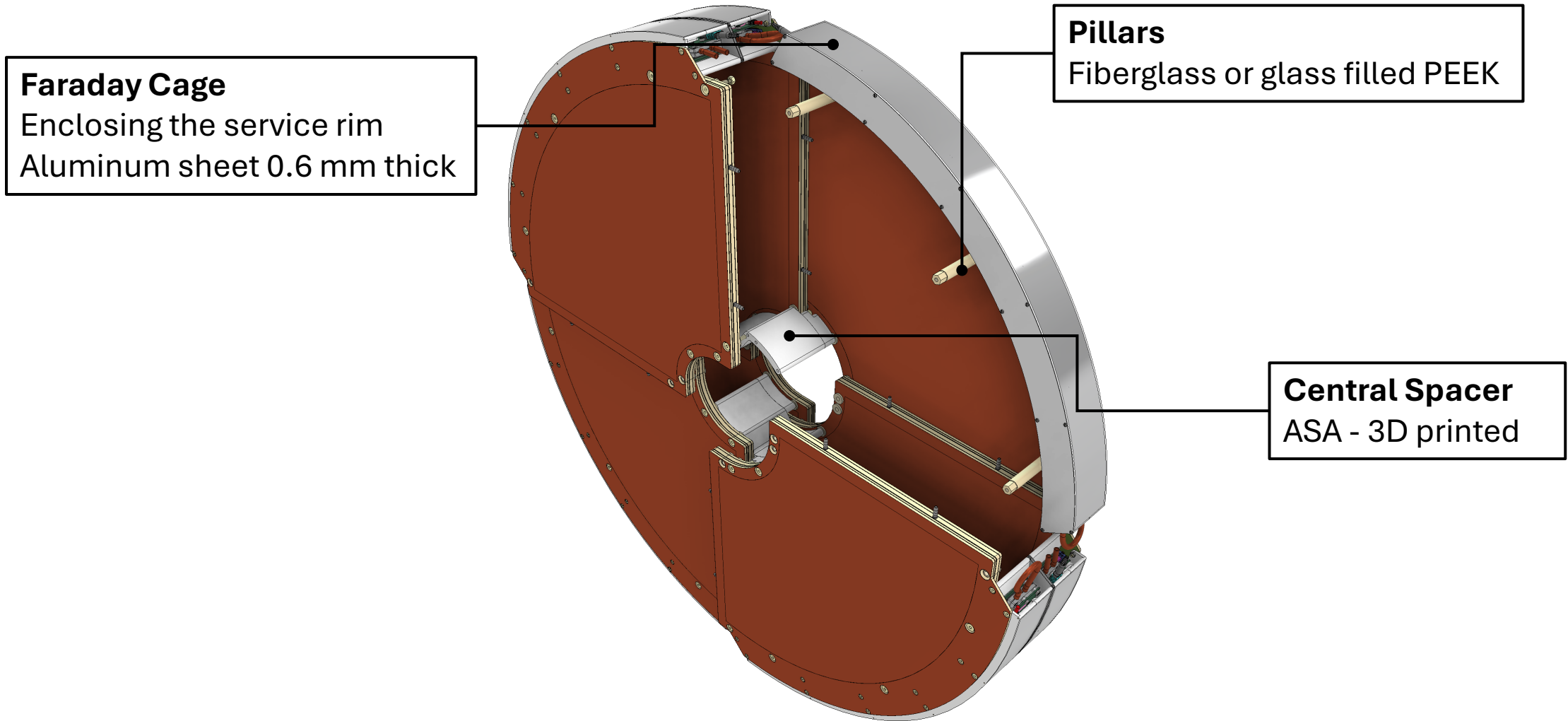

Module

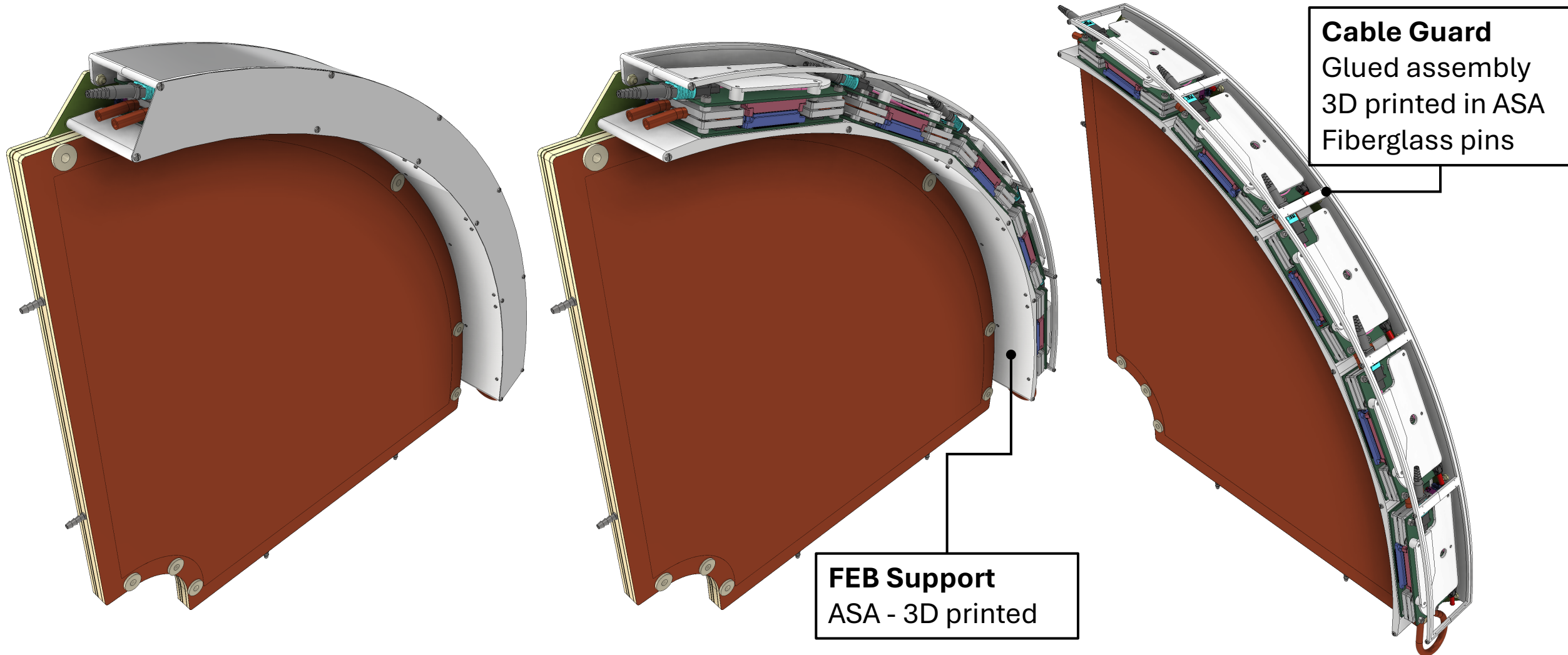

ECT Package Subassembly

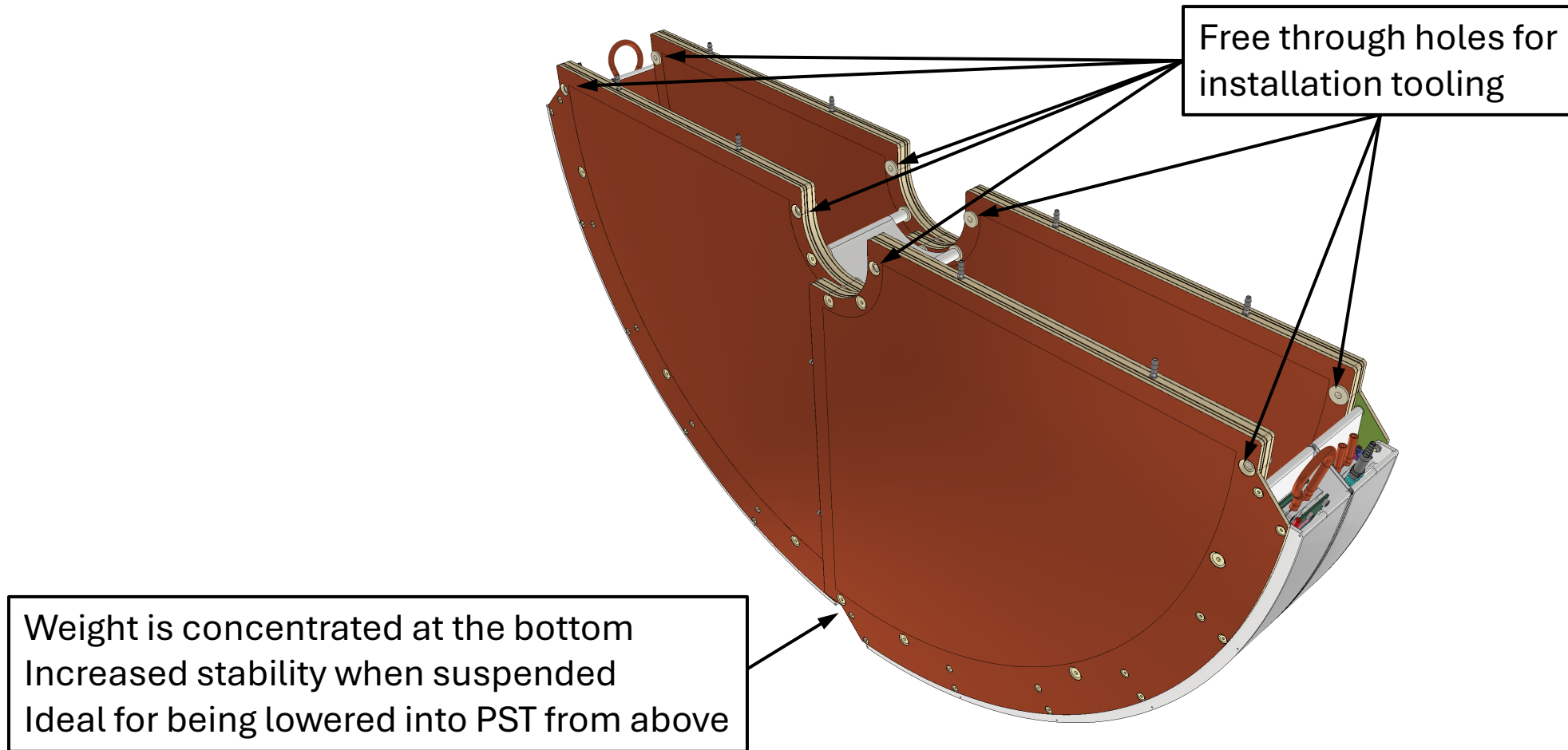

Front End Board Conceptual Design

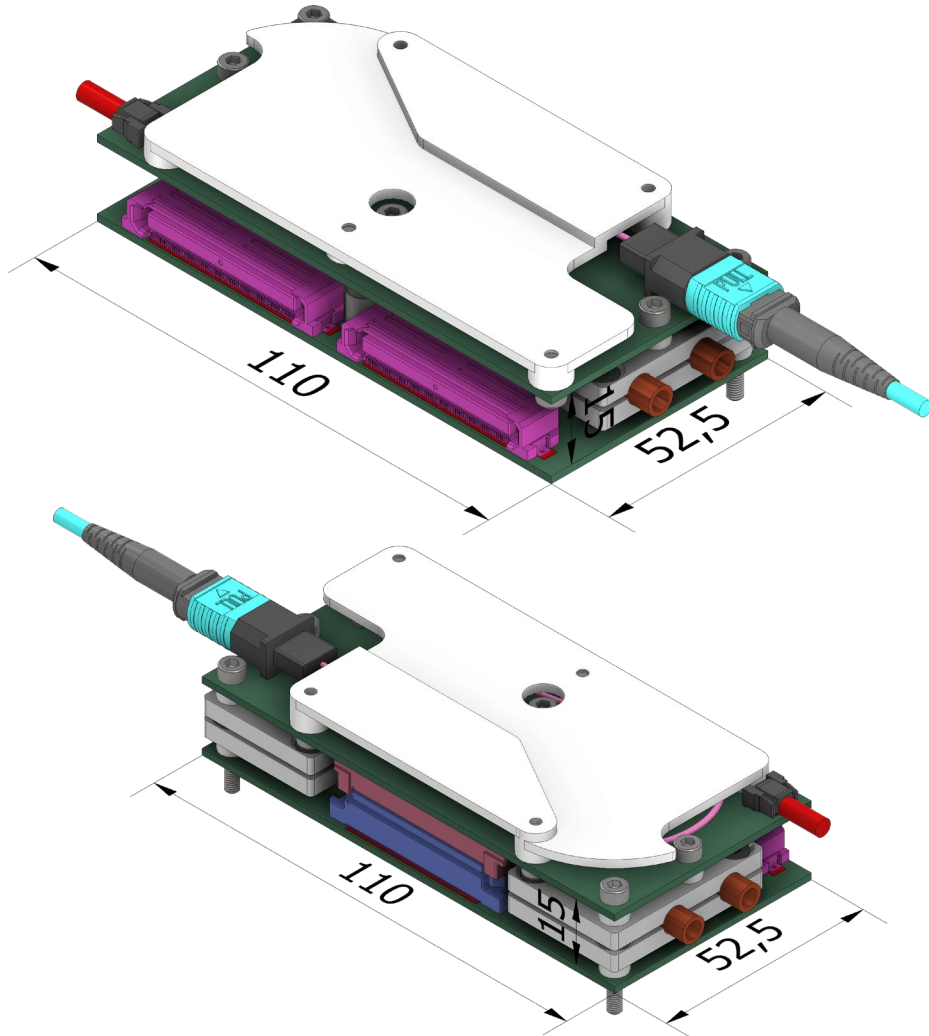
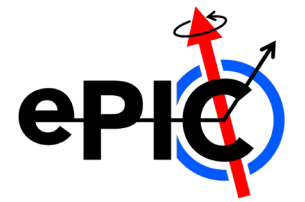

3D printed **pigtail guard (ASA)**

FE2 (COM/PWR)

1x vTRX+

1x lpGBT

2x DC/DC Conv.

2x LDO

1x HRS FX20-140P

1x MT-MPO Conn.

Aluminum heatsink

clamped on **copper pipe**

FE1 (DAQ)

4x SALSA ASICs

2x LDO

3x HRS FX20-140P

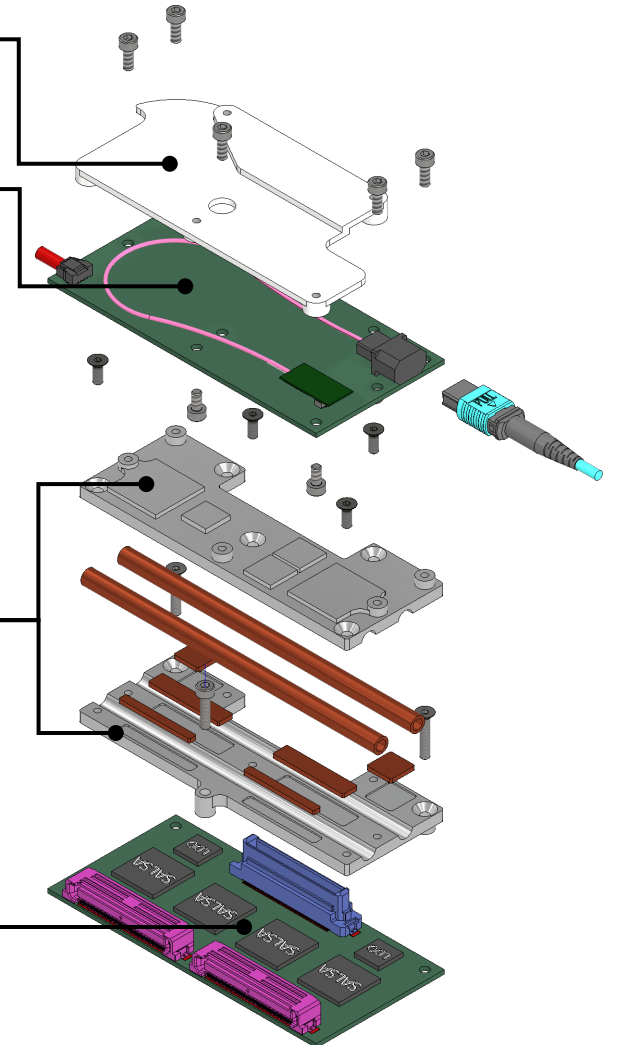

Heatsink

