

ePIC Collaboration Technical Coordinator Report

Silvia Dalla Torre



Electron-Ion Collider (EIC) Resource Review Board (RRB) Meeting
7th EIC RRB meeting, Tokyo, June 9th –10th, 2026

OUTLOOK

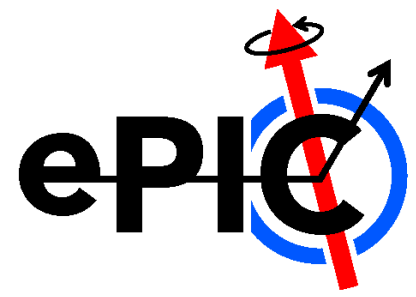

- The ePIC detector, a reminder of the key points
- Intense ePIC detector activity towards engineering the subsystems
- Deeper and deeper assessment to the detector performance
- Resources generated by the Collaboration engagement
- Summarizing

The Dual Nature of the ePIC Detector

ePIC is the Project Detector

Project mission for the ePIC detector

- ensure that all aspects related to the EIC project realization and completion are satisfied

Project support to the ePIC detector

- Administrative structure
- Engineer team
- Financial support
 - Past : mainly via R&D program
 - Present: mainly via PED (Project Engineering & Design)
 - After CD3: construction

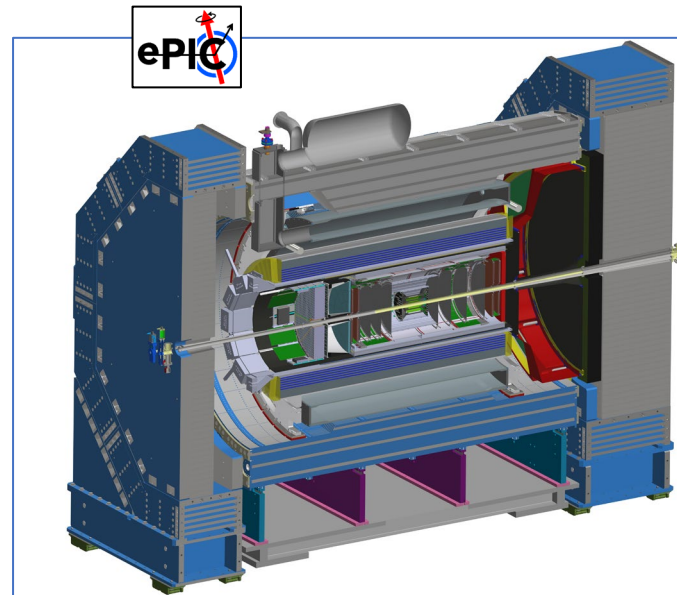

ePIC is the detector to which the ePIC Collaboration is dedicated

Collaboration mission for the ePIC detector

- optimize the physics reach of the detector
- manage the international Collaboration

Collaboration support to the ePIC detector

- Scientific workforce
 - For hardware, software and dedicated physics studies
- Financial support
 - Staff members from Academic Institutions and International Institutions
 - Past and present: international cofinancing R&D, engineering studies
 - International in-kind contributions to constructions

Beyond these specificities, **Project and Collaboration are synergistically cooperating** across the two missions towards the common goal: **a detector matching the overall EIC physics scope.**

The ePIC organization model for the detector

Detector Subsystem Collaboration, DSC (15 DSCs, in total) guided by a Leader (DSL) or two co-Leaders assisted by Technical Contacts (DSTC) and with autonomous internal organization

Overall Detector Consistency

is ensured by

- ePIC Technical Coordination
- Role of DSLs/DSTCs in the Project

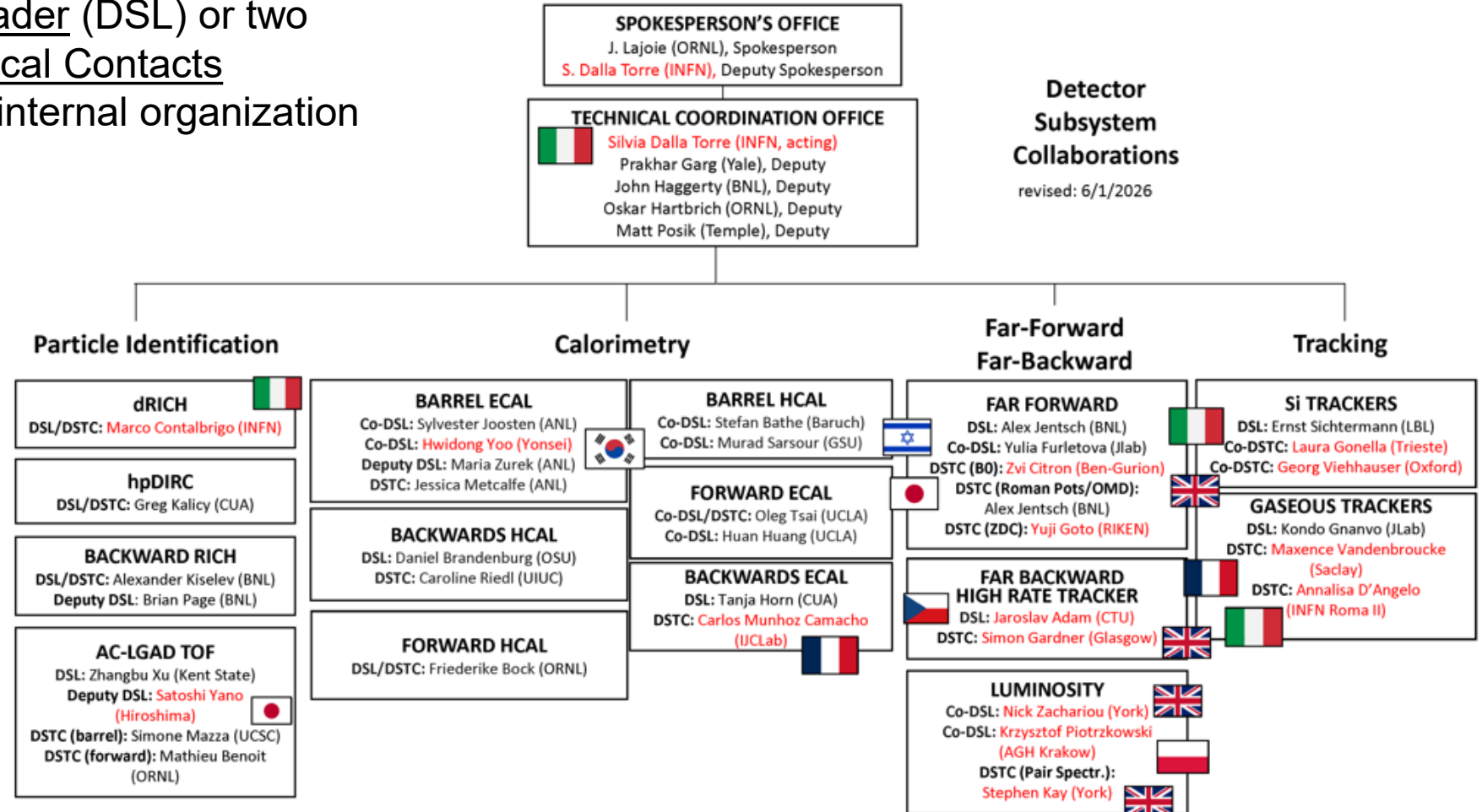

EIC Project and ePIC Collaboration integrated detector effort

ePIC Collaboration

EIC Project

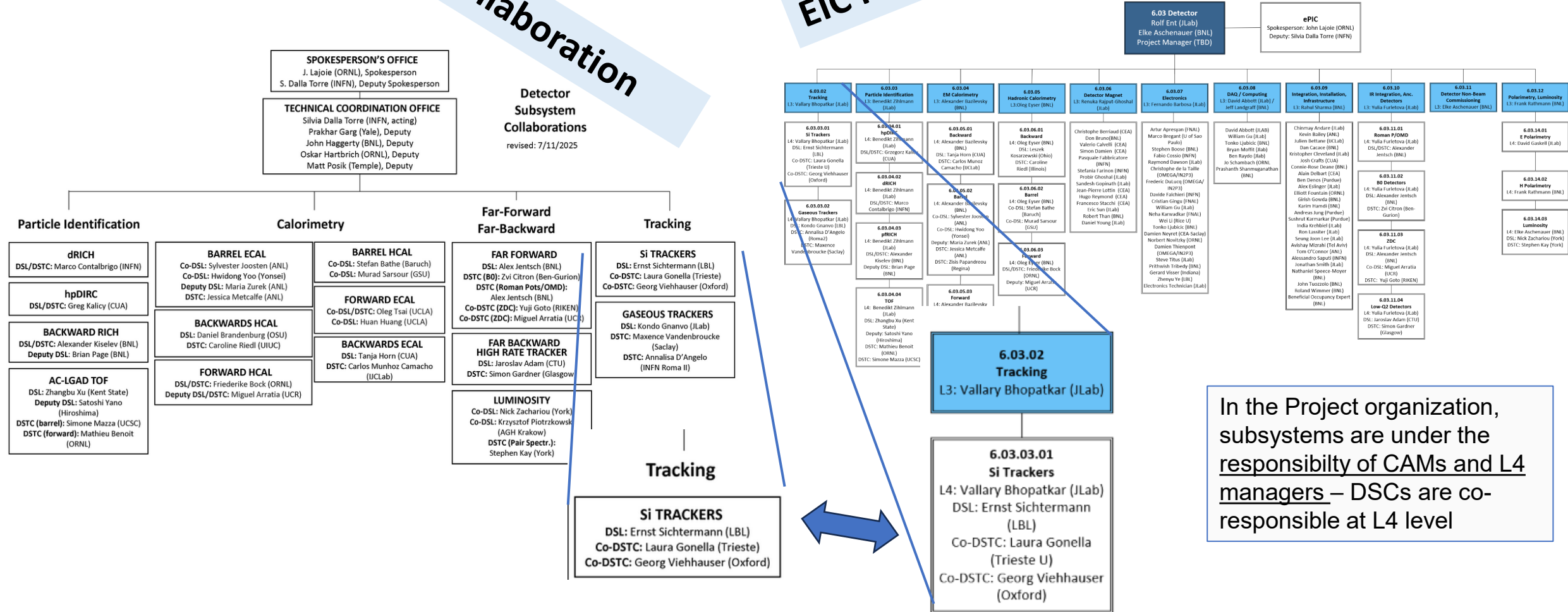

The ePIC Detector

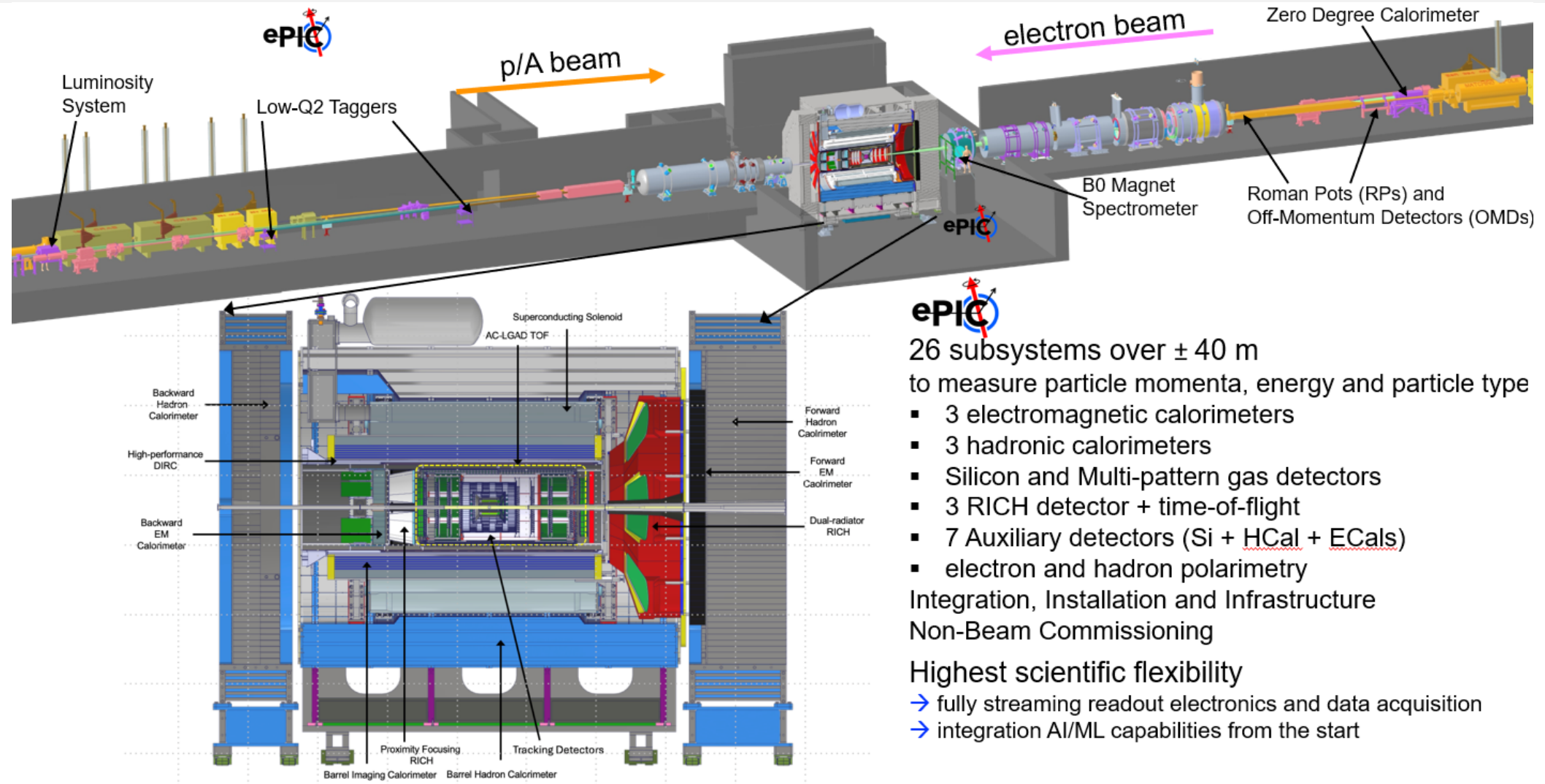

- ePIC**
- 26 subsystems over ± 40 m to measure particle momenta, energy and particle type
- 3 electromagnetic calorimeters
 - 3 hadronic calorimeters
 - Silicon and Multi-pattern gas detectors
 - 3 RICH detector + time-of-flight
 - 7 Auxiliary detectors (Si + HCal + ECal)
 - electron and hadron polarimetry
- Integration, Installation and Infrastructure
Non-Beam Commissioning
- Highest scientific flexibility
- fully streaming readout electronics and data acquisition
 - integration AI/ML capabilities from the start

OUTLOOK

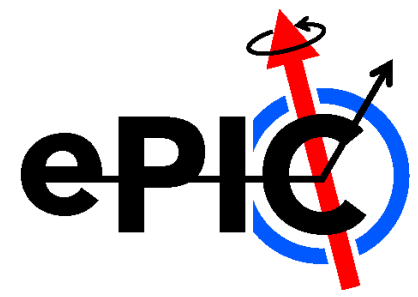

- The ePIC detector, a reminder of the key points
- Intense ePIC detector activity towards engineering the subsystems
- Deeper and deeper assessment to the detector performance
- Resources generated by the Collaboration engagement
- Summarizing

SENSORS for ePIC CALORIMETRY

arXiv > physics > arXiv:2503.14622

Physics > Instrumentation and Detectors

[Submitted on 18 Mar 2025]

Measurement of SiPM Dark Currents and Annealing Recovery for Fluences Expected in ePIC Calorimeters at the Electron-Ion Collider

Jiajun Huang, Sean Preins, Ryan Tsiao, Miquel Rodriguez, Barak Schmookler, Miquel Arratia

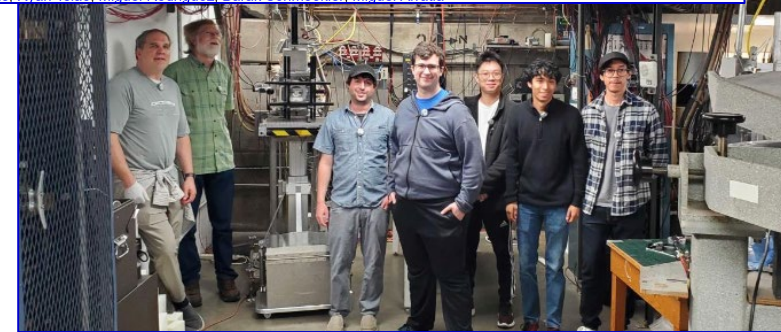

SiPM sensors for all Calorimeters

→ Irradiation campaigns for all SiPMs type foreseen in ePIC Colorimetry

Rad Dose

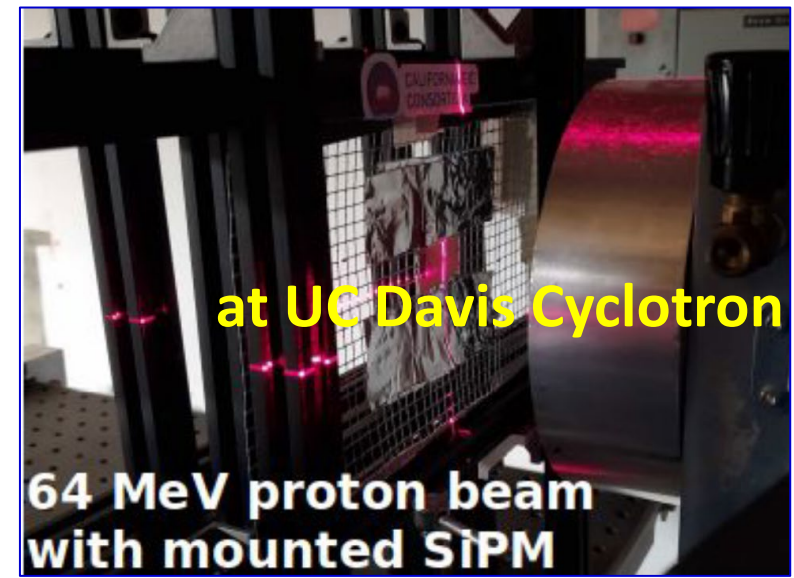
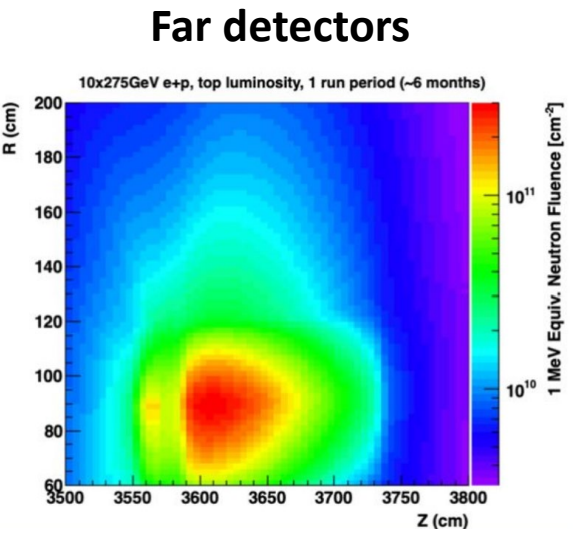
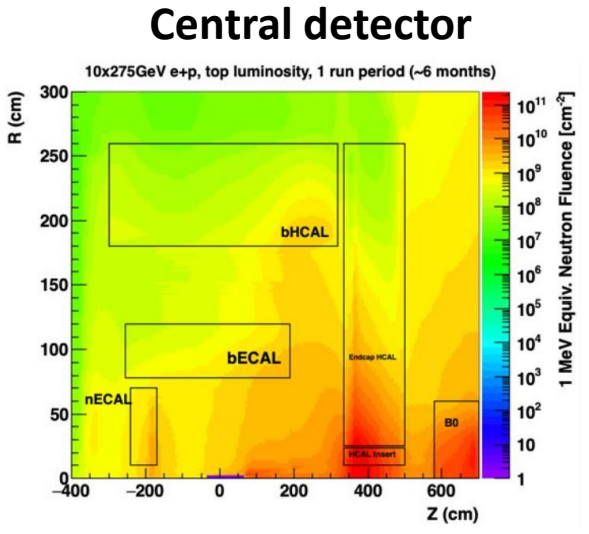
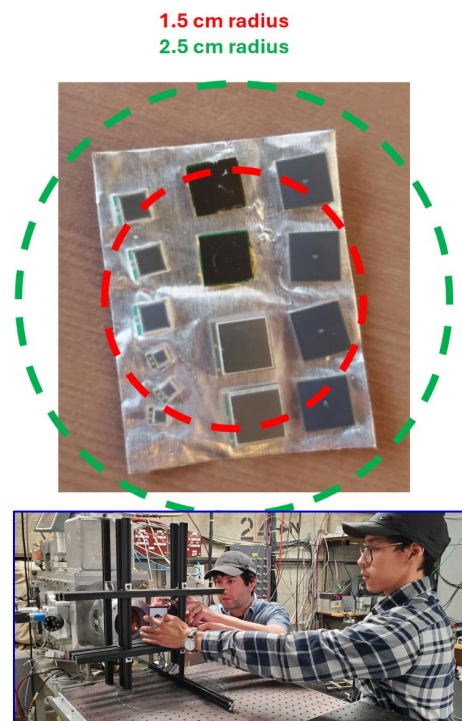

Models of SiPMs	$10^8 N_{p^+}$	$10^9 N_{p^+}$	$10^{10} N_{p^+}$	$10^{11} N_{p^+}$	$10^{12} N_{p^+}$	$10^{13} N_{p^+}$	ePIC Detector Usage
S14160 1315PS	1	3	3	3	3	2	nHCAL, pHCAL
S14160 3015PS	1	2	2	3	3	1	nEMCAL, bHCAL, pHCAL(Insert), ZDC
S14160 6015PS	1	1	1	2	2	1	nEMCAL, bEMCAL, pEMCAL
S14160 6050HS	2	4	4	4	4	2	bEMCAL, pEMCAL, pHCAL (Insert), ZDC
S13360 6050VE	2	2	2	2	2	0	bEMCAL

SiPM QUALITY CONTROL



On going QA for the LFHCAL SiPMs at Yale:

- CD-3A procurement shipments of Hamamatsu S14160-1315PS SiPMs
- 33k/month starting summer 2025, ending Spring, 2026 (320k total)

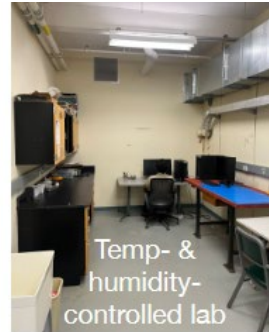

Temp- & humidity-controlled lab

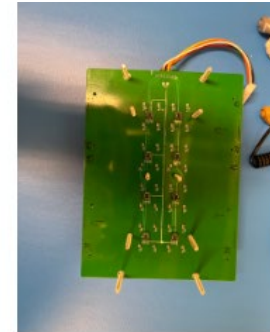

Grounded dark box/
Faraday cage

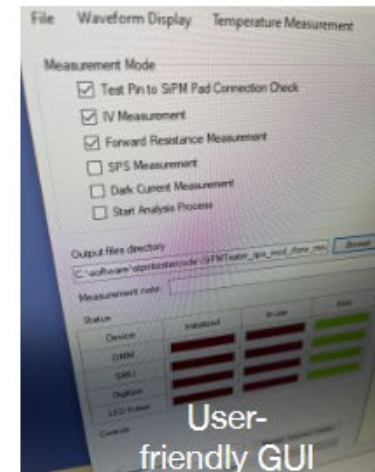

TestBeams and Lab Studies for TRACKING Subsystems

Testbeam at BASE (Berkley), May 2024

Testbeam Nov. 11-18, 2024 @PS-T10-CERN

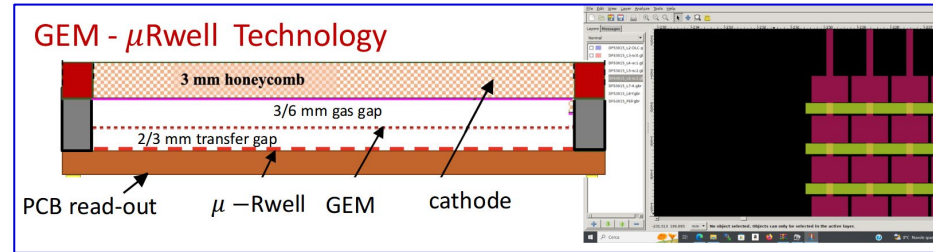

Testbeam Nov. 4-23, 2025 @SPS-H4-CERN

Si Trackers

MPGD Trackers

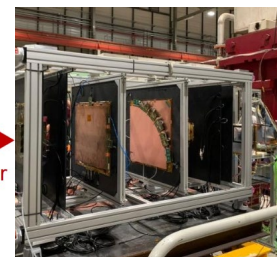
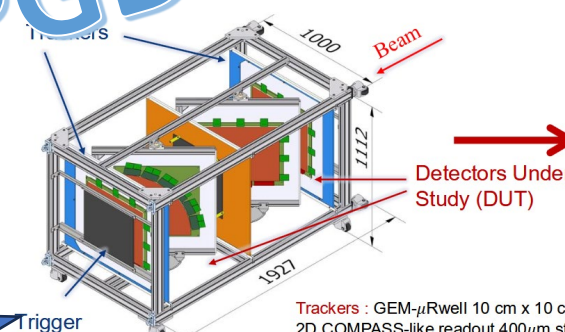
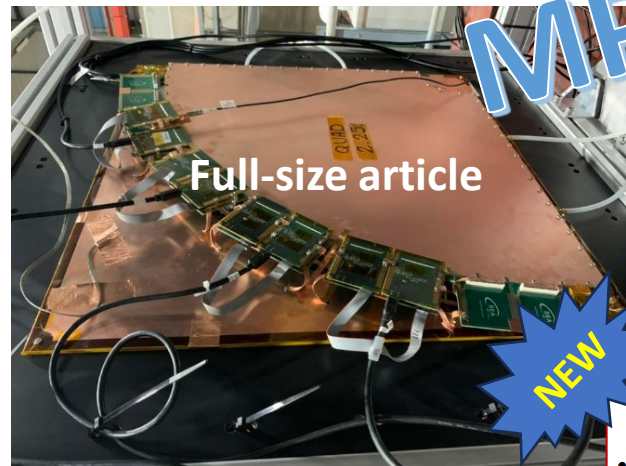

Further effort schedule in August 2026: gas mixture studies

Realistic quadrants Engineering Test Articles work as expected

- Position resolution is well below 150 μm , as required
- Detection efficiency > 95 %
- Time resolution under study but expected to be lower 20ns

TestBeams and Lab Studies for EM Calorimeters

Backward Ecal

test beams at DESY:

- Feb 17- Mar 2, 2025
- Mar 28 – April 7, 2025
- Dec 8-22, 2025



Backward EMCAL

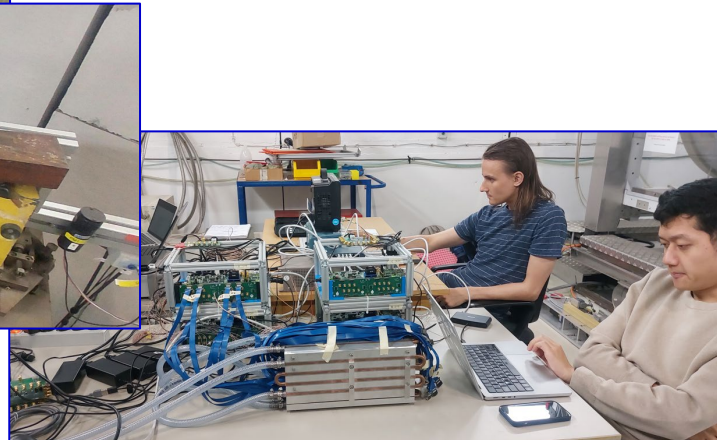

- ### Test article improvements:
- Improve crystal SiPM mounting for poor light coupling
 - Better SiPM power supply
 - Improved grounding

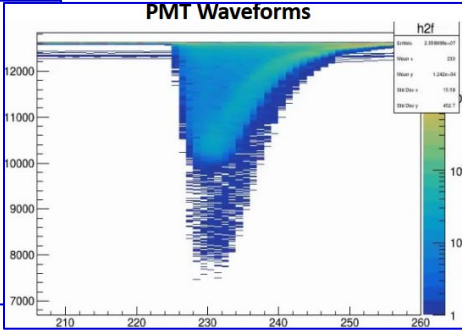

Read-out using discrete elements

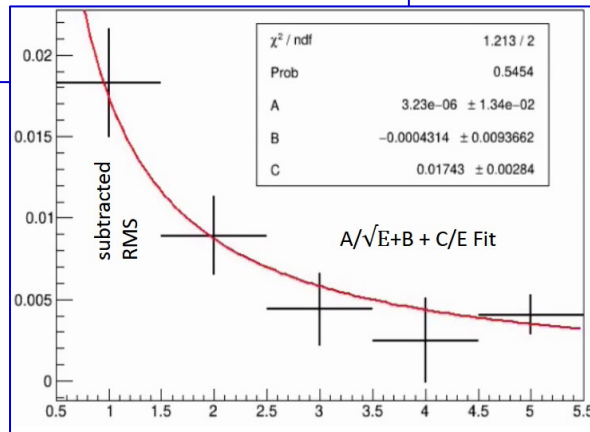

SiPMs vs MAPMTs

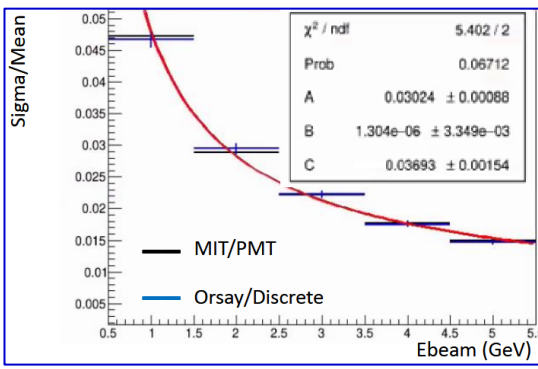

Read-out using FEE ASIC

- H2GCROC chip

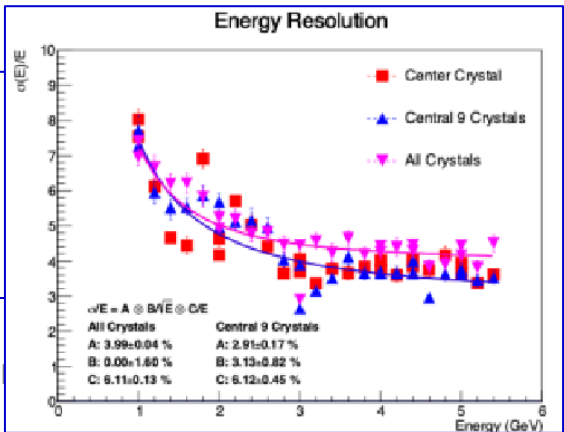

TestBeams and Lab Studies for EM Calorimeters

beam test in Aug 2024 at CERN PS T10

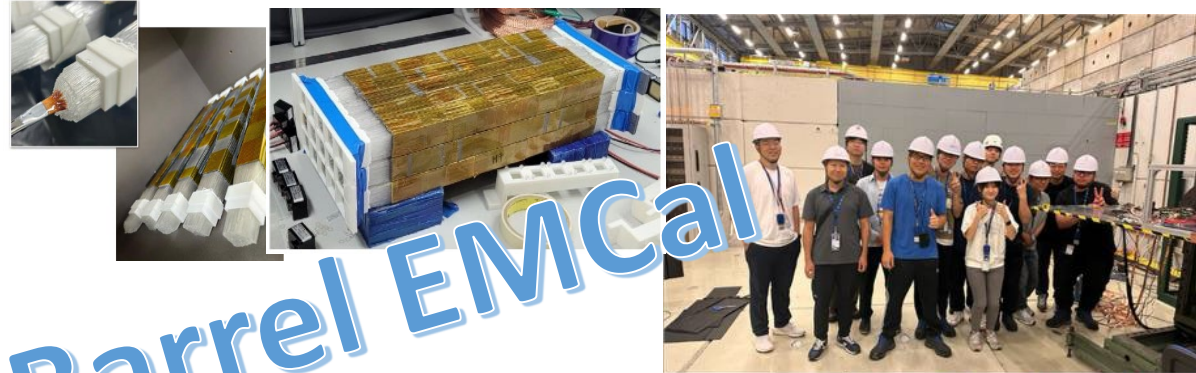

Barrel EMCal



beam test in Mar 2025 at KEK PF-AR

AstroPix data taking between Pb/SciFi layers

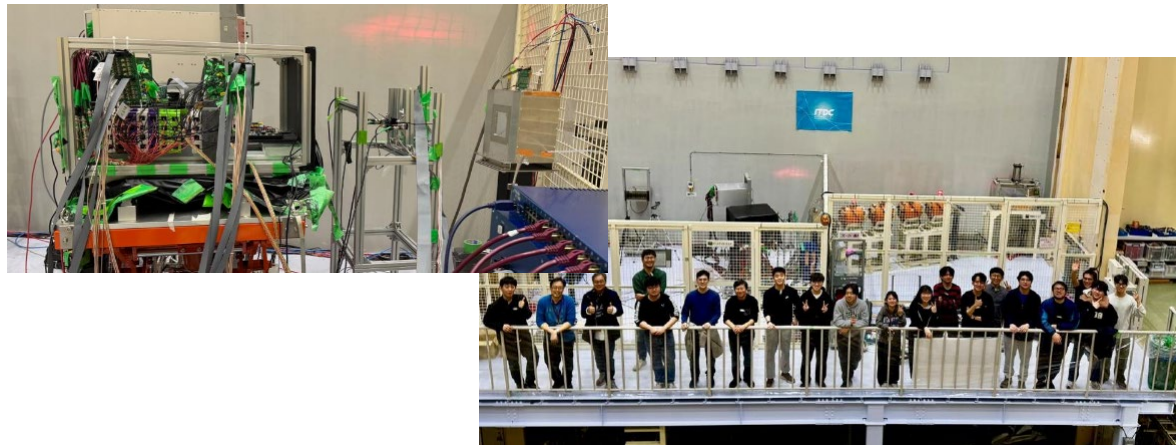

EIC RRB meeting, June 9-10, 2026



April-May 2026: Extended parasitic testbeam at Jlab Hall D

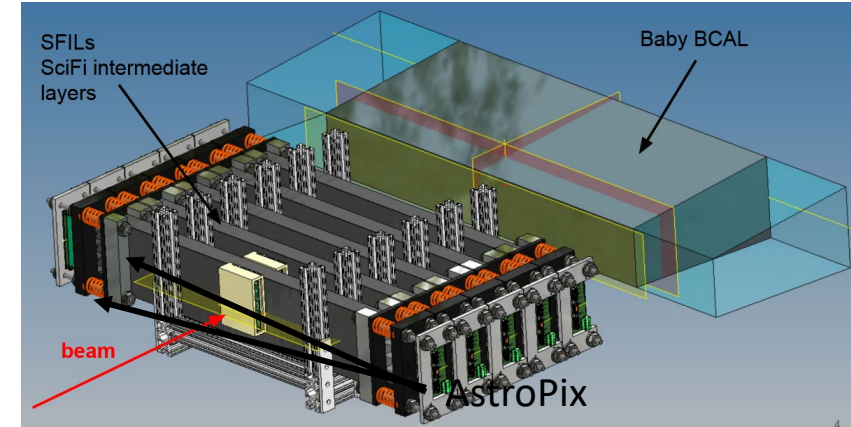
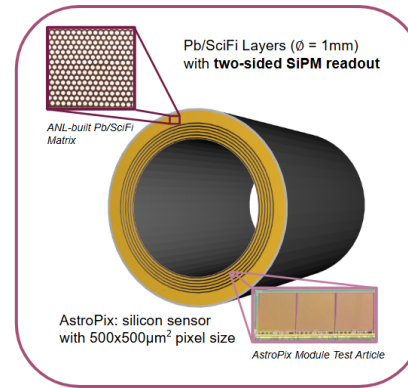

Beam direction

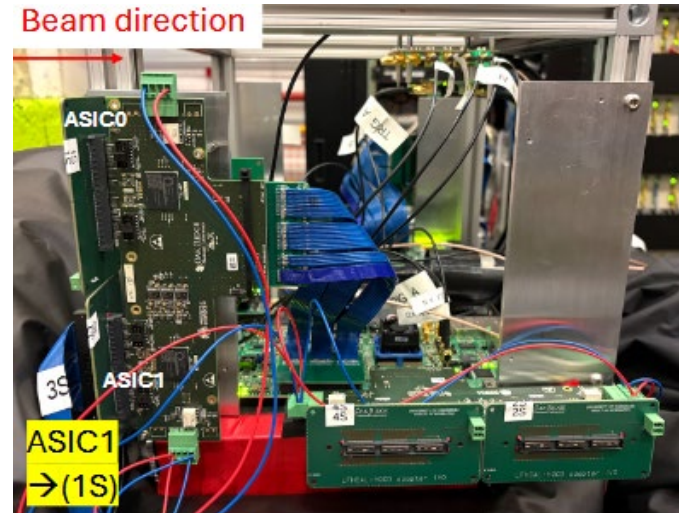

NEXT coming:
Testbeam at
CERN PS :
8/28-9/3, 2026

TestBeams and Lab Studies for Hadronic Calorimeters

Forward Hcal: INNOVATIVE ORIGINAL DESIGN : "SiPM on tile"

- inspired by CALICE developments adopted by ePIC

SiPM on tile

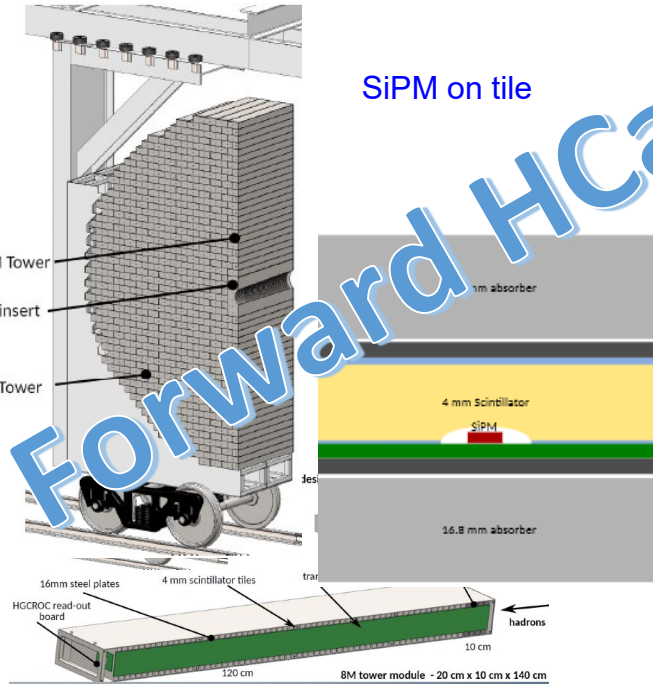

Forward HCal

Sept/Oct 2024:
First module at test beam



2025:
Test beam in November

2026:
Test beam with an enlarged sample of 8 modules

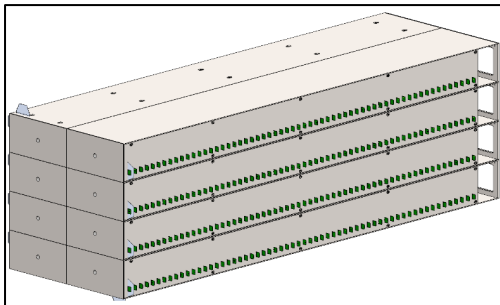

NEW



Same technology :

- Zero Degree Calorimeter

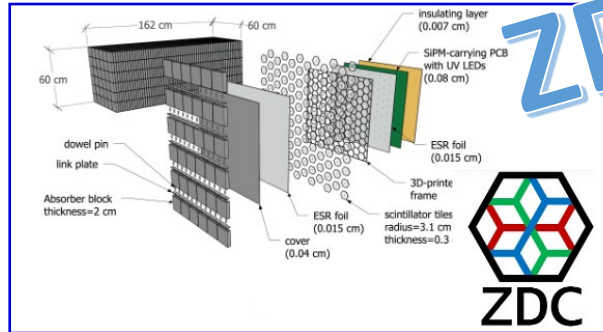
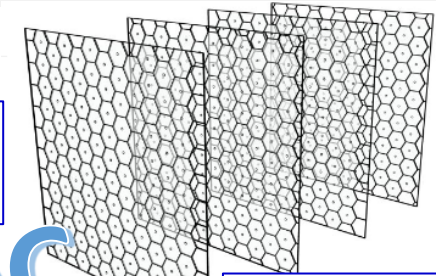

ZDC module tested at STAR in 2024



2024-2025



2025



2025

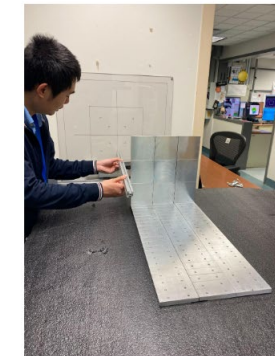

TestBeams and Lab Studies for PID Subsystems

BaBar fused silica bars infrastructure for bar disassembling and testing

- 120 short bars already obtained by disassembling
 - 35 of them fully tested:
 - 32 without defects;
 - 3 with limited damages at the extreme: to be used for the shorter lightguides between the sensor bars and the expansion elements
- 100% reusable



Fused silica bars, QC

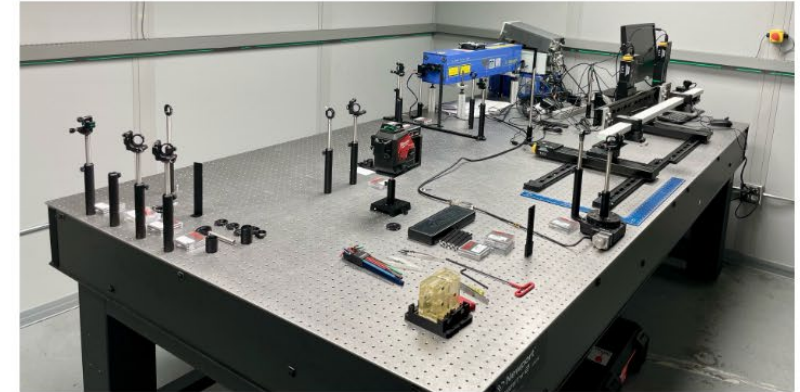

Measurement with 442 nm laser

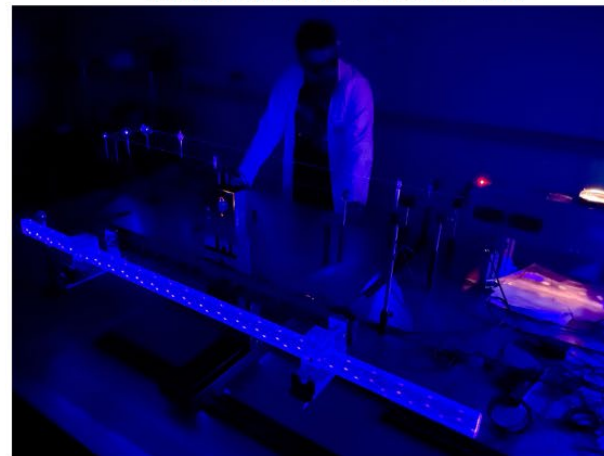

BaBar bars disassembling successfully progressing!

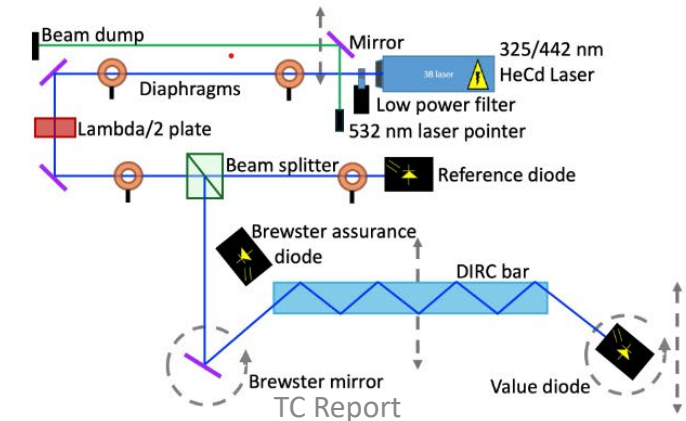

TestBeams and Lab Studies for PID Subsystems

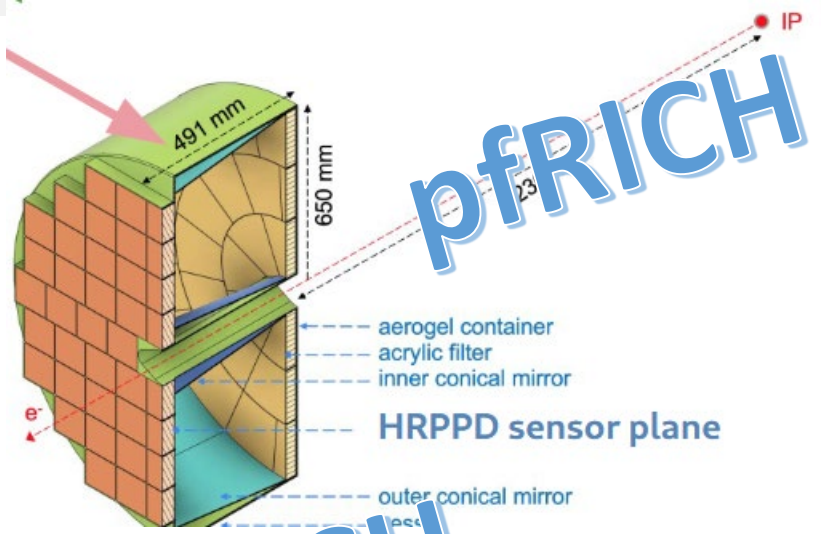

pfRICH

- aerogel container
- acrylic filter
- inner conical mirror
- HRPPD sensor plane
- outer conical mirror

HRPPD characterization

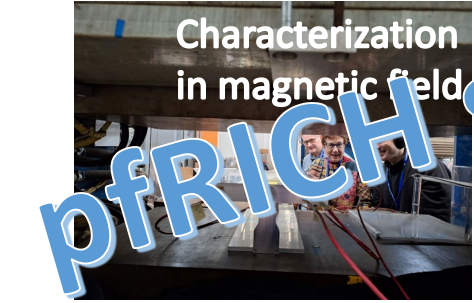
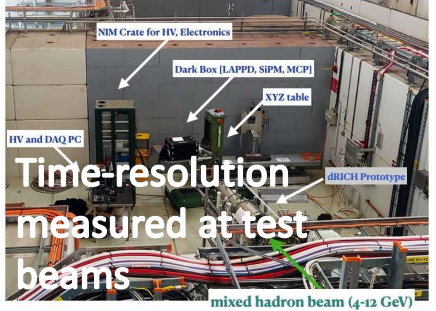

HRPPD accelerated ageing studied, 2025 campaign

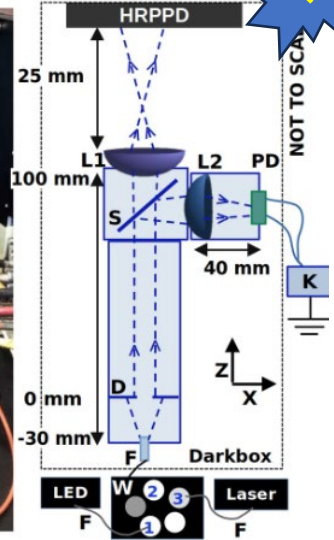
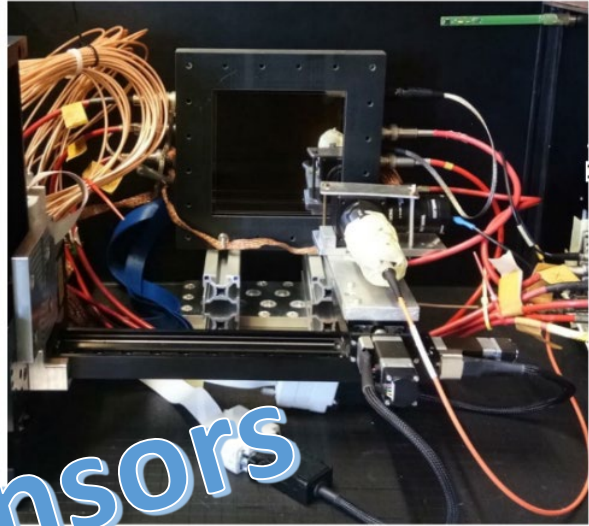

NEW

pfRICH test articles

NEW

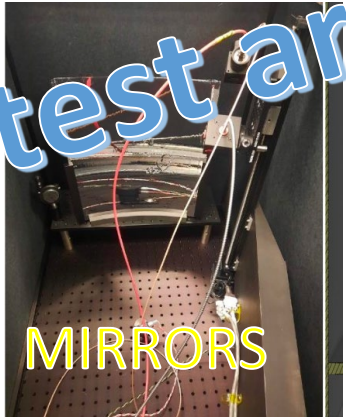

pfRICH sensors

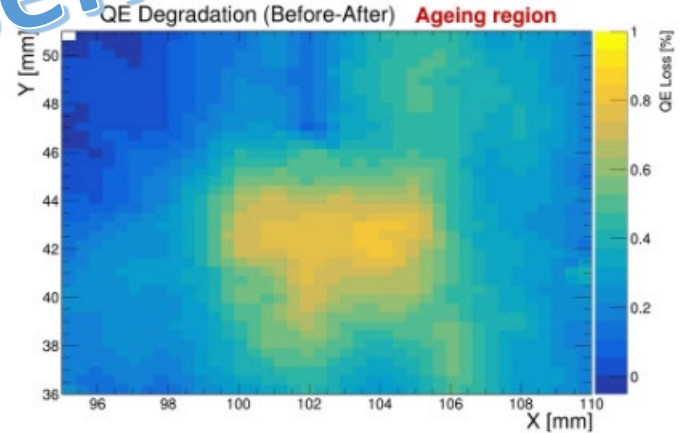

PRELIMINARY:
After ~10 EIC y illumination,
 Δ QE 0.8%, gain decrease ~ 20 %

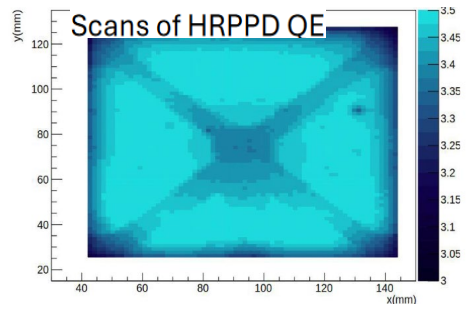

accelerated ageing studied, 2026 campaign in preparation

TestBeams and Lab Studies for PID Subsystems

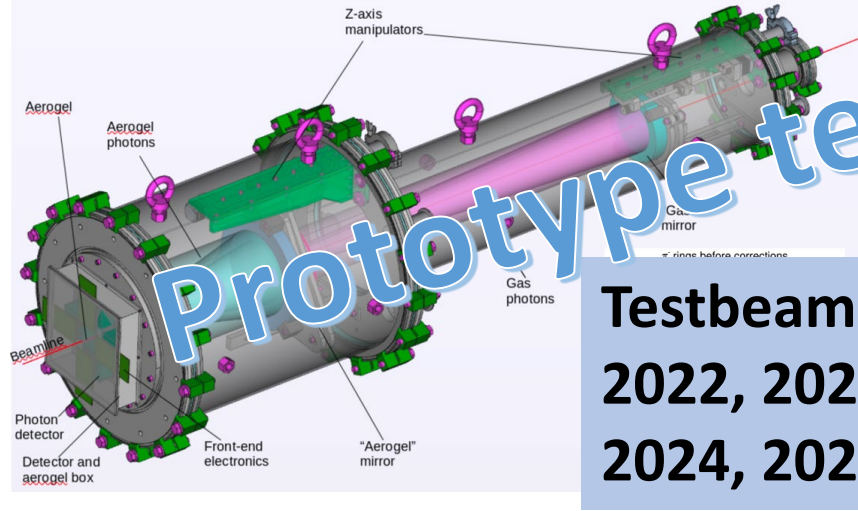
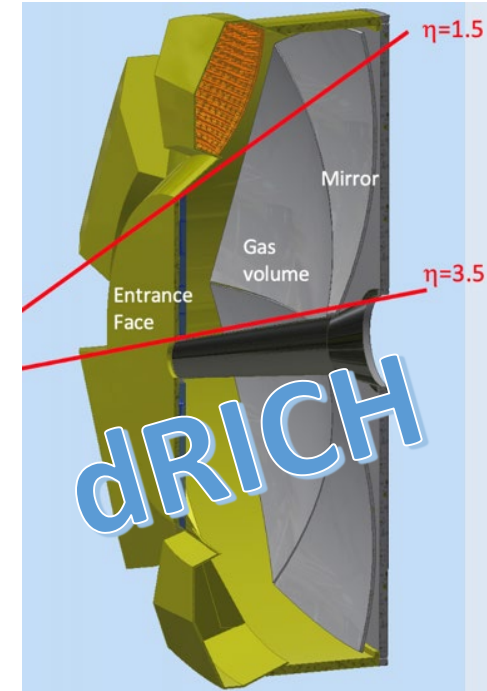

**Testbeams:
2022, 2023,
2024, 2025**

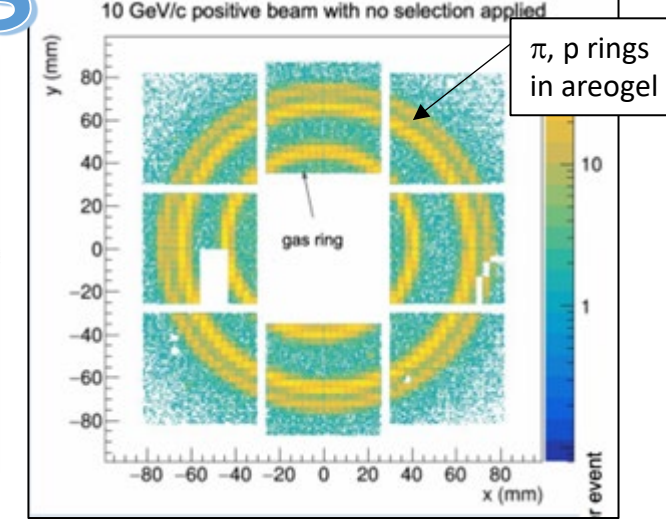
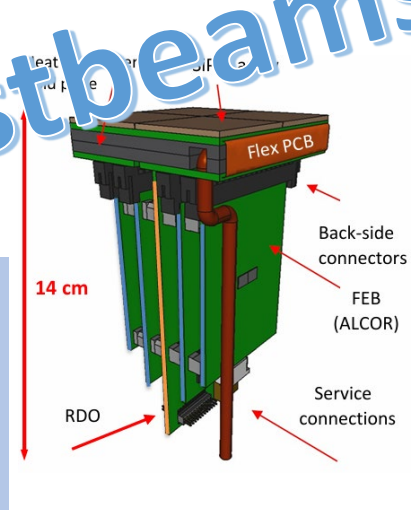

Engineered photon detector unit already used in 2024 and 2025 test beams with advanced version of the FEE ASIC.

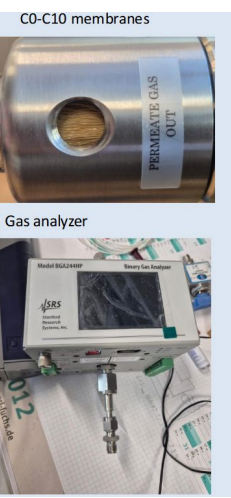

Gas system with gas recovery for 2026 test beams (May and June)

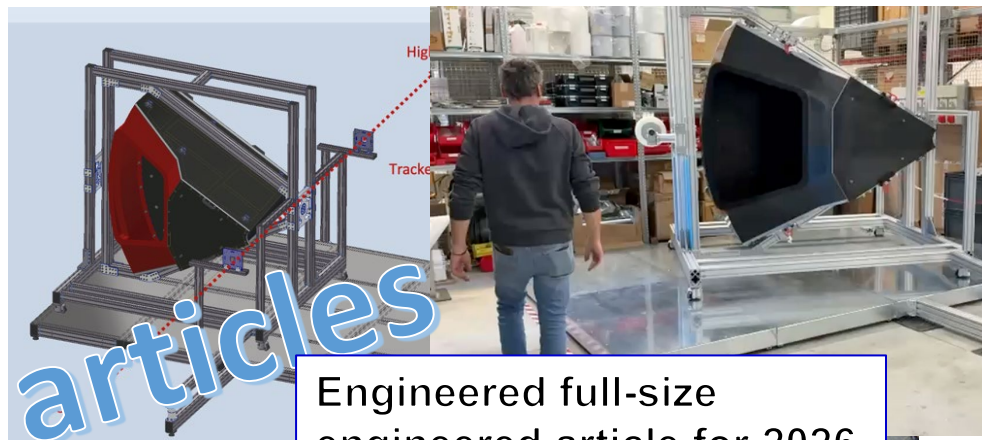
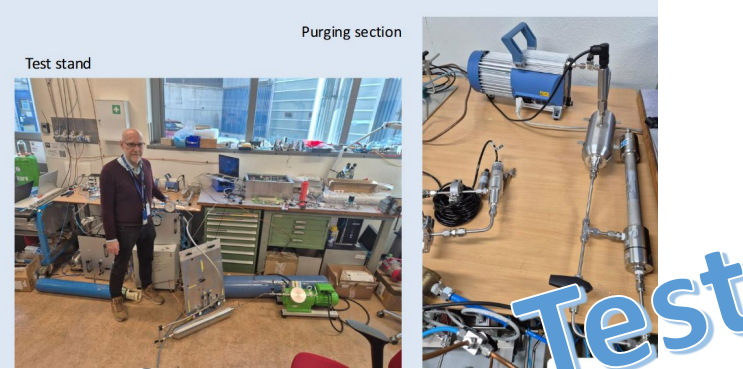

Engineered full-size engineered article for 2026 test beams (May and June)

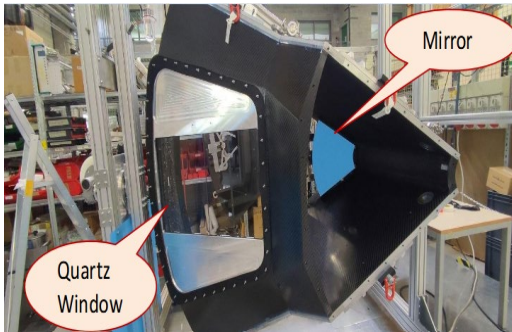

AC-LGAD TestBeams for PID and Far Detectors

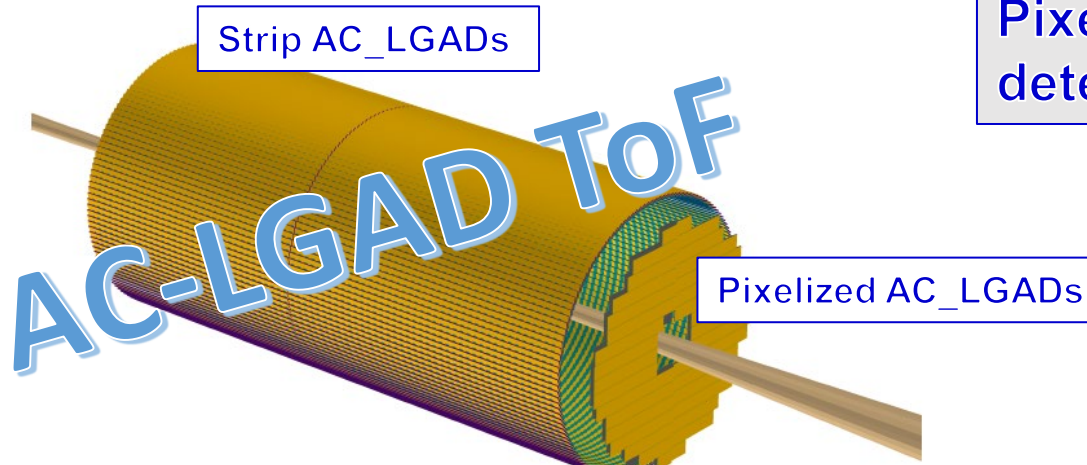

Pixelized AC-LGAD are also the trackers in far forward detectors : B0, OMDs. RPs

Pixelized and strip AC-LGAD parameters explored in a testbeam at FNAL (NIMA 1017 (2025) 170224)

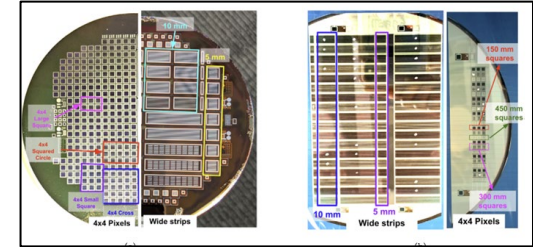

New Module-Size AC-LGAD Sensors (2nd HPK Production)

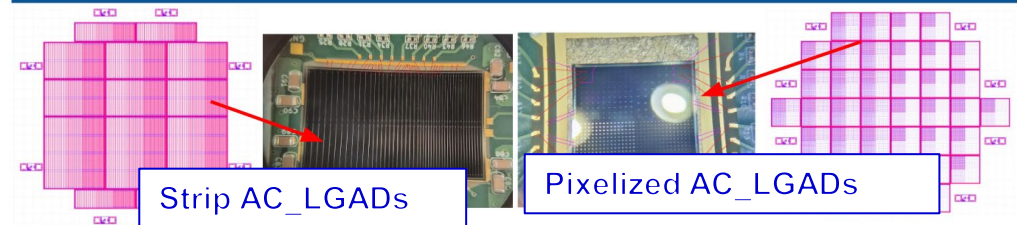

2025 testbeams:

- At Jlab, parasitic opportunities in Hall D
- At Desy

2026 testbeams:

- At KEK-PS in February 2026
- At RARiS, Sendai, Japan in March
- testbeam at CERN SPS, July 22-27 parasitic
 - GOAL: EICROC0 + pixel sensor integration
- At KEK-PS, Fall
 - GOAL: FCFD + strip sensor integration



Efficiency
>98%

Spatial resolutions
W15 (30um): $33.42 \pm 0.10 \mu\text{m}$
W13 (30um): $31.32 \pm 0.06 \mu\text{m}$

Time resolutions
W15 (30um): $63 \pm 8 \text{ ps}$
W13 (30um): $62 \pm 5 \text{ ps}$

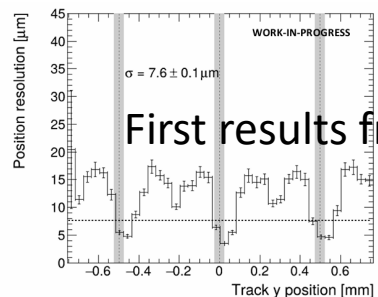

First results from Desy testbeam

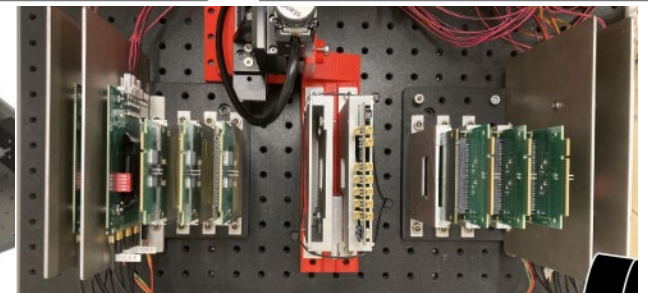
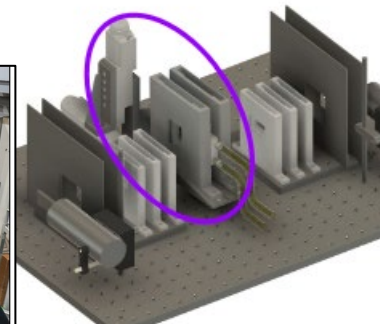
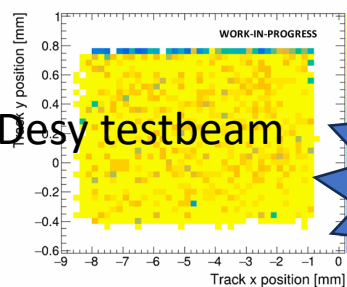

TC Report

LOW Q² TAGGERS, tracking

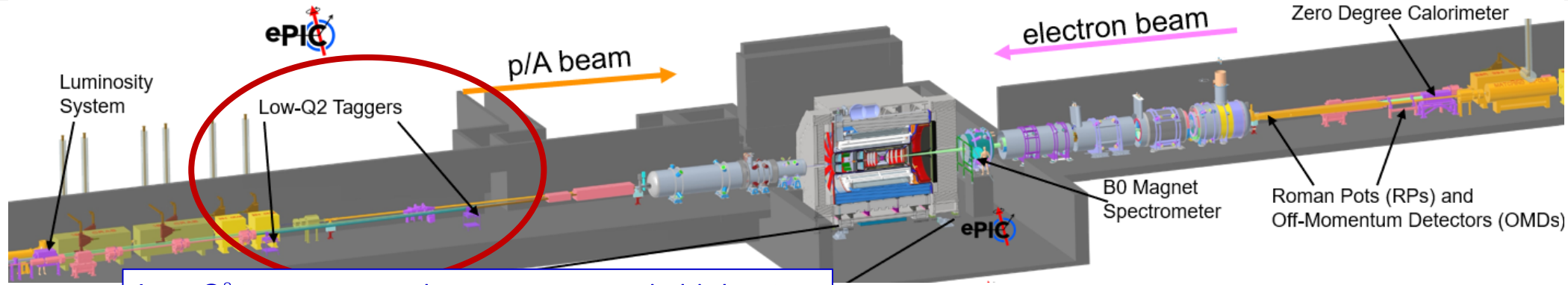

Low Q² taggers experience an extremely high rate
 → Use TIMEPIX4 as Tracker FEE ASICs

TIMEPIX4 studied in a testbeam at MAMI (Mainz) in February 2025

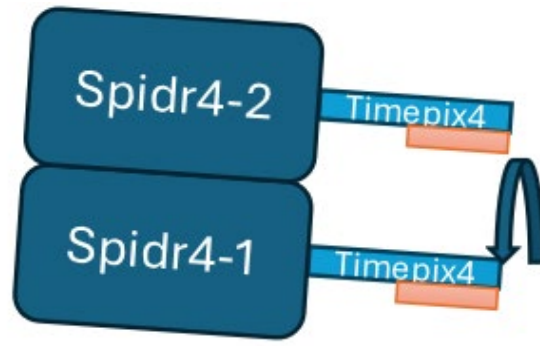
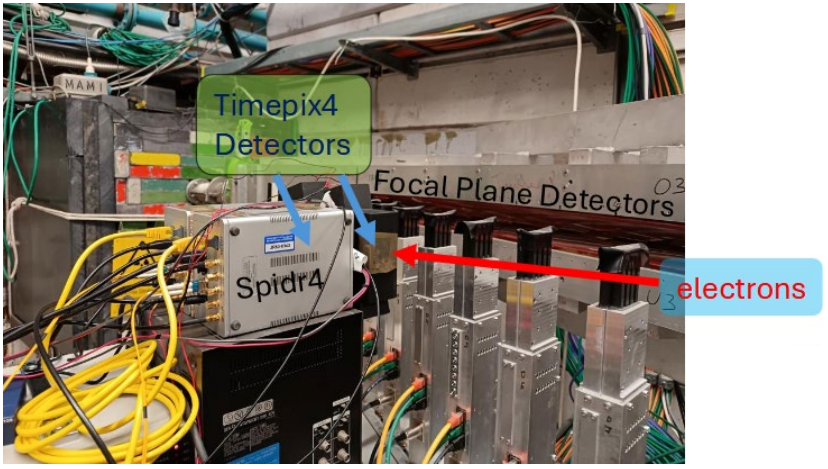

Cluster Shape Studies (Tilt)

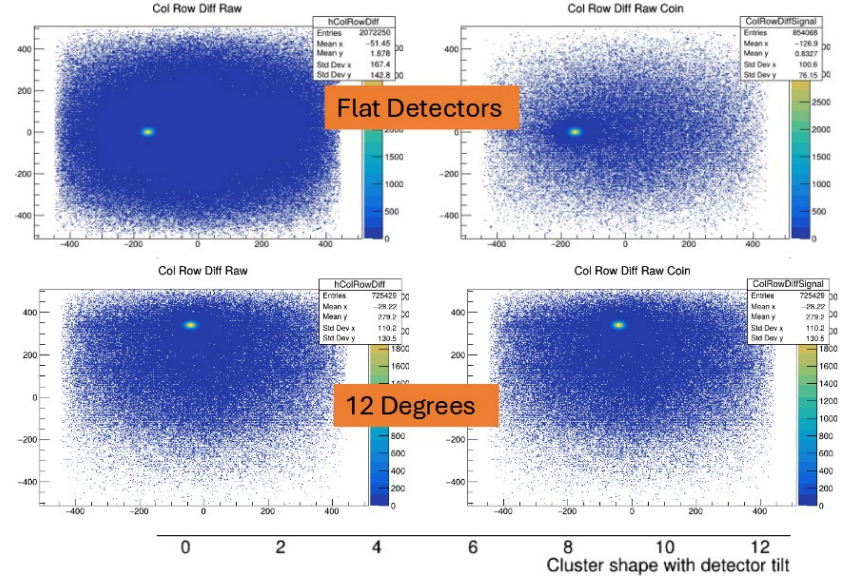

Front-End ASIC progress

FEE ASICs: a key role in subsystem as counterparts completing the sensors

5 novel FEE ASICs under development for ePIC, all successfully progressing as monitored by an extended internal review process



Strip AC-LGAD (barrel TOF)

- FCFD1.1 already used in testbeams with the strip sensor
- 32 ch.s architecture recommended in May 2026
- FCFD 32 ch.s finalized by 2027-28

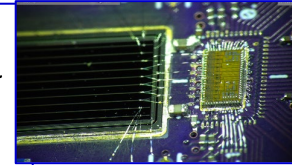

CALOROC – the FEE ASIC of ePIC calorimetry reading SiPMs

- H2GCROC used in testbeams (LFHCAL, EEEMC, BIC)
- 36 ch.s architecture recommended in September 2025
- CALOROC 2 final version expected by 2027

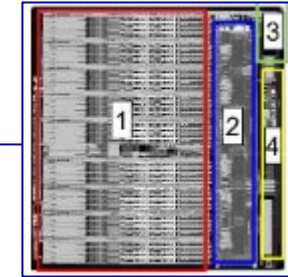

May 2026

- 20 May Internal Review - FCFD
- 13 May Internal Review - CALOROC
- 06 May Internal Review - SALSA

MPGDs

- SALSA 64 ch.s expected by 2027-28



April 2026

- 22 Apr Internal Review - ALCOR
- 01 Apr Internal Review - EICROC

dRICH SiPM (Cherenkov imaging application)

- ALCOR 32 ch.s already used in testbeam; ALCOR 64 ch.s available in 2027

Pixelized AC-LGAD (forward TOF, RP, OMD, B0)

- EICROC0 to be used in 2026 testbeam;
- EICROC(32 x 32 ch.s) expected in 2027

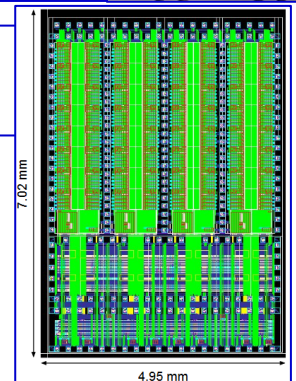
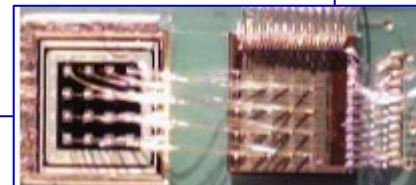

The added value of Coordination within ePIC

Worldwide crisis of h testbeam availability starting in Fall 2026:

- FNAL without near perspectives
- CERN shutdown moving to Hi-Lumi → global pressure for CERN testbeams in 2026

ePIC in front of strategic needs:

- Completing engineering design → validation in h testbeam strategic !

ePIC applied for various CERN beamtests in 2026:

- Strategy: coordination, enhance synergies and have a single ePIC interface
- All needs could be satisfied !

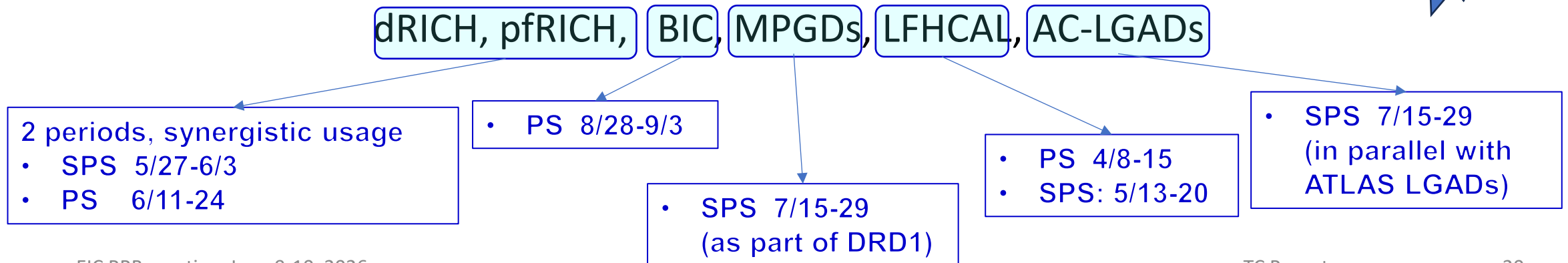

OUTLOOK

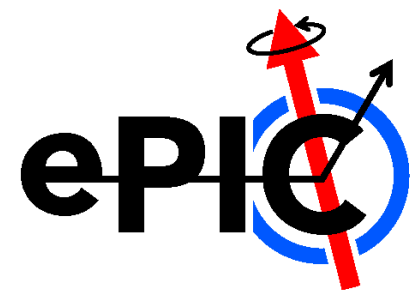

- The ePIC detector, a reminder of the key points
- Intense ePIC detector activity towards engineering the subsystems
- Deeper assessment to the detector performance
- Resources generated by the Collaboration engagement
- Summarizing

ePIC performance: background, the big challenge

DIS cross-section is low. Therefore, the physics background represent a major challenge.

rates in kHz	5x41 GeV	5x100 GeV	10x100 GeV	10x275 GeV	18x275 GeV	Vacuum
Total ep	12.5 kHz	129 kHz	184 kHz	500 kHz	83 kHz	
hadron beam gas	12.2kHz	22.0kHz	31.9kHz	32.6kHz	22.5kHz	10000Ahr
	131.1kHz	236.4kHz	342.8kHz	350.3kHz	241.8kHz	100Ahr
electron beam gas (Bremsstrahlung scatterings)	2181.97 kHz	2826.38 kHz	3177.25 kHz	3177.25 kHz	316.94 kHz	10000Ahr
electron beam gas (Coulomb losses - w/ collimators)		116.57 kHz		29.56 kHz	0.86 kHz	10000Ahr
electron intrabeam (Touschek losses - w/ collimators)		1112.3 kHz		233.5 kHz	0.55 kHz	
DIS eA	kHz	kHz	kHz	/	/	
hadron beam (Au) gas	7.36kHz	10.3kHz	10.3kHz	/	/	10000Ahr
	79.1kHz	110.7kHz	110.7kHz	/	/	100Ahr
electron SR		36608 MHz		36608 MHz	3324 MHz	

Differently affecting the various subsystems

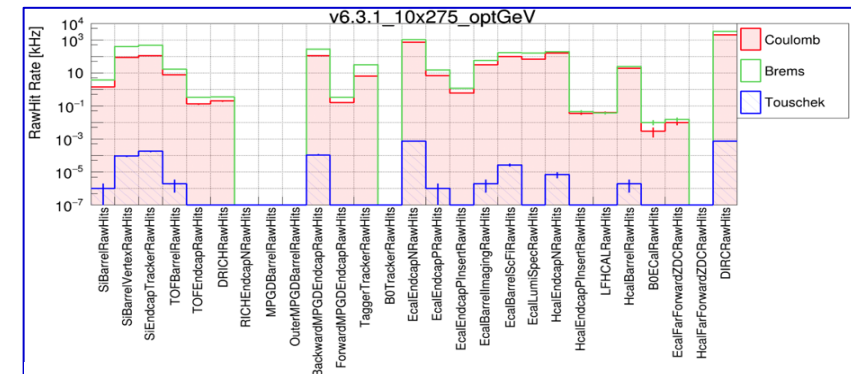

Among 2026 ePIC Collaboration priorities: properly add background contribution to simulated event samples to access the impact of the background challenges

These ongoing studies illustrated by examples in the next slides.

Inner tracking and synchrotron radiation



Synchrotron radiation mainly affects elements of the tracking systems.

- Moderated by $10\mu\text{m}$ Au coating of the beam pipe in the IR

SVT Hit Map

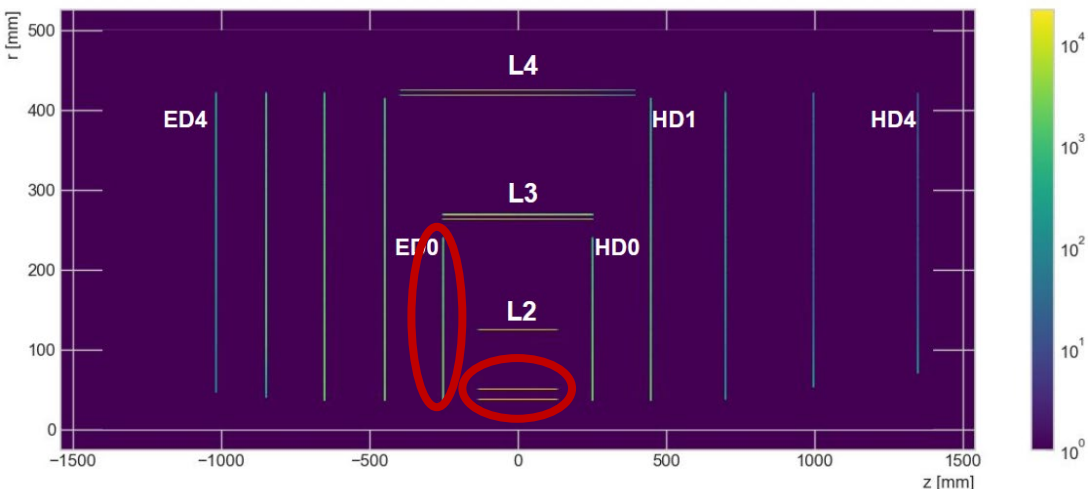

Tracking Performance

Au coating thickness	≥ 4 hits per track		≥ 5 hits per track	
	Efficiency	Purity	Efficiency	Purity
5 μm	0.708	0.091	0.668	0.909
10 μm	0.863	0.819	0.822	0.982

Layer name	Total hits	hits on one single RSU (20x20mm)	Tile (9.8x3.5mm)
E-Si Disk 4	30,796	46	12
E-Si Disk 3	144,894	394	71
E-Si Disk 2	222,634	1326	212
E-Si Disk 1	231,321	1718.5	230
E-Si Disk 0	129,168	1611.5	258
H-Si Disk 0	111,486	1405.5	201
H-Si Disk 1	155,315	1301	250
H-Si Disk 2	36,345	144.5	35
H-Si Disk 3	6,602	137	28
H-Si Disk 4	5,001	86	18
L0	360,929	4330	594
L1	251,520	2188.5	250
L2	154,420	538	73
L3	493,530	711.5	110
L4	314,902	217.5	39

All background sources included; SR is prevalent.

Adequate tiling allows for manageable band width

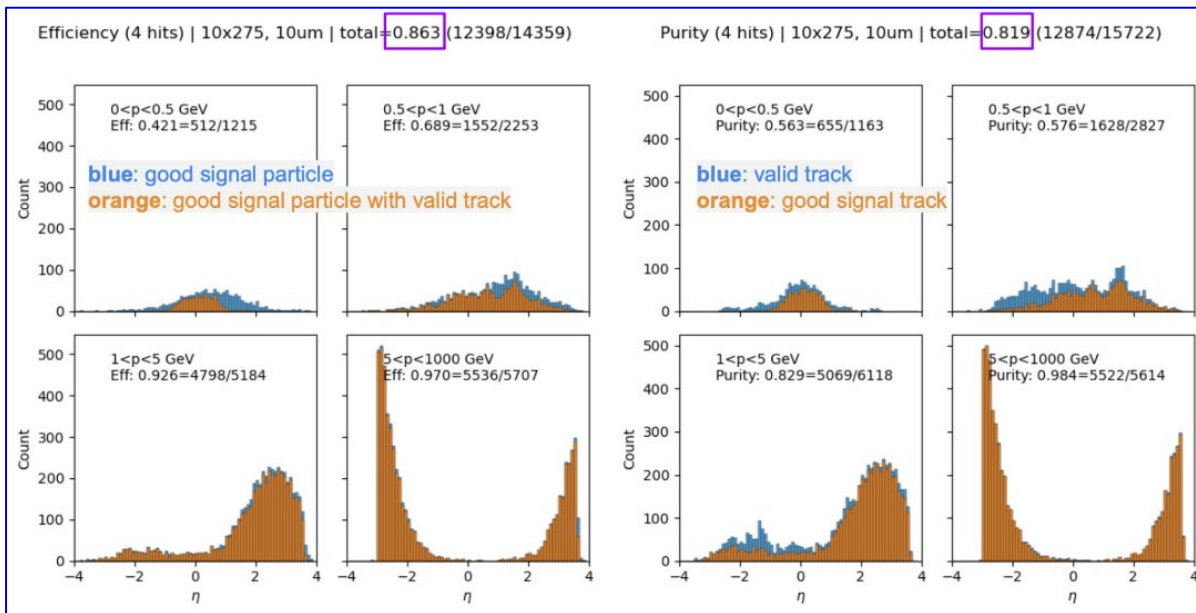

Impact of the background on ECAL performances



EEEMCAL

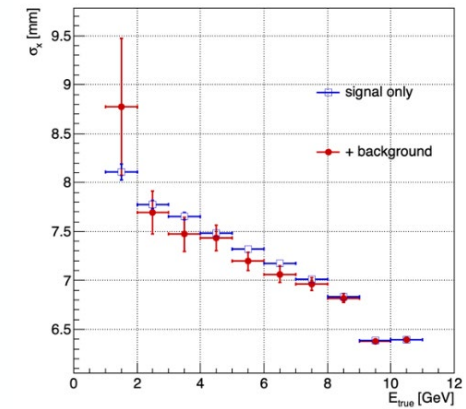
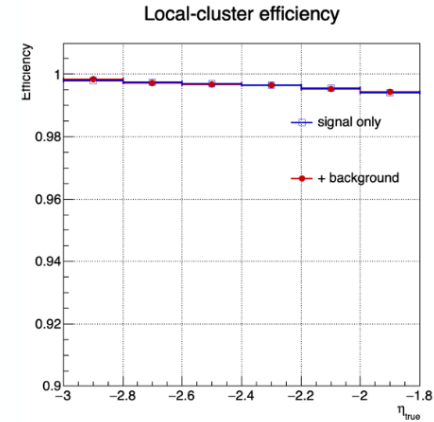
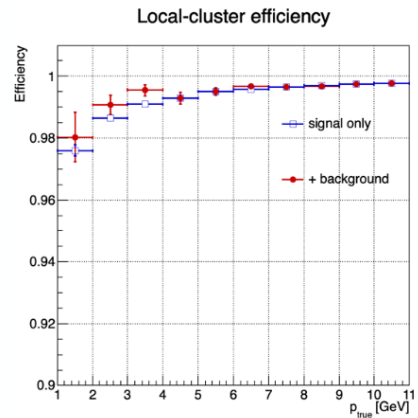

FEMCAL

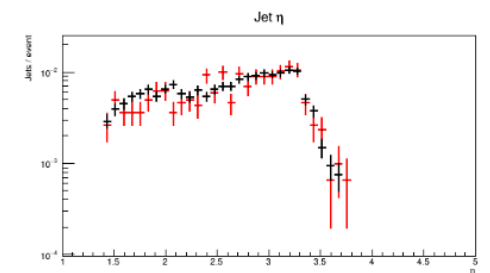
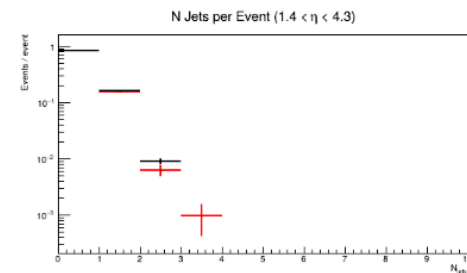
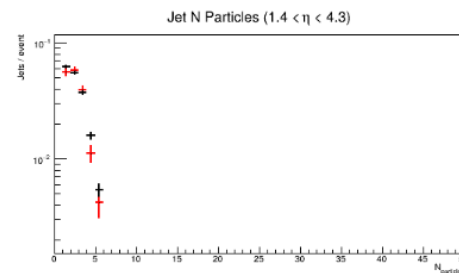
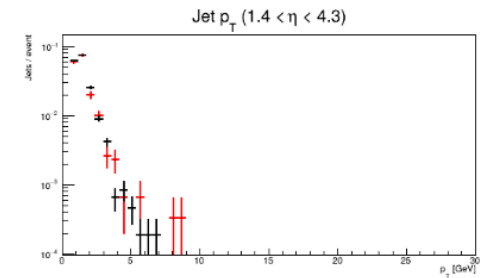
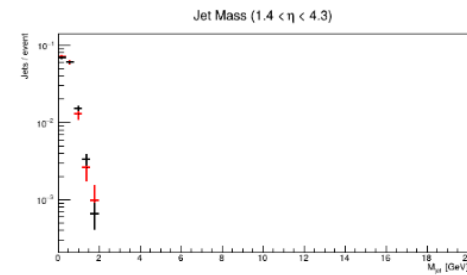
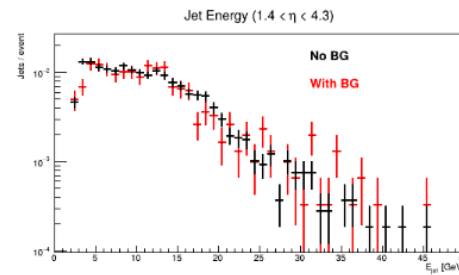

Background and photosensor ageing



pfRICH case

Signal Hit Maps

Signal Hits /cm²/fb⁻¹

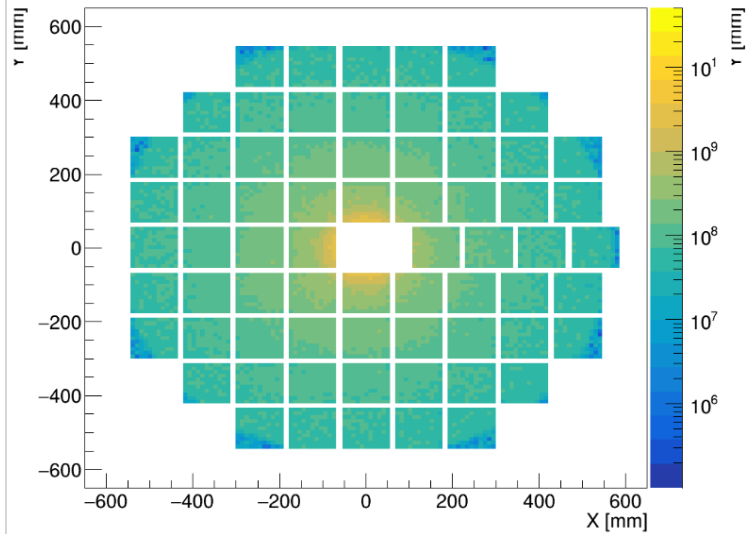

Background impact:
~ 1 order of magnitude
increase in hit rate

Background + Signal Hit Maps

Total Hits /cm²/fb⁻¹

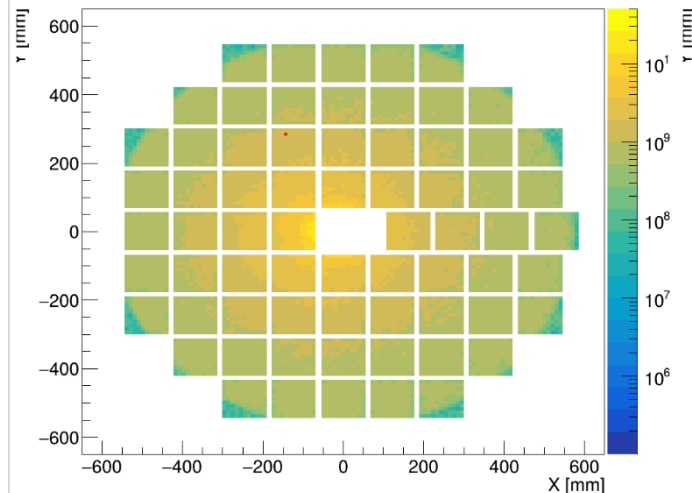

Hit rates can be translated in accumulated charge over operation time and compared with the ongoing ageing studies to confirm the choice of the **HRPPD** photosensors

Current estimates depending on operative gain:

0.05 – 0.5 C/cm²/year

Resulting in a negligible QE decrease over 10ys of operation according to the preliminary ageing studies

ePIC performance: background, the big challenge

Ongoing background studies allow to confirm the overall detector design versus:

- Electronics/read-out/DAQ model and data flow
- Subsystem performance
- Global detector performance
- Sensor ageing
- Radiation damages

The outcome of these studies will be included in the ePIC Detector (pre)TDR, a major consolidation step versus the approval of this subproject

DRAFT
ePIC PDR
January 16, 2026

The ePIC Detector Preliminary Technical Design Report



OUTLOOK

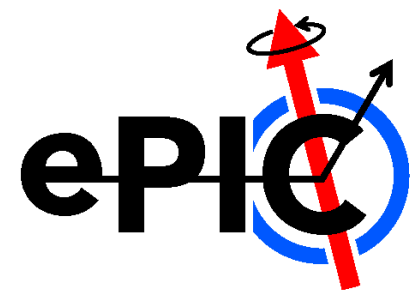

- The ePIC detector, a reminder of the key points
- Intense ePIC detector activity towards engineering the subsystems
- Deeper and deeper assessment to the detector performance
- Resources generated by the Collaboration engagement
- Summarizing

Collaboration workforce

2026 Statement of Service Survey : **293 FTE**

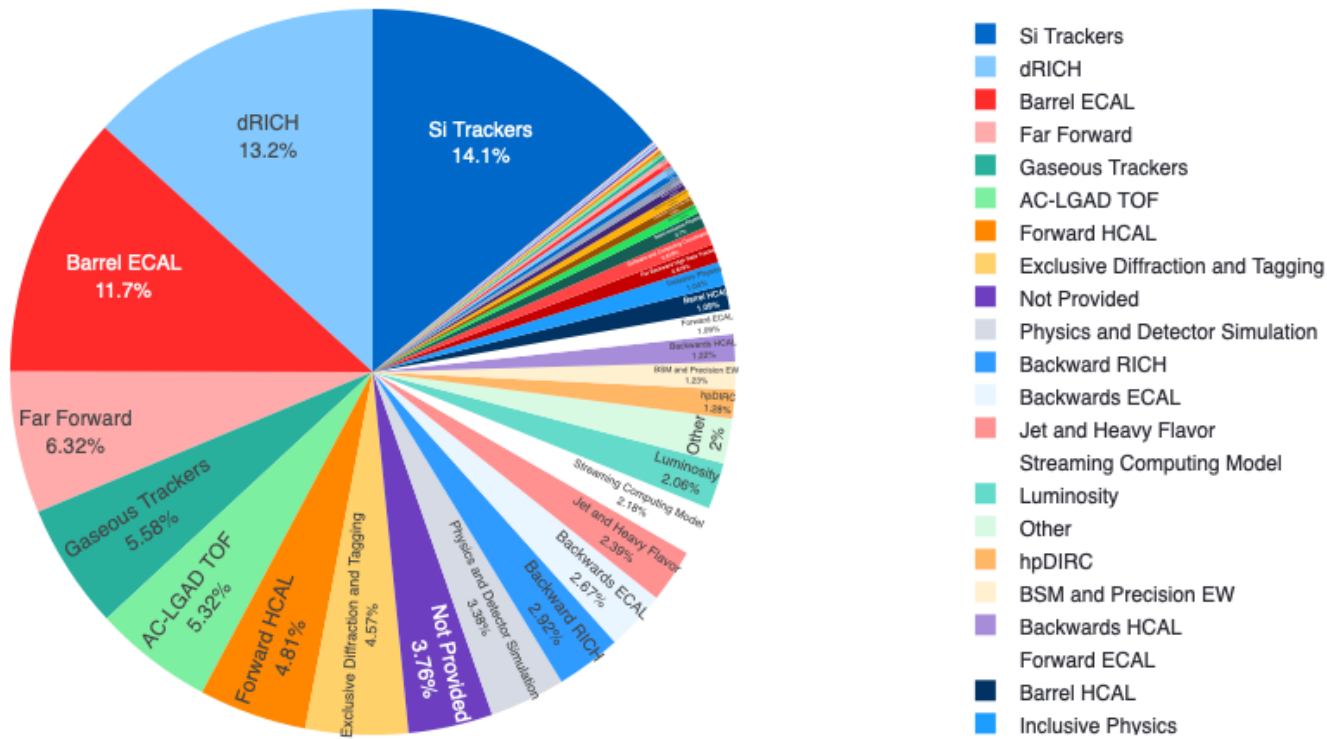

ePIC Workforce Progress

- The current FTE commitment has to be compared with 1y ago:

- 2025 survey
(data collected at the end of 2024)

199.5 FTE

“In-kind” being generated by the Collaboration engagement

ePIC Central Detector

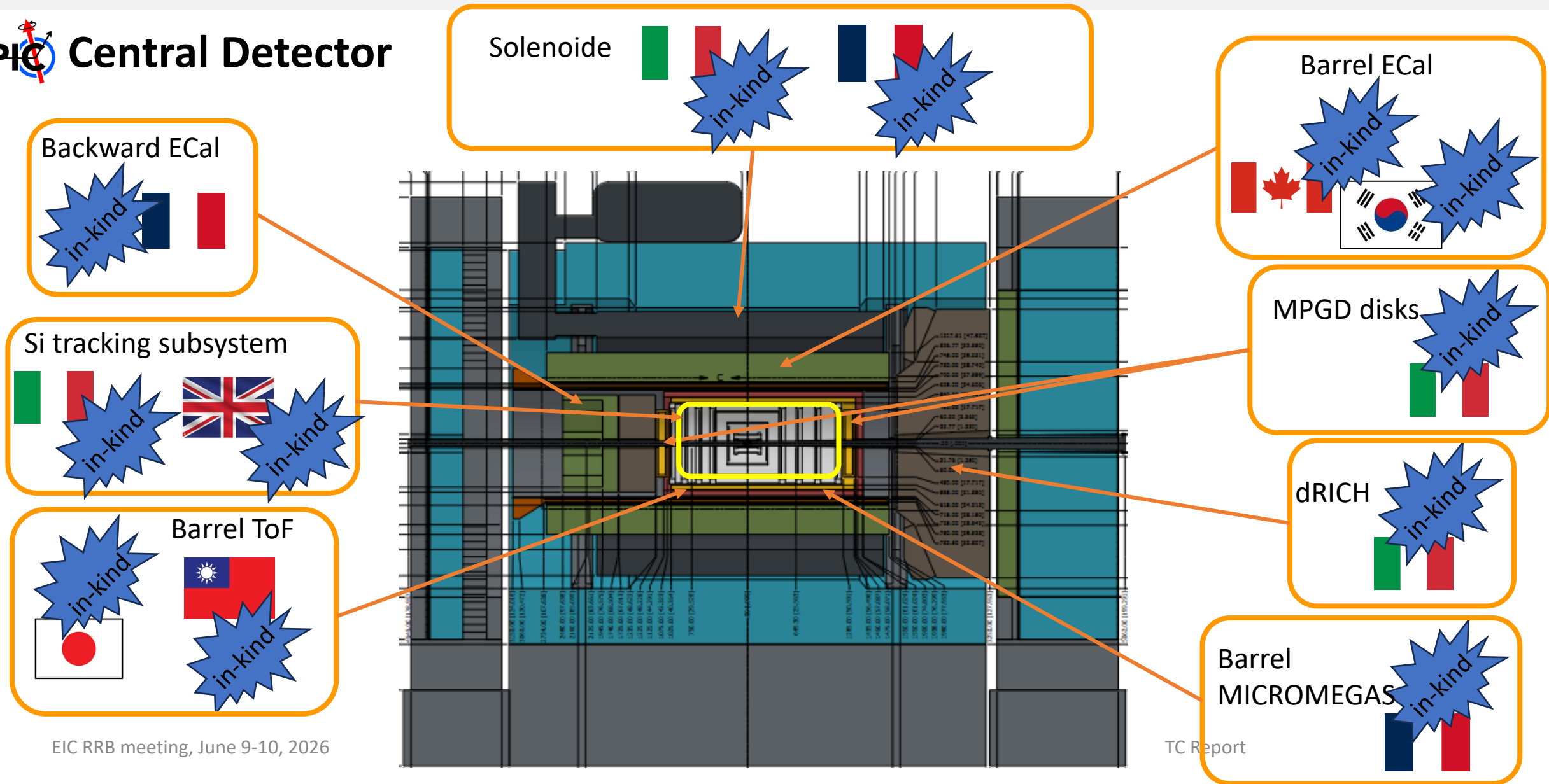

“In-kind” being generated by the Collaboration engagement

ePIC Central Detector

Backward ECal



in-kind

Si tracking subsystem



in-kind

Barrel ToF

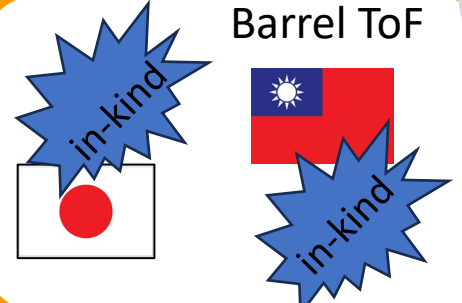

in-kind

Solenoid



in-kind

Here and in the following slide refers to **substantial components of the subsystem provided in-kind.**

All international Collaborators provide in-kind Workforce.

Barrel ECal

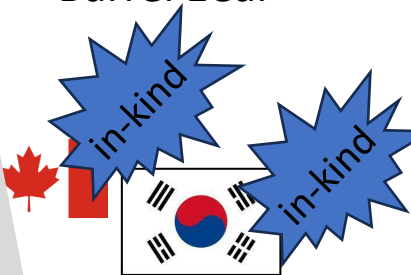

in-kind

MPGD disks



in-kind

CH



in-kind

Barrel MICROMEGAS



in-kind

“In-kind” being generated by the Collaboration engagement

ePIC Far Detectors

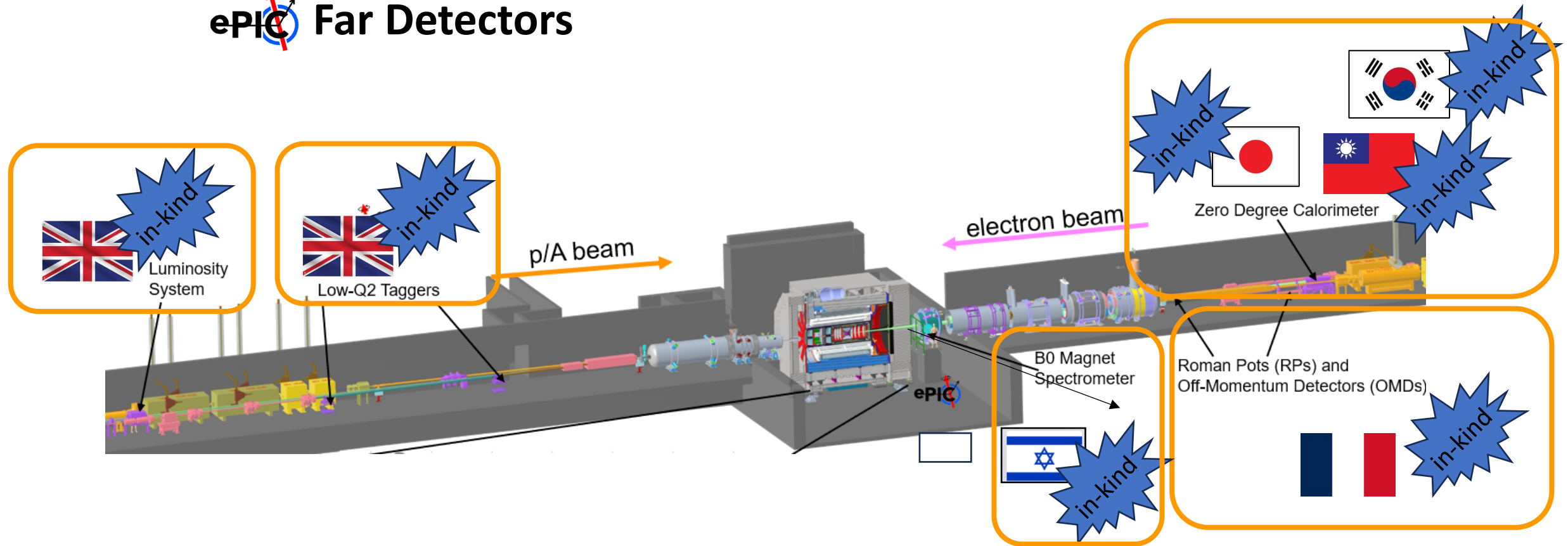

OUTLOOK

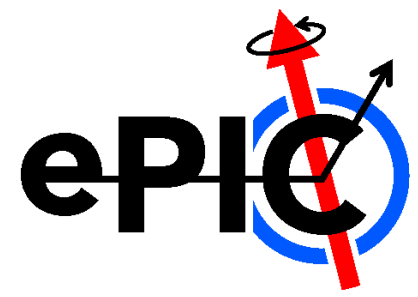

- The organizational model of the ePIC detector, a reminder
- Supporting the detector optimization
- Intense ePIC detector activity towards engineering the subsystems
- The ePIC detector in the preTDR
- Resources generated by the Collaboration engagement
- Summarizing

- The intense activity of the ePIC Collaboration results in a substantial progress toward the **ePIC Detector realization** also thanks to the synergistic integration of the **EIC Project** and the **ePIC Collaboration**
- **The ePIC Collaboration**
 - Brings in scientific workforce
 - 2026: ~300 FTE committed;
 - Allows for a holistic approach (hardware complemented by simulation and physics studies);
 - Opens the way to in-kind contributions;
 - Is intensively at work for the detector finalization
 - Background impact;
 - The present ePIC Detector status is largely due to the Collaboration effort



Thank you