

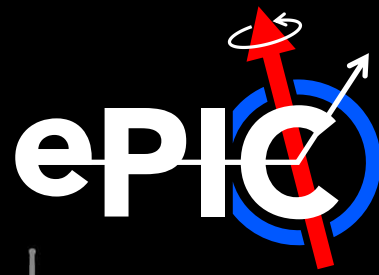

UNIVERSITY OF
BIRMINGHAM



ePIC SVT Powering Trees

James Glover

Electronics and DAQ Working Group

Thu, 16th April 2026



SVT sub-systems

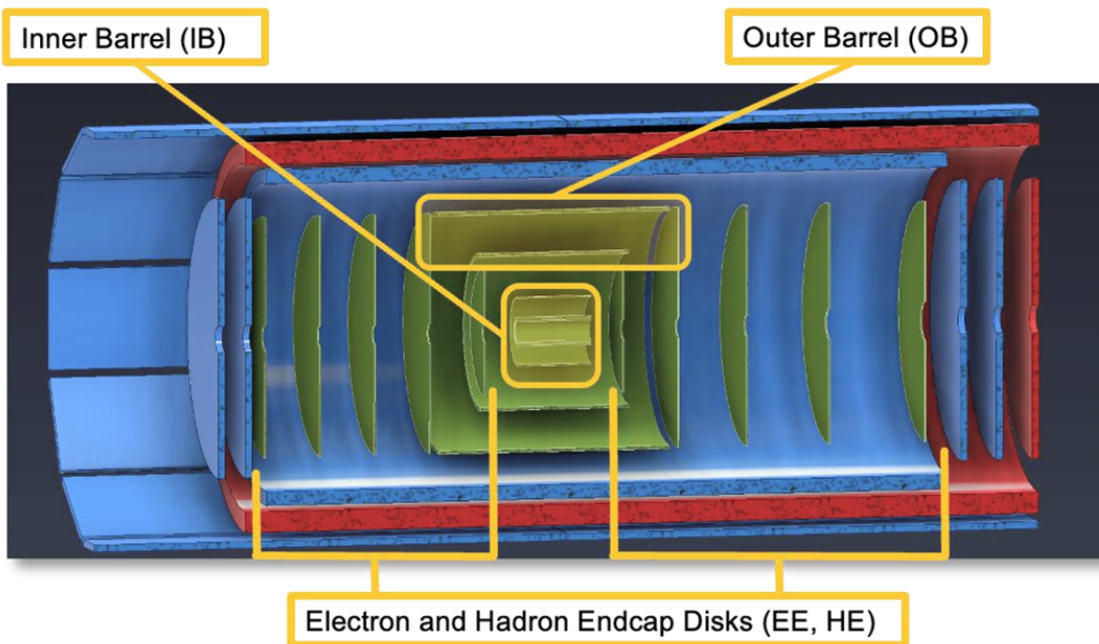
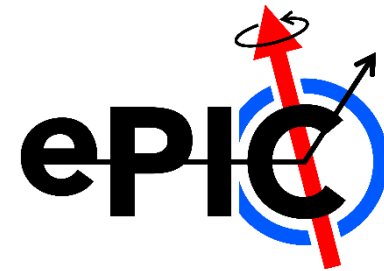

- Inner Barrel (IB).
 - Sensor: **MOSAIX**
 - Power segmentation: **per MOSAIX segment**
 - Readout connections: **eight per segment**
 - Powering scheme: **direct power**
 - Slow Control scheme: **seven direct S/C signals**
- Outer Barrel (OB) and Endcap Disks.
 - Sensor: **EIC-LAS (with supporting AncASIC)**
 - Power segmentation: **per Flexible Printed Circuit**
 - Readout connections: **one per EIC-LAS**
 - Powering scheme: **serial power**
 - Slow Control scheme: **daisy chained ePIC_SC interface per FPC**

Outer Barrel (OB) and Endcap Disks

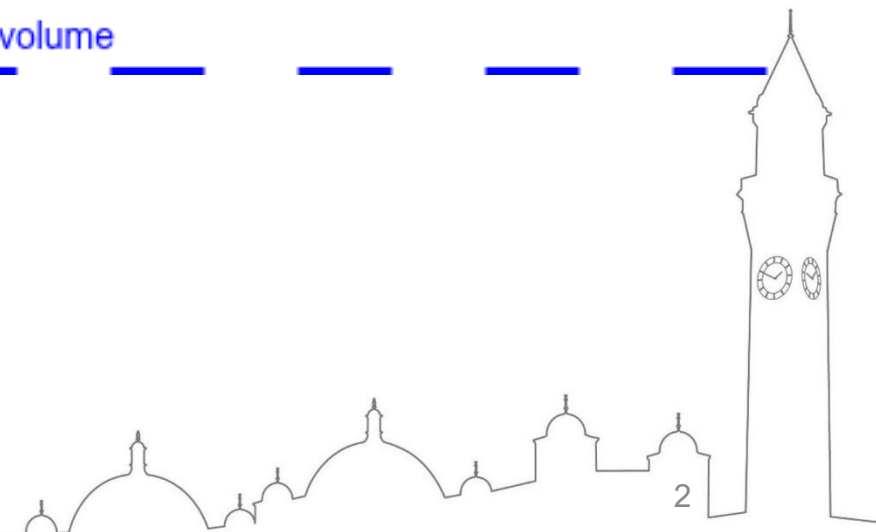
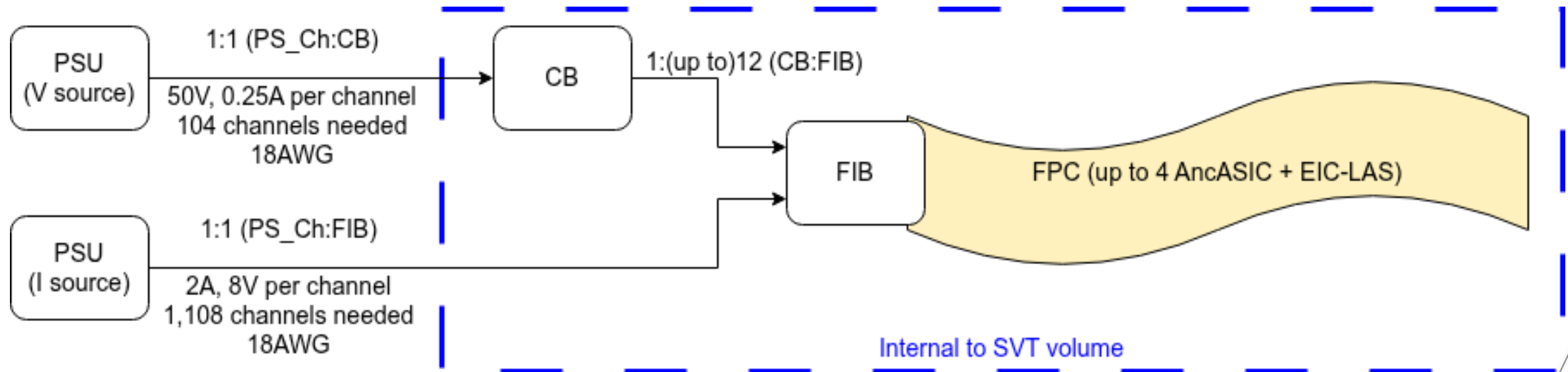
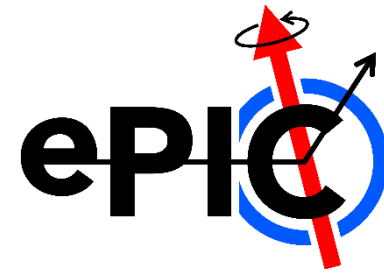

Power Distribution Tree

Sub-Detector: SVT – OB+Disks – V-supplies (for readout) Type: LV

Power supply

Patch Panel

Conversion + Distribution

Detector



Cable



Cable

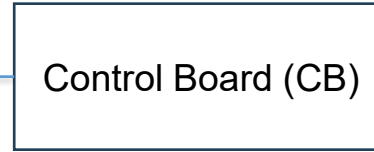

Cable

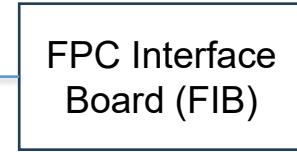

#Ch: 104
Ch V/I: 50V/0.25A
Model:
Qty:

On-detector: Y
Qty:

On-detector: Y
Qty: 104
DC/DC: bPOL48 (48-10V)
Qty: 1/CB
DC/DC: bPOL12 (10-2.5V)
Qty: 1/CB
DC/DC: bPOL2v5 (2.5-1.2V)
Qty: 1/CB

To Adapter: Y/N
To FEB: Y/N

Wire Gauge: 10AWG
Current/Wire: ~250 mA
Part#:
Length:
Qty: 208

104 ch (source+ret)

Wire Gauge: 18AWG
Current/Wire: ~250 mA
Part#:
Length:
Qty: 208

Wire Gauge: 30AWG
Current/Wire: < 55 mA
Part#:
Length:
Qty: 4,432

Power Loss:



~10%

40%

2%

Power Distribution Tree

Sub-Detector: SVT – OB+Disks – I-supplies (for active Si) Type: LV

Power supply

Patch Panel

Detector

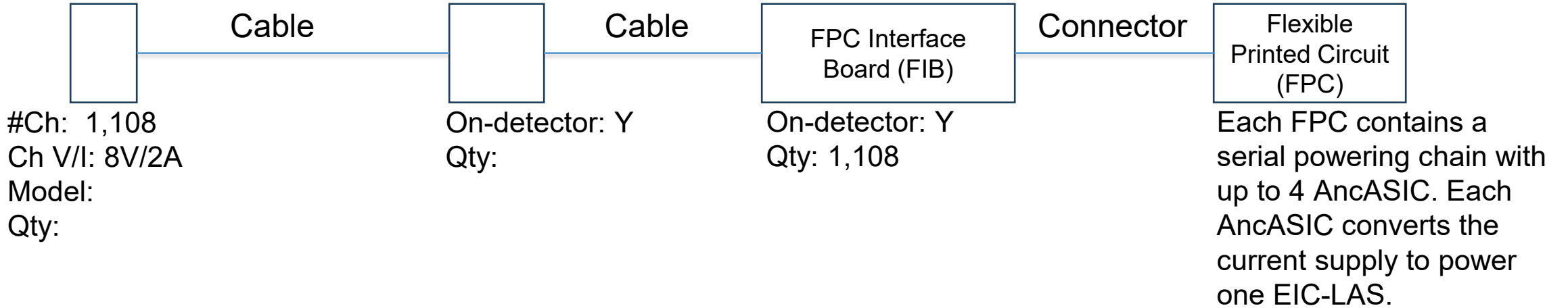

5*S-LDO/AncASIC

Wire Gauge: 10AWG
Current/Wire: < 2 A
Part#:
Length:
Qty: 2,216

1,108 ch
(source+ret)

Wire Gauge: 18AWG
Current/Wire: < 2 A
Part#:
Length:
Qty: 2,216

Power Loss:



~10%

TBD

TBD

Inner Barrel (IB)

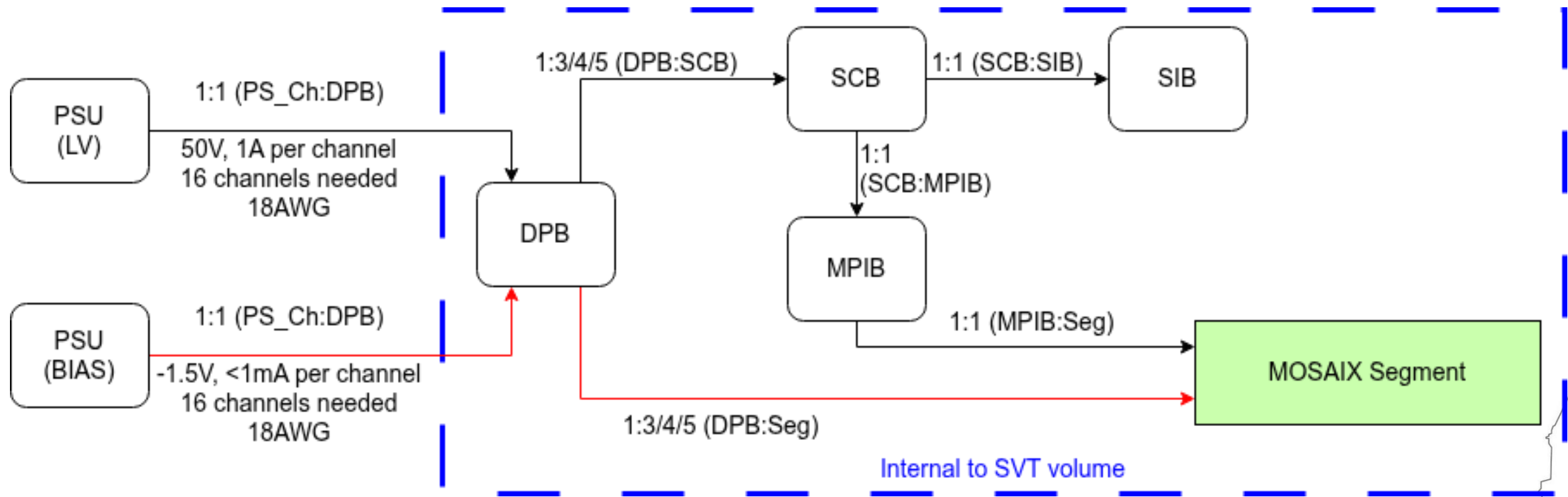
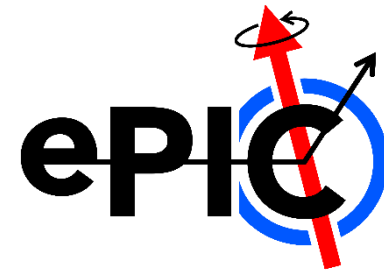

Power Distribution Tree

Sub-Detector: SVT – IB

Type: BIAS

Power supply

Patch Panel

Conversion + Distribution

Detector



Cable



Cable

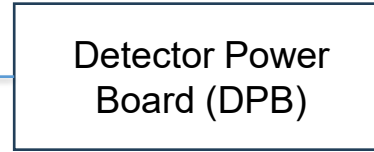

Cable



#Ch: 16
Ch V/I: -1.5V/<1mA
Model:
Qty:

On-detector: Y
Qty:

On-detector: Y
Qty: 16
LDO: linPOL12 (-1.5V to -1.2V)
Qty: 1/DPB

Wire Gauge: 10AWG
Current/Wire: < 1 mA
Part#:
Length:
Qty: 32

16 ch (source+ret)

Wire Gauge: 18AWG
Current/Wire: < 1 mA
Part#:
Length:
Qty: 32

Wire Gauge: 30AWG
Current/Wire: < 1 mA
Part#:
Length:
Qty: 32

Power Loss:

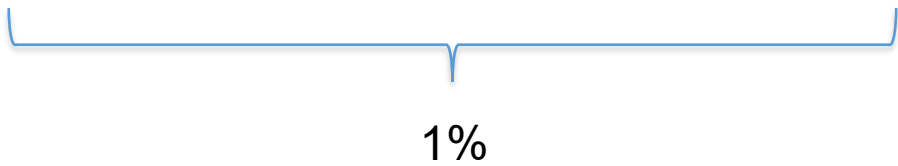

20%

1%

Power Distribution Tree

Sub-Detector: SVT – IB (for readout)

Type: LV

Power supply

Patch Panel

Conversion +
Distribution

Conversion

Cable
or FPC



Cable



Cable

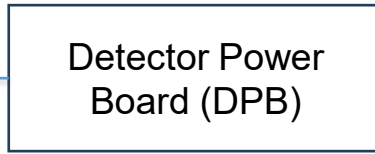

Cable



Cable
or FPC

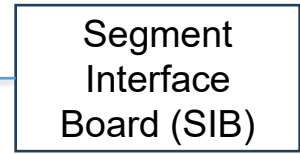

#Ch: 16
Ch V/I: 50V/1A
Model:
Qty:

On-detector: Y
Qty:

On-detector: Y
Qty: 16
DC/DC: bPOL48 (48-10V)
Qty: 1/DPB
DC/DC: bPOL12 (10-2.5V)
Qty: 1/DPB
DC/DC: bPOL2v5 (2.5-1.2V)
Qty: 1/DPB

On-detector: Y
Qty: 68
DC/DC: bPOL12 (10-2.5V)
Qty: TBD
DC/DC: bPOL2v5 (2.5-1.2V)
Qty: TBD

Wire Gauge: 10AWG
Current/Wire: ~1 A
Part#:
Length:
Qty: 32

**16 ch
(source+ret)**

Wire Gauge: 18AWG
Current/Wire: ~1 A
Part#:
Length:
Qty: 32

Wire Gauge: 30AWG
Current/Wire: 0.8A
Part#:
Length:
Qty: 136

**68 SCBs
(source+ret)**

Wire Gauge: TBD
Current/Wire: < 55 mA
Part#:
Length:
Qty: 136

**68 SIBs
(source+ret)**

Power Loss:

3%

11%

1%

40%

TBD

TBD

Power Distribution Tree

Sub-Detector: SVT – IB (for active Si)

Type: LV

Power supply

Patch Panel

Conversion +
Distribution

Conversion

Cable
+FPC



Cable



Cable

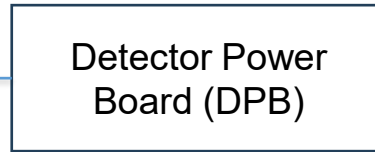

Cable

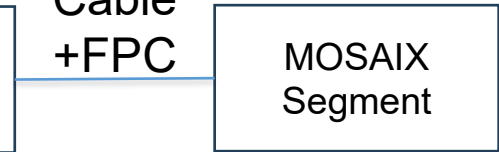
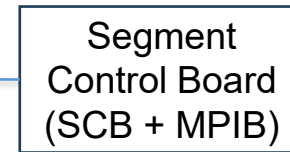

#Ch: 16
Ch V/I: 50V/?A
Model:
Qty:

On-detector: Y
Qty:

On-detector: Y
Qty: 16
DC/DC: bPOL48 (48-10V)
Qty: 1/DPB
DC/DC: bPOL12 (10-2.5V)
Qty: 1/DPB
DC/DC: bPOL2v5 (2.5-1.2V)
Qty: 1/DPB

On-detector: Y
Qty: 68
DC/DC: bPOL12 (10-2.5V)
Qty: TBD
DC/DC: bPOL2v5 (2.5-1.2V)
Qty: TBD

Wire Gauge: 10AWG
Current/Wire: ~1 A
Part#:
Length:
Qty: 32

**16 ch
(source+ret)**

Wire Gauge: 18AWG
Current/Wire: ~1 A
Part#:
Length:
Qty: 32

Wire Gauge: 30AWG
Current/Wire: 0.8A
Part#:
Length:
Qty: 136

**68 SCBs
(source+ret)**

Wire Gauge: TBD
Current/Wire: 1.2A
Part#:
Length:
Qty: 544

**68 Segs,
4 domains
(source+ret)**

Power Loss:

3%

11%

1%

40%

TBD

TBD



UNIVERSITY OF
BIRMINGHAM

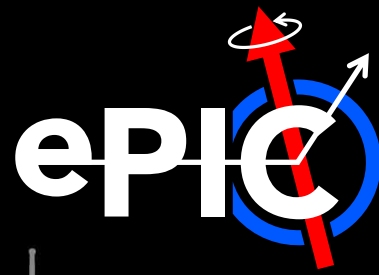

Thank you very much!

Any questions?

