

# ePIC ZDC HCAL

**Sean Preins (UCR)**

Incremental Preliminary Design and Safety Review of the EIC Auxiliary Detectors

April 20<sup>th</sup>, 2026

Electron-Ion Collider

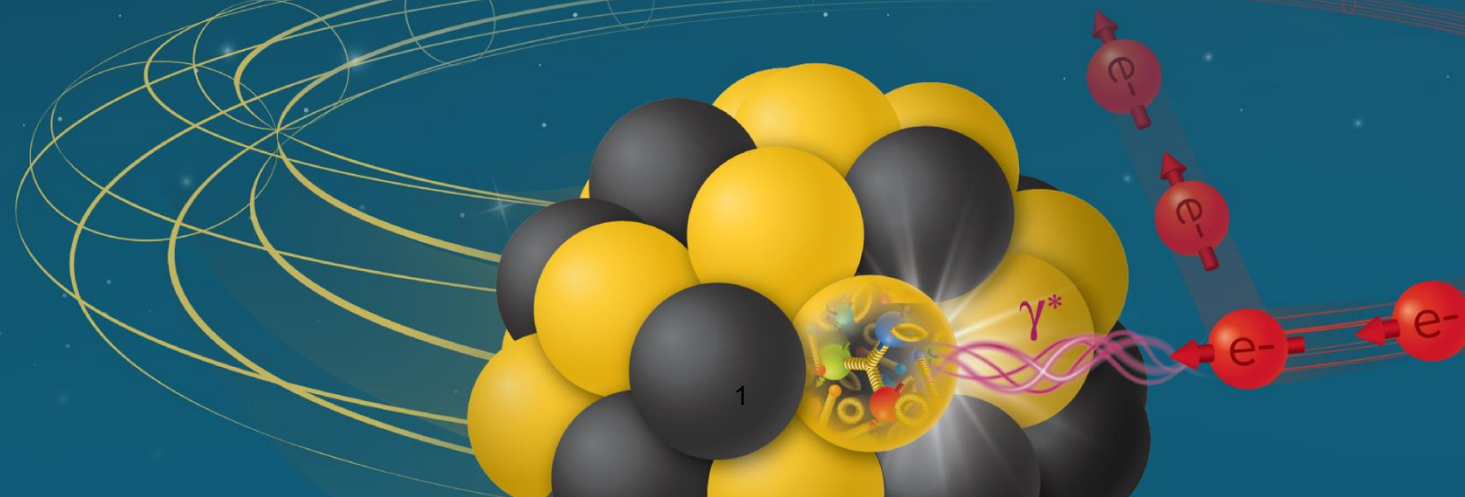

# Outline

---

- ZDC HCAL Requirements
- Detector Overview
- SiPM-on-tile Performance Studies
  - Generation I Prototype (Jefferson Lab)
  - Generation II Prototype (STAR)
  - Generation III Engineering Test Module (Jefferson Lab, NSRL)
- Summary and To-Do

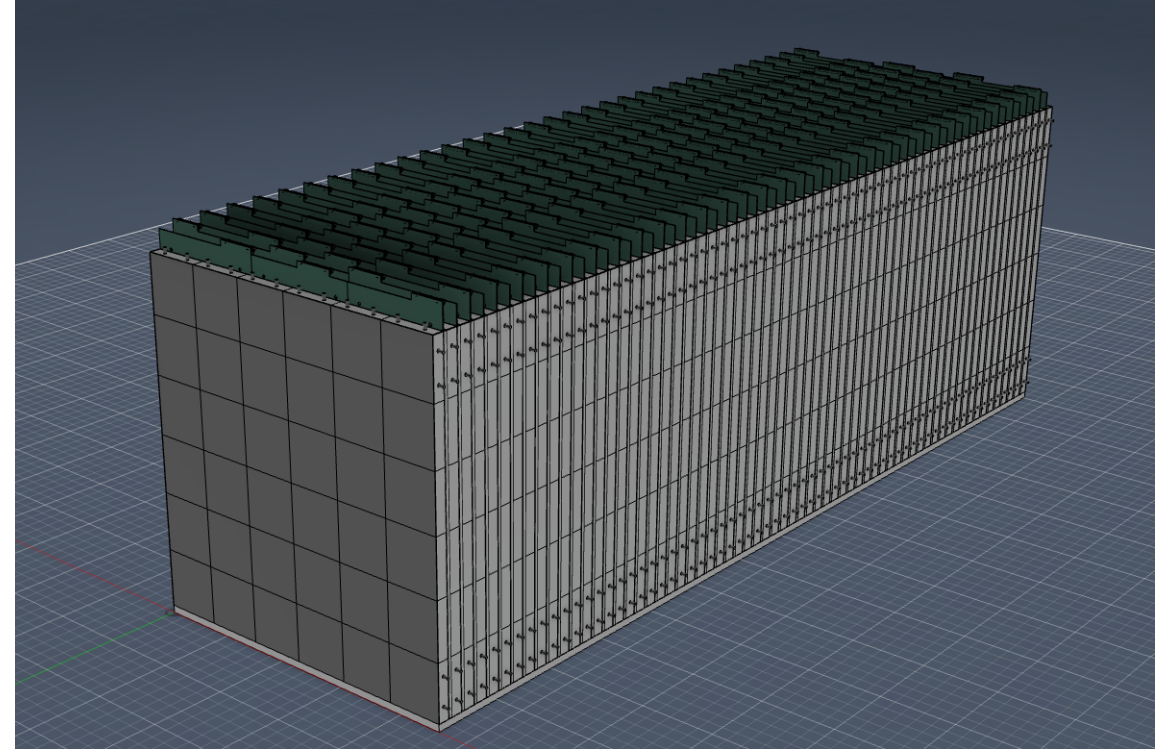

# ZDC HCAL Requirements

---

- ✓ The Zero Degree Calorimeter should provide measurements of neutral particles (**neutrons** and photons)
- ✓ ZDC will provide theta coverage in the range  $0 < \theta < 4$  mrad (aperture limit, symmetric in phi).
- ✓ ZDC system active area will have dimensions 60 [cm] in X and 60 [cm] in Y and  $< 200$  [cm] in Z
- ✓ ZDC will provide good PT ( or t ) -measurements of far-forward neutral particles (photons and **neutrons** )
- Neutrons
  - ✓ Angular resolution  $\sigma(\theta) < 3\text{mrad} / \sqrt{E}$
  - ✓ Energy measurements  $\sigma(E)/E < 50\%/\sqrt{E} + 5\%$

<https://eic.jlab.org/Requirements/>

# ZDC HCAL Requirements, Angular Resolution

- Simulation was updated from using hexagonal tiles to square tiles
- Updated model shows angular resolution is still well below the YR requirement
- Angular resolution can likely be improved further via GNN reconstruction

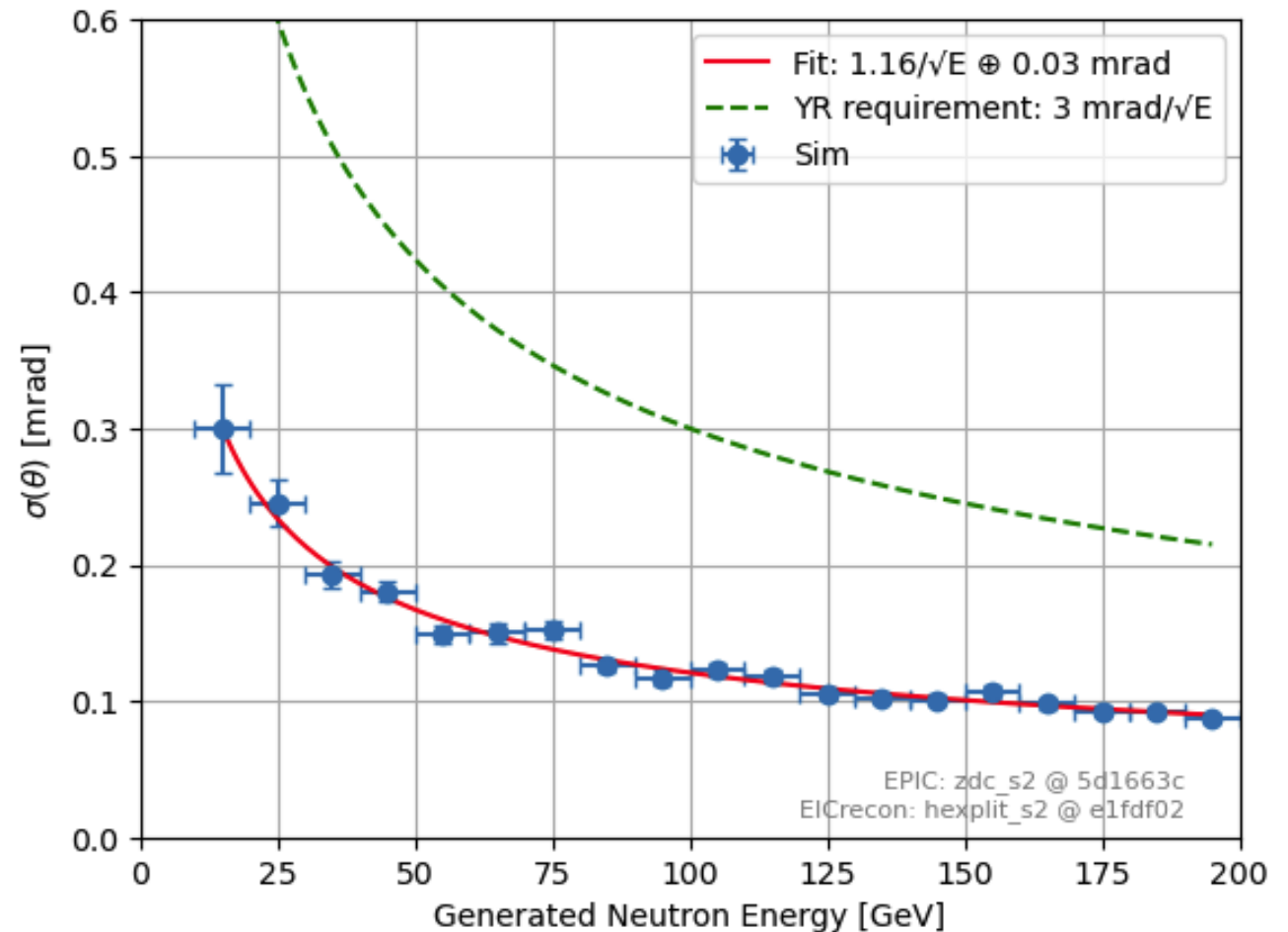

# ZDC HCAL Requirements, Energy Resolution

- Updated simulation has a comparable resolution to the strawman reconstruction when using hexagonal tiles
- As before, the energy resolution is expected to go below the YR requirement after a GNN reconstruction

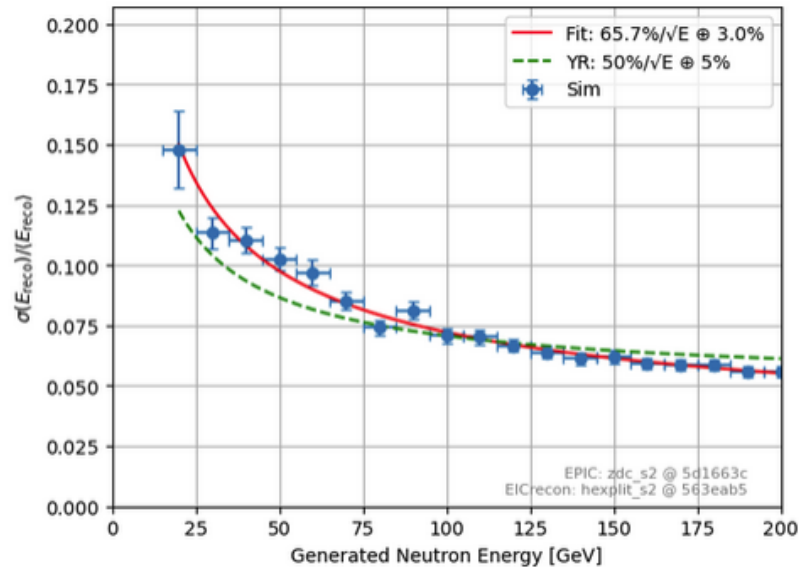

Square Tiles

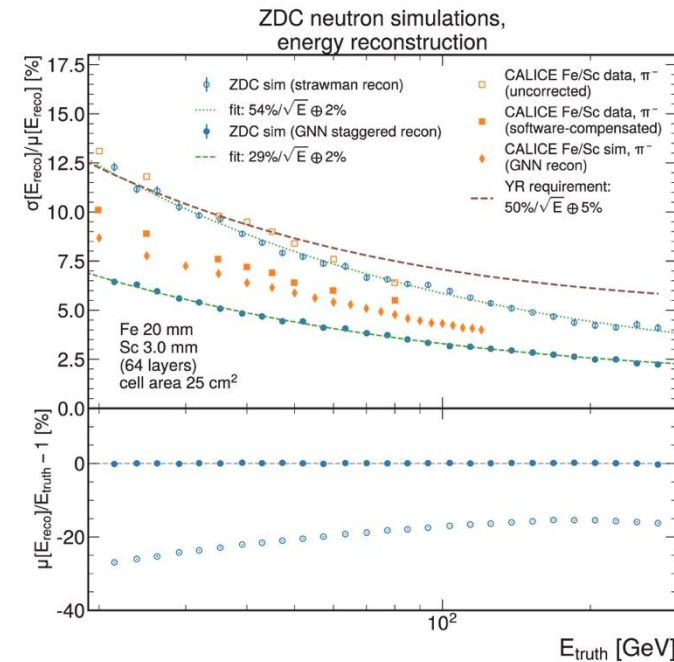

Hexagonal Tiles

R. Milton, S. J. Paul, B. Schmookler, M. Arratia, P. Karande, A. Angerami, F. Torales Acosta, and B. Nachman, "Design and simulation of a sipm-on-tile zdc for the future eic, and its performance with graph neural networks," [Nuclear Instruments and Methods in Physics Research Section A: Accelerators, Spectrometers, Detectors and Associated Equipment 1079 \(2025\) 170613](https://www.sciencedirect.com/science/article/pii/S0168900225004140). <https://www.sciencedirect.com/science/article/pii/S0168900225004140>.

# ZDC HCAL Design Overview

- 64-layer SiPM-on-tile sampling calorimeter
- ASIC-away-of-SiPM readout to reduce cooling and space requirements
- 1.3 mm SiPMs, 48.8mm x 48.8mm tiles same as forward HCAL
- 576 mm x 600 mm x 1755 mm
- 121 / 132 channels per layer, 8096 channels
- Every second layer is offset by half a cell width in each direction to increase effective granularity
- Layers are removable to allow for SiPM annealing to mitigate radiation damage

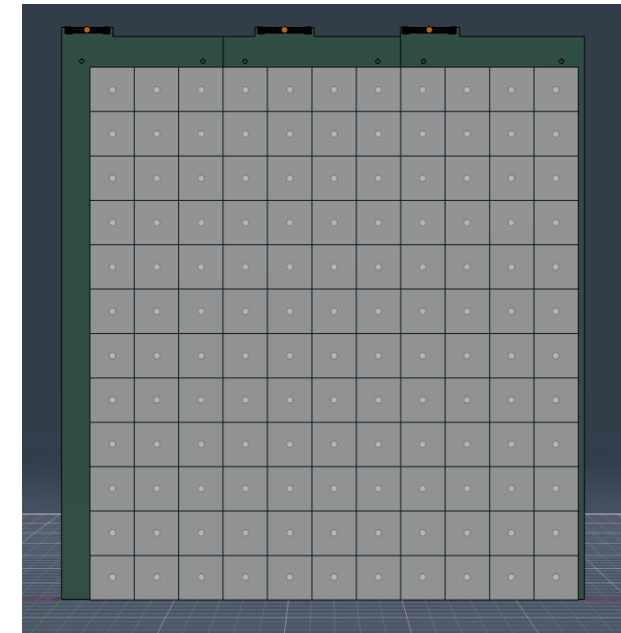
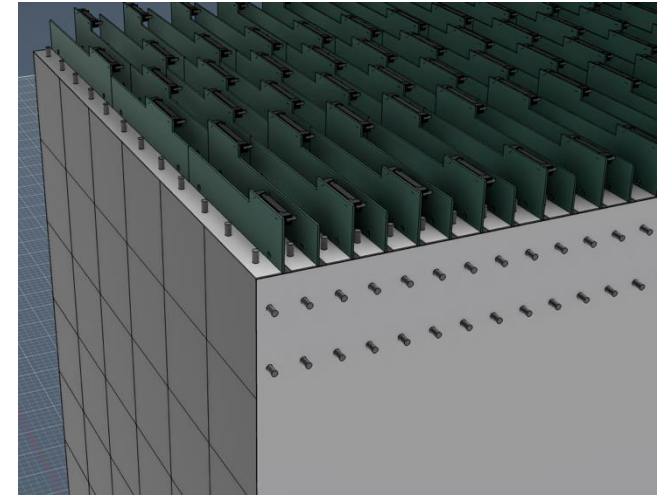

# Performance Studies

---

M. Arratia, L. Garabito Ruiz, J. Huang, S. J. Paul, S. Preins, and M. Rodriguez, “Studies of time resolution, light yield, and crosstalk using sipm-on-tile calorimetry for the future electron-ion collider,” [Journal of Instrumentation 18 no. 05, \(May, 2023\) P05045](#).

M. Arratia, B. Bagby, P. Carney, J. Huang, R. Milton, S. J. Paul, S. Preins, M. Rodriguez, and W. Zhang, “Beam Test of the First Prototype of SiPM-on-Tile Calorimeter Insert for the EIC Using 4 GeV Positrons at Jefferson Laboratory,” [Instruments 7 no. 4, \(2023\) 43](#).

W. Zhang, S. Preins, J. Huang, S. J. Paul, R. Milton, M. Rodriguez, P. Carney, R. Tsiao, Y. Abdelkadous, and M. Arratia, “First-ever deployment of a sipm-on-tile calorimeter in a collider: a parasitic test with 200 gev p p collisions at rhic.,” [Journal of Instrumentation 20 no. 06, \(Jun, 2025\)](#).

J. Huang, S. Preins, R. Tsiao, M. Rodriguez, B. Schmookler, and M. Arratia, “Measurement of sipm dark currents and annealing recovery for fluences expected in epic calorimeters at the electron-ion collider,” 2025. <https://arxiv.org/abs/2503.14622>.

W. Zhang, X. Liang, S. Preins, and M. Arratia, “Calibration of an Irradiated Prototype for the EIC Zero-Degree Calorimeter,” [arXiv:2512.20852 \[physics.ins-det\]](#).

S. Preins, W. Zhang, R. Tsiao, M. Macias, B. Saunders, L. Preet, and M. Arratia, “Beam test of a sipm-on-tile zdc prototype with 5.3 gev positrons at Jefferson laboratory,” [arXiv:2603.14167 \[phys.ins-det\]](#).

# Generation I Prototype

- 40 channel, 10-layer SiPM-on-tile prototype tested at Jefferson Lab in Jan 2023
- Detector response showed good match with GEANT4 simulations
- Prototype employed large square tiles

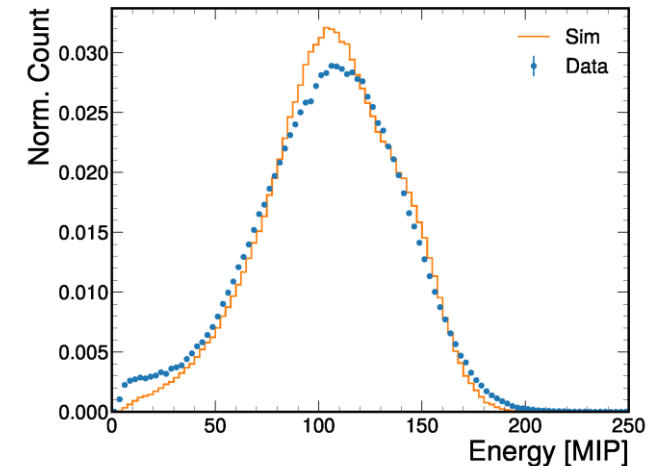
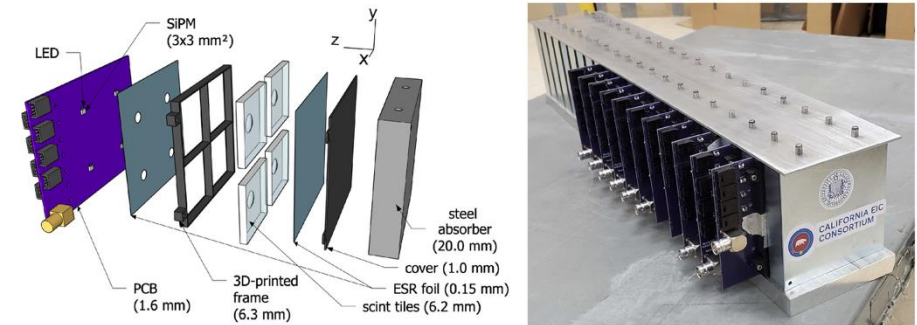
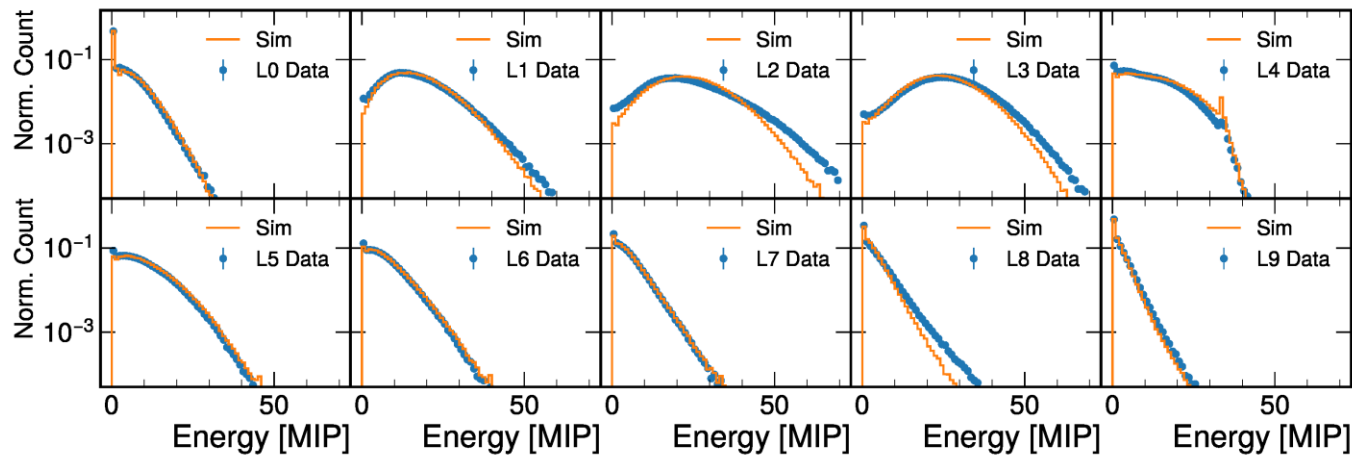

M. Arratia, B. Bagby, P. Carney, J. Huang, R. Milton, S. J. Paul, S. Preins, M. Rodriguez, and W. Zhang, "Beam Test of the First Prototype of SiPM-on-Tile Calorimeter Insert for the EIC Using 4 GeV Positrons at Jefferson Laboratory," [Instruments 7 no. 4, \(2023\) 43](#).

# Generation II Prototype

- 192 channel, 14-layer prototype tested in the STAR experiment hall with 200 GeV pp collisions
- Maintained stable operation after being exposed to  $10^{10} \frac{1\text{-MeV } n_{eq}}{cm^2}$

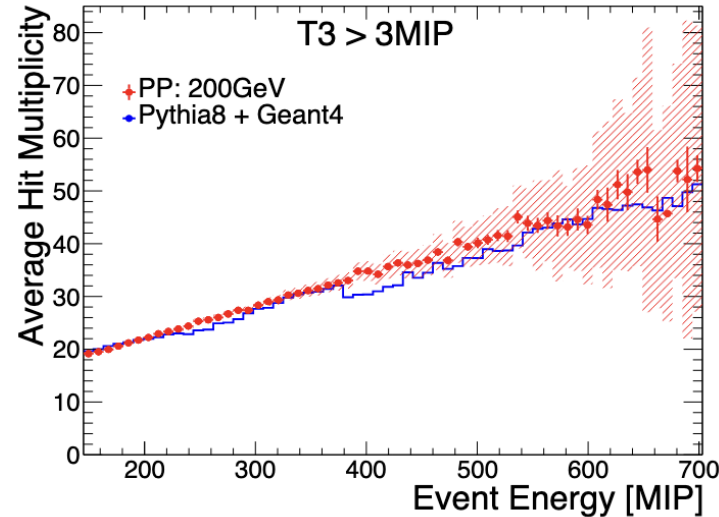
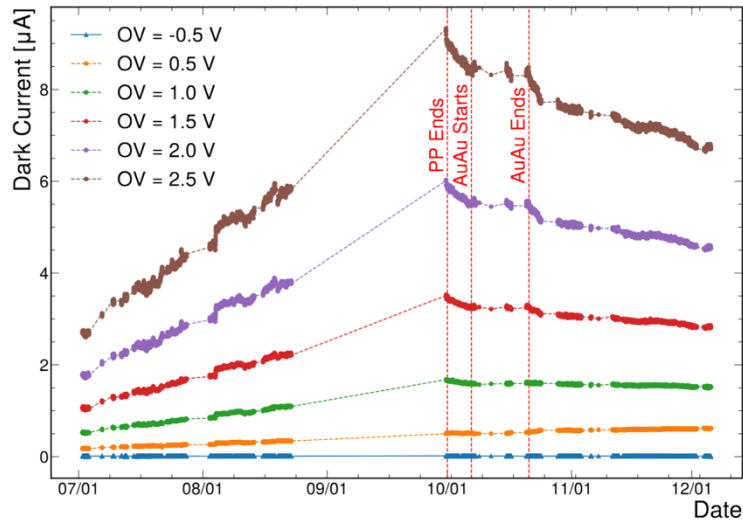

Mix of square and hexagonal tiles

W. Zhang, S. Preins, J. Huang, S. J. Paul, R. Milton, M. Rodriguez, P. Carney, R. Tsiao, Y. Abdelkadous, and M. Arratia, "First-ever deployment of a sipm-on-tile calorimeter in a collider: a parasitic test with 200 gev p p collisions at rhic.," [Journal of Instrumentation 20 no. 06, \(Jun, 2025\).](#)

# Generation III Engineering Test Module

- 370/563 channel SiPM-on-tile calorimeter mimicking the final ZDC design
- 5x5 grid of 4 mm thick tiles per layer, with staggered layers
- Tested with 5.3 GeV positrons at Jefferson Lab, and irradiated at NSRL
- Provided valuable insight into the design, construction, operation, and calibration for the full ZDC

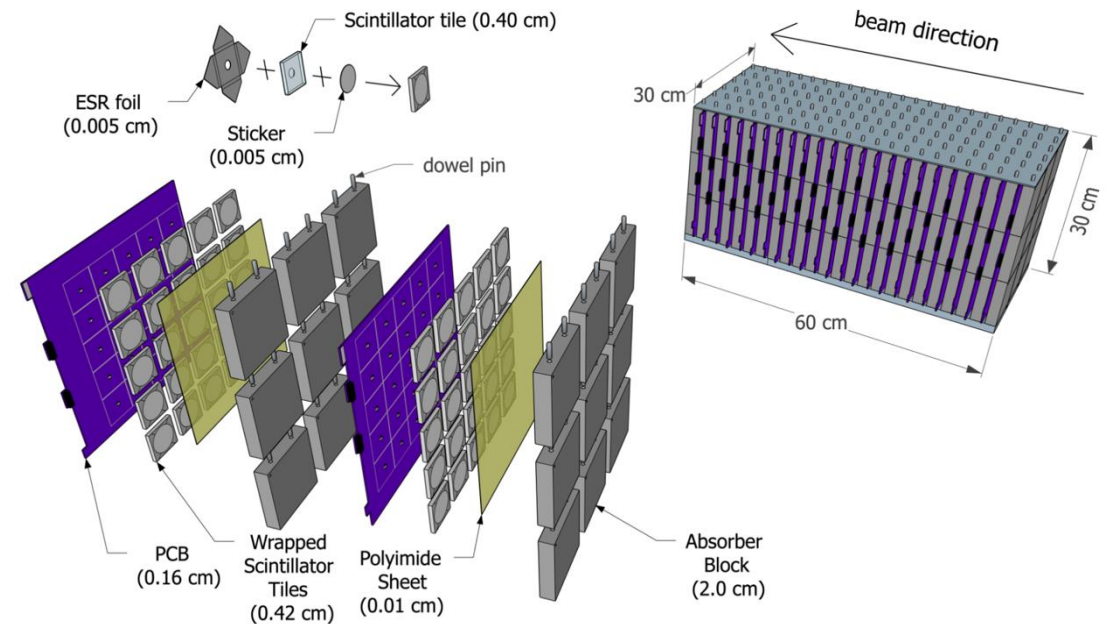
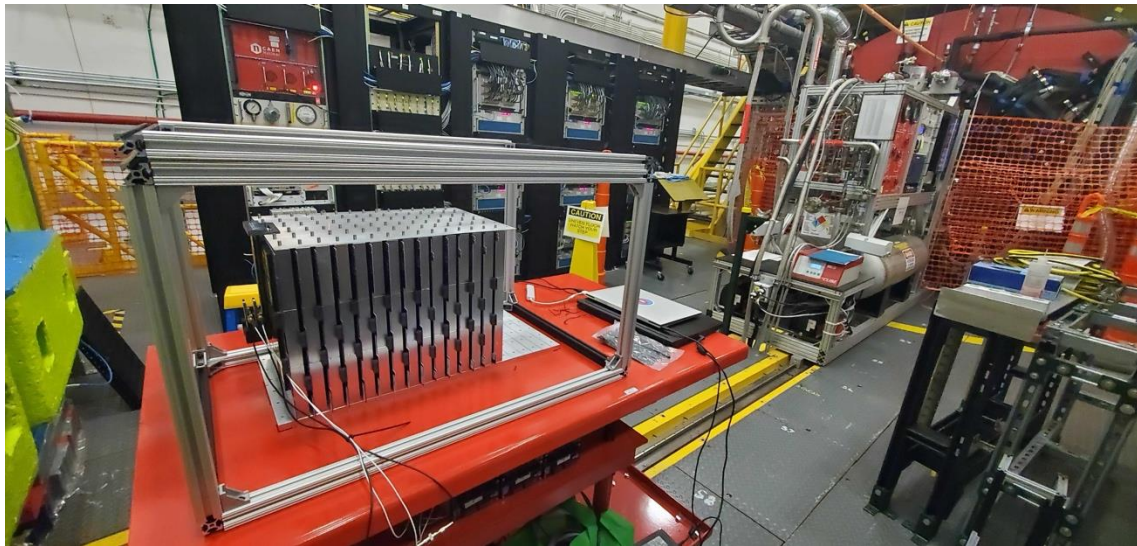

# Generation III Engineering Test Module (JLab)

- Measured EM response and compared to simulation, energy and position resolution
- Differences may be attributed to detector effects not included in simulation (electrical cross-talk, non-ideal equalization)
- Design, QA procedures, and operation were refined for the final ZDC design

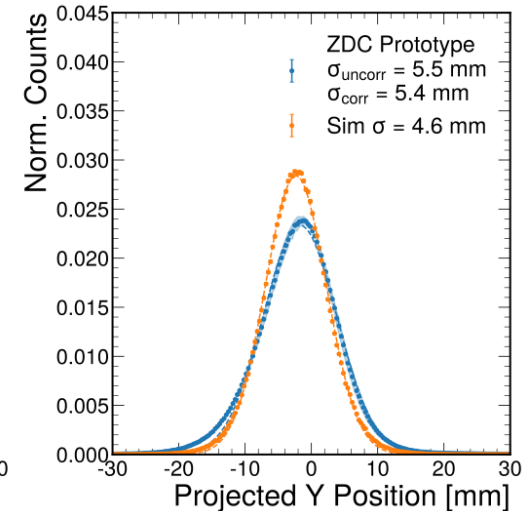
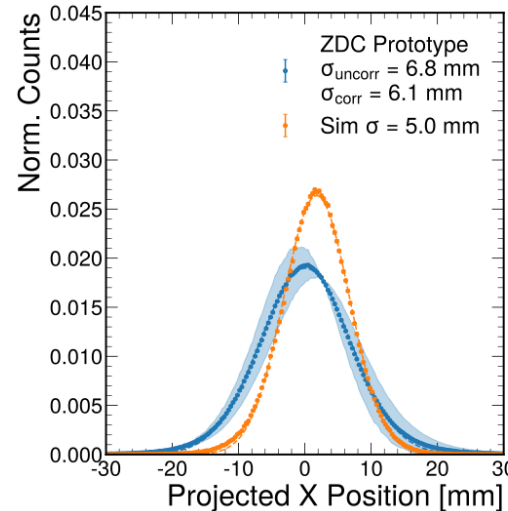
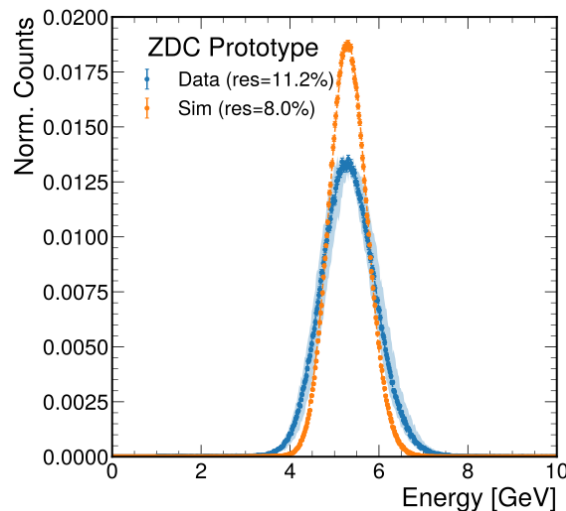

S. Preins, W. Zhang, R. Tsiao, M. Macias, B. Saunders, L. Preet, and M. Arratia, "Beam test of a sipm-on-tile zdc prototype with 5.3 gev positrons at Jefferson laboratory," [arXiv:2603.14167 \[phys.ins-det\]](https://arxiv.org/abs/2603.14167).

# Generation III Engineering Test Module (NSRL)

- At NSRL, the detector was exposed to up to  $10^{10.8} \frac{1\text{-MeV } n_{eq}}{\text{cm}^2}$ , exceeding the expected radiation fluence for the ZDC after 1 year of operation at the EIC
- The MIP signal-to-noise ratio reduced from  $\sim 60$  to  $\sim 5$ , but MIP calibration could still be performed.

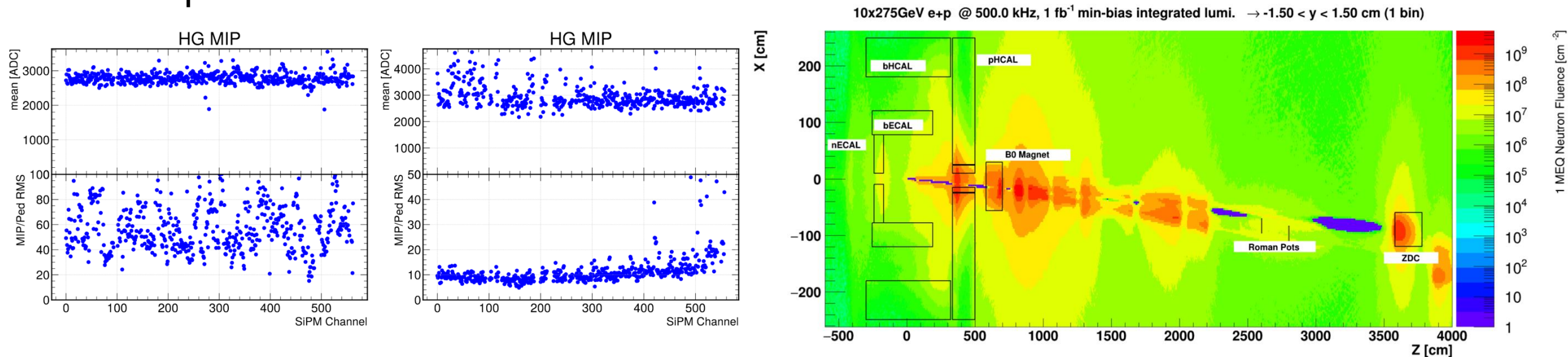
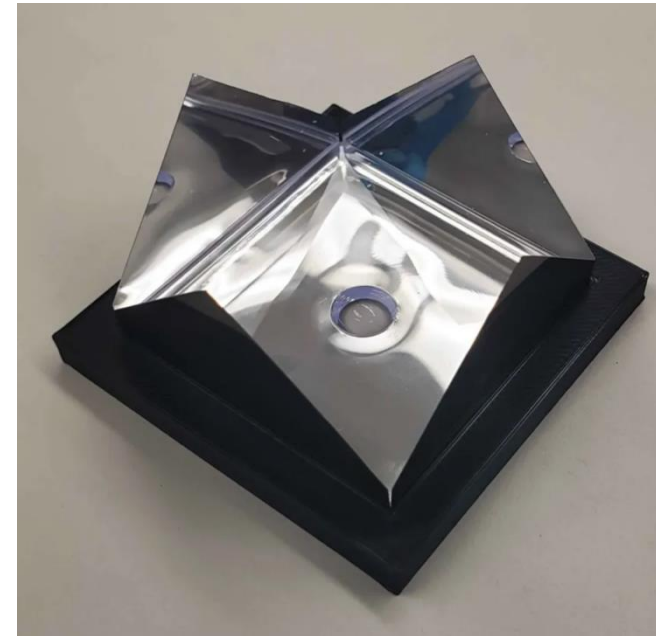

**Figure 8.** MIP calibration results for all channels before (left) and after (right) irradiation.

W. Zhang, X. Liang, S. Preins, and M. Arratia, “Calibration of an Irradiated Prototype for the EIC Zero-Degree Calorimeter,” [arXiv:2512.20852 \[physics.ins-det\]](https://arxiv.org/abs/2512.20852). Accepted in JINST.

# Construction, QA, and Assembly: Foils

- ESR foil sheets are cut for individual tiles using a 400 cm x 400 cm CNC 500 mW laser cutter, able to cut for 16 tiles at a time
- Foils are folded around tiles using a 3D-printed frame, and secured with a sticker



# Construction, QA, and Assembly: Layers (SiPMs)

- PCB is first tested for continuity with a multimeter
- Solder SiPMs and card connectors to pad locations with solder paste + stencil using an IR oven / hot plate
- Perform an IV scan on each channel using a Keithley 2450 unit
- Perform a short cosmic ray test with tiles placed on board, but not affixed

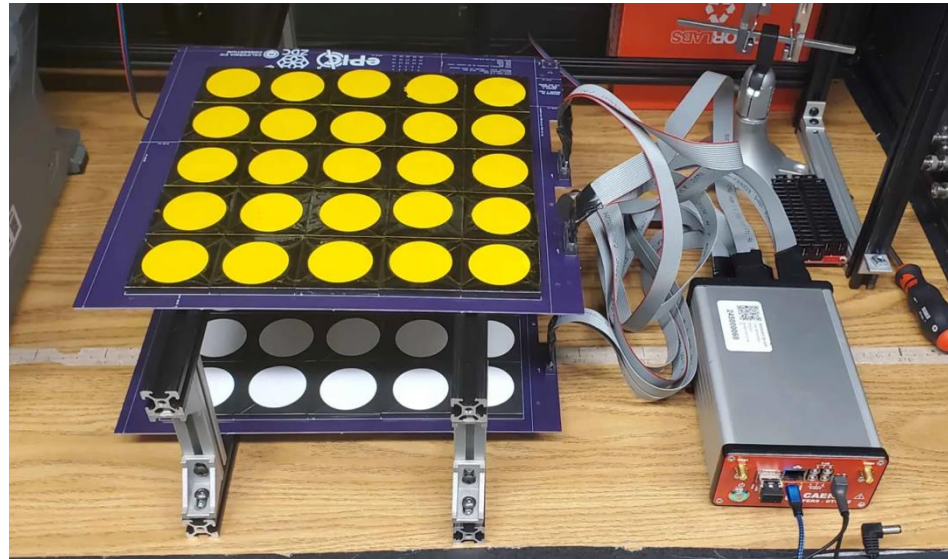

# Construction, QA, and Assembly: Layers (Tiles)

---

- Place tiles on the board and align them to the printed grid, and use masking tape to hold them in place relative to each other
- Fold a row of tiles down, and affix them to the board with double-sided tape
- Place a sheet of polyimide film on the front and back as a protective coating

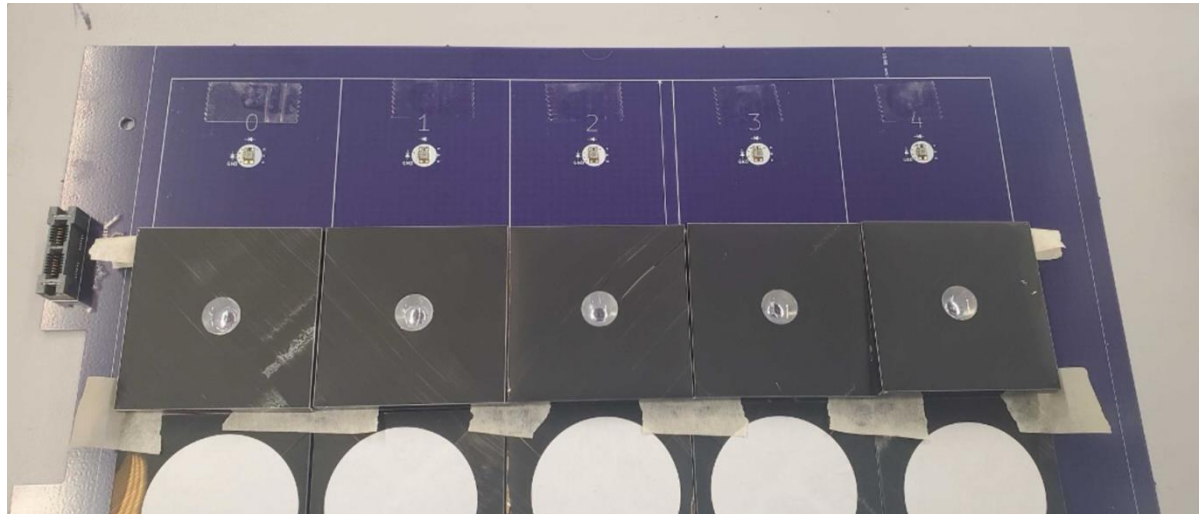

# Construction, QA, and Assembly: Cables and Iron

- 28 AWG shielded ribbon cables are soldered to custom edge card connector PCBs, tested via multimeter
- Iron layers consist of blocks recycled from the STAR FMS
- Iron is stacked together like LEGO blocks, and active layers can be slid in after construction

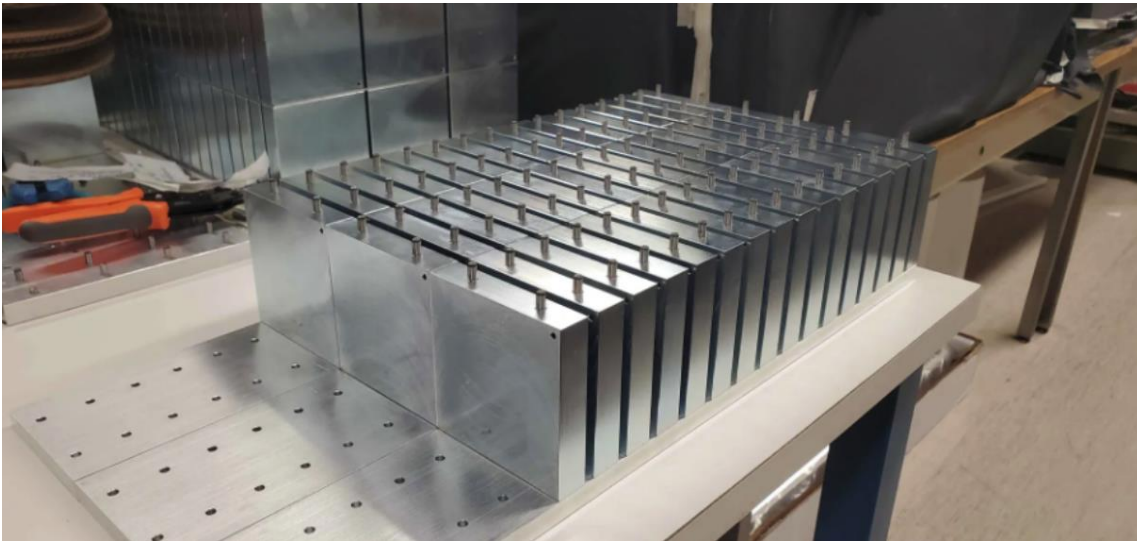

# Time Estimates

126.5 ch/layer  
64 layers  
192 boards  
8096 channels

Assembly/QA Step	Time	Total time
SiPM Solder	1 min/ch	135 h
Reflow	10 min/board	32 h
IV scan	30 s/ch + 4 min/board	80 h
Cable making	130 s/ch	290 h
Cosmic QA	10 min/board	3.5 h
Foil	5 min/ch	675 h
Iron assembly	10 layers/hour	6.5 h
Contingency/Troubleshooting	20%	248 h
	Total	1488 h

# Summary and To-Do

---

## Summary

- The ZDC HCAL has reached a stage of development nearing completeness for the final design
- Simulation studies demonstrate that the final ZDC design is likely to achieve the technical performance requirements outlined in the EIC Yellow Report
- Performance studies have informed the design, fabrication methods, QA tests, and operation of the ZDC

## To-Do

- Perform a GNN reconstruction on the updated square tile ZDC design
- Design final printed circuit boards