

H2GCROC readout for KEK beam test

Bo Gyeong SEO, Jun Seop SHIN, Shin Hyung KIM

Department of Physics, Kyungpook National University

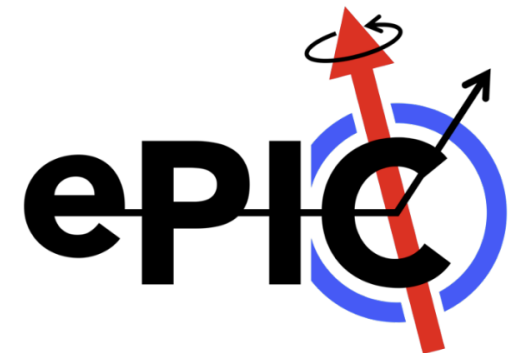

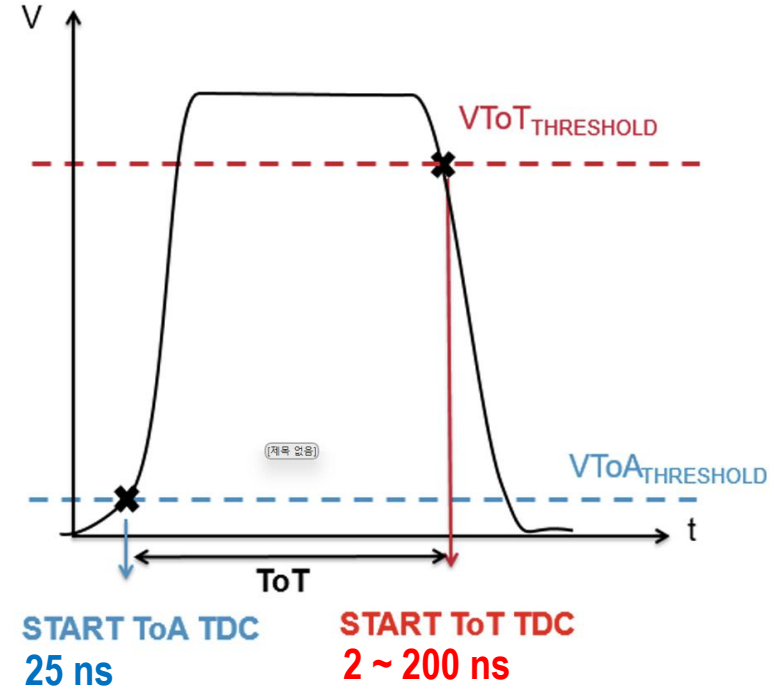
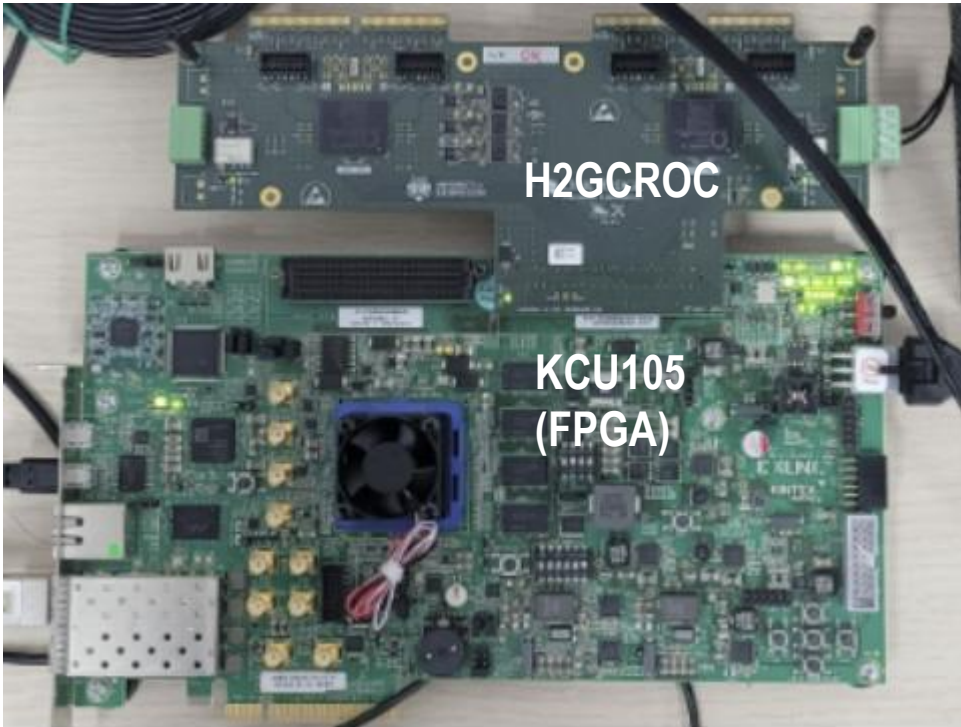

- ToT : 2 ~ 200ns
- Maria suggestion (Ideal) :
 Rising < ~ 20 ns (time difference of each end)
 Falling < ~70 ns (beam bunch crossing)
- Dynamic range : 160 fC – 320 pC

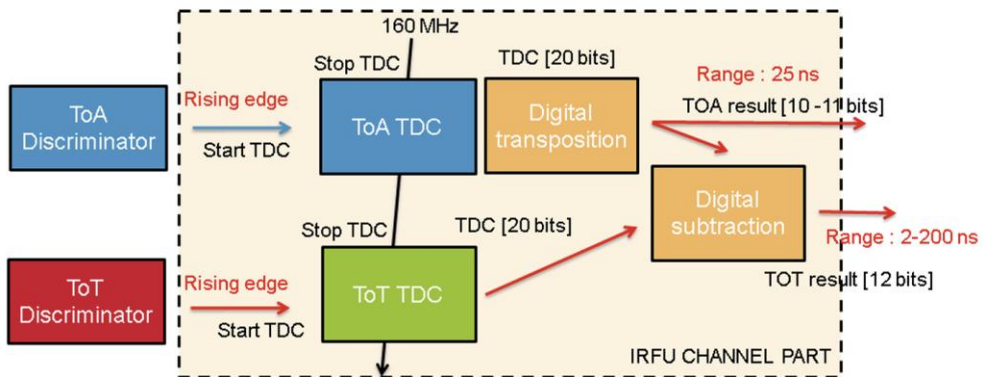

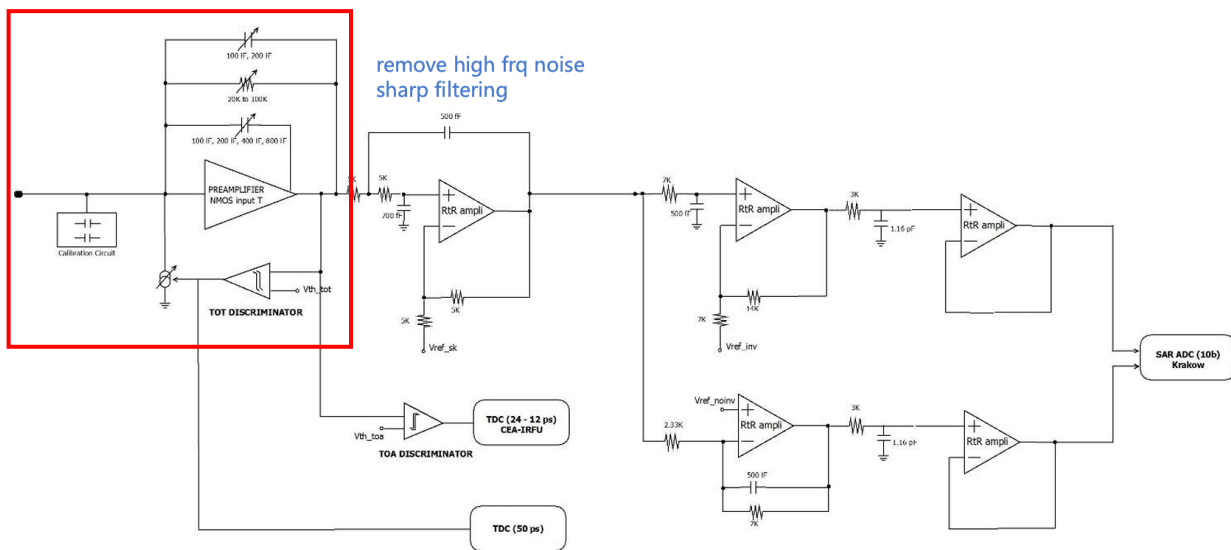

C_d (pF)	5, 10, 20	At the conveyor output and at the preamplifier input. To ensure the preamp stability
R_f (Ohm)	10K, 20K, 40K, 80K	In parallel, these resistors provide 15 values to be adjusted with the C_f and C_{f_comp} values
C_f (fF)	50, 100, 200, 400	Added with the C_{f_comp} capacitors, provide the preamplifier constant time with R_f
C_{f_comp} (fF)	50, 100, 200, 400	Same purpose than C_f capacitors but connected differently to improve the preamplifier stability.

C_d (gain) : 0.2, 0.1, 0.5, 0.25

4bit, parallel connection

Summing	R_f	C_f	C_d	C_{f_comp}
All	0101	0100	1010	0001
Hybrid & Parallel	1111	0001	0001	1111
	0100	0001	0001	1111
Hybrid	1111	1111	0001	1111
	1111	0001	0100	1111
Indiv	1111	1111	0100	1111
	1111	0100	1111	1111
	0100	1111	1111	1111

Settings at 2605 TB, KEK



Dynamic range (Npe)

Measured Npe (2507 CERN TB) & expected current

	Mean Npe per SiPM (9 cm ²)			pC (4.5cm ²)	
e- (GeV)	1st	2nd	3rd	3rd	LED V
0.5	600	1100	700	280	
1	700	1800	1500	600	
2	1000	2800	3000	1200	1.79
3	1100	3800	4500	1800	
4	1150	4500	6000	2400	1.83
5	1300	5500	7500	3200	

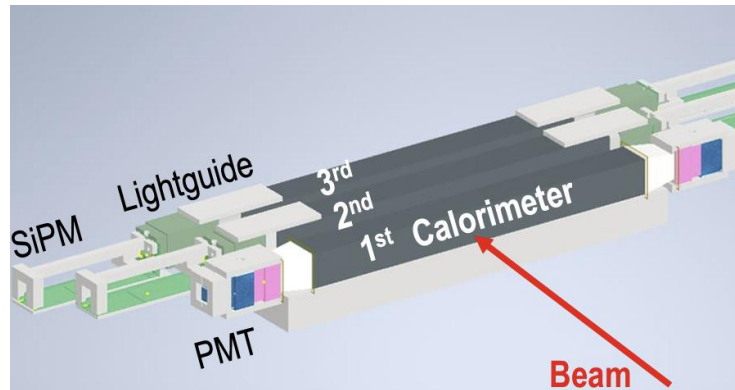

→ **Attenuation needed!**
Or lower HV...

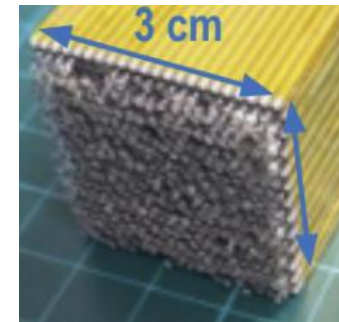

Area : 9 cm²

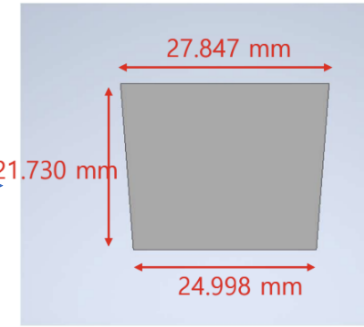

Area : ~4.5 cm²

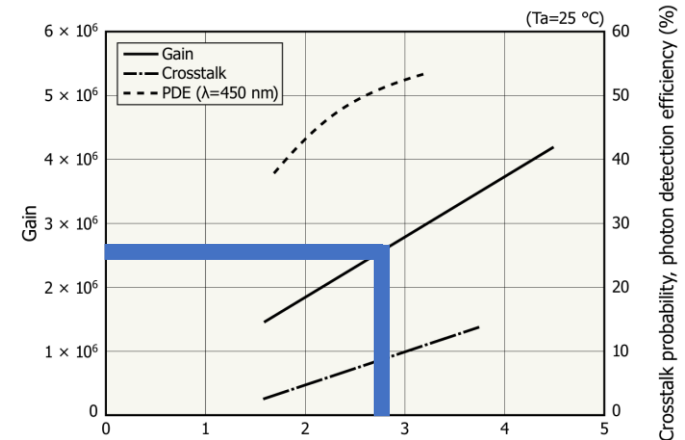

S14, 40.7 V :
Spe current ≈ 0.4 pC



Hybrid, 1st, default

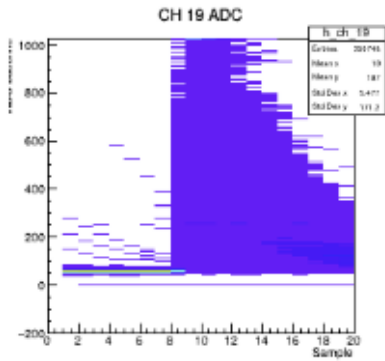

2 GeV

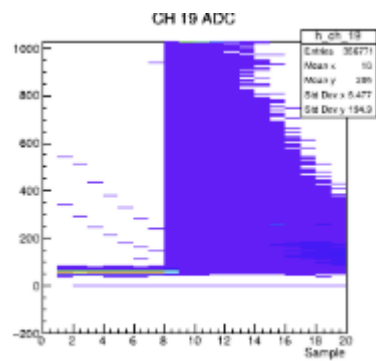

3 GeV

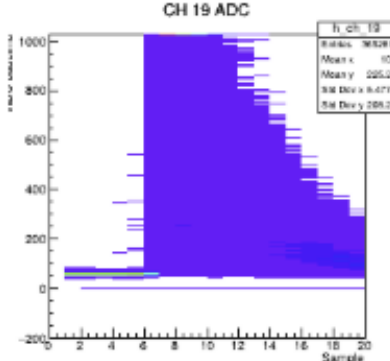

4 GeV

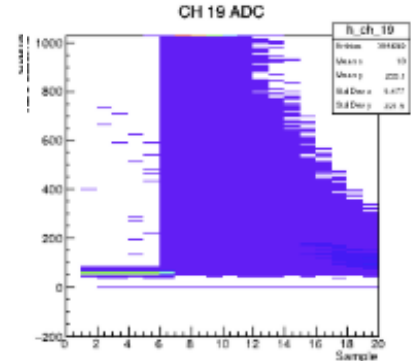

5 GeV

Hybrid, 1st, 3GeV

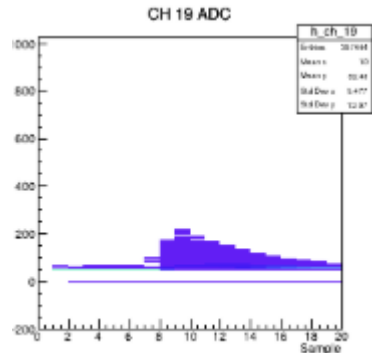

15-1-1-15

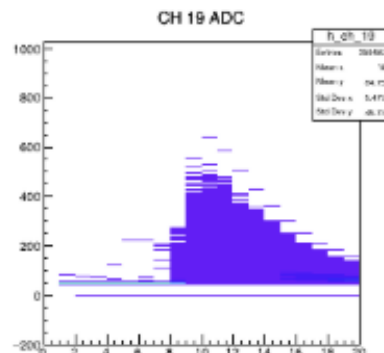

4-1-1-15

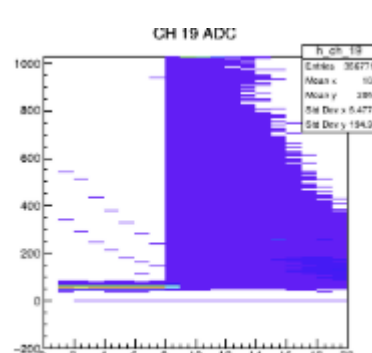

5-4-10-1 (default)



Delay scan (parallel, 4ch sum)

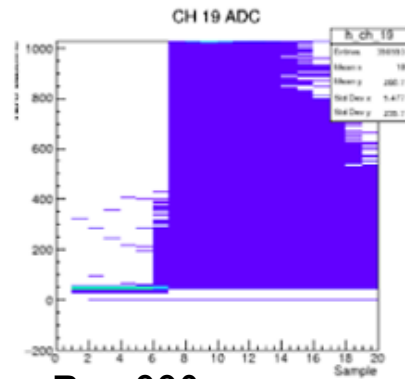

Run 330

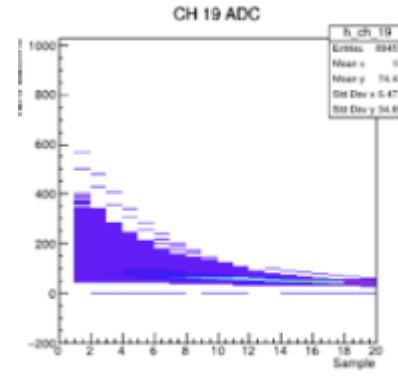

Run 331 (delay 20 from Run 330)

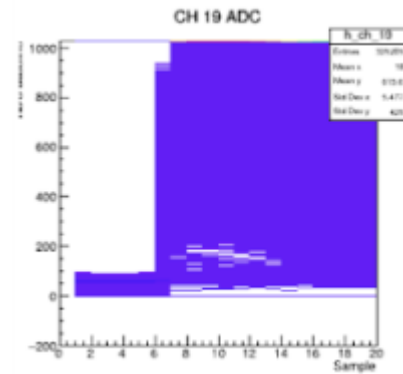

Run 332

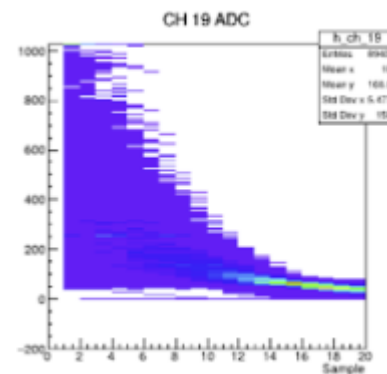

Run 333 (delay 20 from Run 330)

Parallel : width too wide. Both ADC and TOT saturated
→ did a delay scan to find width manually



- 1GeV, 3rd
 - 3cm x 3cm x 32cm Calorimeter
 - 5cm length Lightguide
 - Mean Edep : 208 MeV (simulated)
 - Mean Npe : 1500 photons (25TB CERN)
- HV : 43 V
- Preamp : default
- No Cable : minimum attenuation

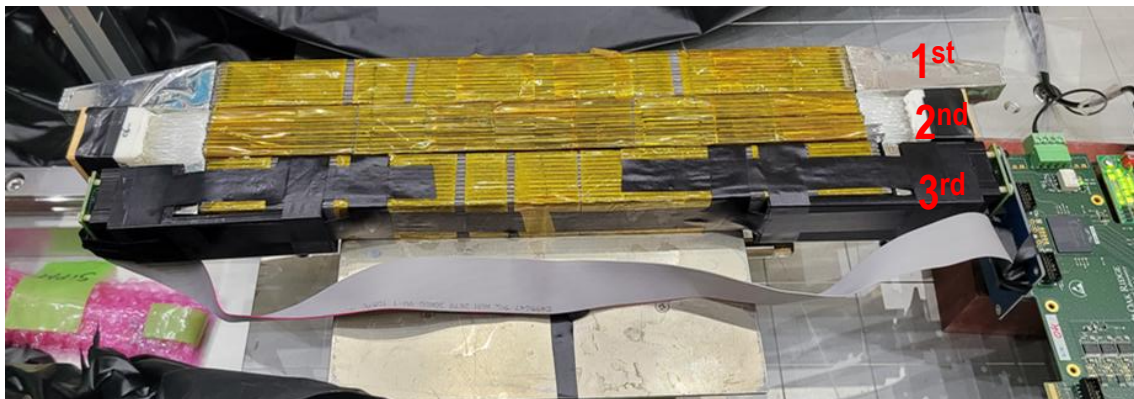

No cable (board directly in contact with H2GCROC)
Samtec loose : no signal

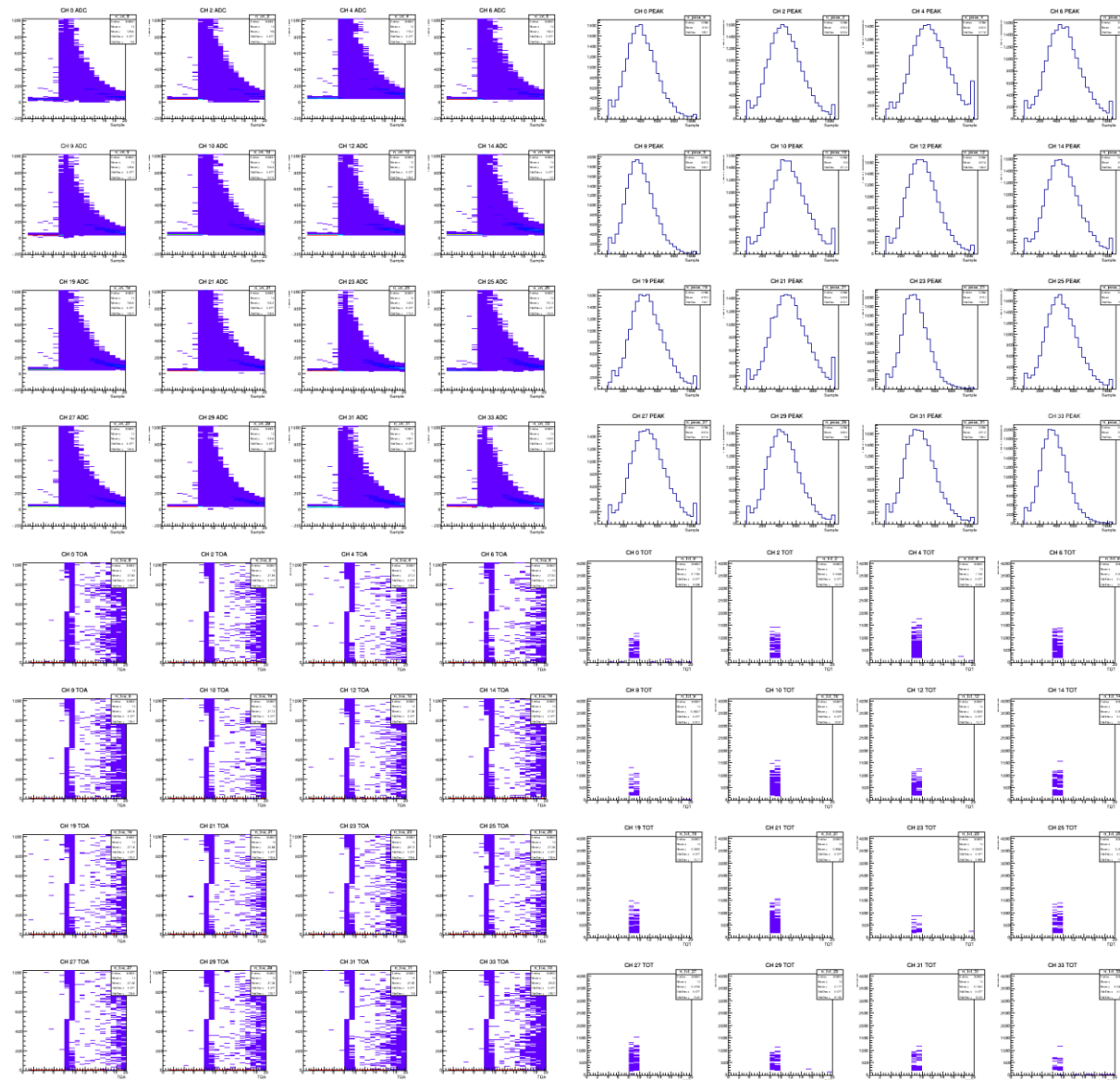



Hybrid summing

- 1GeV, 3rd
- HV : 16 array each (Notice HV module, 40.5 ~ 41 V)
- Preamp : default
- Hybrid sum → Op Amp → H2GCROC

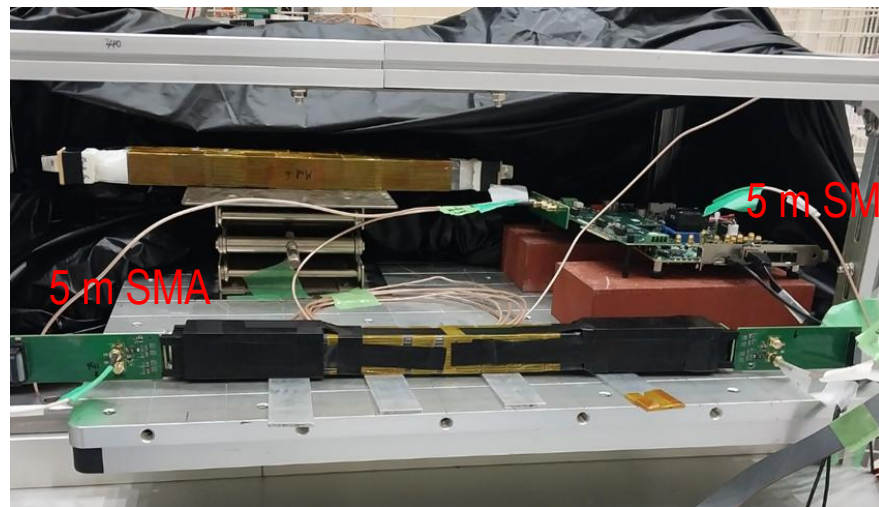
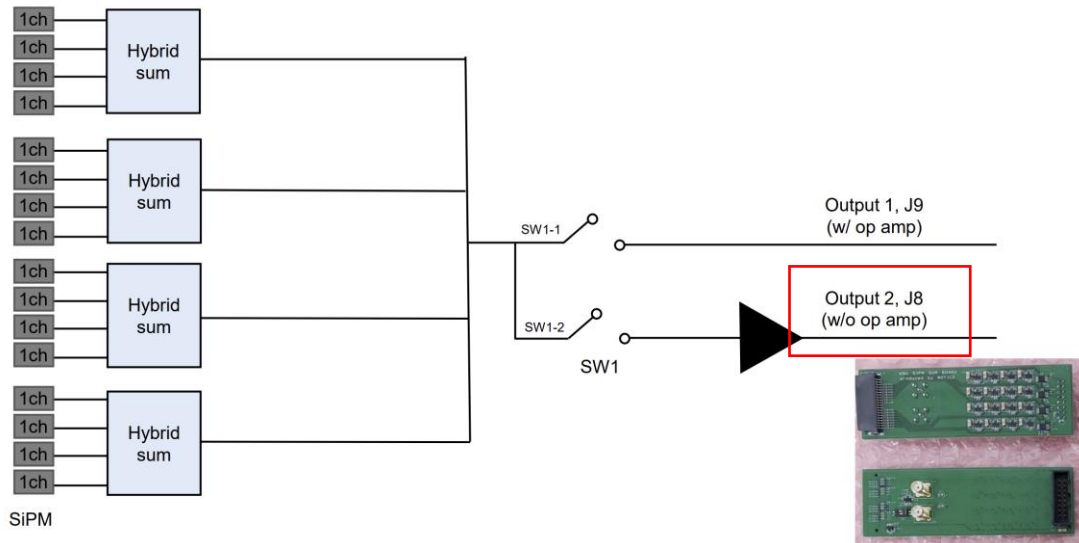
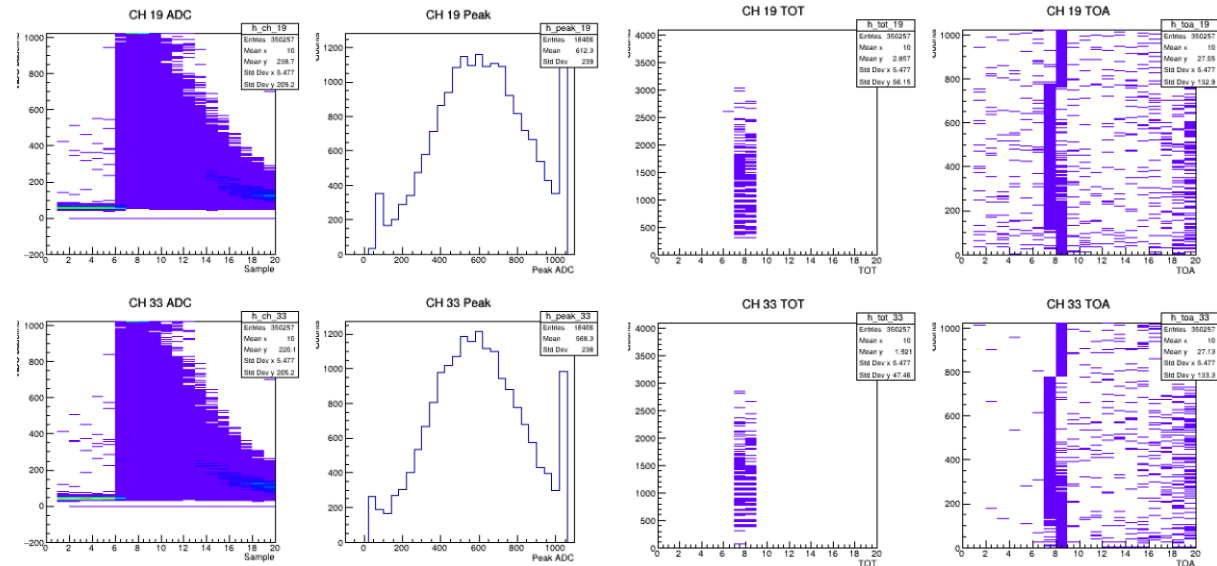

Signal : 5 m SMA cable, cable attenuation

Parallel summing

- 1GeV, 3rd
- HV : 16 array each (Notice HV module, 40.5 ~ 41 V)
- Preamp : default
- Parallel sum \rightarrow Op Amp \rightarrow H2GCROC

Parallel (3 output)

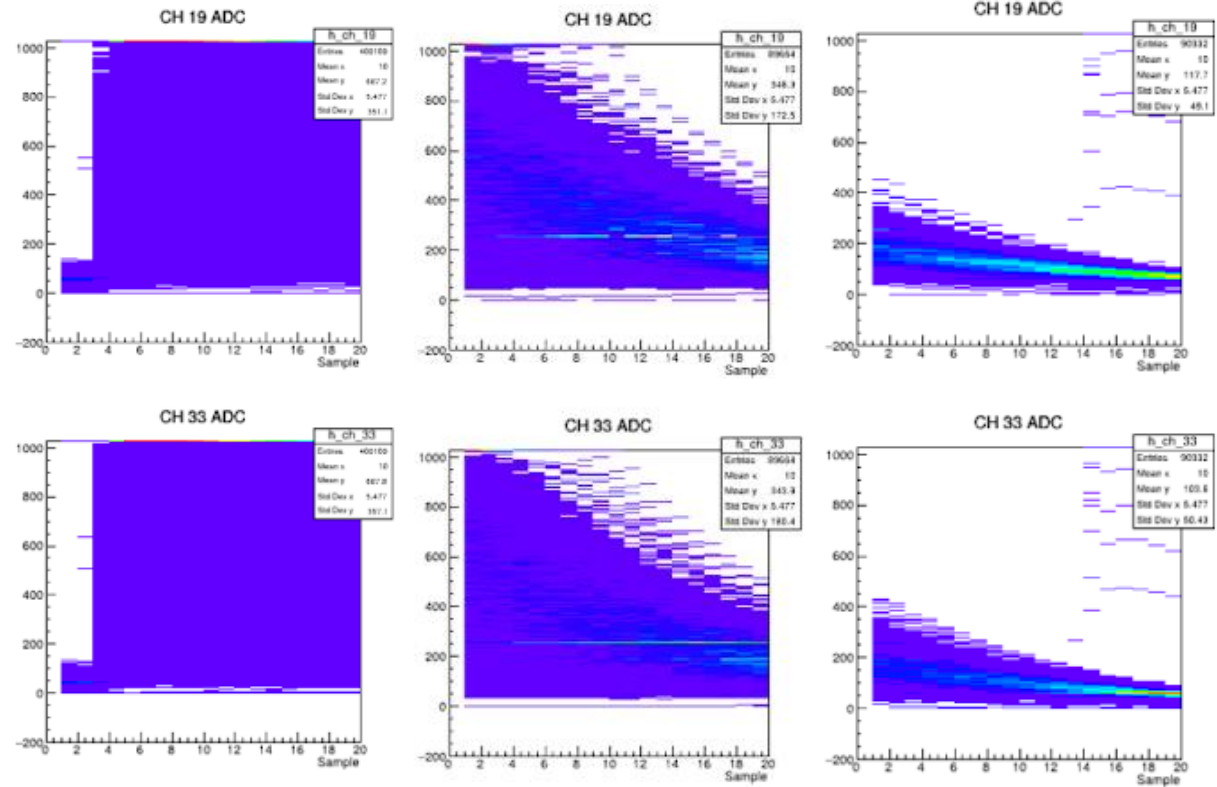
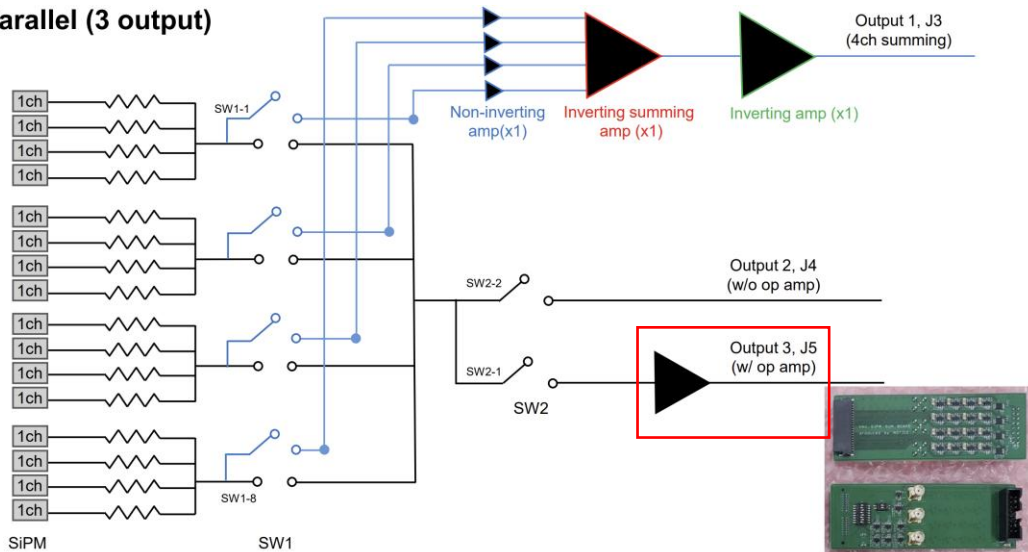

Delay 20 sample

Delay 20 sample



Parallel 4ch summing

- 1GeV, 3rd
- HV : 16 array each (Notice HV module, 40.5 ~ 41 V)
- Preamp : default
- Parallel 4ch sum \rightarrow Op Amp \rightarrow H2GCROC

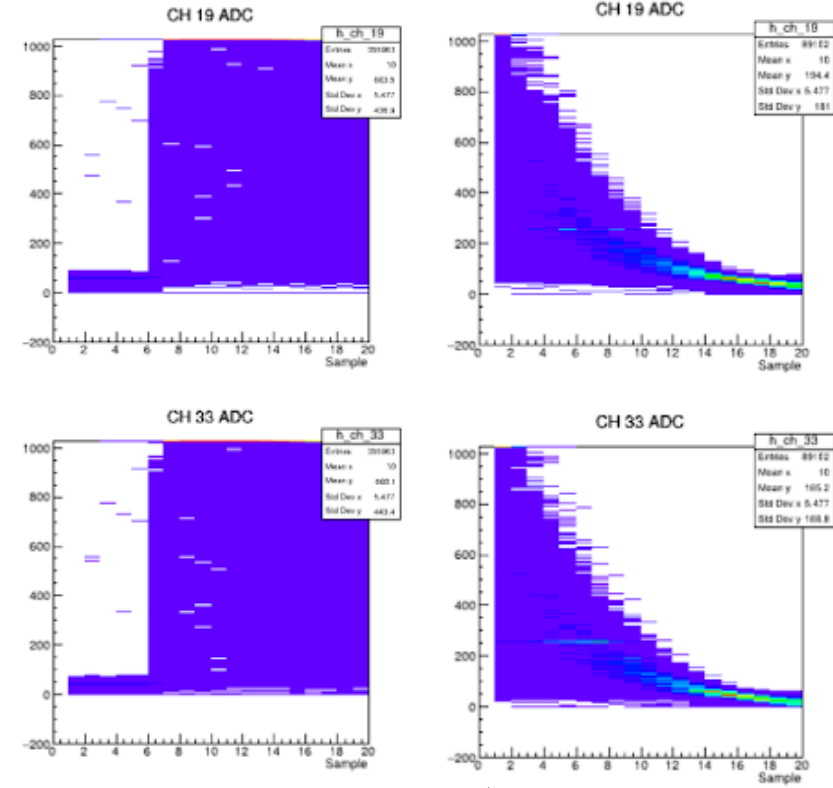

Parallel (3 output)

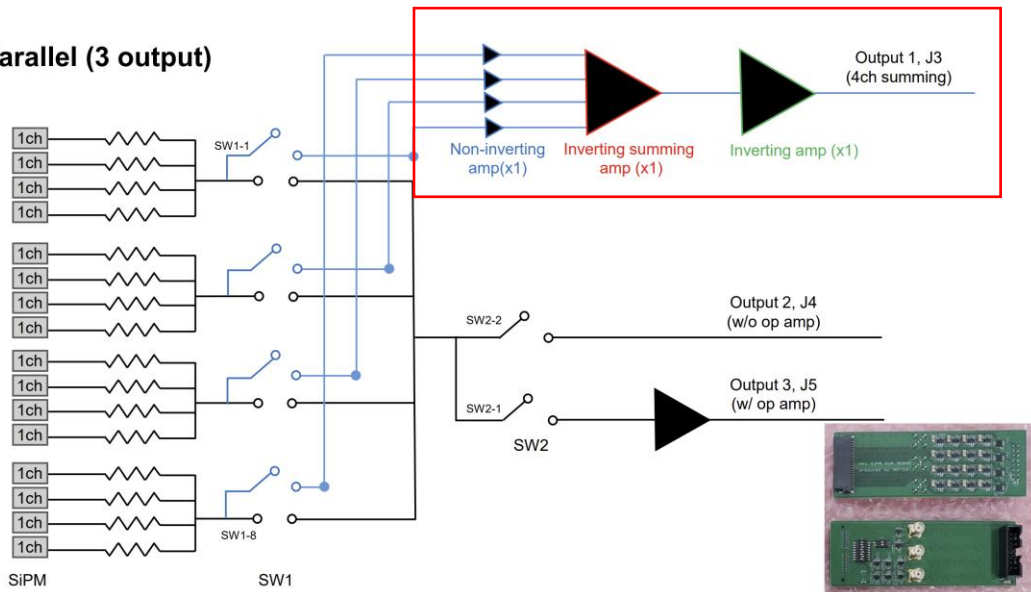

Delay 20 sample

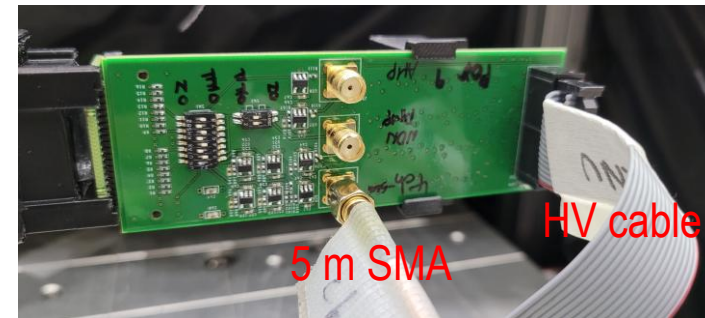



Cosmic ray : MIP

Beam 45

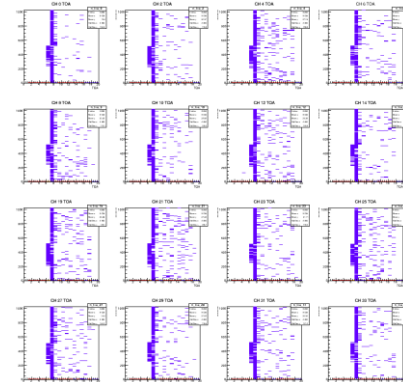
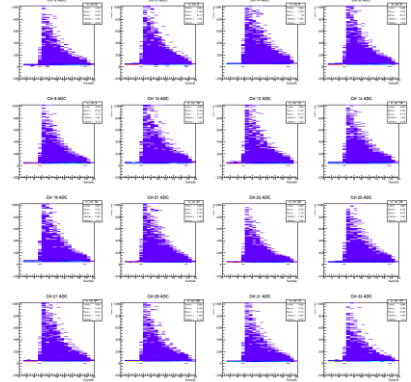
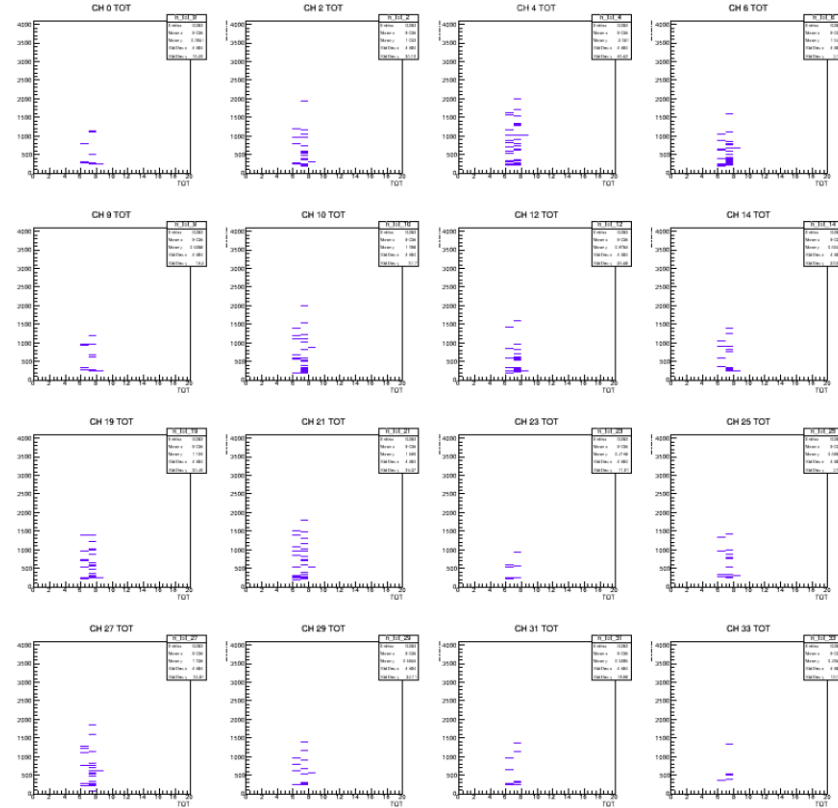
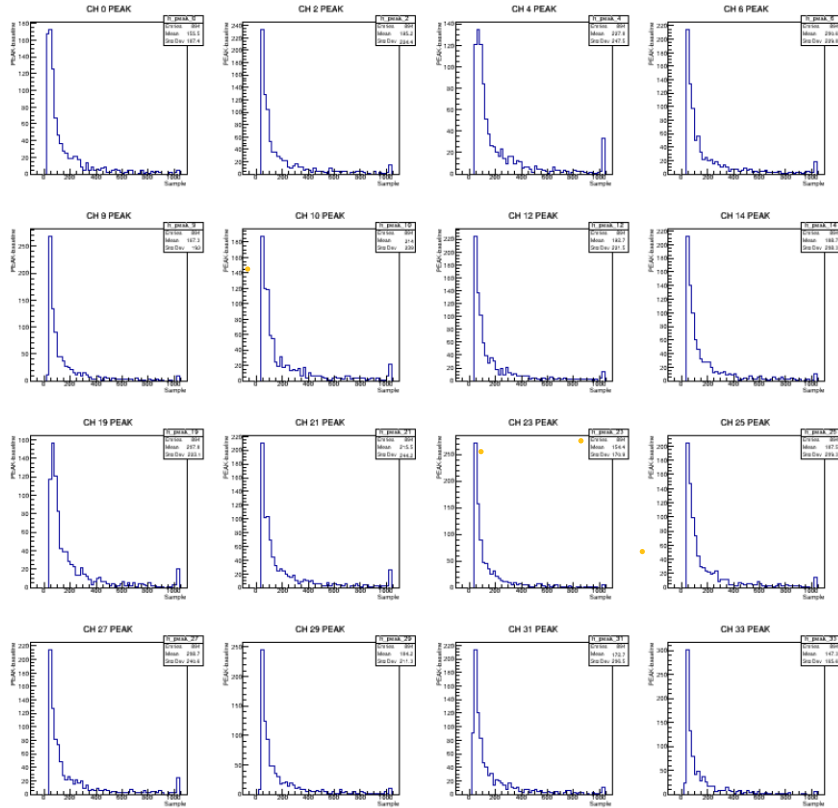

Preamp : Default



Cosmic ray : MIP

Beam 100, Hybrid summing

CH 19 ADC

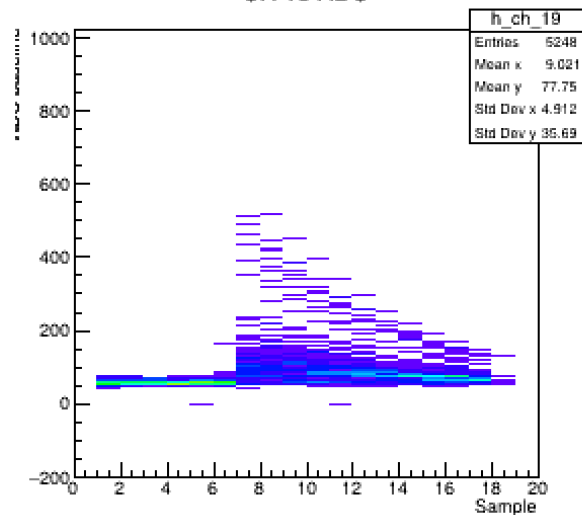

CH 19 Peak

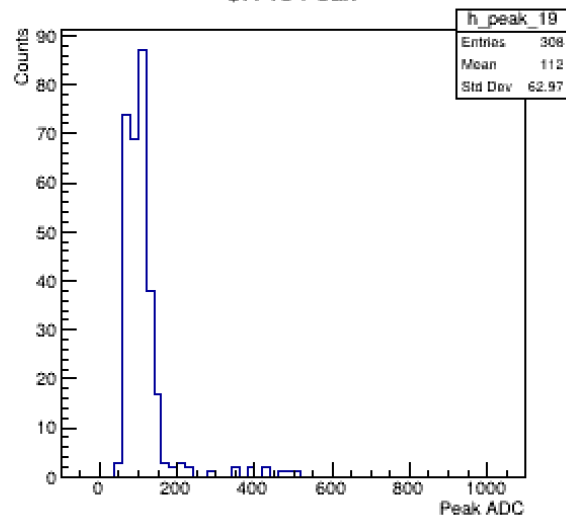

CH 19 TOT

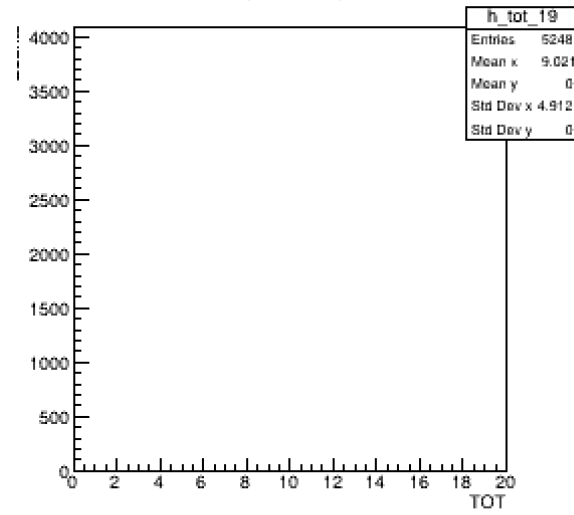

CH 19 TOA

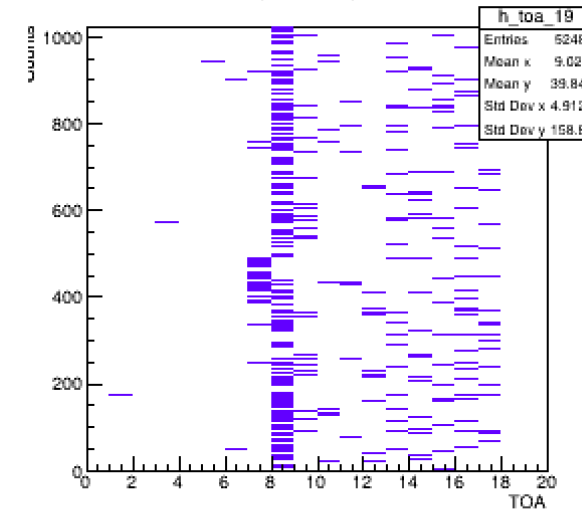

CH 33 ADC

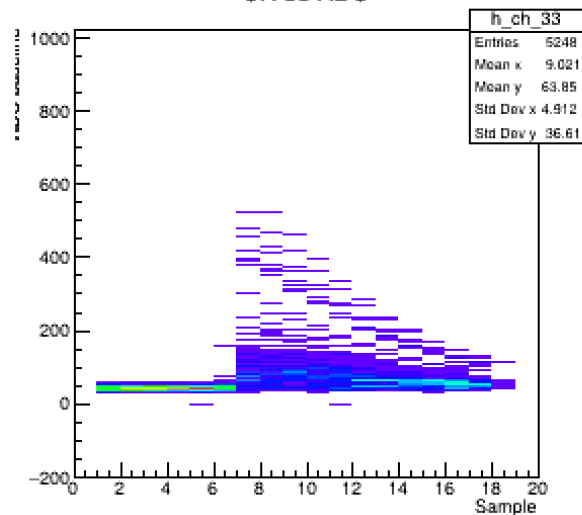

CH 33 Peak

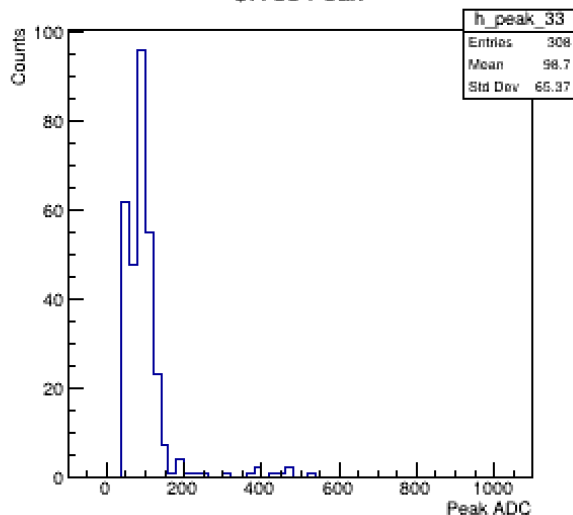

CH 33 TOT

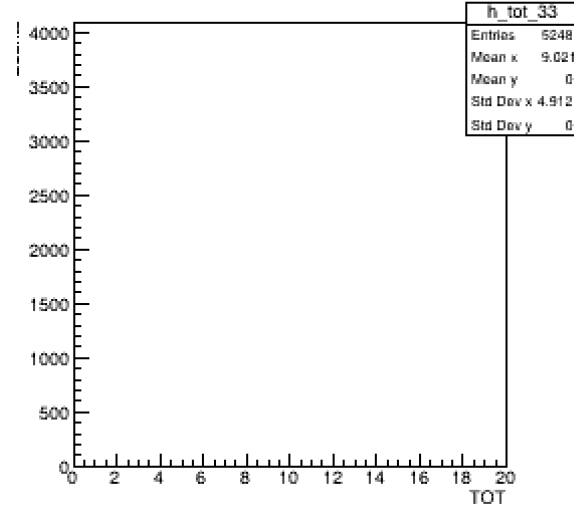

CH 33 TOA

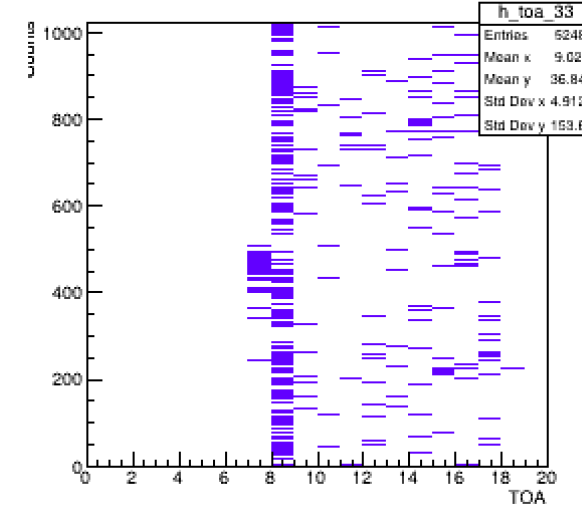



Cosmic ray : MIP

Beam 230, Parallel

CH 19 ADC

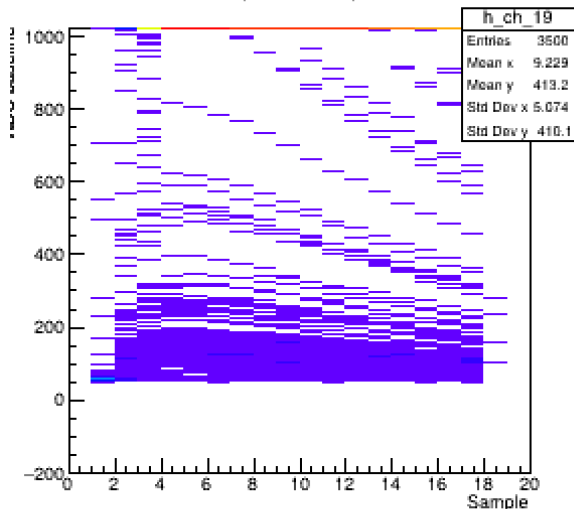

CH 19 Peak

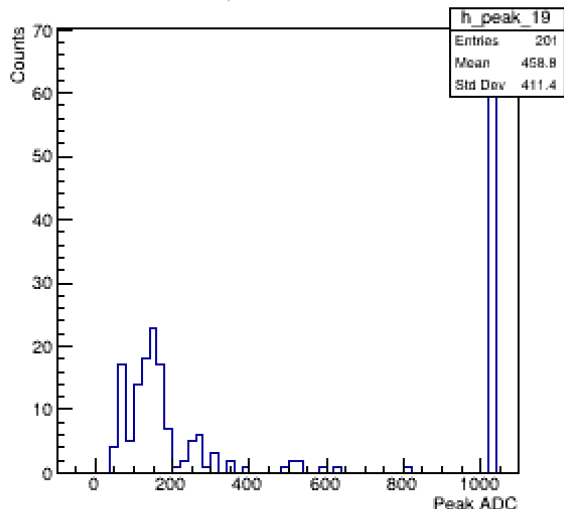

CH 19 TOT

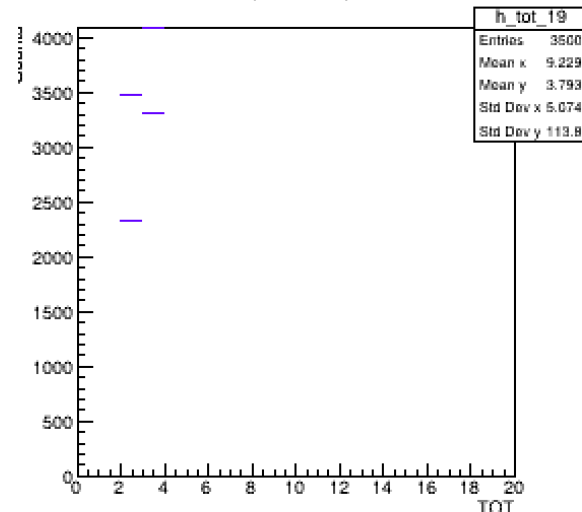

CH 19 TOA

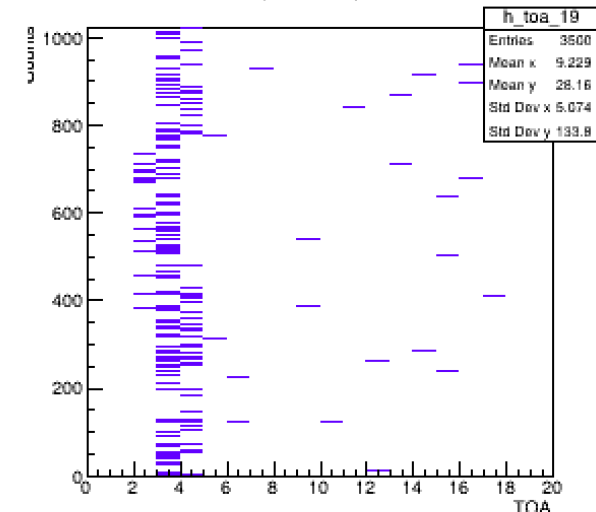

CH 33 ADC

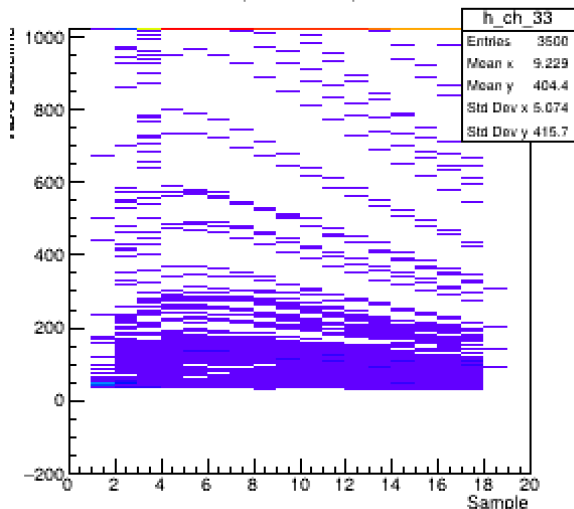

CH 33 Peak

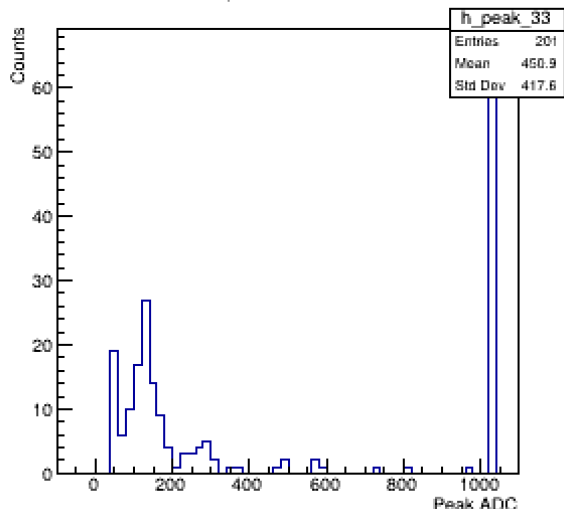

CH 33 TOT

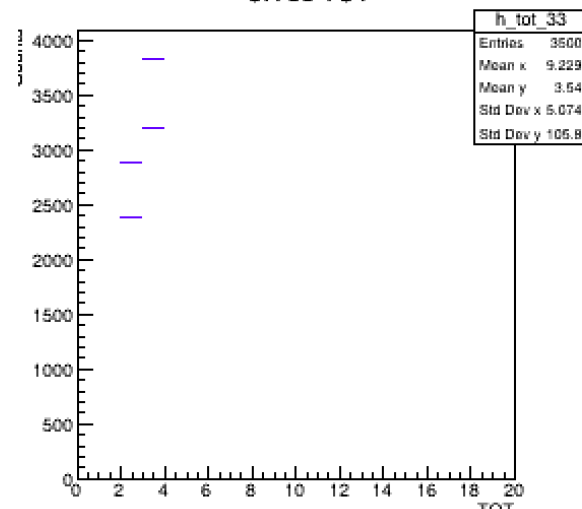

CH 33 TOA

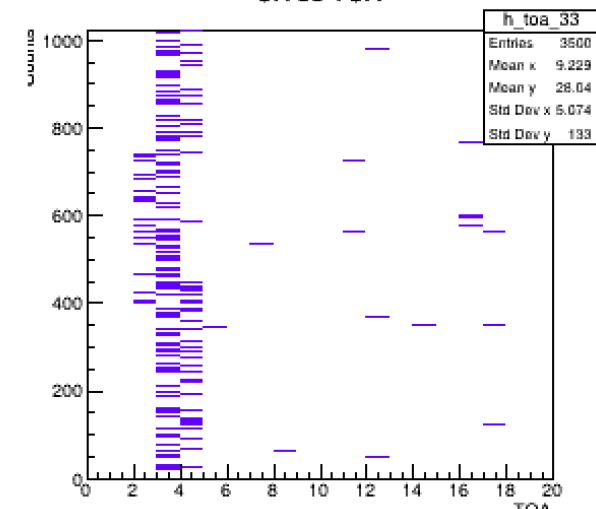



Cosmic ray : MIP

Beam 522, Parallel 4ch

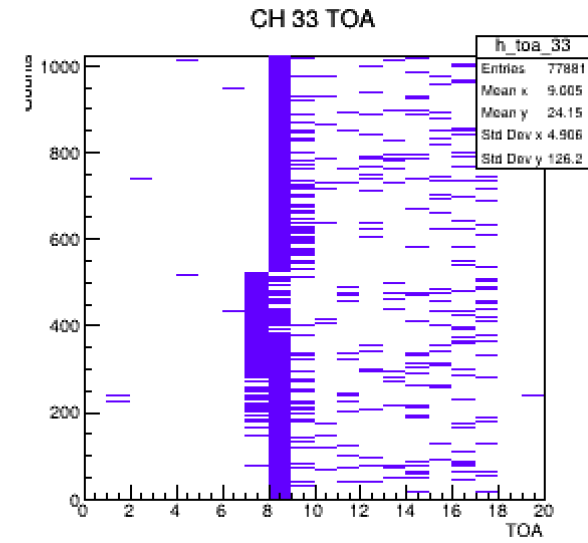
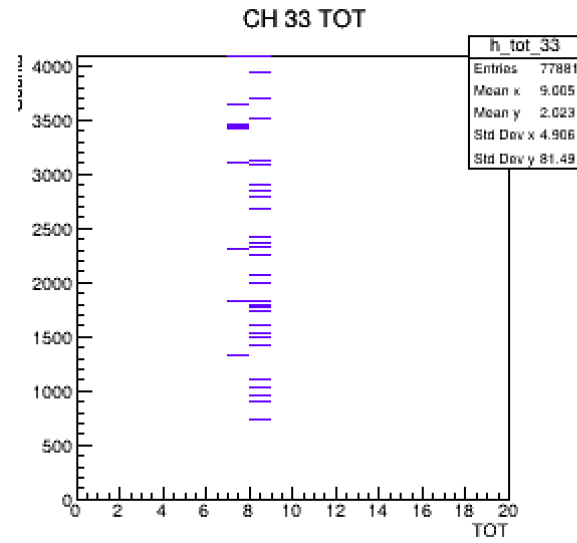
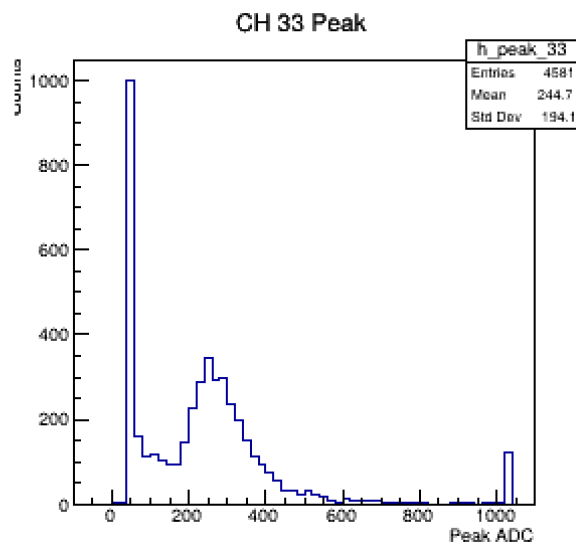
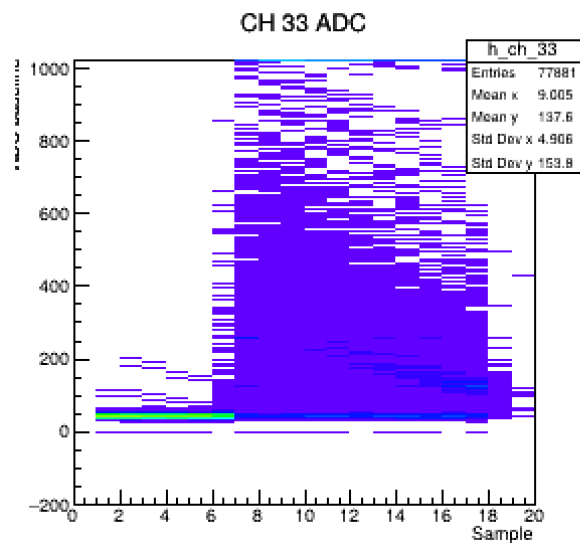
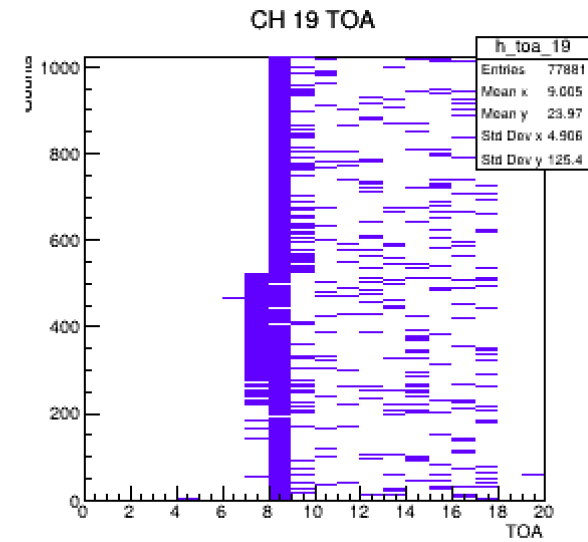
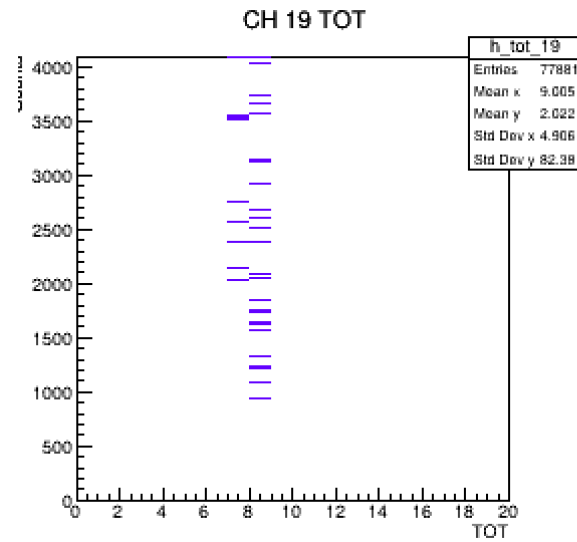
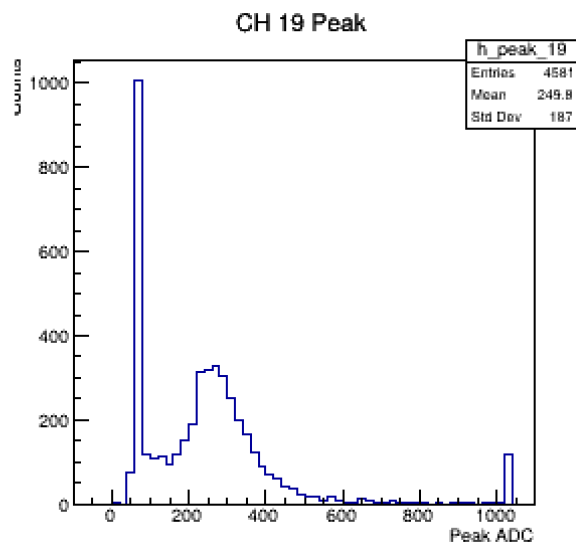
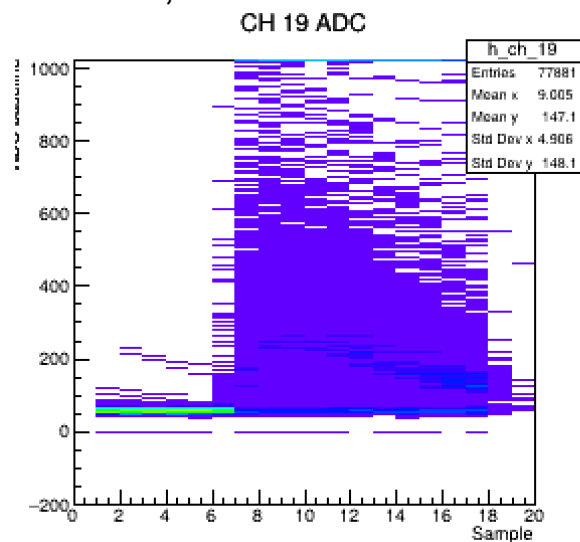



ADC – TOT equivalent

Beam 160

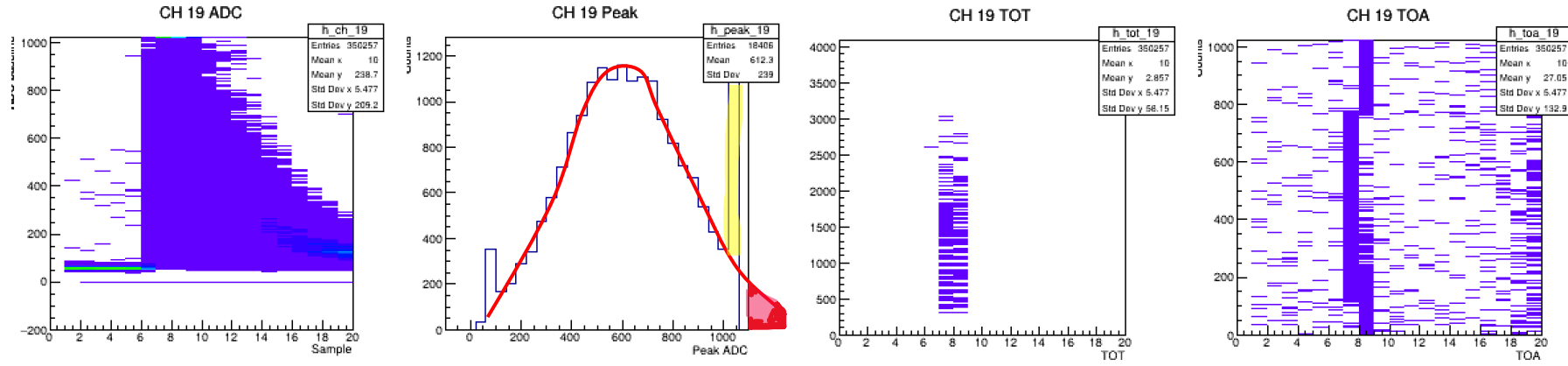

Beam 45

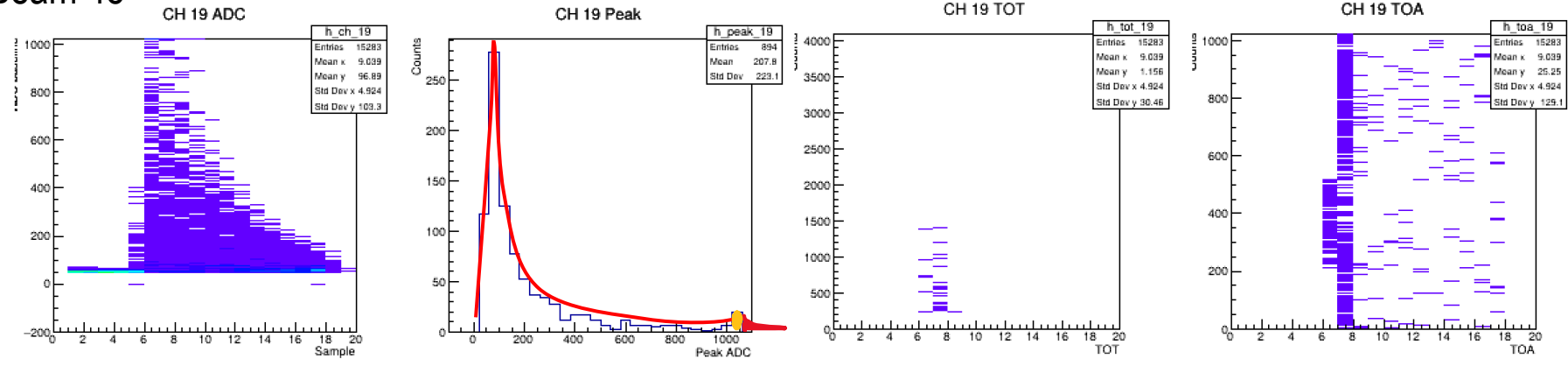

Get tail → Expect saturated ADC into ADC
 Compare with ToT value
 → ADC – ToT equivalent function?

Nominal

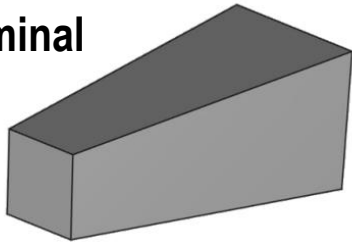

Hexagonal

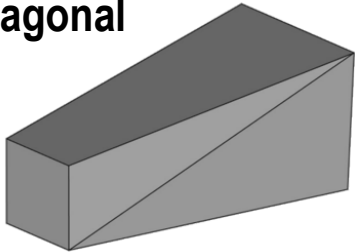

Trapezoidal

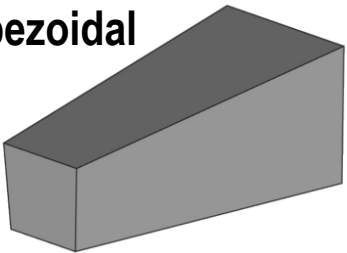

Side view

Layer 1

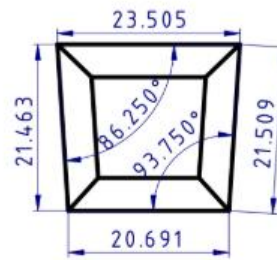
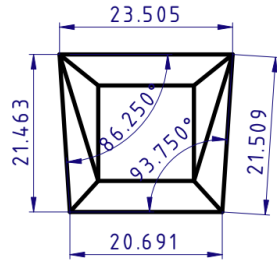
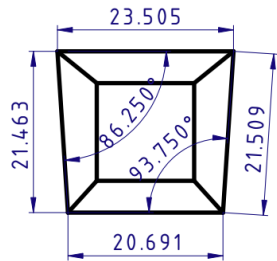

- Different light guide at each calorimeter end
- Wrapped with Al Mylar

Efficiency

- HV : calibrated
- Notice summing board : get summed signal

Light mixing

- HV : not calibrated
- Individual : get 16 array signal





Efficiency : BT and B

Run 523

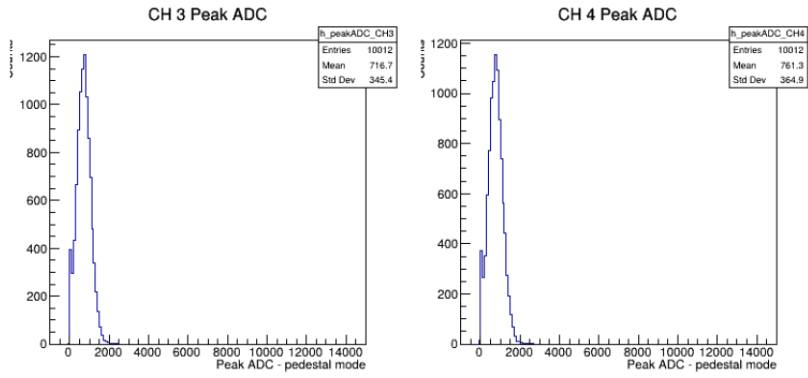

Run 524

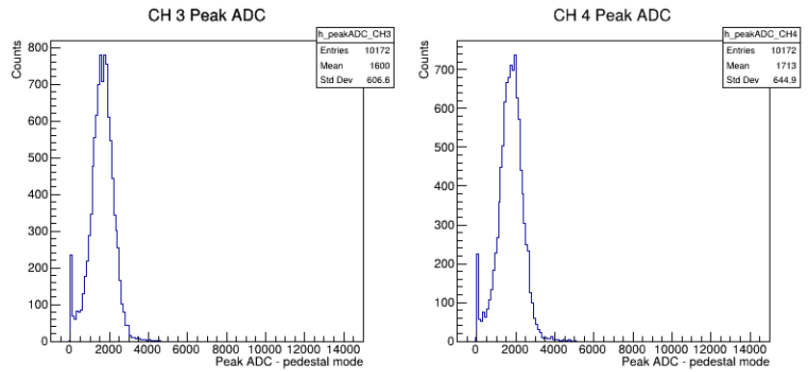

Run 525

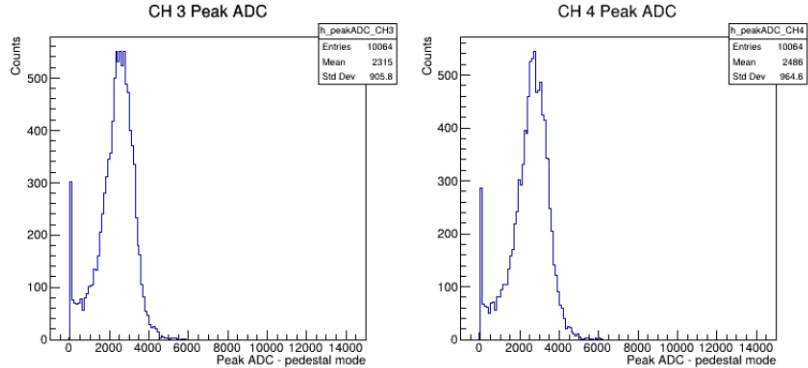

Run 526

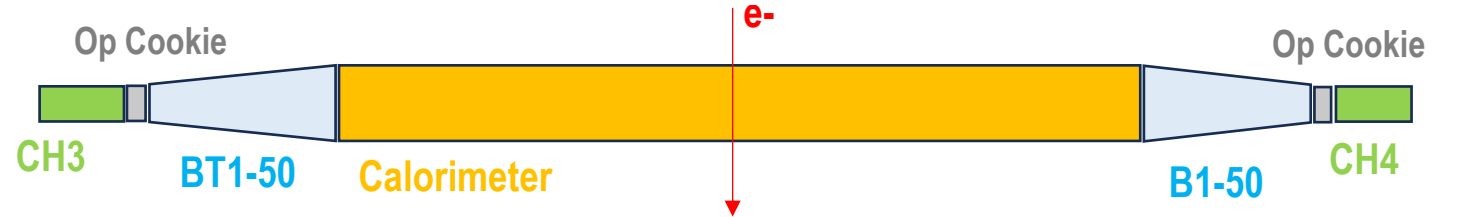
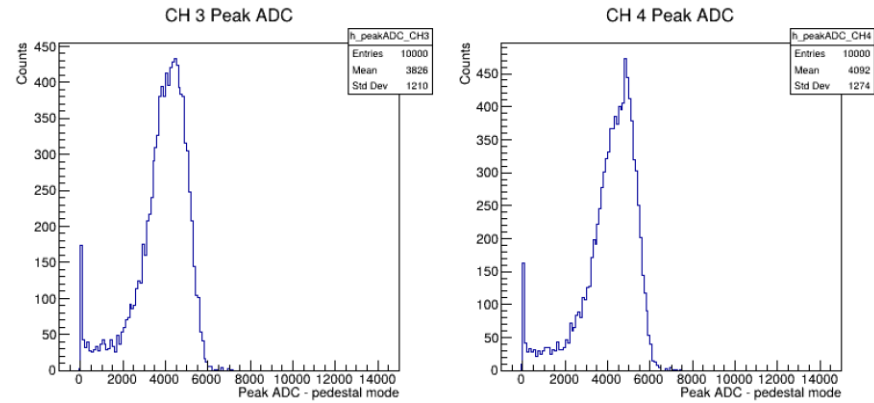

GeV/c	B	BH	BT	BT/B
1	762		716	0.940
2	1715		1601	0.936
3	2489		2318	0.931
5	4093		3827	0.935

Mean ADC



Efficiency : BH and B

Run 530

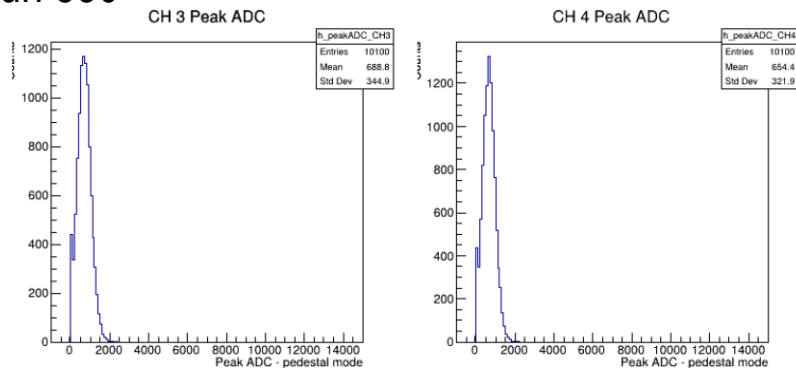

Run 527

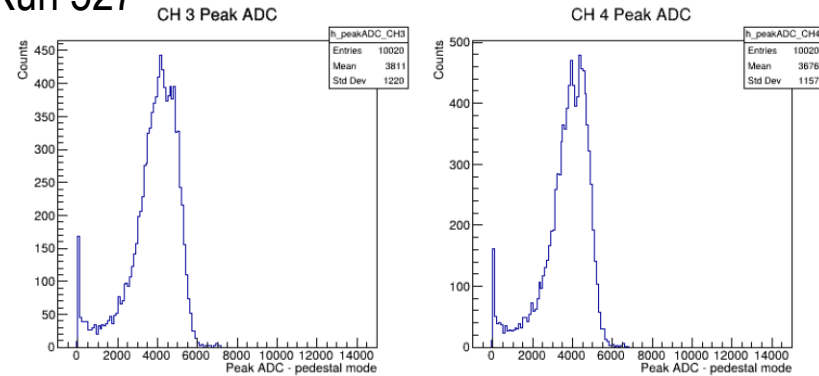

Run 529

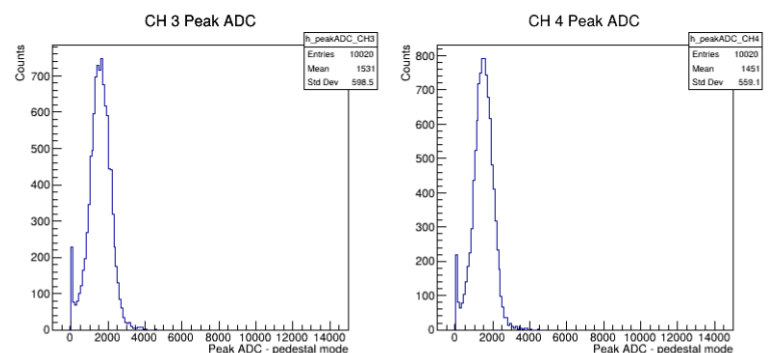

Run 528

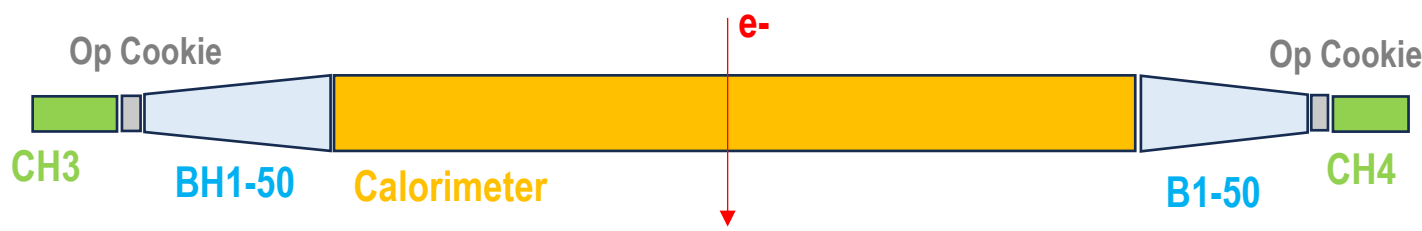
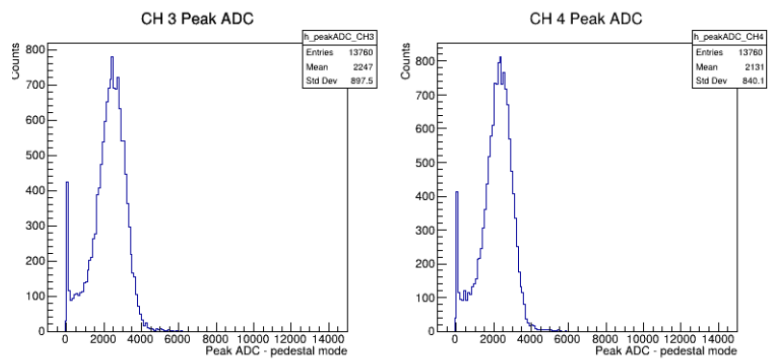

BT → BH
 B was not changed

GeV/c	B	BH	BT	BH/B
1	656	690		1.05
2	1453	1532		1.05
3	2134	2250		1.05
5	3877	3812		1.02

Mean ADC



- ADC – TOT equivalent function
- Signal **Landau fitting** with ADC, TOA and TOT
- See preamp & summing board difference, and decide which setup to use
- See linearity of each setup



Light guide dimension

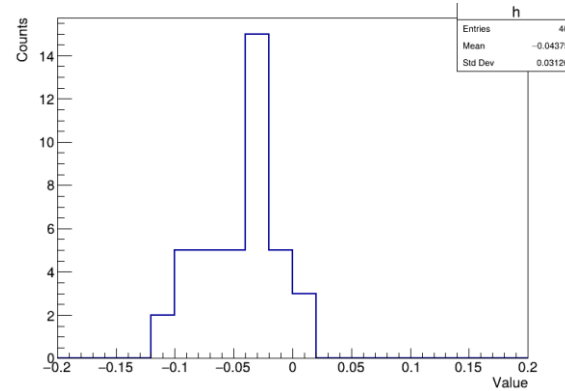
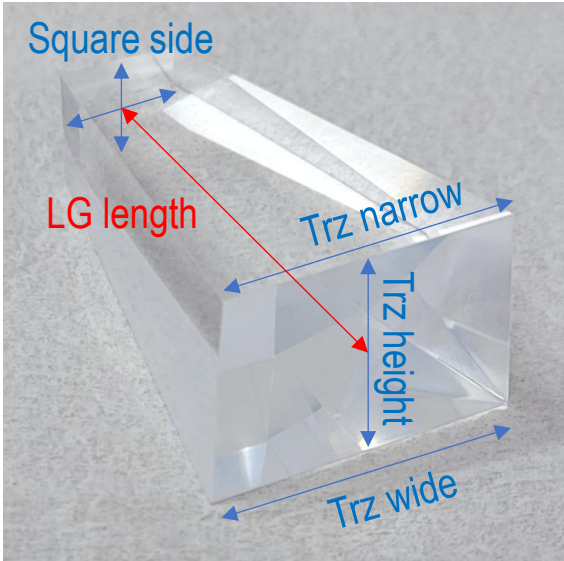

Trapezoid Wide side
 AVG : -0.044
 STD : 0.032

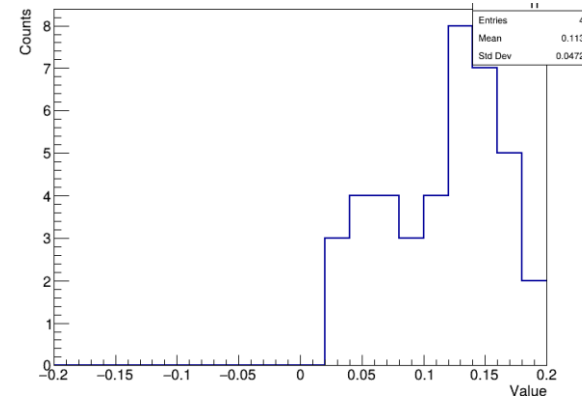

Trapezoid Narrow side
 AVG : 0.114
 STD : 0.047

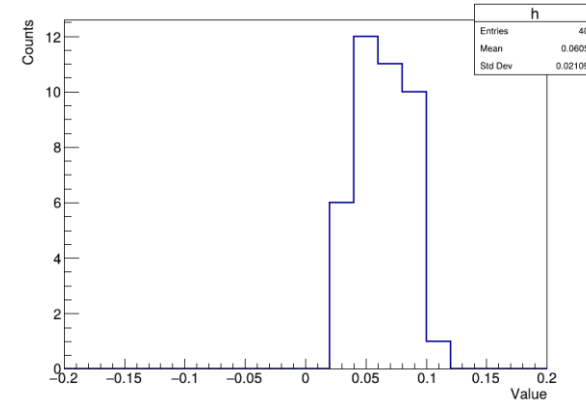

Trapezoid height
 AVG : 0.061
 STD : 0.021

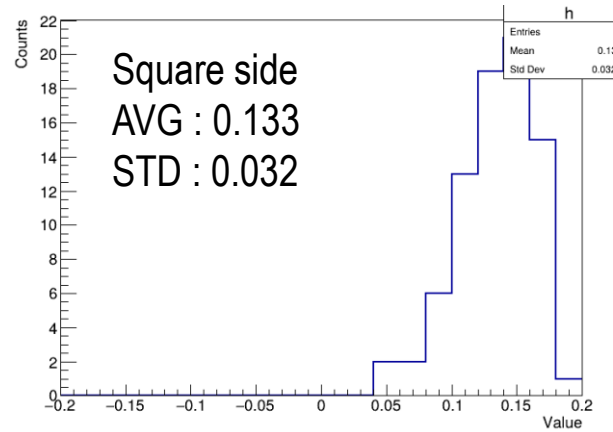

Square side
 AVG : 0.133
 STD : 0.032

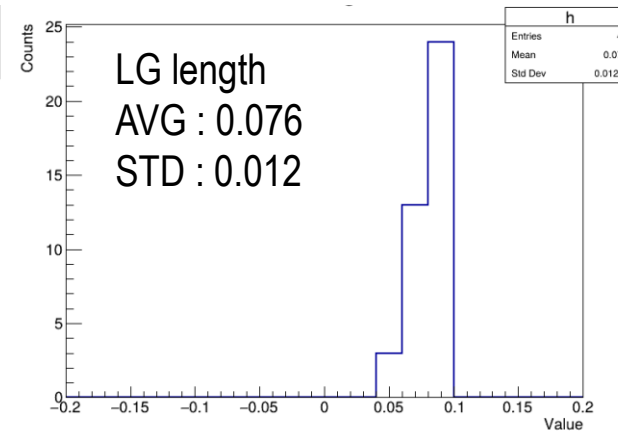

LG length
 AVG : 0.076
 STD : 0.012

G tech requirements :
 Length : ± 0.1 mm
 Side : ± 0.3 mm



Effective applied voltage



Ch 8, offset of 2.34 V

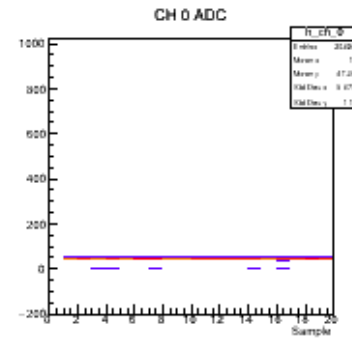
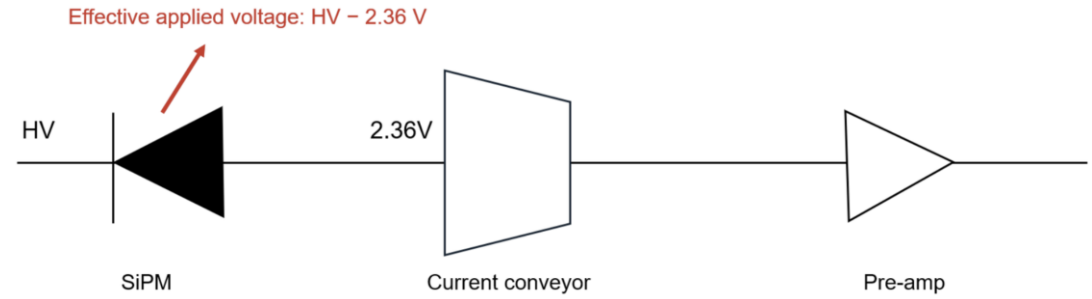

40 V
No signal
Only pedestal

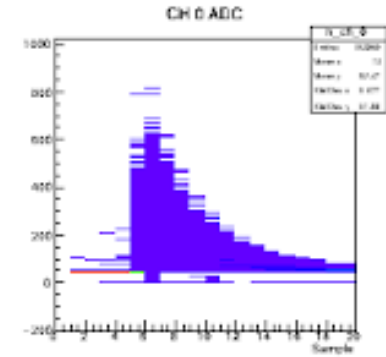

43 V
Signal

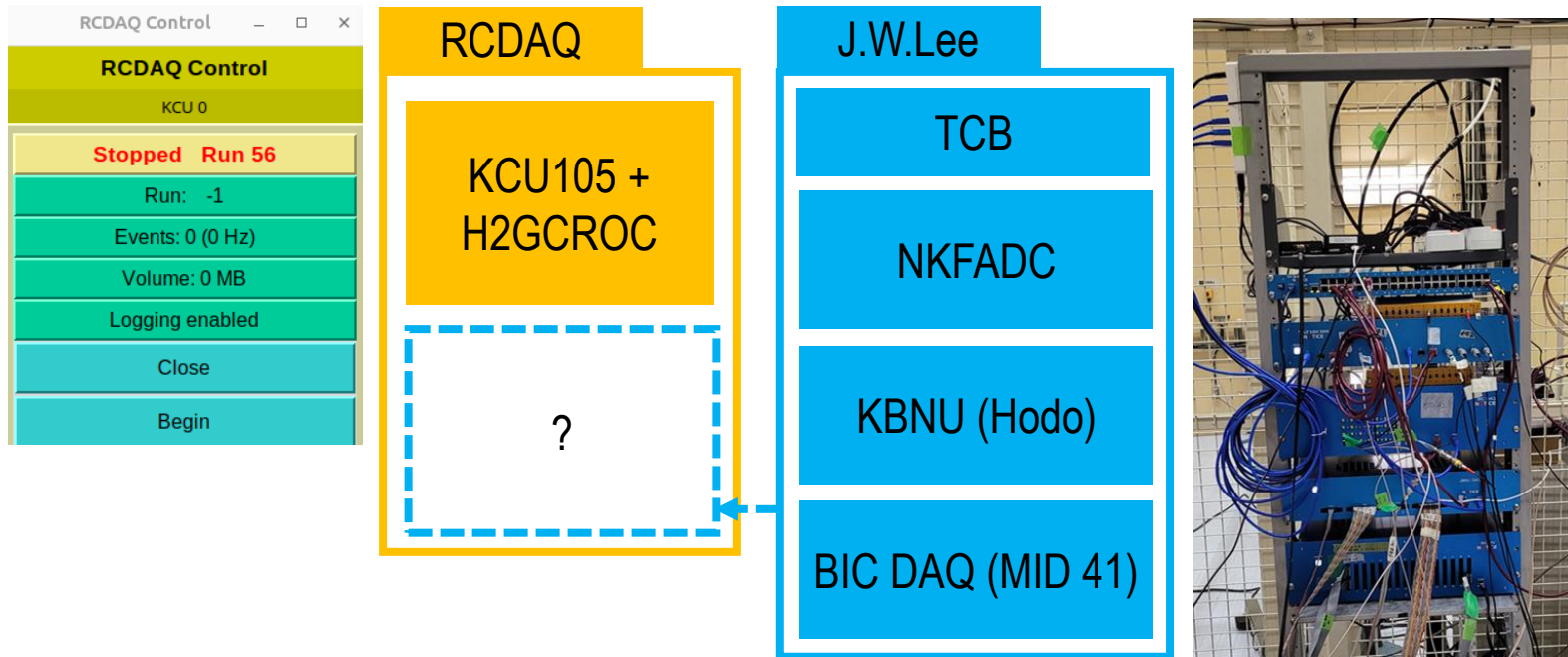

RCDAQ : DAQ integrator

Notice + RCDAQ integration ongoing

RCDAQ + Notice DAQ common decoder by J.W.Lee

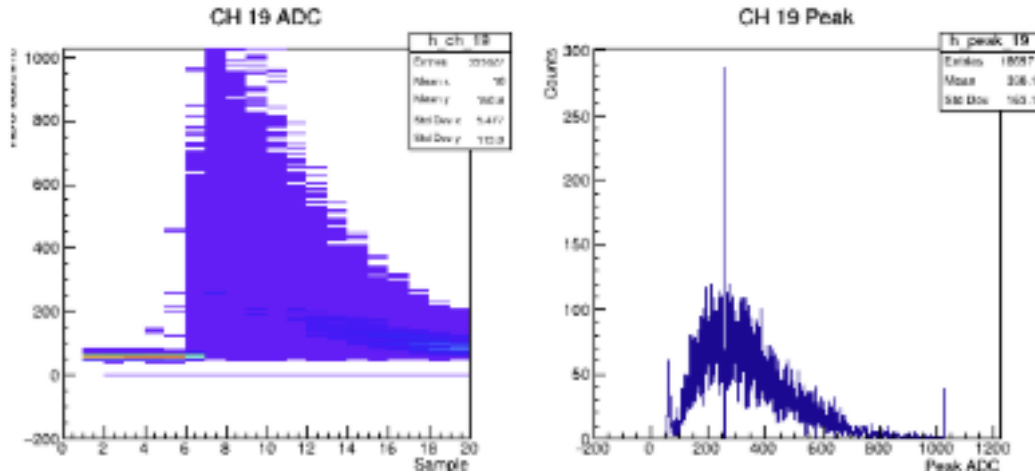

- delay40 - is the lower 5 bit of the ADC
- delay65 - is the 6th and 7th ADC bit
- Can be adjusted by changing the delay

257 → 256

“Missing code” in the ASIC

Byte	Delay65<2>	Delay65<1>	Delay65<0>	Delay40<2>	Delay40<1>	Delay40<0>	ref_adc<1>	ref_adc<0>
13	0	1	0	0	1	0	0	0
Byte	Delay9<2>	Delay9<1>	Delay9<0>	Delay87<2>	Delay87<1>	Delay87<0>	NA	ON_ref_adc
14	0	1	1	0	1	1	1	1

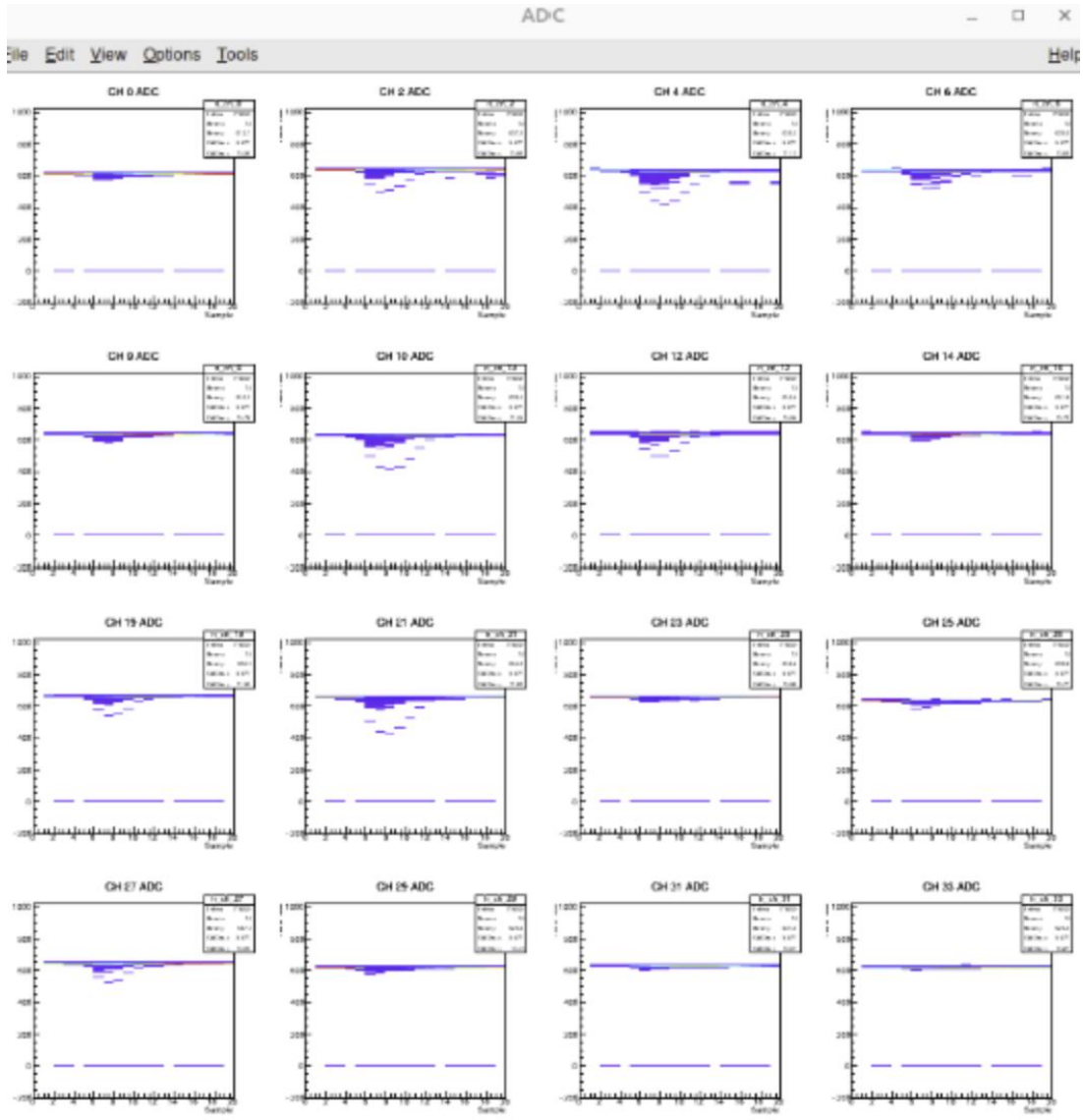

- Sometimes, polarity goes opposite

Solution

- Do pedestal scan at h2gcalibx
- Get few points for the injection, then stop
- Polarity comes back to normal

Maria simulation

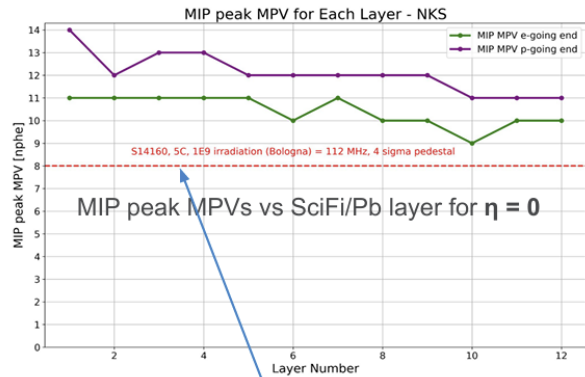
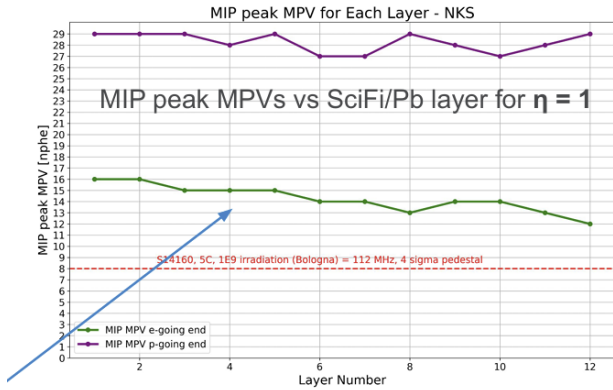

8 phe taken for illustration of the worst case scenario (4σ of pedestal)

Npe per layer (5 GeV muon, 90 deg)
MIP : ~10 Npe per SiPM

Max (P99.99) charge per SiPM array

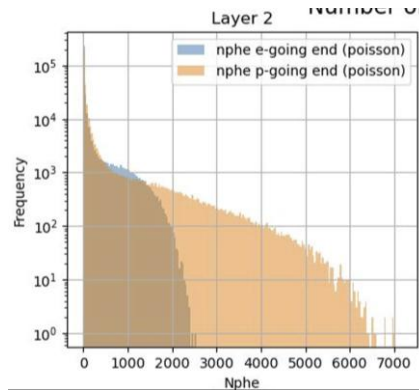
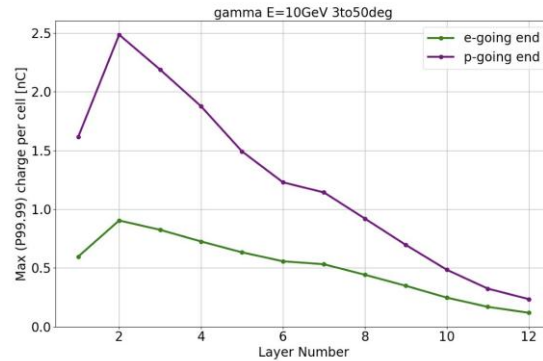

Npe per layer (10 GeV photon, 3-50 deg)
Best light yield : ~6250 Npe per SiPM

Max (P99.99) charge per SiPM array

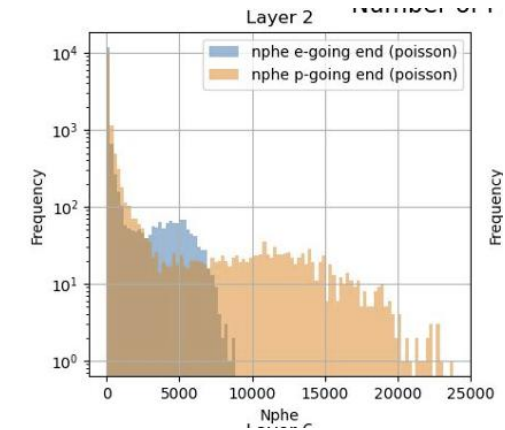
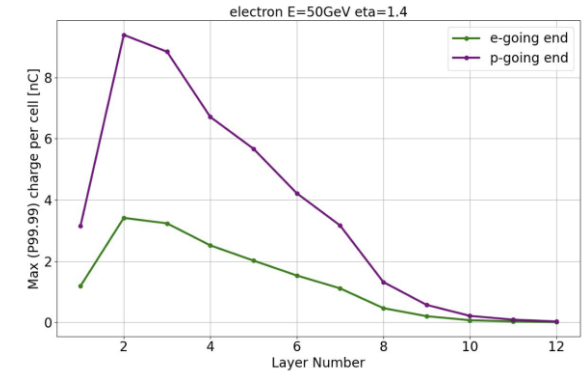

Npe per layer (50 GeV e-, 1.4 eta)
No precise E measurement required
But PID needed
~ 23750 Npe



Dynamic range (Npe)

Measured Npe (2507 CERN TB) & expected current

	MPV Npe per SiPM (9 cm ²)			Npe (4.5 cm ²)	pC (4.5cm ²)	LED V
e- (GeV)	1 st	2 nd	3 rd	3 rd	3 rd	
0.5	600	1100	700	350	140	
1	700	1800	1500	750	300	
2	1000	2800	3000	1500	600	1.79
3	1100	3800	4500	2250	900	
4	1150	4500	6000	3000	1200	1.83
5	1300	5500	7500	3750	1600	

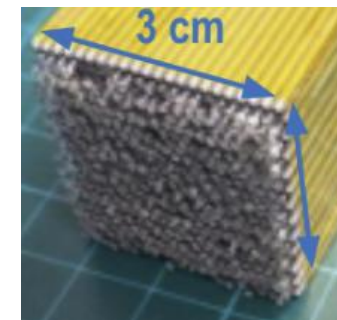

Area : 9 cm²

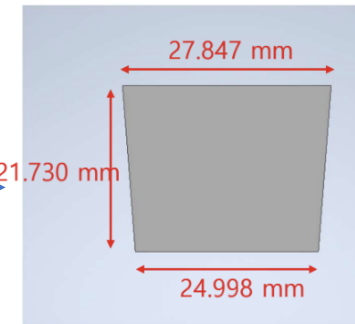

Area : ~4.5 cm²

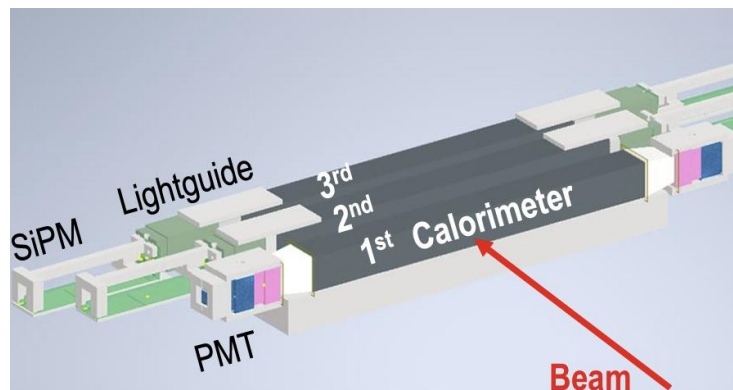

→ **Attenuation needed!**
Or lower HV...

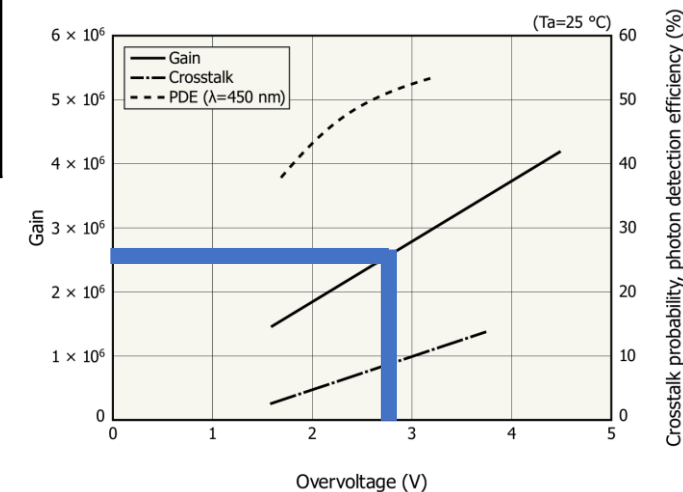

S14, 40.7 V :
Spe current ≈ 0.4 pC



Energy (GeV)	Readout
0.5 ~ 2	Low gain (ADC only)
0.5 ~ 2	High gain (ADC + ToT)
2 ~ 6	Low gain (ADC only)
2 ~ 6	High gain (ADC + ToT)

Gain Conveyer : 0.025 ~ 0.325

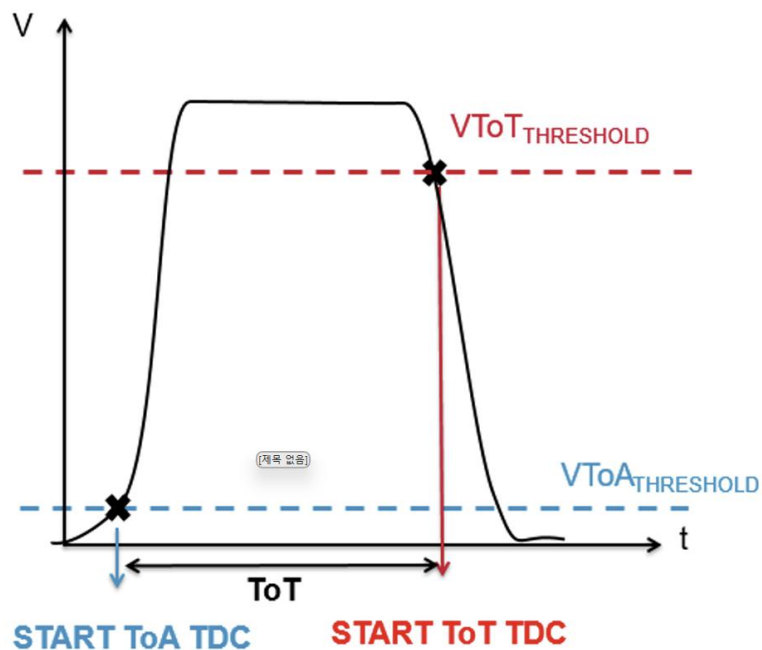

Spec

- Dynamic range : 160 fC ~ 320 pC (?)
- Real energy range : ~ 10 GeV

Decide..

- 1. Pre amp parameter (shaper) → ?
- 2. Summing logic (current dynamic range) → **6 setup?**
- 3. ADC or ToT, with different energy range (Gain) → **4 ?**

Ps.

- 1. Beam deadtime (1Gbe bottleneck, ~ 6.6 kHz estimated)
- 2. # of SiPM & calorimeter module (summing, SFIL etc..)

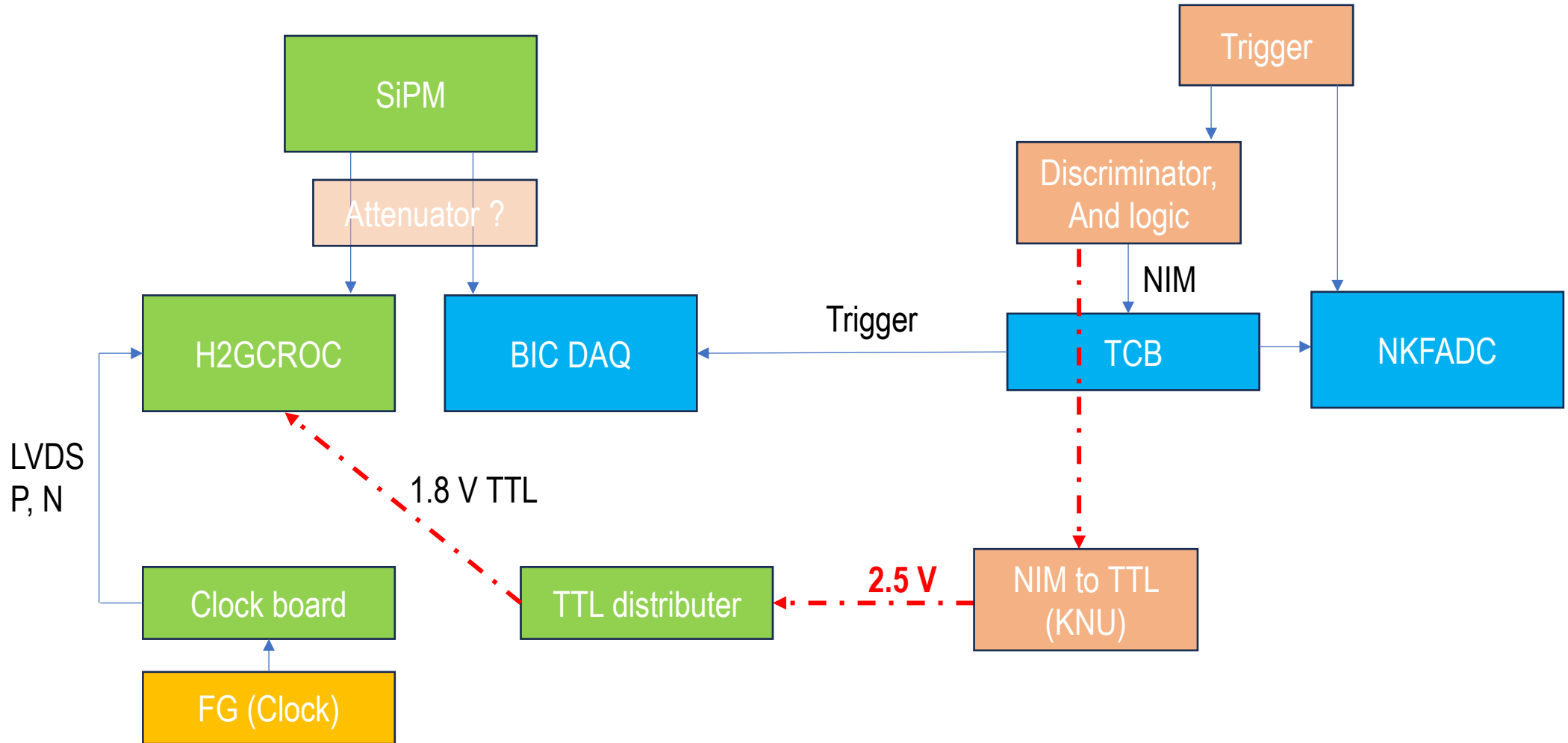

Running

```

1Gsetup_KCU.sh  mlp_test_setup.sh  setup_AstroPix.sh  setup_KCU0.sh  teardown_all.sh
CAEN_setup.sh  rc.log              setup_AstroPix.sh~ setup_KCU0.sh~
CAEN_setup.sh~ rc_setup.sh          setup_CAEN.sh      setup_KCU1.sh
CAEN_setup.sh.bak setup_all.sh Run_all CAEN.sh~      setup_KCU1.sh~
  
```

1Gsetup_KCU.sh : 1 KCU105 setup

```

rcdaq_client create_device device_h2gcroc3_10G 1 12001 10.1.2.208 11001 1 200
public:
  daq_device_h2gcroc3 (const int eventtype
    , const int subeventid
    , const char *ipaddr
    , const int port =11001
    , const int trigger =1
    , const int nr_packets=20);
~daq_device_h2gcroc3();
  
```

H2GCROC & RCDAQ manual

https://docs.google.com/document/d/14aa6CHx2kaIQcyo_qyt25AQdEL6MQvQqxUE9rOW0DO0/edit?tab=t.q9ycssyg52di

Analyze

```

int process_event (Event * e)
{
  if (!e) return 0;

  Packet *p = e->getPacket(12001);
  if (p)
  
```

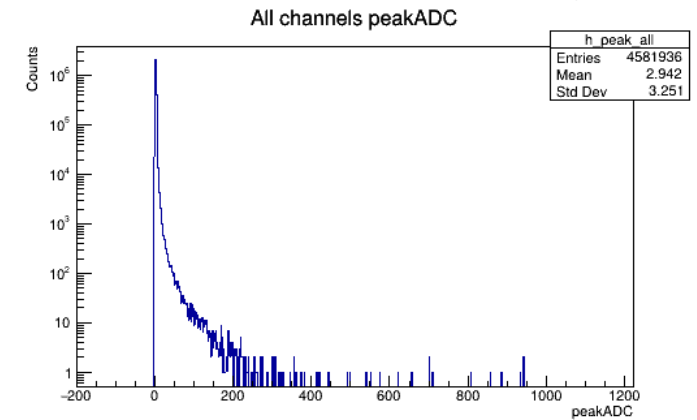
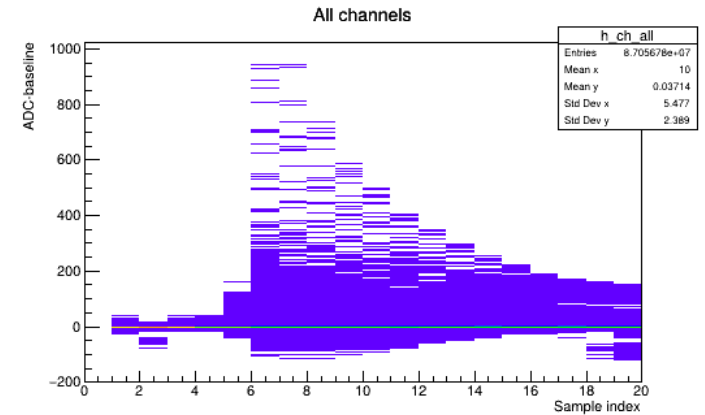

Offline analysis

Online monitoring in progress

Notice SiPM Fee board preamp

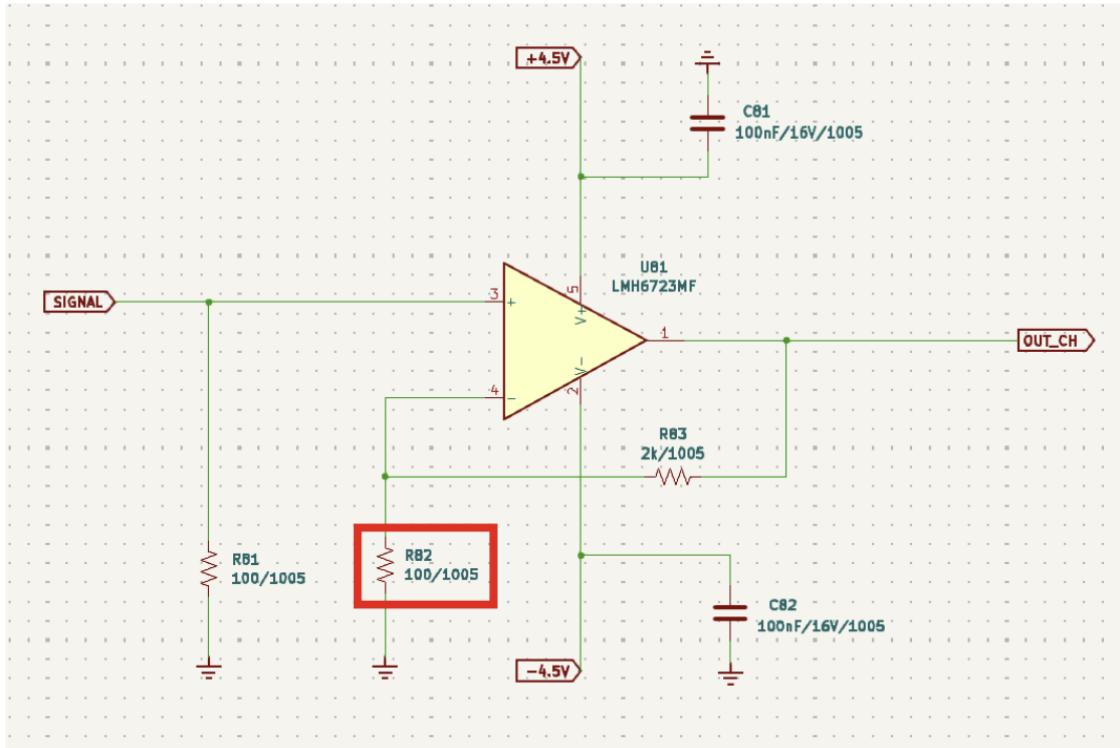



SiPM Lambda study

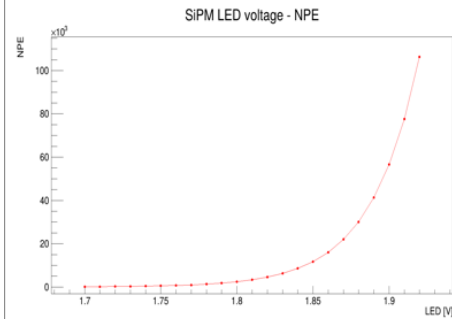

SiPM LED-NPE Graph

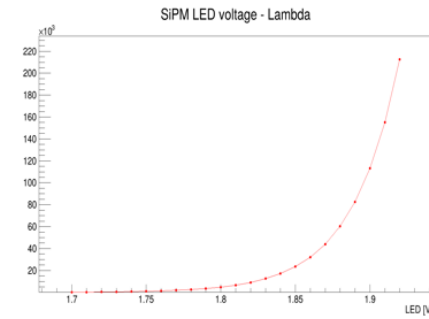

SiPM LED-Lambda Graph

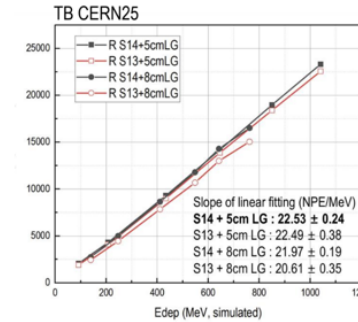

25CERN NPE

- SiPM LED voltage – NPE graph with led (Wavelength 465 nm ~ 470 nm)
- SiPM npe = SiPM Lambda (Photometry with Poisson dist.) X SiPM PDE (50 %)
- With 25CERN result, we can get the LED voltage range (1.77 V ~ 1.89 V)
- 1.79 V = SiPM NPE : 1232, Lambda : 2465
- 1.89 V = SiPM NPE : 28743, Lambda : 57487

LED volt	SiPM npe	Lambda
1.79 V	1232	2465
1.8 V	1688	3376
1.83 V	4340	8681
1.85 V	8150	16299
1.89 V	28743	57487

