

Status of the LUX Dark Matter Experiment



James Verbus

Brown University

Brookhaven Forum 2011

20 October 2011

Large Underground Xenon

- WIMP direct detection experiment
- Xenon dual-phase TPC
- Underground operations start at Sanford Laboratory in 2012
- Large: 350 kg Xe, 100 kg fiducial; very strong discovery potential

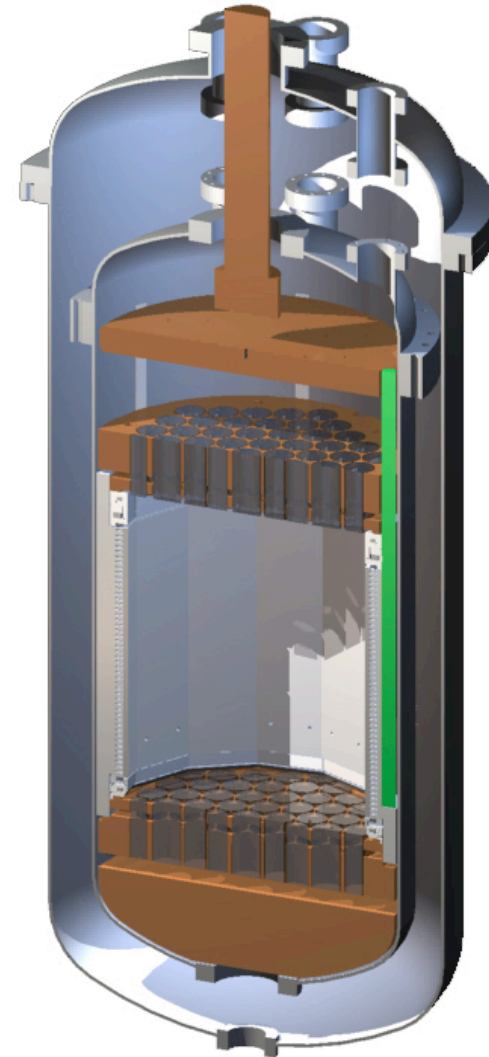

The LUX Collaboration



Brown

Richard Gaitskell	PI, Professor
Simon Fiorucci	Research Associate
Monica Pangilinan	Postdoc
Jeremy Chapman	Graduate Student
Carlos Hernandez Faham	Graduate Student
David Malling	Graduate Student
James Verbus	Graduate Student



Case Western

Thomas Shutt	PI, Professor
Dan Akerib	PI, Professor
Mike Dragowsky	Research Associate Professor
Carmen Carmona	Postdoc
Ken Clark	Postdoc
Tom Coffey	Postdoc
Karen Gibson	Postdoc
Adam Bradley	Graduate Student
Patrick Phelps	Graduate Student
Chang Lee	Graduate Student
Kati Pech	Graduate Student



Harvard

Masahiro Morii	PI, Professor
Michal Wasenko	Postdoc
John Oliver	Electronics Engineer



Lawrence Berkeley + UC Berkeley

Bob Jacobsen	Professor
Jim Siegrist	Professor
Bill Edwards	Engineer
Joseph Rasson	Engineer
Mia ihm	Graduate Student



Lawrence Livermore

Adam Bernstein	PI, Leader of Adv. Detectors Group
Dennis Carr	Mechanical Technician
Kareem Kazkaz	Staff Physicist
Peter Sorensen	Postdoc



University of Maryland

Carter Hall	PI, Professor
Douglas Leonard	Postdoc

Collaboration was formed in 2007 and fully funded by DOE and NSF in 2008.



UC Santa Barbara

Harry Nelson	PI, Professor
Dean White	Engineer
Susanne Kyre	Engineer



LIP Coimbra

Isabel Lopes	PI, Professor
Jose Pinto da Cunha	Assistant Professor
Vladimir Solovov	Senior Researcher
Luiz de Viveiros	Postdoc
Alexander Lindote	Postdoc
Francisco Neves	Postdoc
Claudio Silva	Postdoc



SD School of Mines

Xinhua Bai	PI, Professor, Physics Group Leader
Mark Hanardt	Graduate Student



Texas A&M

James White	PI, Professor
Robert Webb	Professor
Rachel Mannino	Graduate Student
Tyana Stiegler	Graduate Student
Clement Sofka	Graduate Student



UC Davis

Mani Tripathi	PI, Professor
Robert Svoboda	Professor
Richard Lander	Professor
Britt Hollbrook	Senior Engineer
John Thomson	Senior Machinist
Matthew Szydagis	Postdoc
Jeremy Mock	Graduate Student
Melinda Sweany	Graduate Student
Nick Walsh	Graduate Student
Michael Woods	Graduate Student
Sergey Uvarov	Graduate Student



The most recent collaboration meeting was held in Lead, SD in March 2011.



University of Rochester

Frank Wolfs	PI, Professor
Wojtek Skutski	Senior Scientist
Eryk Druszkiewicz	Graduate Student
Mongkol Moongweluwan	Graduate Student



U. South Dakota

Dongming Mei	PI, Professor
Wengchang Xiang	Postdoc
Chao Zhang	Postdoc
Oleg Perevozchikov	Postdoc



Yale

Daniel McKinsey	PI, Professor
Peter Parker	Professor
James Nikkel	Research Scientist
Sidney Cahn	Lecturer/Research Scientist
Alexey Lyashenko	Postdoc
Ethan Bernard	Postdoc
Blair Edwards	Postdoc
Louis Kastens	Graduate Student
Nicole Larsen	Graduate Student

LUX Anatomy

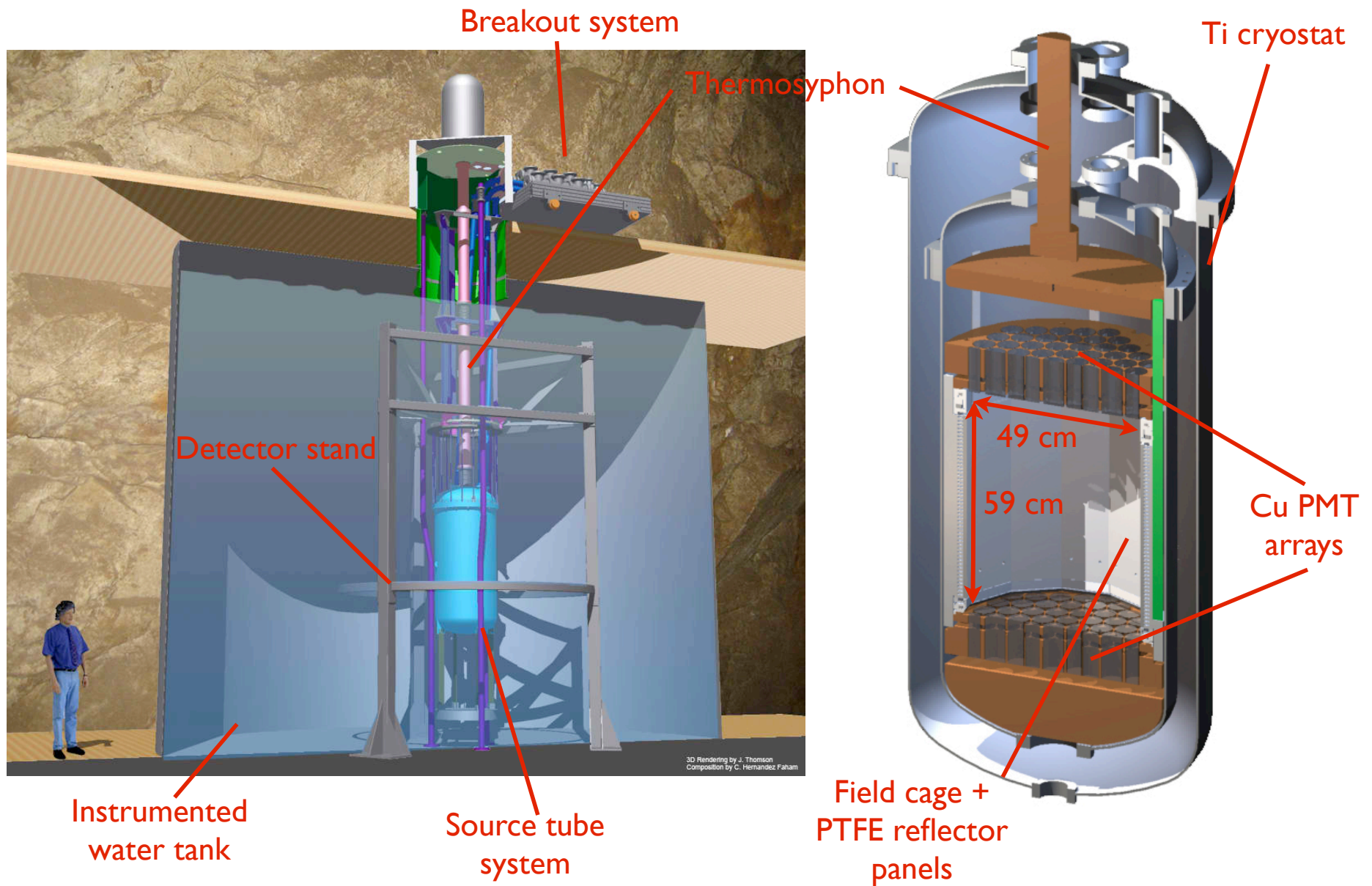

LUX Anatomy



LUX Signals

- S1: scintillation photons
- S2: ionization electrons
- 3D event position reconstruction

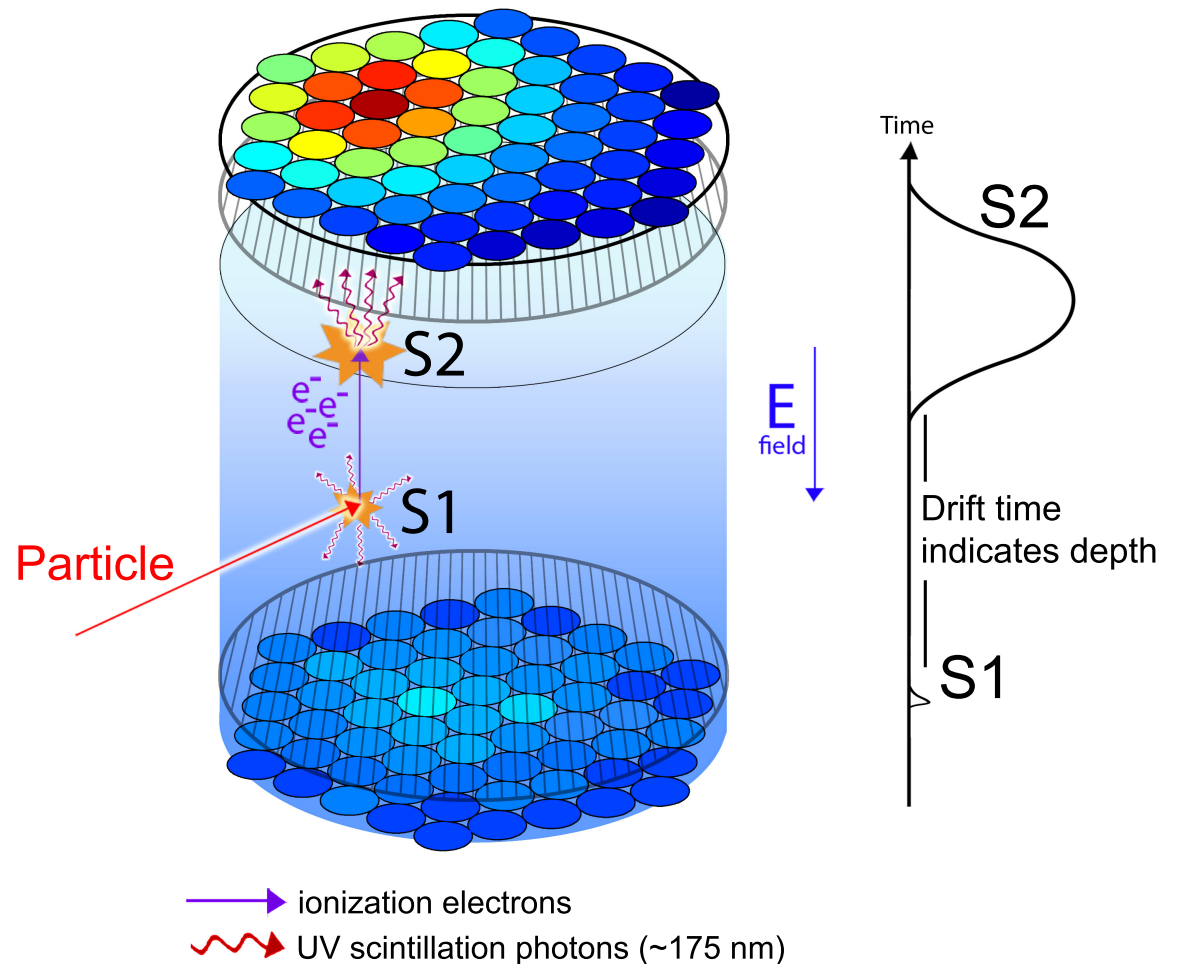

ER / NR discrimination

- Provides ER background discrimination
- >99.5% ER rejection

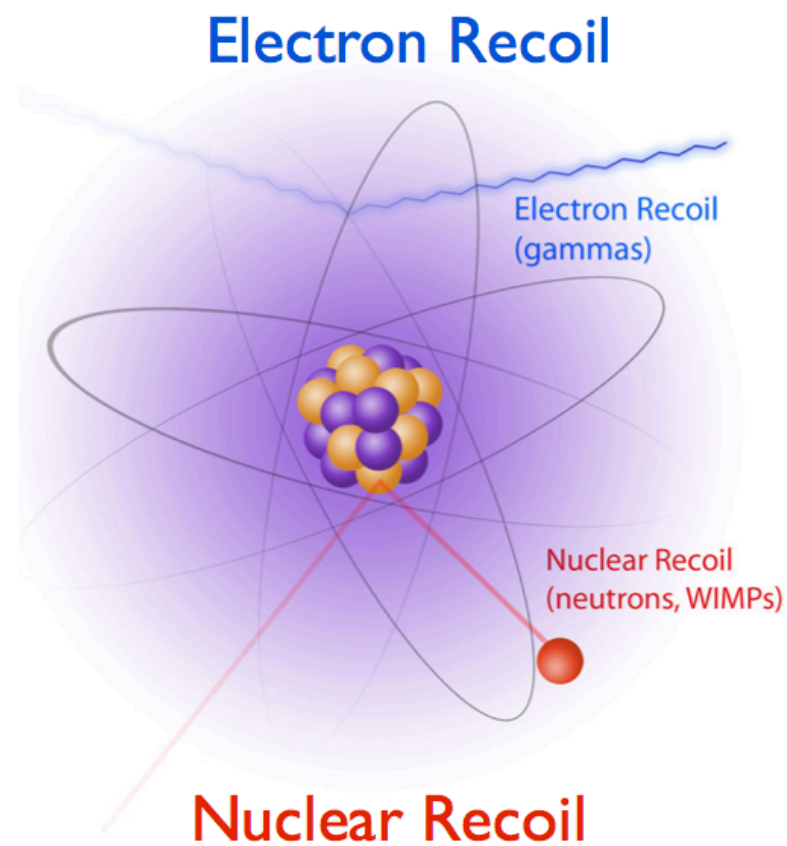
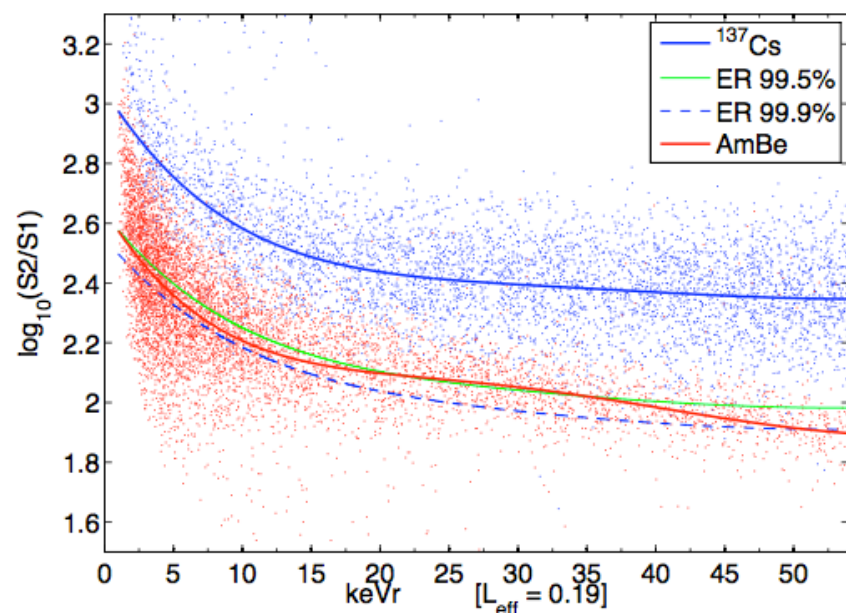

Background Reduction

- Go Underground ($\sim 10^{-7}$ reduction in muon flux) **5-25 keV_{ee} single scatter** $\log_{10}(\text{DRU}_{ee})$
- Water Tank (8 m dia, 6 m height)
- Xe self-shielding
- Manage internal backgrounds
 - Materials screening program
 - Remove Xe contaminants (Kr-85)
 - Minimize Rn exposure (α, n)

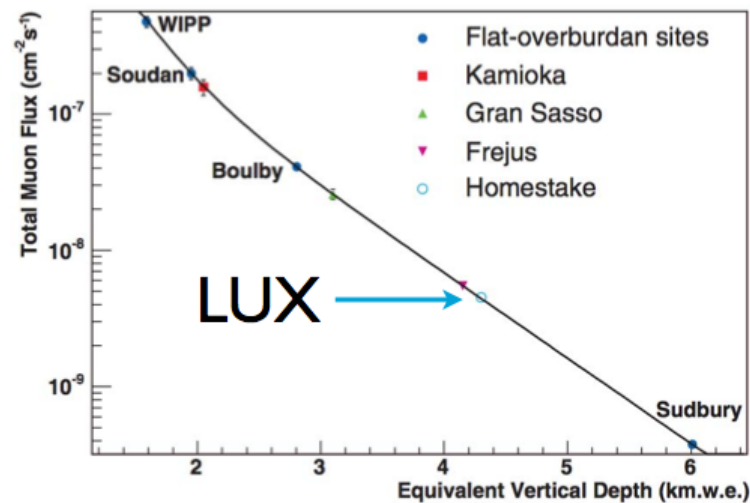
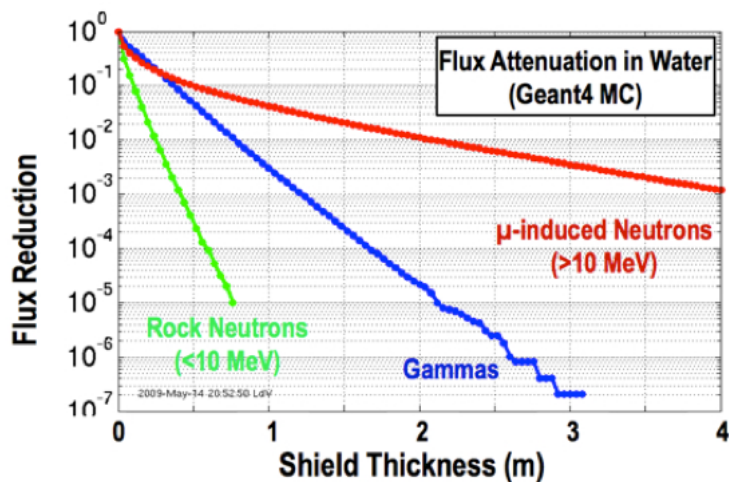
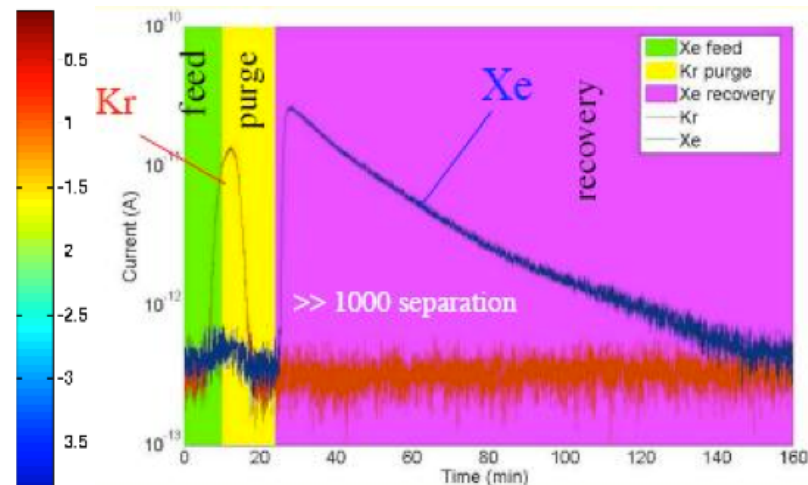
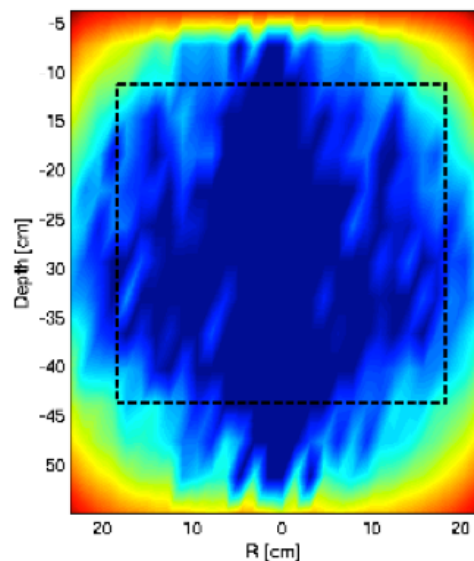

Sanford Laboratory at Homestake

- Homestake gold mine retired in 2000
 - 8000' deep
 - 370 miles of tunnels
 - Homestake Solar Neutrino Experiment - 2002 Nobel Prize
- LUX in Davis Cavern - 4850' level

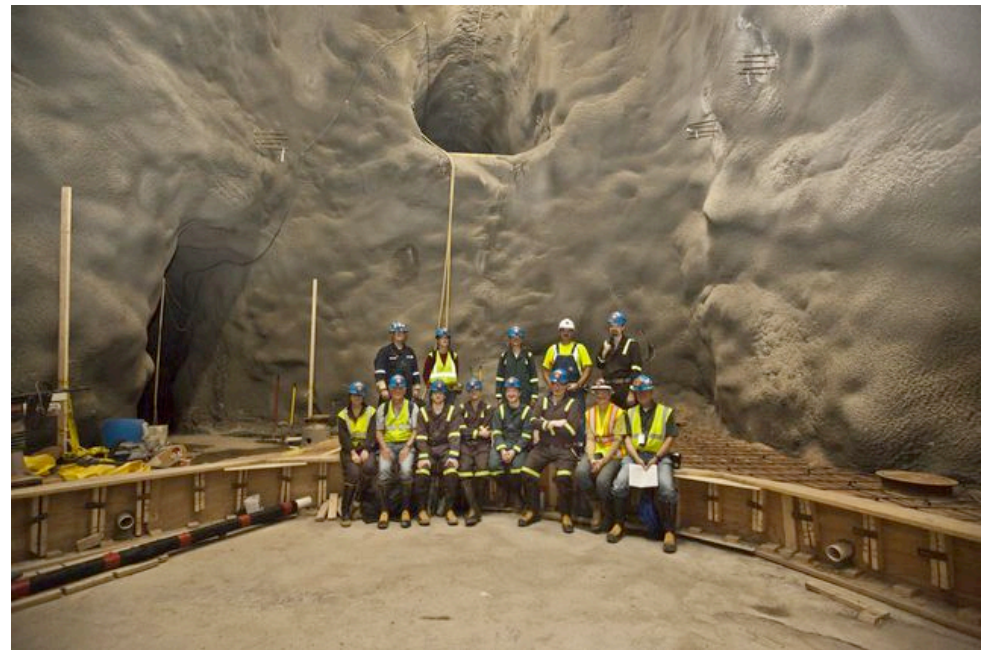
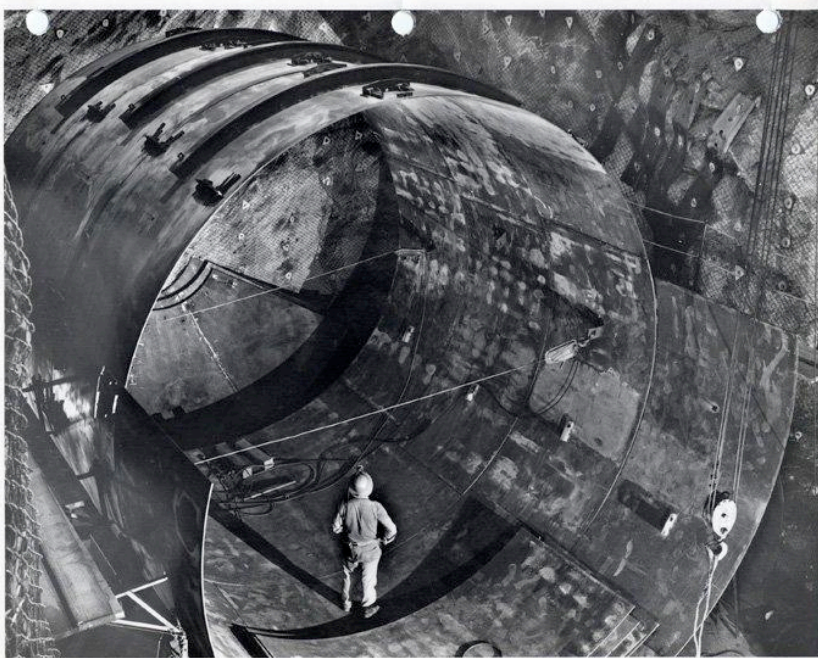

The LUX Surface Facility at Sanford Lab

- Identical to underground floor plan
- Detector construction / testing done on the surface
- Sealed detector transport underground



Surface Run01

- Demonstrate controlled cooldown using thermosyphon system
- Avoid gradients in HDPE and PTFE panels < 10 K vertically and < 5 K horizontally
- Demonstrate stable operation at ~ 180 K
- ~ 70 thermometers
- 1 atm Ar exchange gas
- 20 photomultiplier tubes + corresponding analog / DAQ electronics

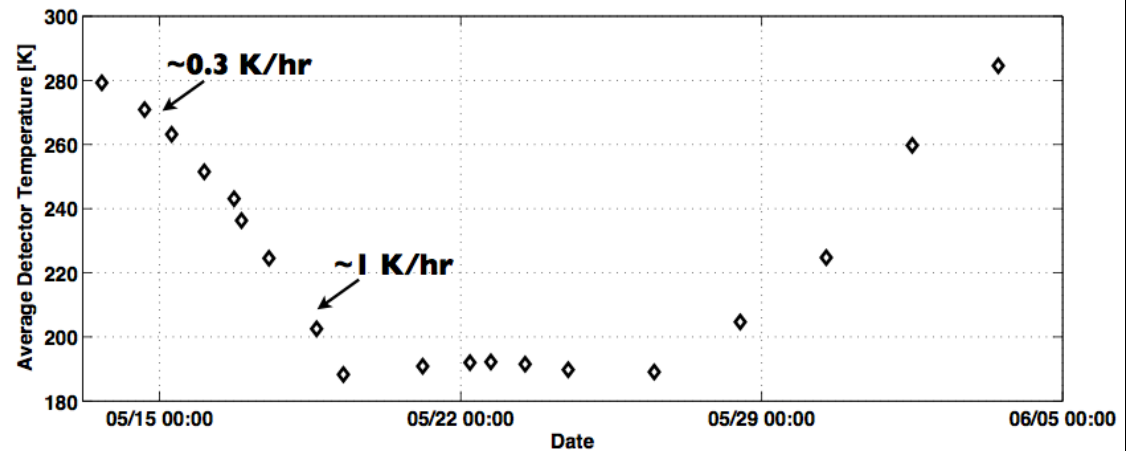
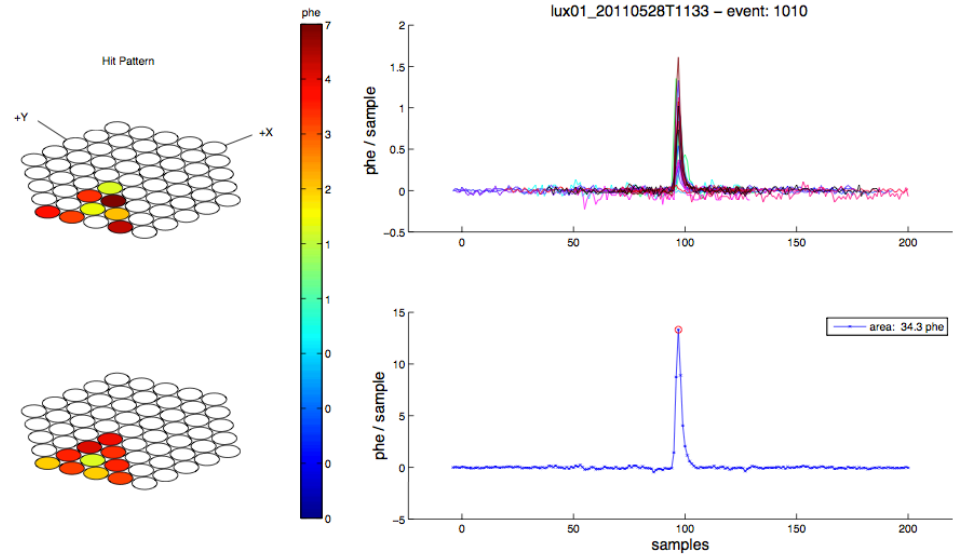

Surface Run02

- Currently underway
- Full signal chain
 - 122 photomultiplier tubes + corresponding analog / DAQ electronics
 - Charge sensitive preamplifier
 - Data distribution and analysis chain
- 350 kg xenon
 - First condensation
 - Circulation / purification
 - Storage and recovery system
- Water Tank
- Calibration System
- Going underground early 2012!

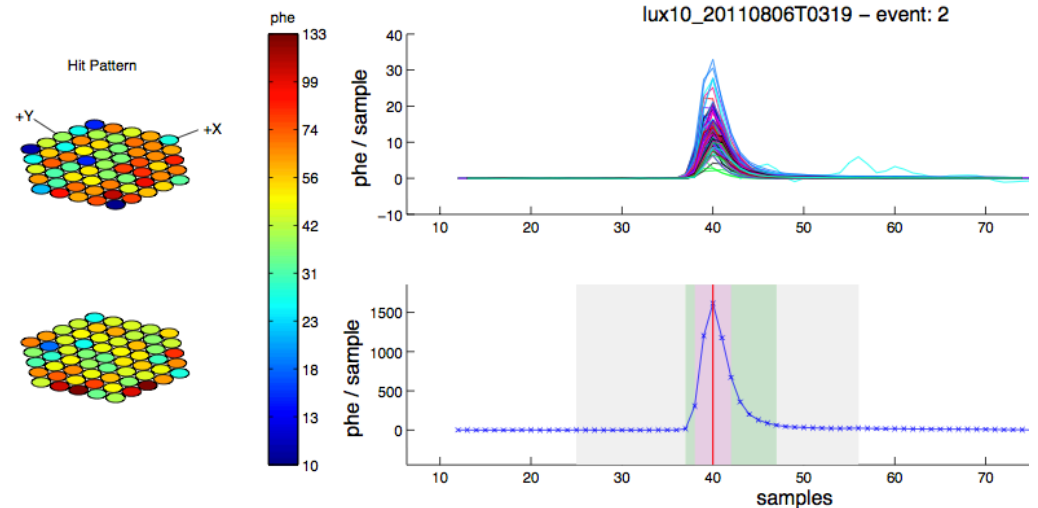
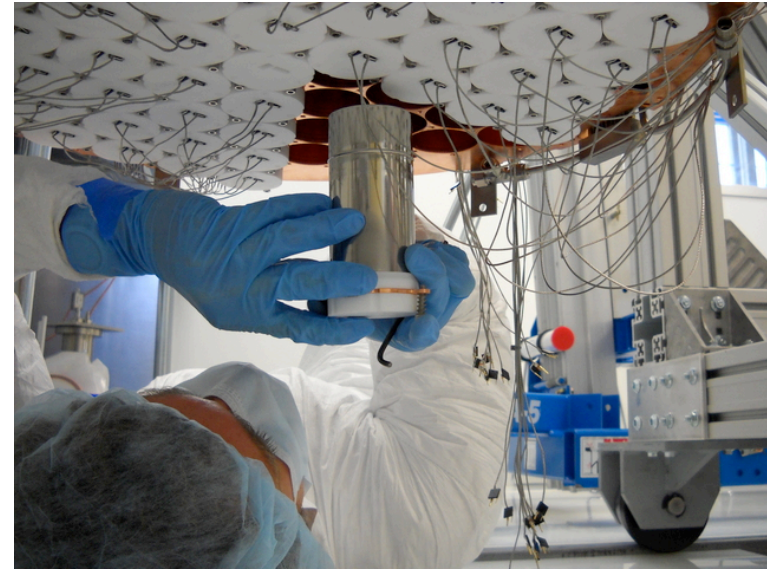

LUX: The First 40 Days

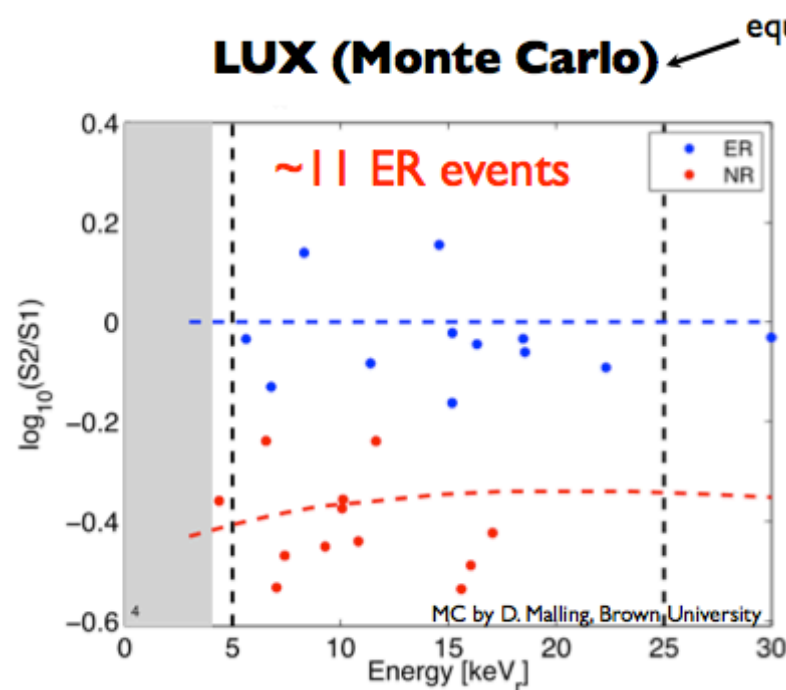

LUX signal and background expectation for 4,000 kg-days net exposure. WIMP events assume $m = 100 \text{ GeV}$, $\sigma = 1 \times 10^{-44} \text{ cm}^2$.

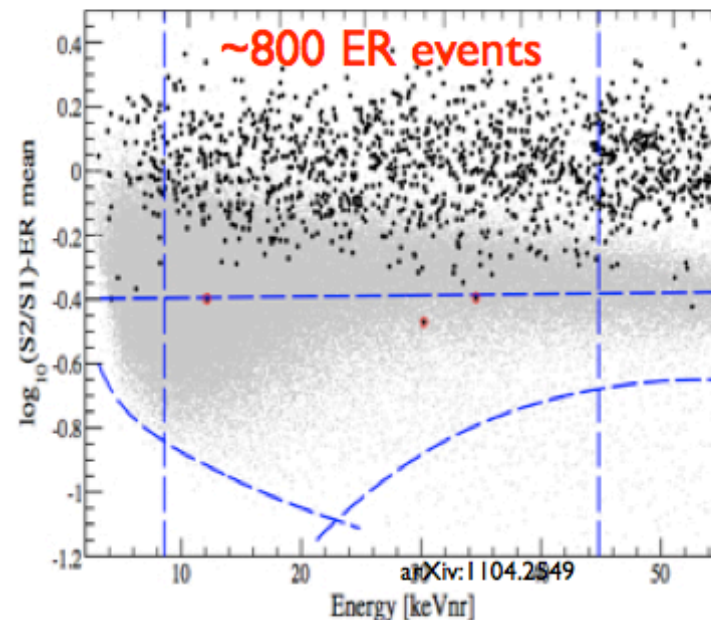

XENON100 4,000 kg-days result for comparison.
Note higher ER rate - ~800 events in 100 days x 40 kg fiducial
~60% due to ^{85}Kr with remaining 40% due to Compton scattering of external gamma background

- **Red Points:** WIMP events after only 40 days (equivalent exposure to all of XENON100 run) assuming a WIMP model for mass 100 GeV at current best 90% CL Exclusion Limit
- **Blue Points:** Total # of single scatter electron recoil events in LUX (before any other cuts) after 40 days of running. Expect only 11 events in 100 kg fiducial x 40 days for a net 4,000 kg exposure.
- **LUX - Strong Emphasis on WIMP Discovery / Plan to run LUX for 300 days**

Summary

- Detector fully constructed in the Surface Facility
- Extensive testing of all subsystems above ground
- Surface Run02 currently underway
- Underground deployment: early 2012
- Significant discovery capability

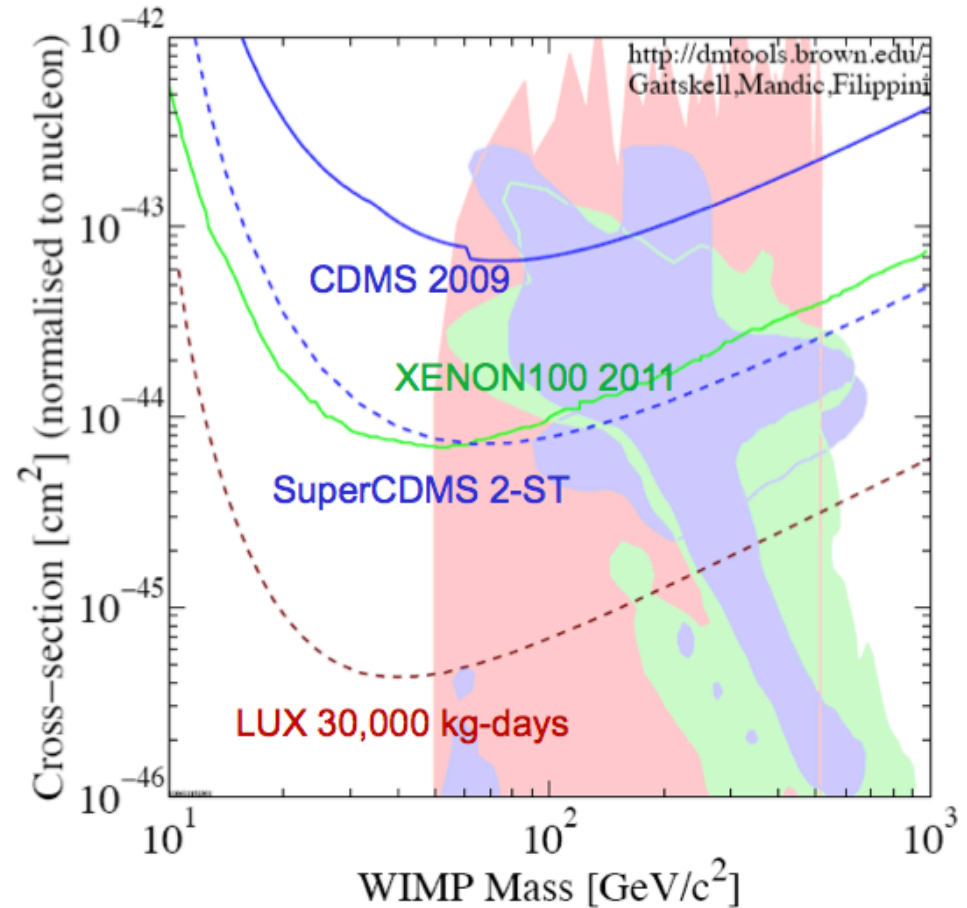

Thank You!



Extra Slides

Go Underground

- Reduction of Muon Flux
 - Surface: ~ 1 / hand / s
 - 4850' (4300 MWE):
 ~ 1 / hand / year

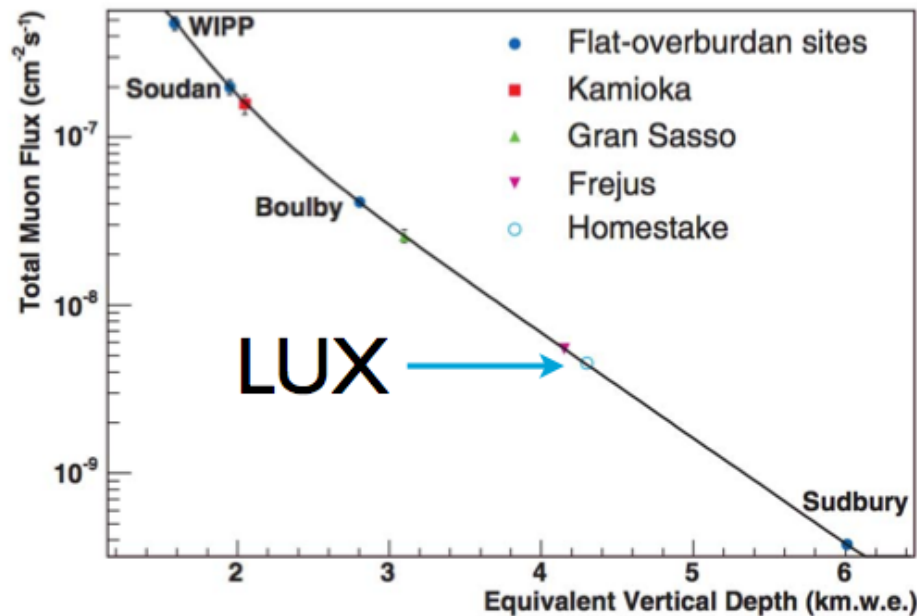

Water Tank

- 8 m diameter, 6 m height
- 20 Photomultiplier tubes for muon veto

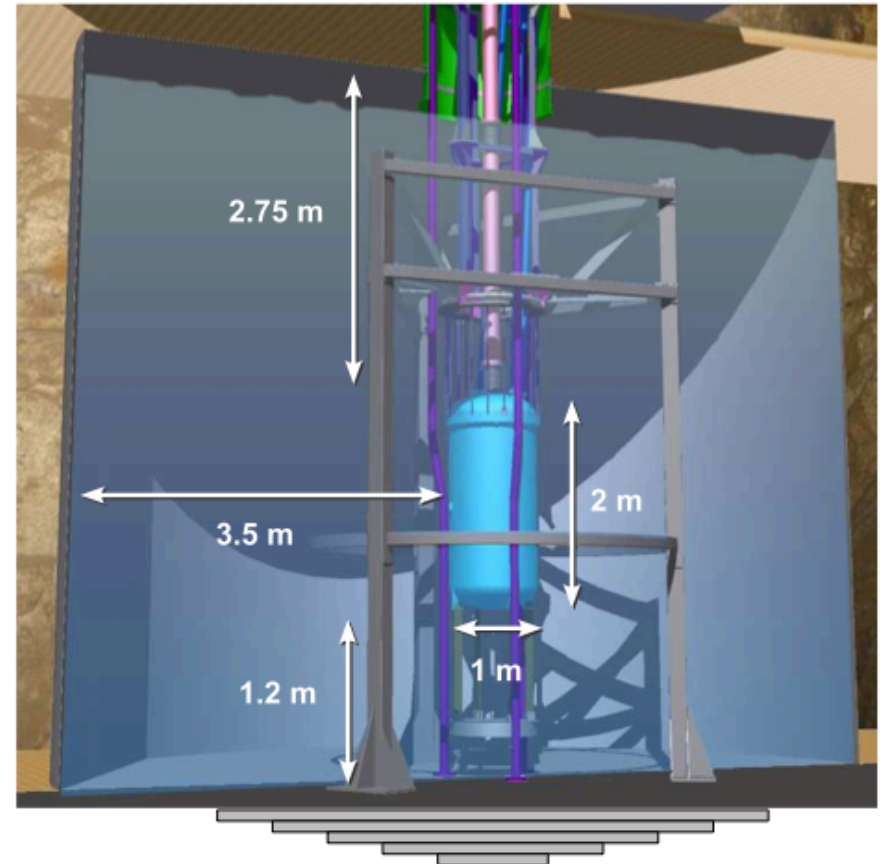
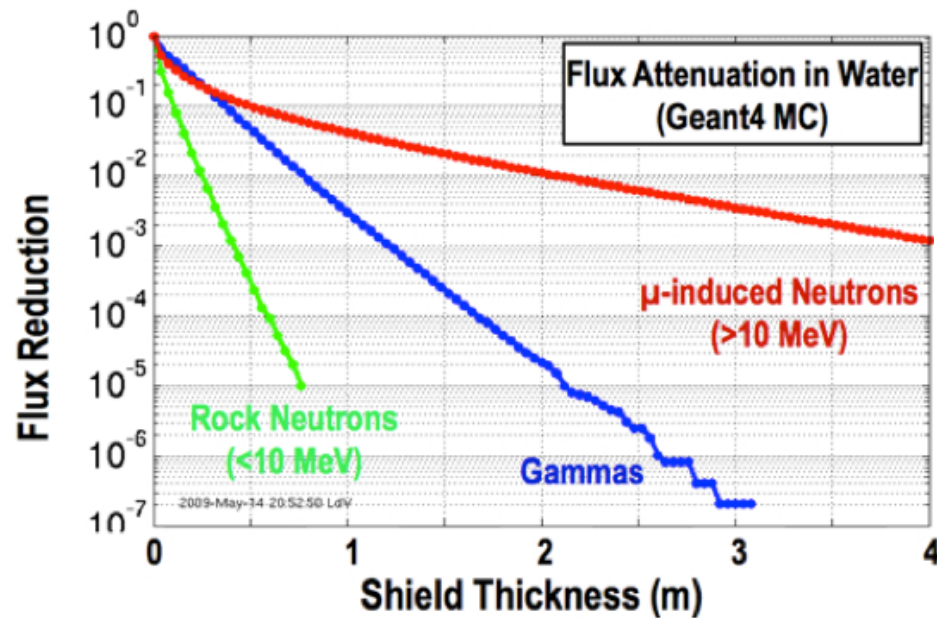

Manage Internal Backgrounds

- Screen construction materials
- Remove Xe contaminants
- Kr-85
- Minimize Rn exposure - (α, n) in PTFE

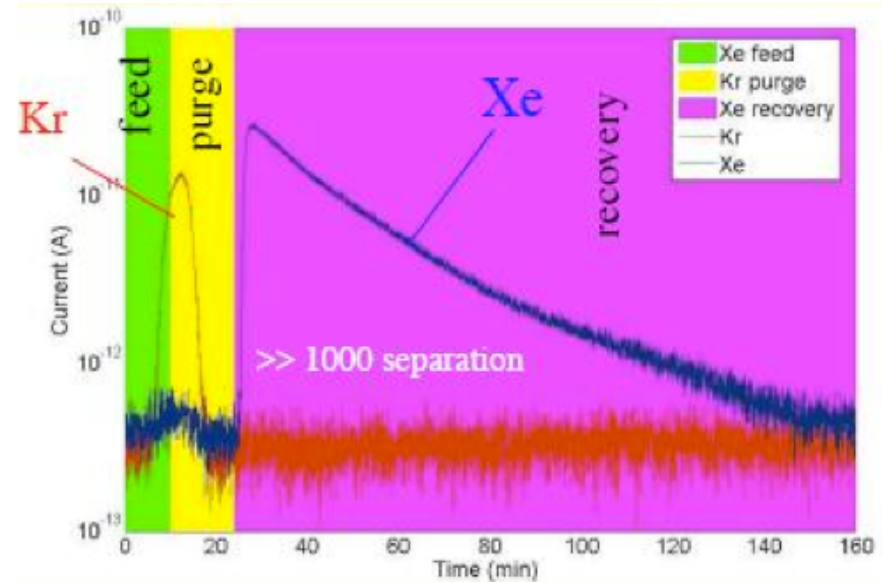

	Unit	Screening Result				
		U238	Th232	Co60	K40	Sc46
PMTs	mBq/PMT	9.5±0.6	2.7±0.3	2.6±0.1	66±2	
Ti	mBq/kg	<0.18	<0.25			4.4±0.3*
Cu	mBq/kg			2.1±0.19*		
PTFE	mBq/kg	<3	<1			
HDPE	mBq/kg	<0.5	<0.35			
Stainless steel**	mBq/kg			19±1		

**Type 304 stainless steel used in electric field grids

*Cosmogenic equilibrium at 1 mile above SL; decays below ground

Xenon Self Shielding

- 100 kg fiducial region
- Shielding improves greatly by scaling up Xe mass

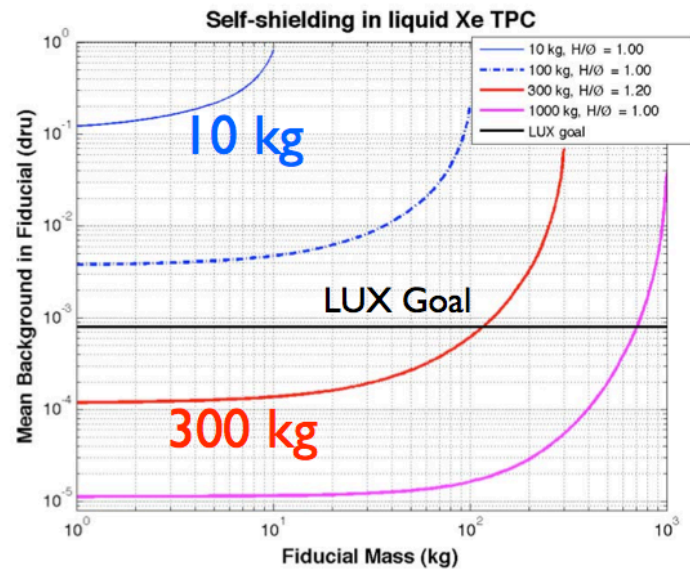

5-25 keV_{ee} single scatter $\log_{10}(\text{DRU}_{ee})$

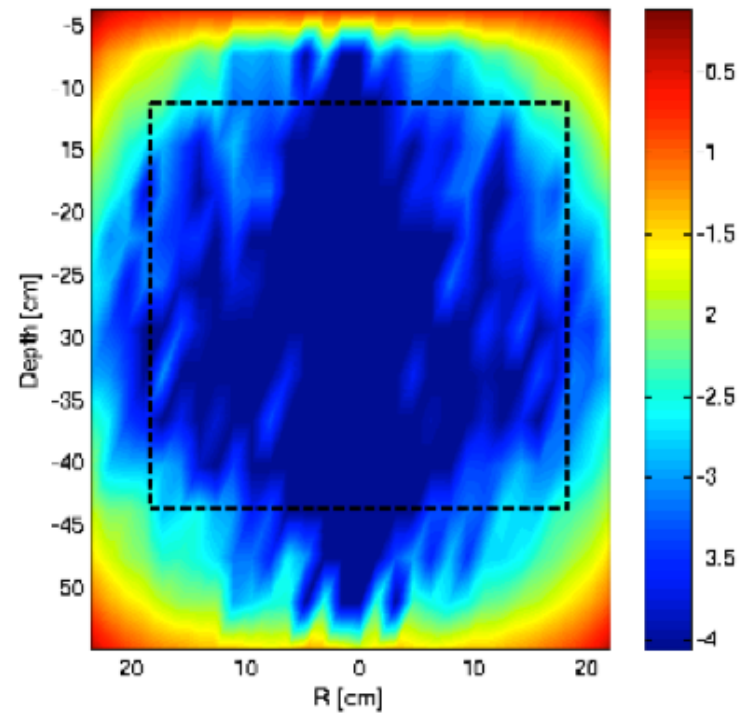

Xe Signal Generation

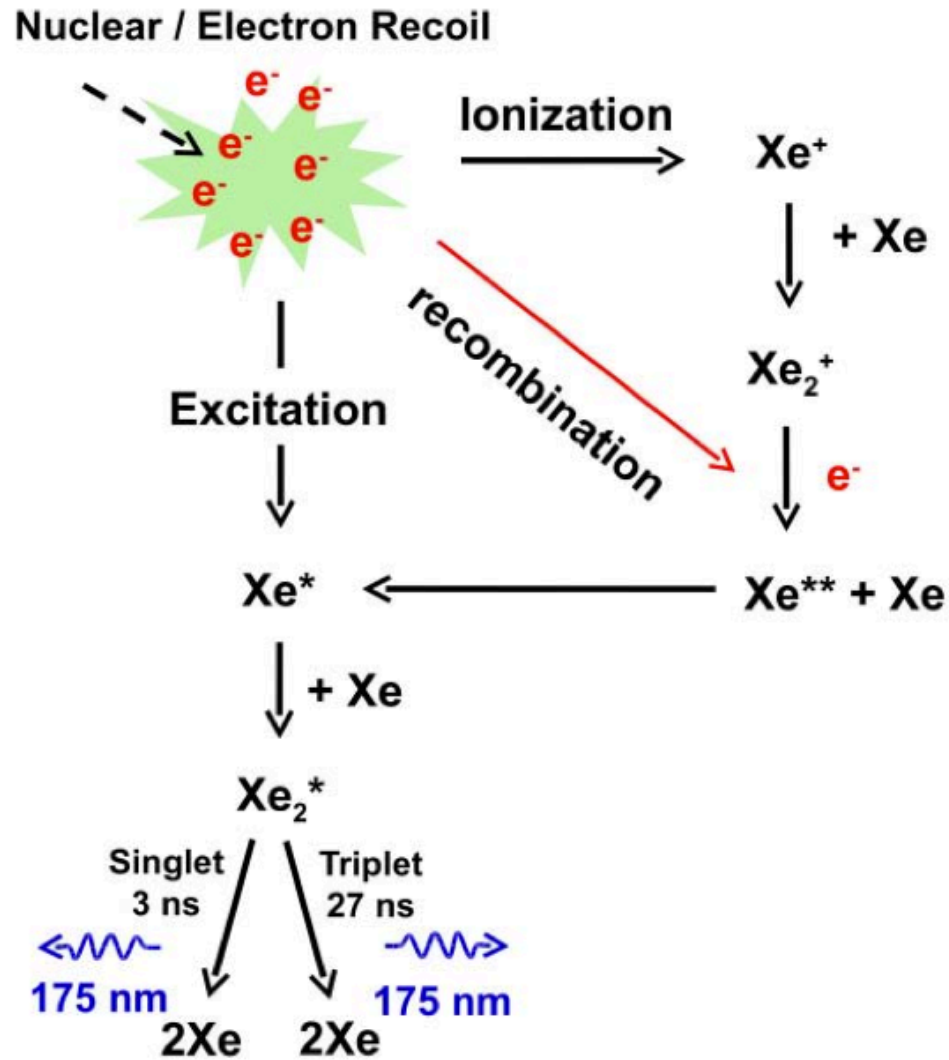

LUX DAQ

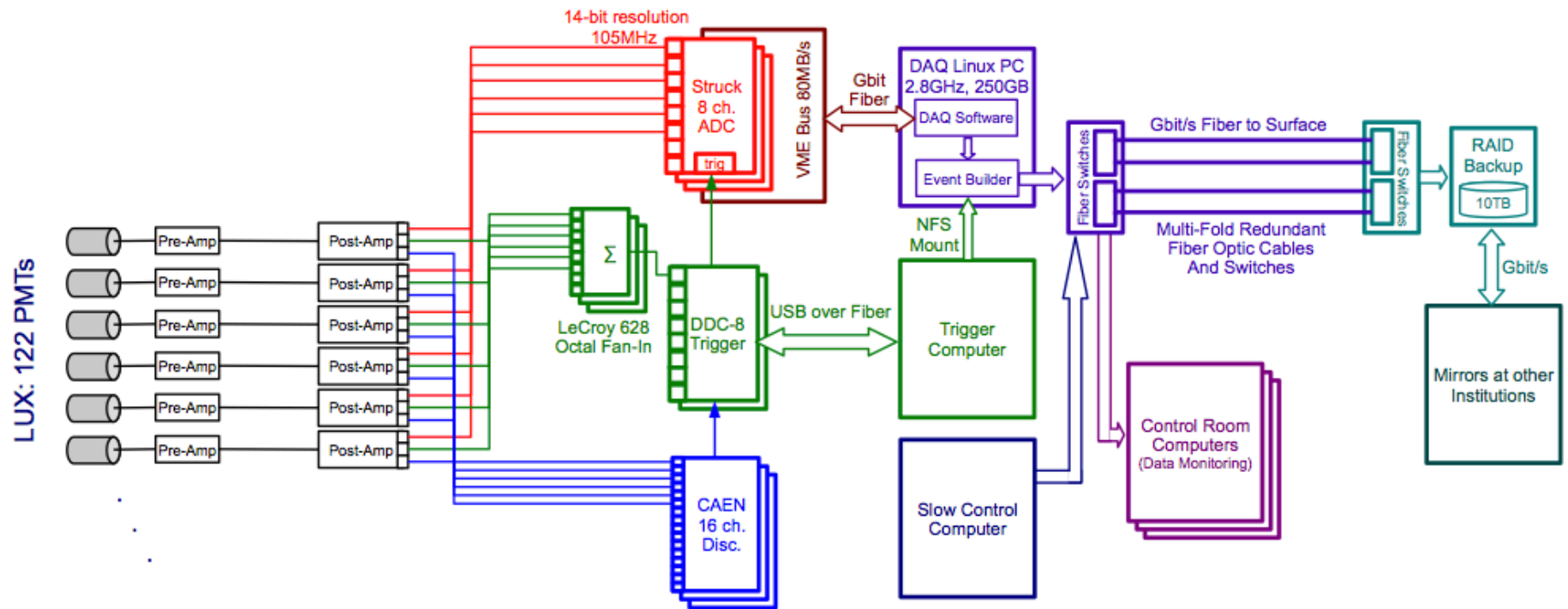

- Custom-built analog electronics
- Specially shaped signals for the digitizer, digital trigger, and analog trigger
- 1.5kHz acquisition rate w/o deadtime = dark matter calibrations w/ zero deadtime
- >99.99% zero suppression
- 95% single photoelectrons $> 5\sigma$ upward fluctuation in baseline noise
- 120 keV_{ee} dynamic range with dark matter search gains

DAQ POD Mode

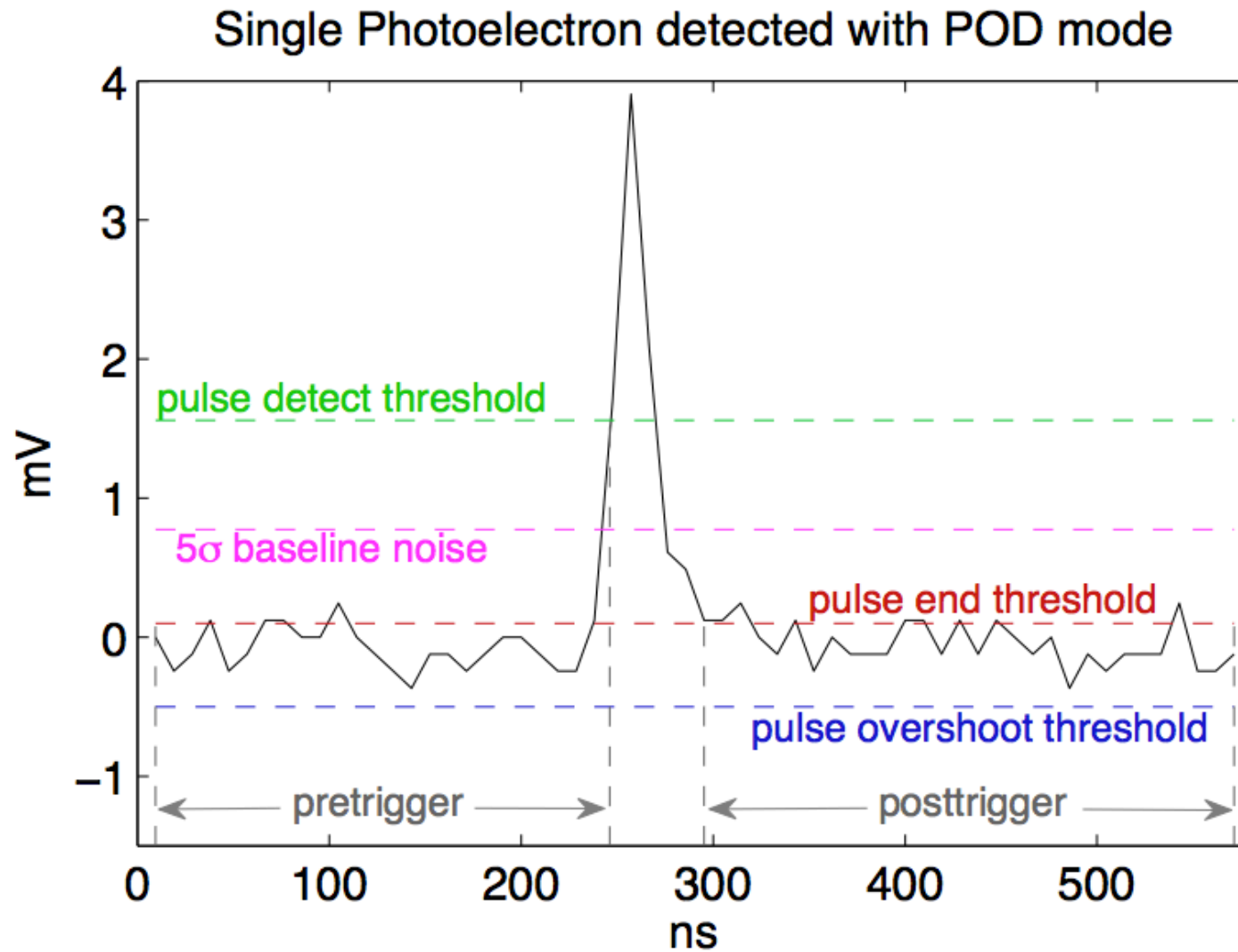

Purification

Purification vs. Time, Run009

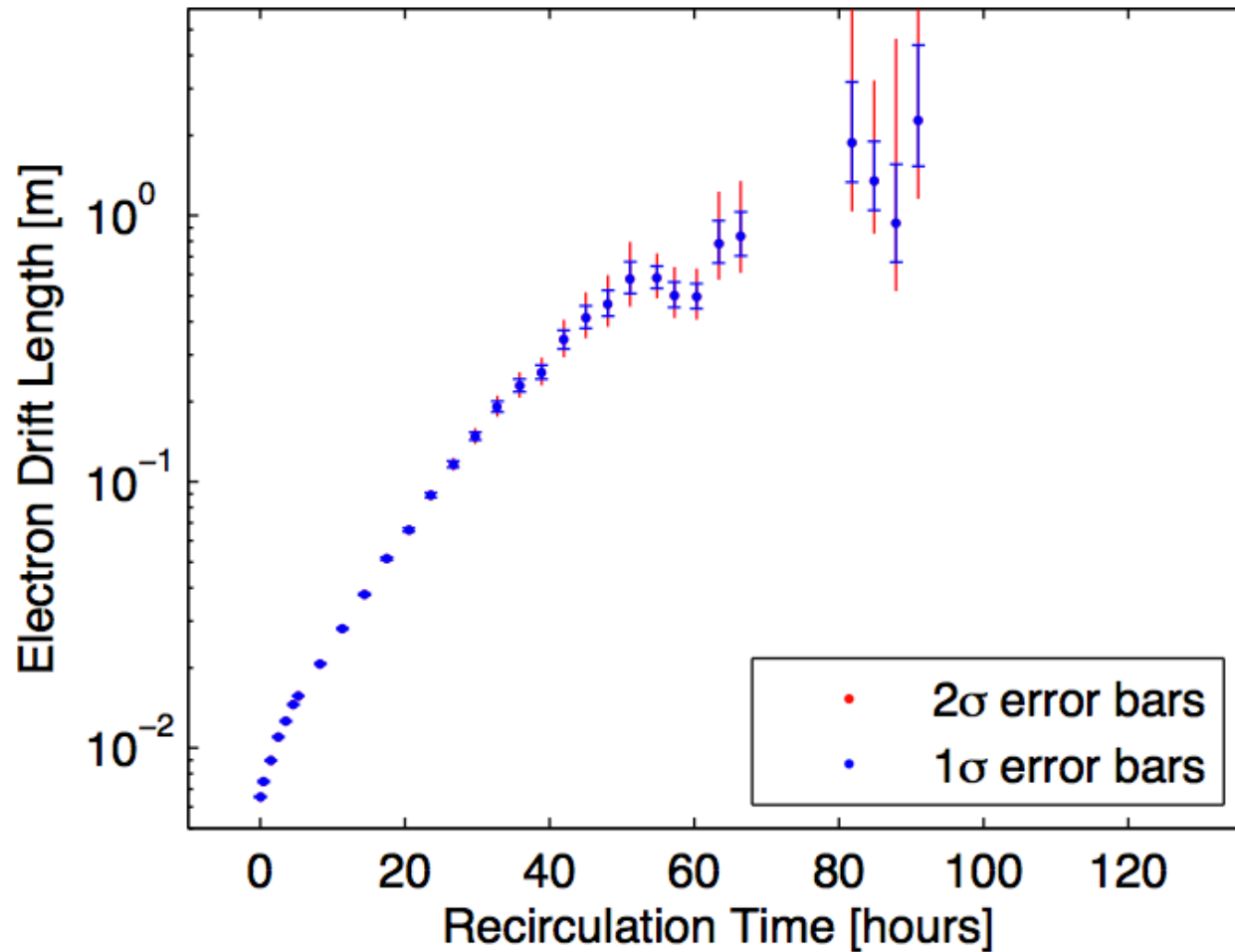

- ~9 hr purification time constant at 20 slpm (LUX will run at 50 slpm)
- > 2 m electron drift length
- This is an order of magnitude faster recirculation than ever achieved before