

University of Kentucky Accelerator Activities

Jeff Vanhoy,

US Naval Academy, Annapolis, Maryland



University of Kentucky

Yongchi Xiao, postdoc
Erin Peters, instructor
Steven Yates, prof



Univ Dallas

Sally Hicks, prof

UNIVERSITY
OF DALLAS

Mississippi State

Kofi Assumin-Gyimah, gradstudent
Stephan Vajdic, gradstudent
Ben Crider, prof



US Naval Academy

Bijan Nichols, undergrad
Jeff Vanhoy, prof



- Lab Overview
- Activities from last 3 years
- Where we are at today
- Activities for next 3 years

Special thanks to Anthony Ramirez,
currently @ LLNL.



University of Kentucky Accelerator Laboratory (UKAL)

- 7-MV single-ended Van de Graaff accelerator
- p, d, ^3He and α beams
- pulsed and bunched beam:
 - $f = 1.875$ MHz and $\Delta t \sim 1$ ns
- primarily conducts neutron-induced reactions and scattering experiments



Basic Nuclear Science

- Nuclear structure via $(n, n'\gamma)$
 - Level Schemes and Transitions
 - Spectroscopic Information
 - DSAM Lifetimes

Applied Nuclear Science

- Cross section measurements
 - (n, n') - Elastic and inelastic cross sections
 - ^{23}Na , ^{56}Fe , ^{54}Fe , ^{12}C , $^{\text{nat}}\text{Si}$, $^{\text{nat}}\text{Li}$
 - $(n, n'\gamma)$ - γ -ray production cross sections
 - Level cross sections
- Detector development

UKAL Experimental Hall

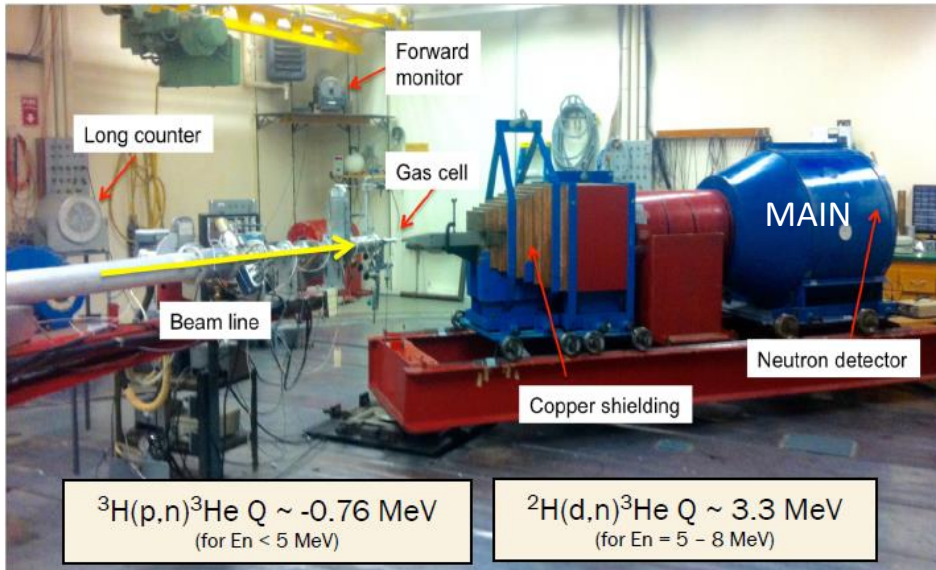

- Neutron and γ -ray detection

- time-of-flight (TOF) method to extract neutron energy spectrum
- TOF gating also employed to reduce background neutrons and γ -rays

- Angular distribution and excitation function measurements

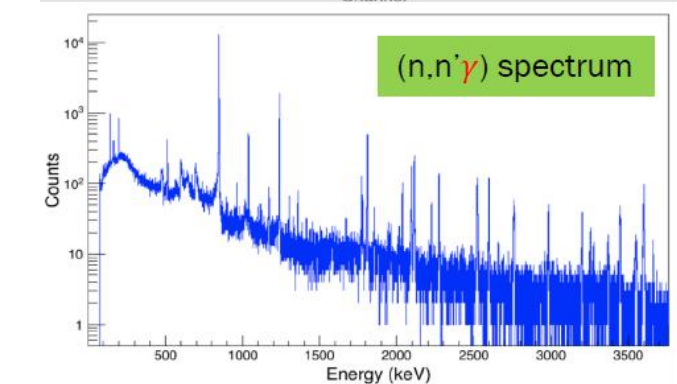
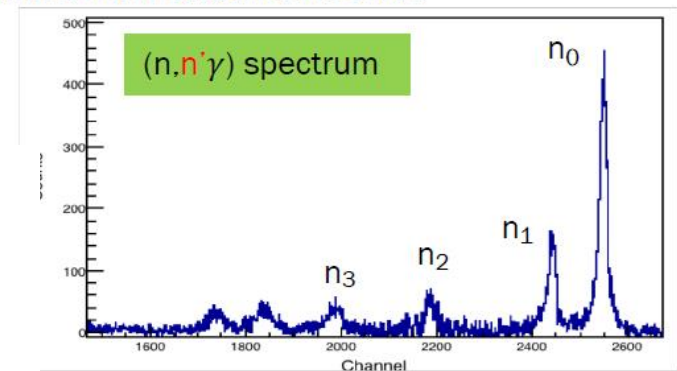

Schematic view

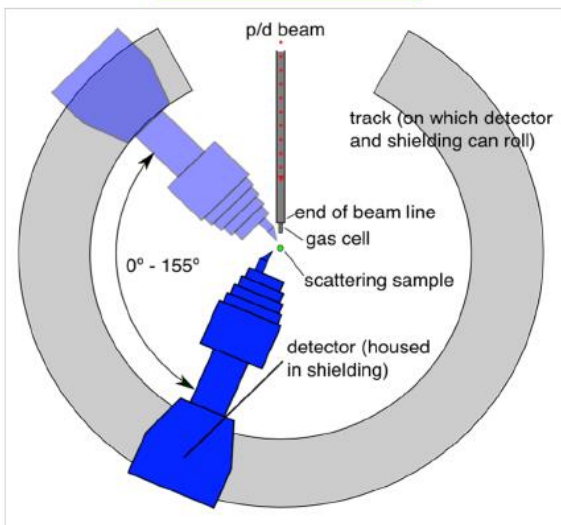

(n,n')

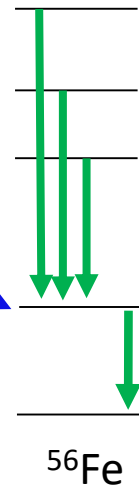

Last 3 year's Activities

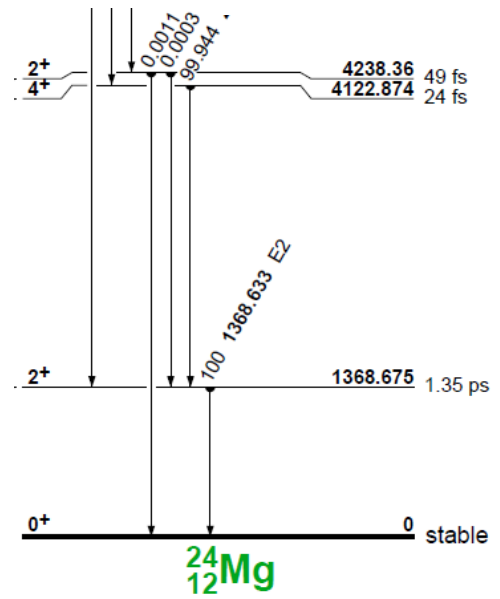
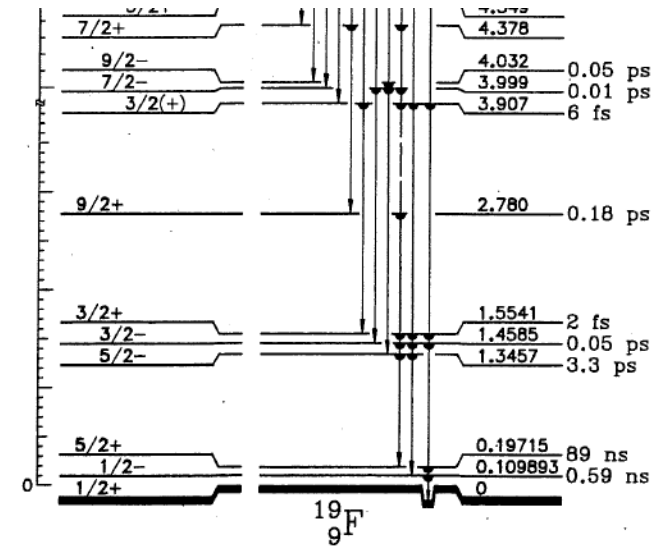
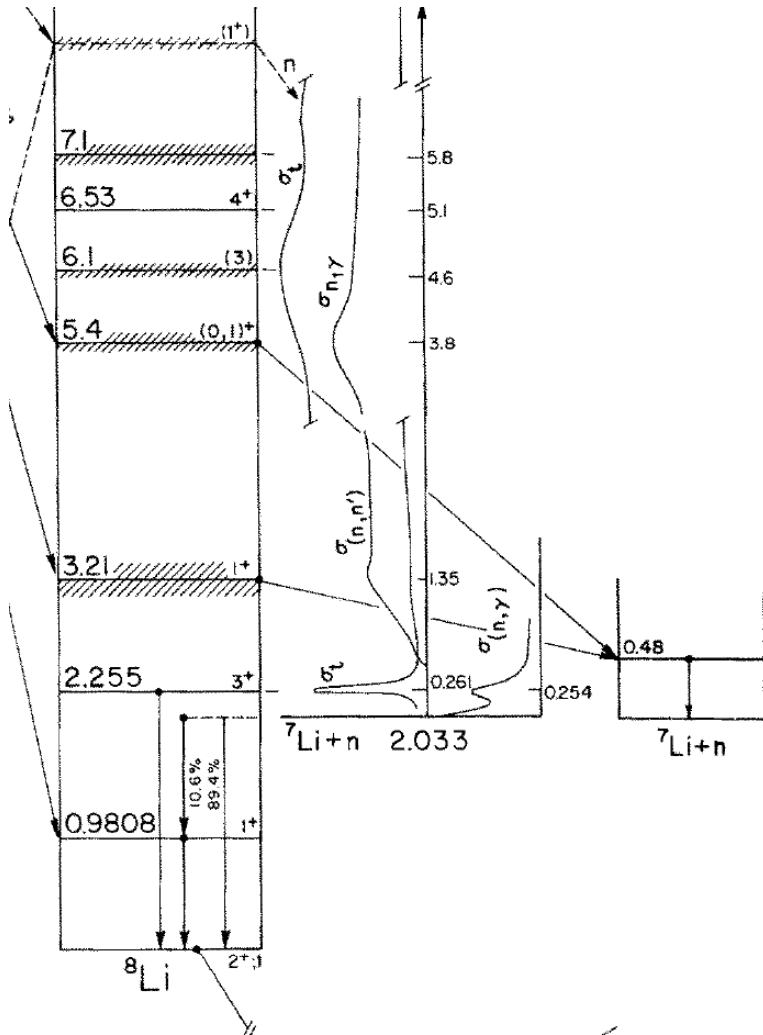

natLi

Li(n,n)

En = 3 MeV at $\theta = 130^\circ$

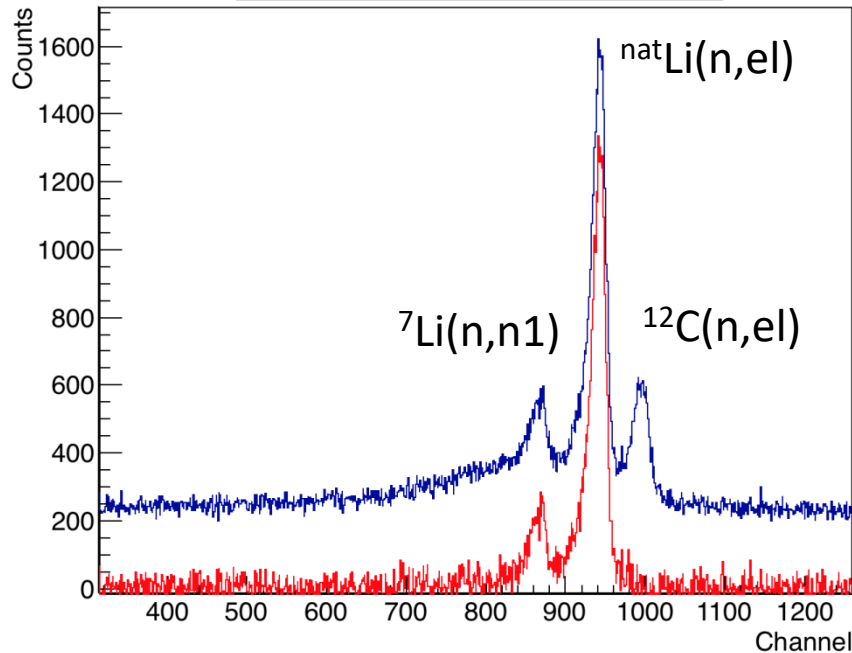

En = 3 MeV at $\theta = 40^\circ$

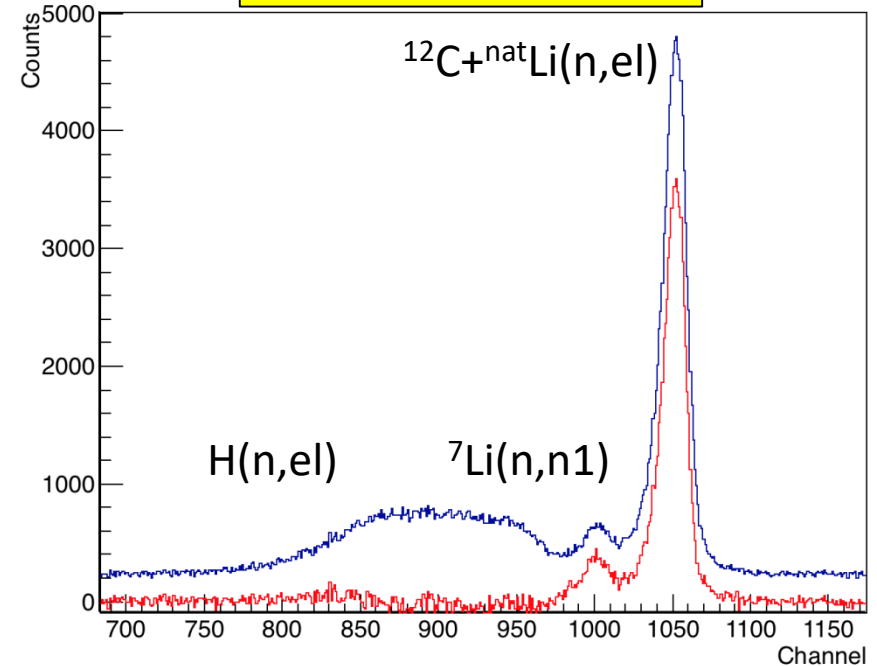

- natLi scattering sample was placed inside a polyethylene container. Hence, the additional C and H elastic peaks in the raw spectra (blue).
- Spectra subtracted with contribution by the container (red) display over subtraction due to the $\text{H}(n,el)$ bump as shown in the histogram at the right.

^{19}F Angular distribution of γ -rays from $^{19}\text{F}(n,n'\gamma)$

- a_4 values are $< |0.1|$

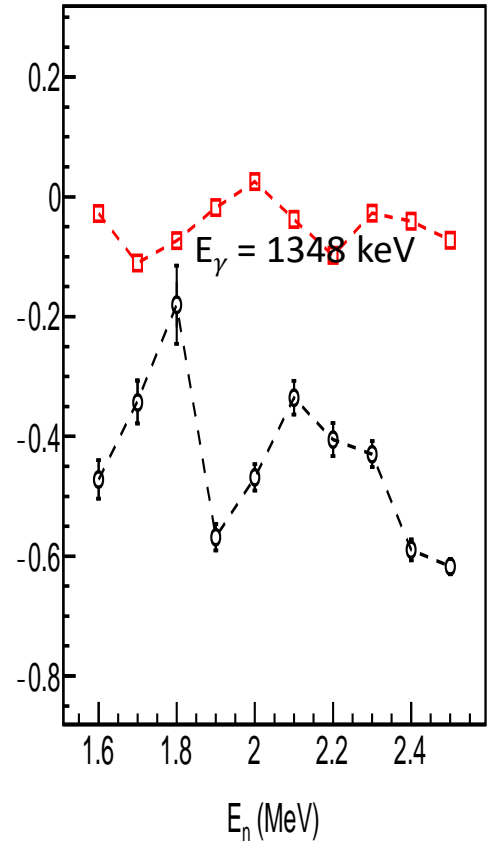
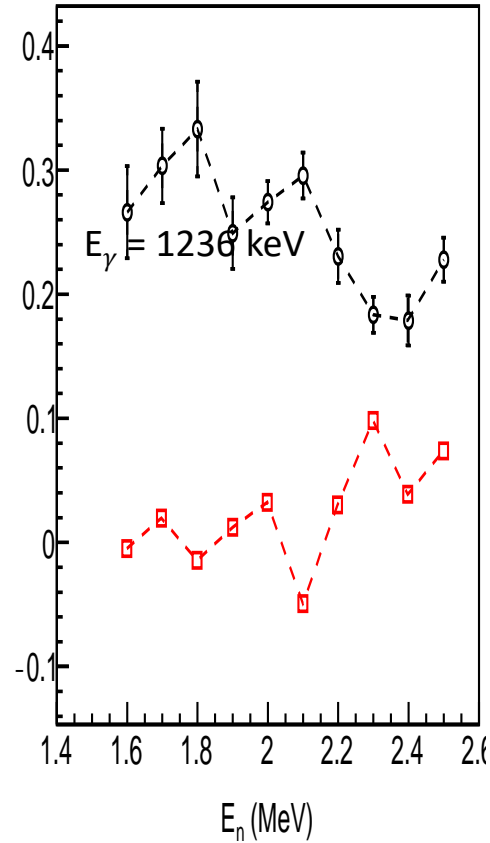
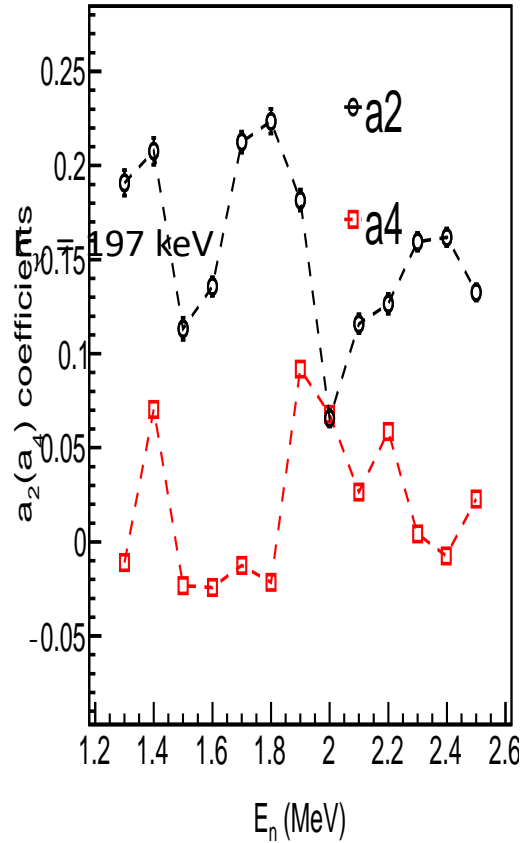
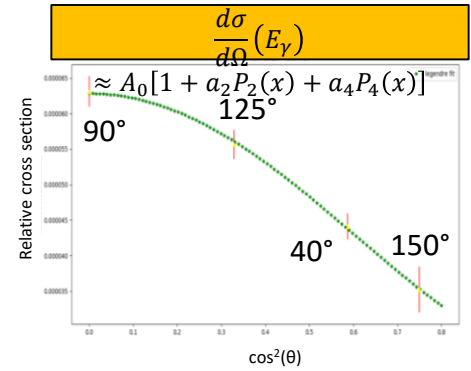

¹⁹F

➤ Deducing ¹⁹F level cross sections

1st excited → gnd

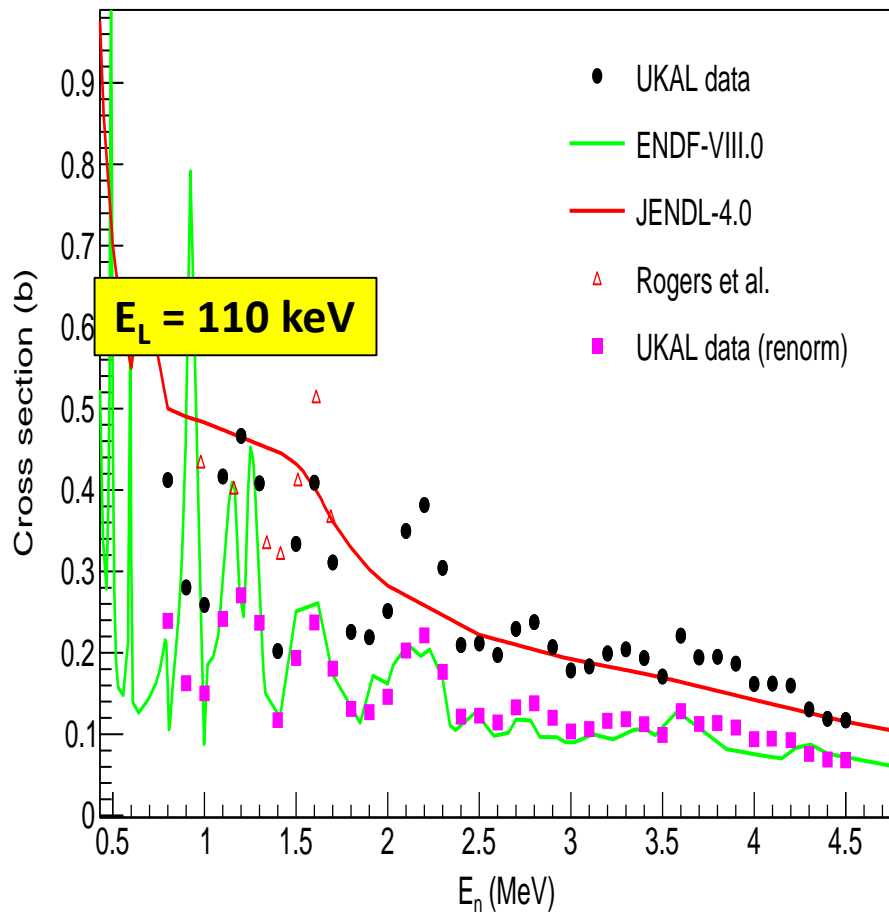

Feeding transitions

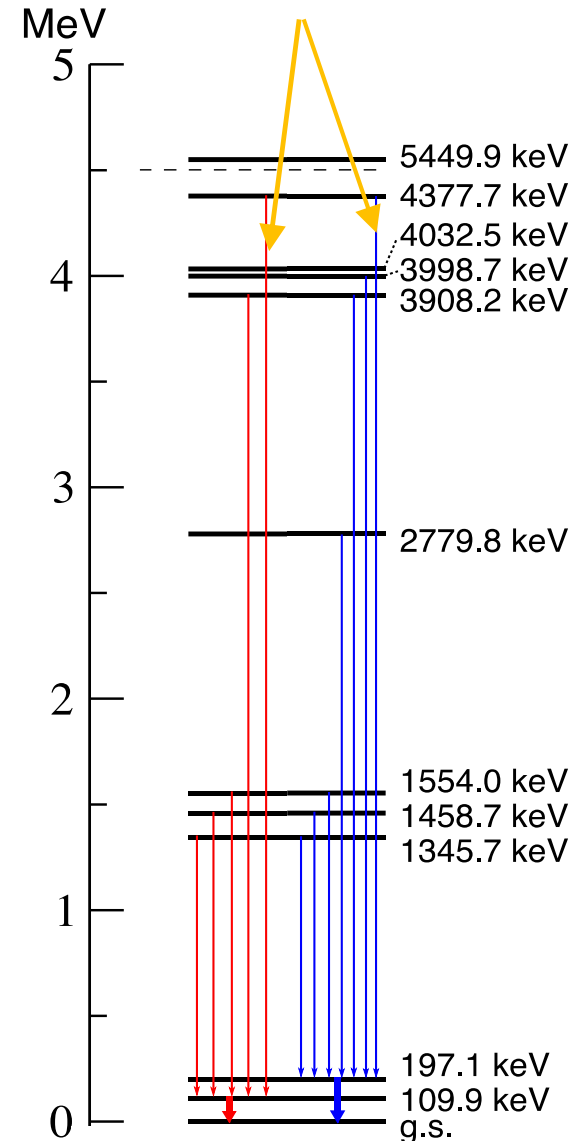

- ENDF-VIII.0 and JENDL-4.0 differ in shape and magnitude
- Our data are closer to JENDL in terms of magnitude but follow the structure presented by ENDF-VIII.0
- UKAL data (renorm) is data multiplied by arb factor so that it agrees with ENDF.

¹⁹F

➤ Deducing ¹⁹F level cross sections

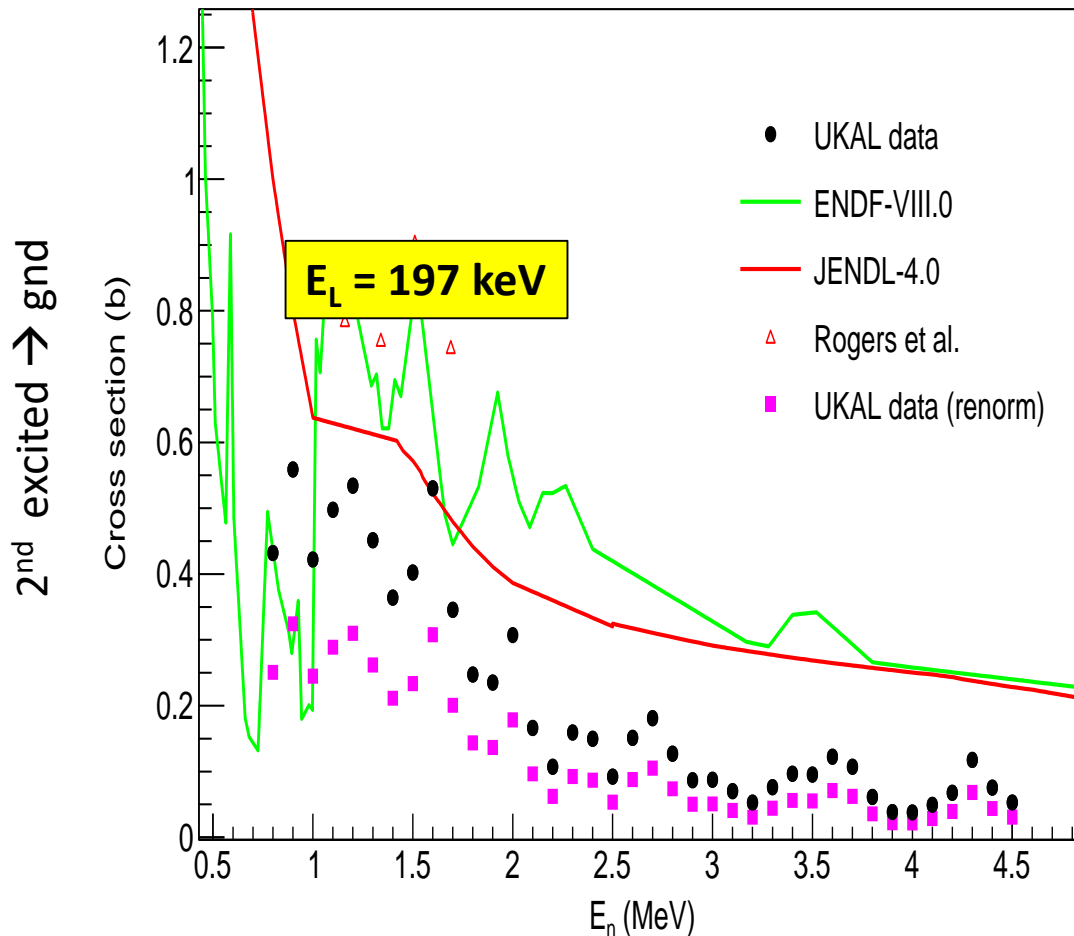

Feeding transitions

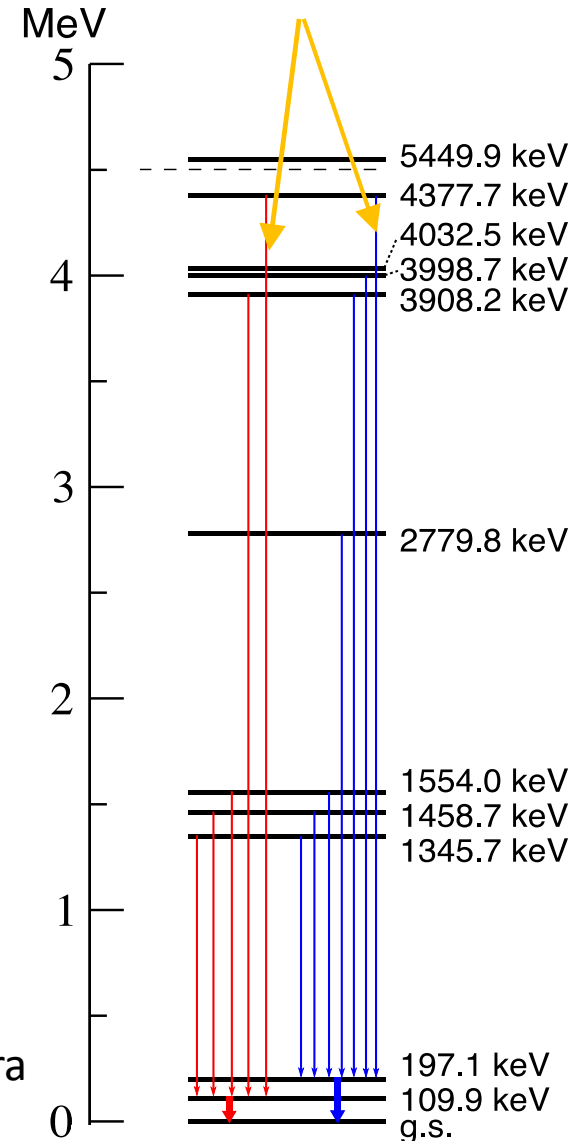

- $E_L = 197$ keV has a long lifetime with $T_{1/2} = 89.3$ ns. Our spectra were obtained by gating the TAC on the prompt γ -ray region resulting to a large discrepancy in magnitude when compared to the values in evaluation libraries.

Measurement Status

Measurements	Status
$^{\text{nat}}\text{Li}(n,n) \text{ \& } (n,n'\gamma)$	<ol style="list-style-type: none"> 1. Measured γ-ray excitation function 0.8-4.5 MeV with accompanying angular distributions in 0.1 MeV steps on LiF target. 2. Measured 2.0 & 3.0 MeV (n,n') data angular distributions on Li metal target
$^{19}\text{F}(n,n) \text{ \& } (n,n'\gamma)$	<ol style="list-style-type: none"> 1. Measured γ-ray excitation function 0.8-4.5 MeV with accompanying angular distributions in 0.1 MeV steps on LiF target. 2. Measured a trial LiF(n,n) angular distribution 3. May go to a CaF₂ or TaF target. Traditional target is CF. 4. The 89 ns lifetime of the 197 keV level causes huge problems in our n & γ TOF spectra. 5. Current DAQ software not equipped to take time-tagged event mode data. → Ben Crider
$^{24}\text{Mg}(n,n'\gamma)$	<ol style="list-style-type: none"> 0. ^{24}Mg is very deformed like ^{23}Na 1. Measured γ-ray excitation function 0.9-4.5 MeV with accompanying angular distributions . 2. a4 coefficients remain complicated
$^{\text{nat}}\text{Si}(n,n) \text{ \& } (n,n'\gamma)$	<ol style="list-style-type: none"> 1. Isotopically enriched samples not available. 2. Don't appear to be learning anything from the data we took.

Lessons Learned

- $n + {}^{\text{nat}}\text{Li}$
 - ENSDF & R-matrix CN descriptions seem inconsistent.
 - Must take isotopic data, samples waiting to be ordered.
 - There are 2 'experimental' shapes to the $\sigma_{(n,n1)}$ threshold.
- $n + {}^{19}\text{F}$
 - The 89 ns 2^{nd} excited level wreaks havoc on measurements b/c counts dribble out of the TOF spectrum.
 - New digital DAQ required so can measure time dependence of γ -ray events.
- $n + {}^{24}\text{Mg}$
 - $(n,n'\gamma)$ a_4 coefficients can be large, therefore can't trivially extract (n,n_k) cross sections from γ -ray data unless ang distrib measured.
- .

Where we are at today

Today's Status

- DOE-NP Funded for Next 3 years
 - All 4 school waiting for funds to become active
 - UD, USNA, MS State official start 1 Sept
 - UnivKY official start 1 Dec
 - MS State has functioning money.
 - Collaboration holding weekly mtgs
 - New DAQ quotes -- ready to order
 - COVID restrictions prevent major runs
- Hired postdoc Yongchi Xiao
 - Hired from other funds (started 1 Oct)
 - Learning/developing γ -ray data analysis procedures in ROOT
- Recruited Students
 - Undergrad: Bijan Nichols
 - Gradstudents: Kofi Assumin-Gyimah, Stephan Vajdic
- Lee Bernstein, LBL
 - Perhaps sending students to help during summer.
- $^{110,111,112,113,114}\text{Cd}(n,\gamma)$ measurements at DANCE completed !

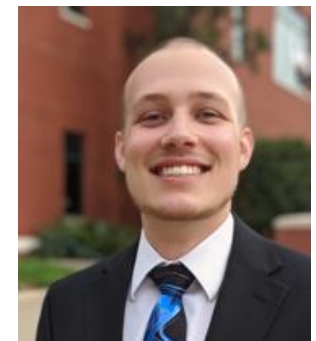

$^{110,111}\text{Cd}(n,\gamma)$ @ DANCE

14days in Sept2020

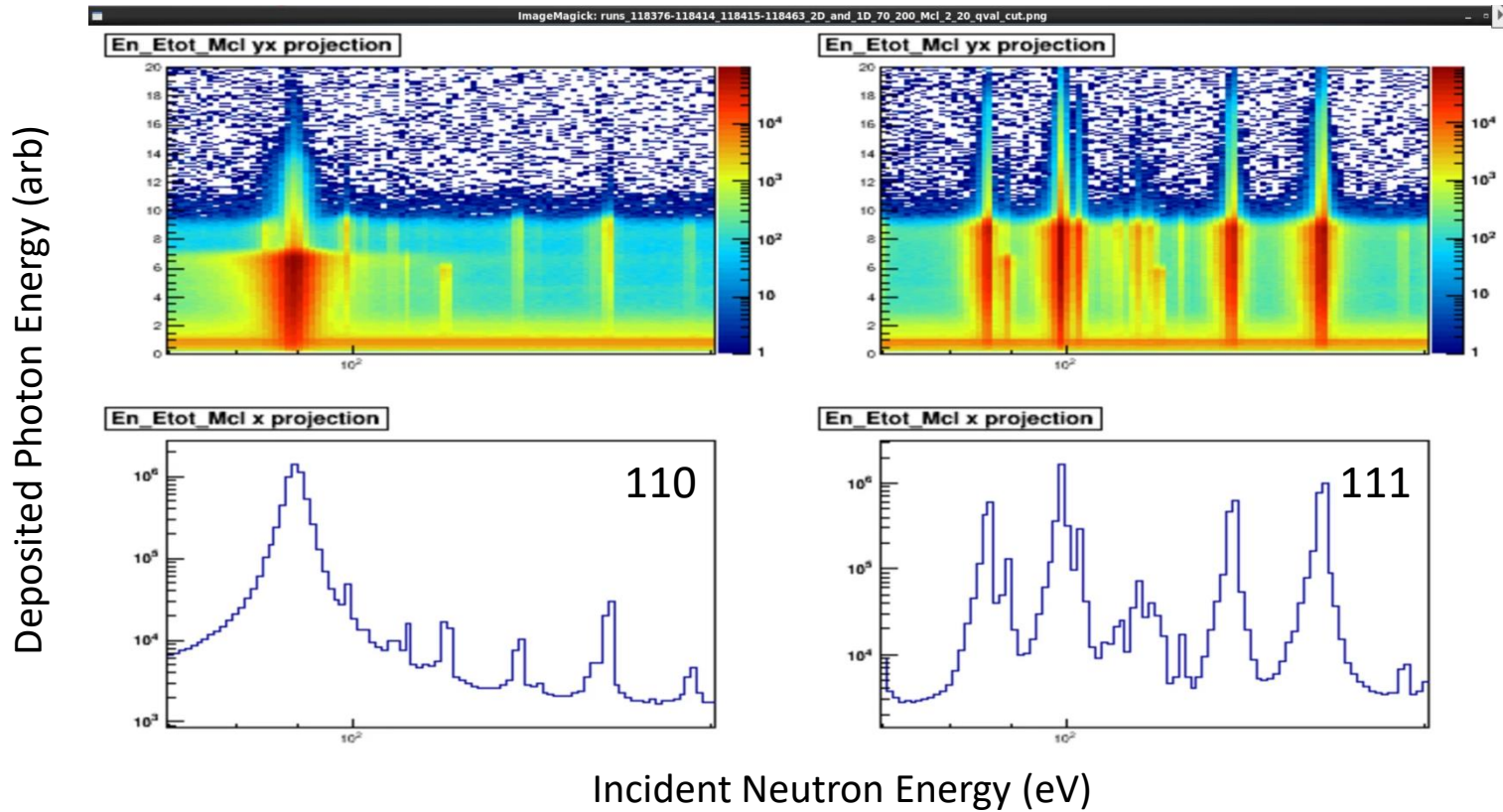

Step 1: Convert to XS

Step 2: Extract γ -ray strength function



Kofi

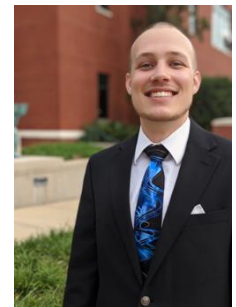

Stephan

New Postdoc, New Data Acquisition System



Yongchi

DAQ



Calibration Lines

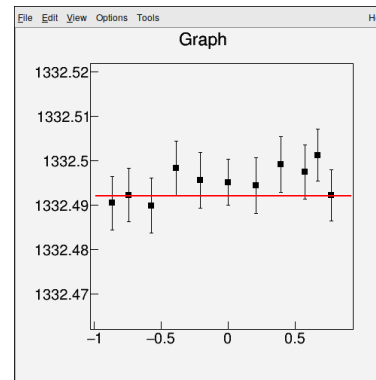
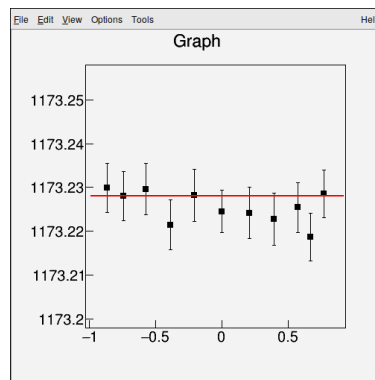
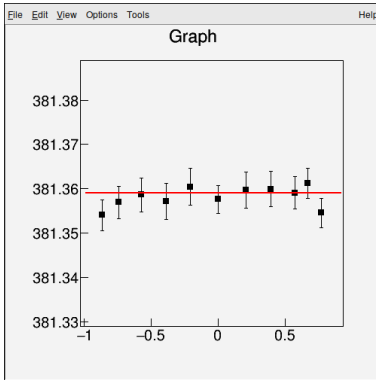

Xe Lines w
Doppler Shifts

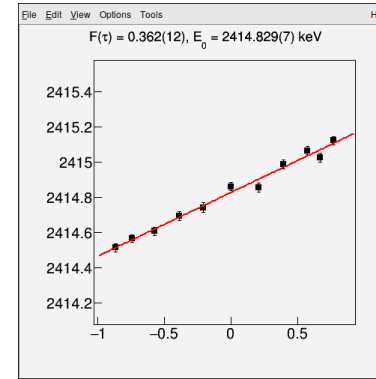
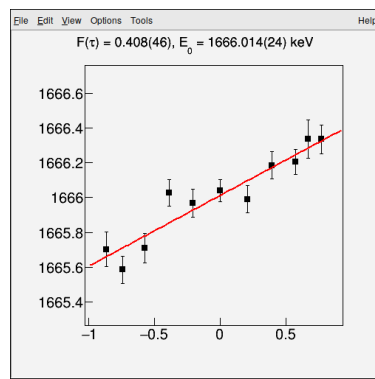
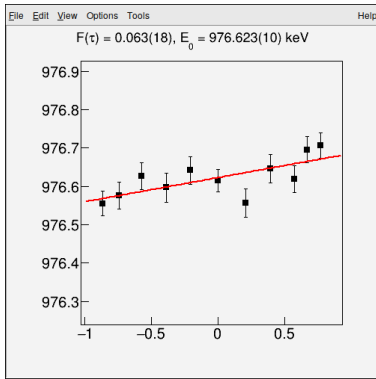

Until the DAQ system arrives, YX trying to use ROOT to fit "Kentucky data"

Next 3 years

Primary Projects

$^{12}\text{C}(n,n')$

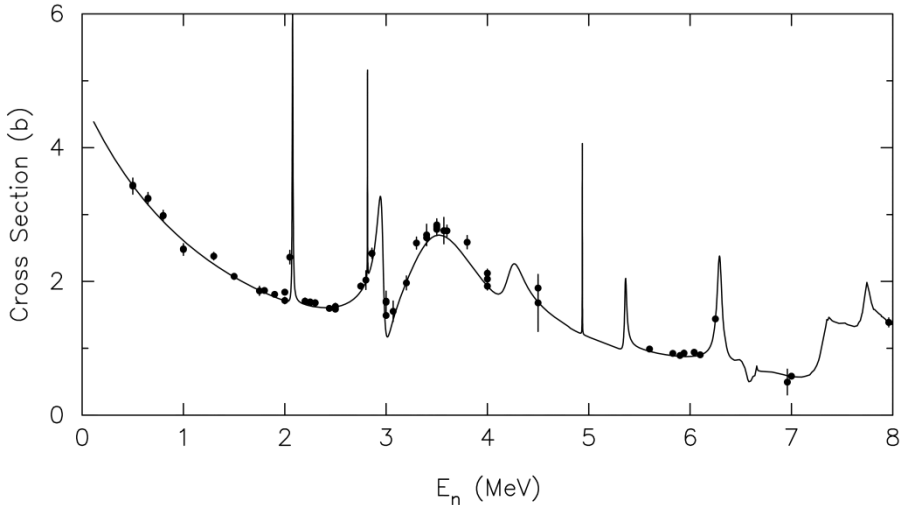

Fig. 1. The ENDF8 [11] angle-integrated $^{12}\text{C}(n,n)$ cross sections; data are from previous UKAL measurements.

4-6 additional ang distrib measurements in the range 5-8 MeV to assist with resonance parameters.

Are there problems down at 100-300 keV we should measure?

Have request for back-angle measurements at and just above 1 MeV.

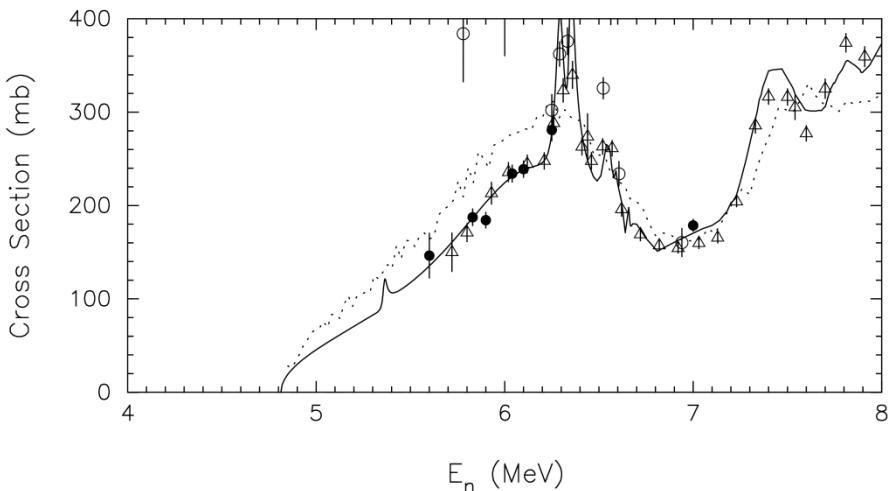
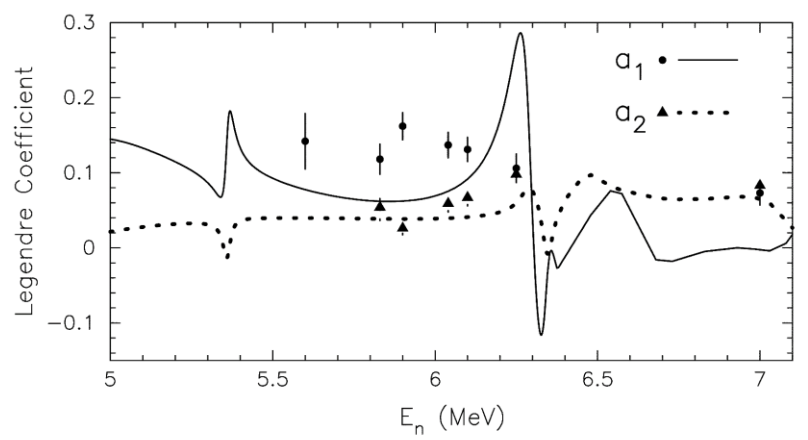
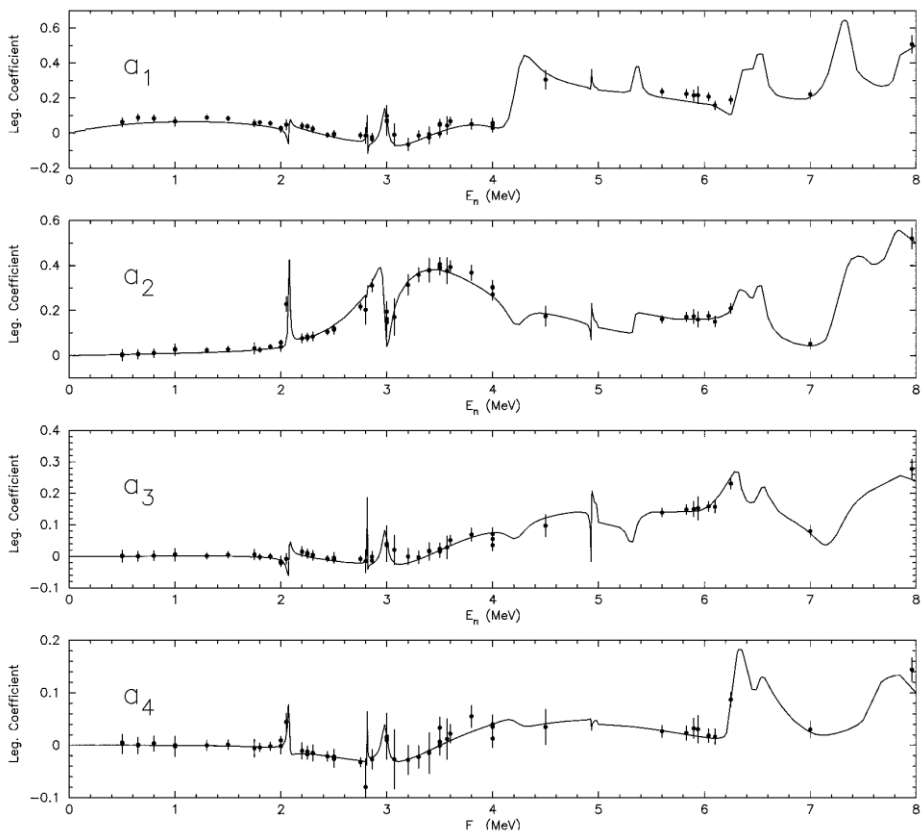

Fig. 2. The ENDF8 angle-integrated $^{12}\text{C}(n,n_1)$ cross section annotated with previous experimental measurements found in EXFOR. UKAL data are given by blackened circles.

Carbon Elastic Legendre Coefficients: Results vs ENDF

$$W(\theta) = A_0 \sum_L a_L P_L(\cos \theta) \quad ; a_0 = 1$$

$$a_L^{ENDF} = \frac{a_L^{exp}}{2L + 1}$$



→ Elastic agreement is very satisfying.

Agreement with ENDF coefficients is not so satisfying.

→ Describing (n,n₁) is difficult

Primary Projects

${}^7\text{Li}(n,n_k)$ and $(n,n'\gamma)$

We need isotopic samples to generate useful information.

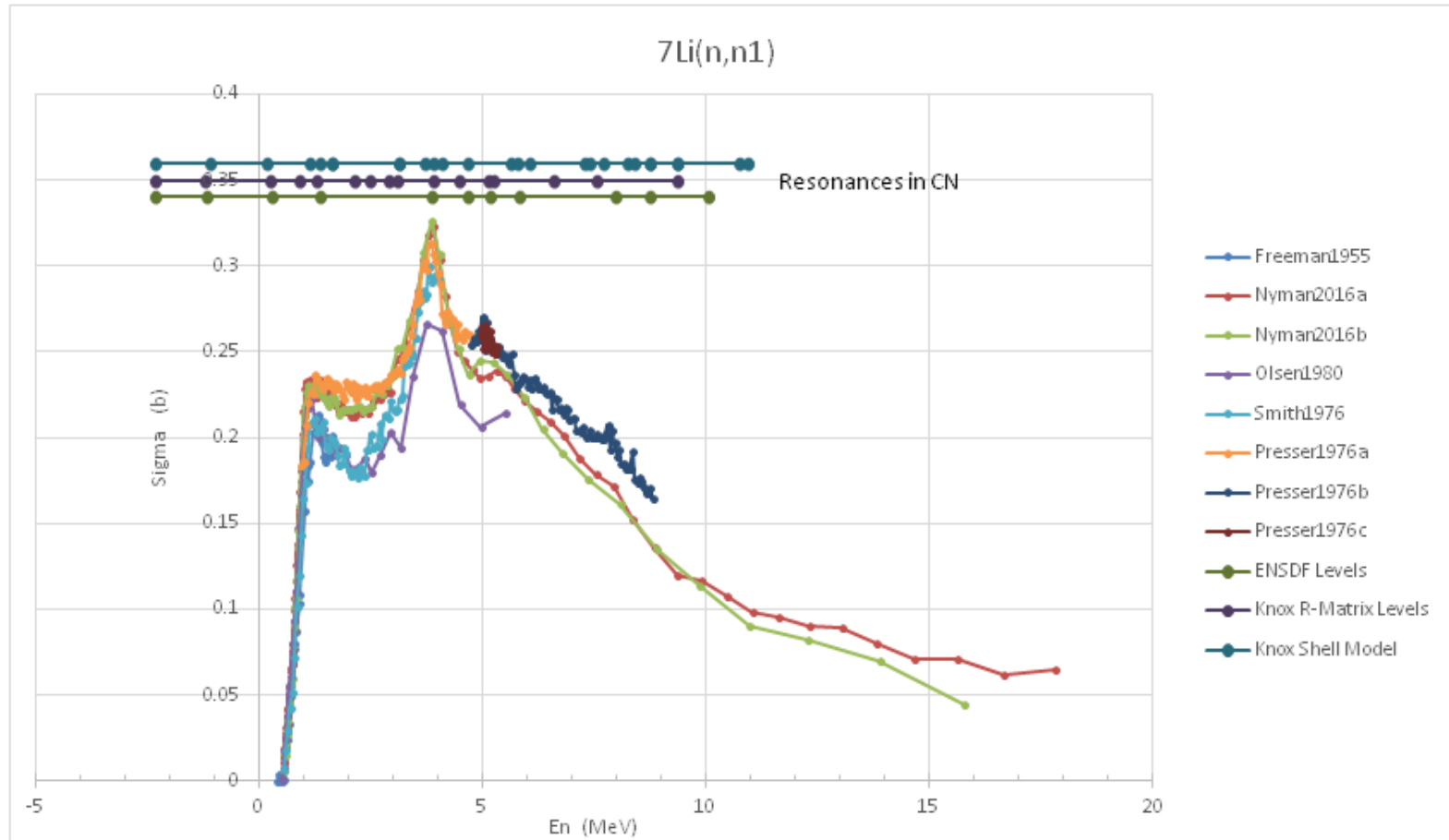

Fig. 3. Measured / inferred ${}^7\text{Li}(n,n_1)$ cross sections from EXFOR compared to two R-matrix calculations. The position of the resonances are indicated along with the adopted levels of the ${}^8\text{Li}$ compound nucleus from ENSDF.

Primary Projects

$^{19}\text{F}(n,n'\gamma)$

Surprisingly few detailed neutron scattering data exist for ^{19}F . Industrial manufacturers of compact molten salt reactors employ FLiBe as a base material and have called for an increased understanding of its properties.

Cross sections in the lower portion of the fast neutron region exhibit resonances, but countable resonances disappear about 2.5 MeV. Total cross sections have been measured for ^{19}F , but few experimental angular distributions exist. This is a problem for R-matrix reaction model analysis because the ^{19}F ground state is $J\pi = 1/2^+$, and, therefore, at least two partial widths are involved in the formation and decay of the compound nucleus.

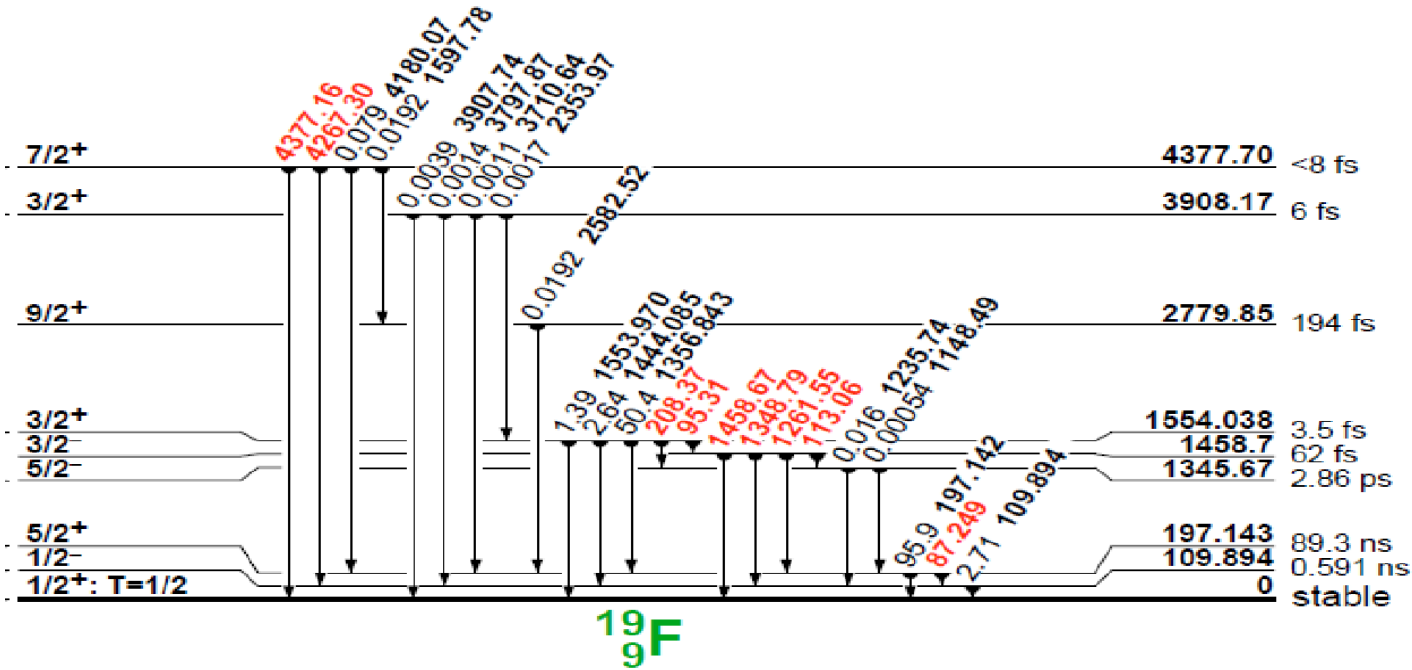

As mentioned previously, the 89 ns isomer causes a lot of trouble.

Secondary Projects (only if we have time)

Sodium-23 is a component in
Measurements below 1.3 MeV.
More ang distrib for resonance information

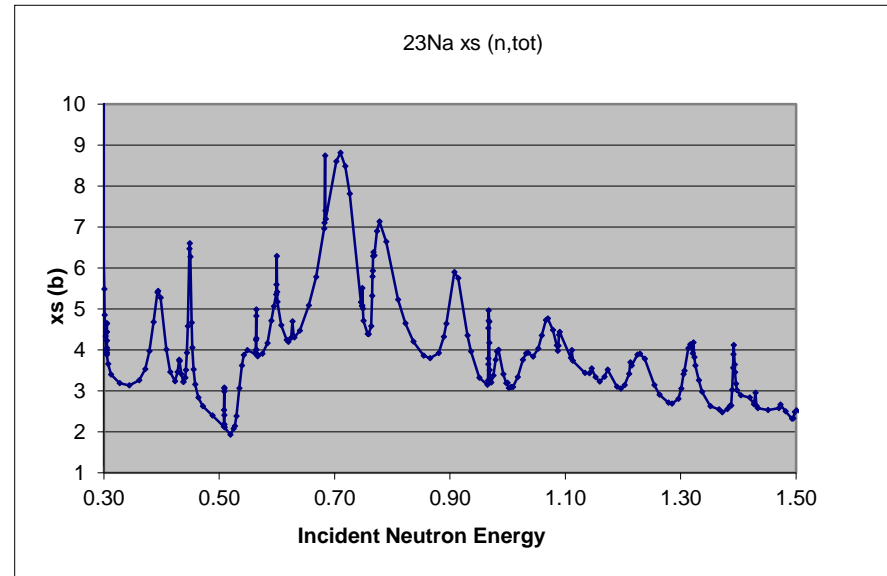

Iron-56, one of the most ubiquitous materials,
Possible addn'l measurements upon request.
Conversion of existing HE data to neutron emission spectra.

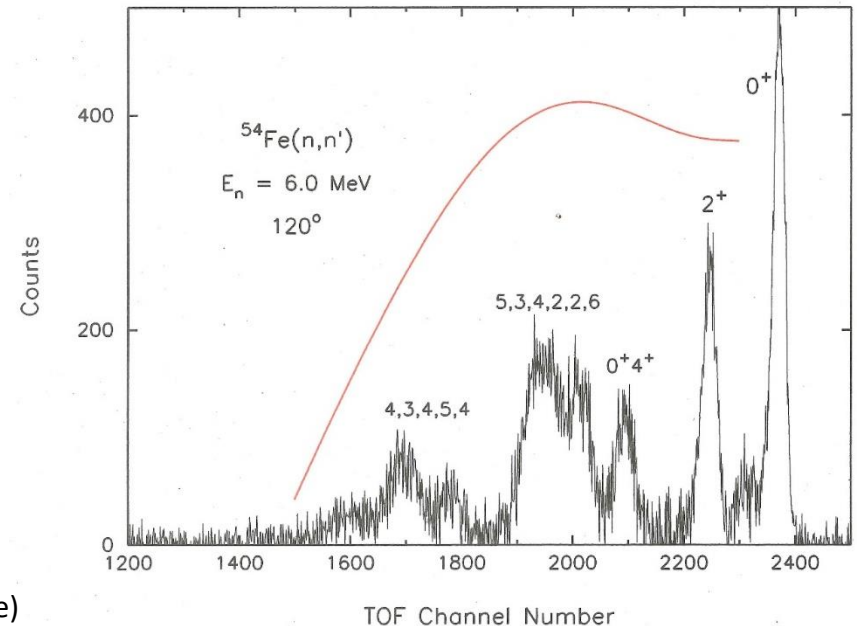

(OK, the figure is 54, but you get the picture)

Secondary Projects (only if we have time)

Conversion of Previously Measured Angular Distribution Data to Differential Cross Sections.

The active interrogation community is aware that much $(n,n'\gamma)$ data for nuclear structure purposes have been measured at UKAL.

The list includes most major stable isotopes of the elements Na, Fe, Ge, Se, Zr, Mo, Ru, Pd, Cd, Sn, Te, I, Xe, Ba, Ce, Nd, Sm, Gd, Dy, and Er.

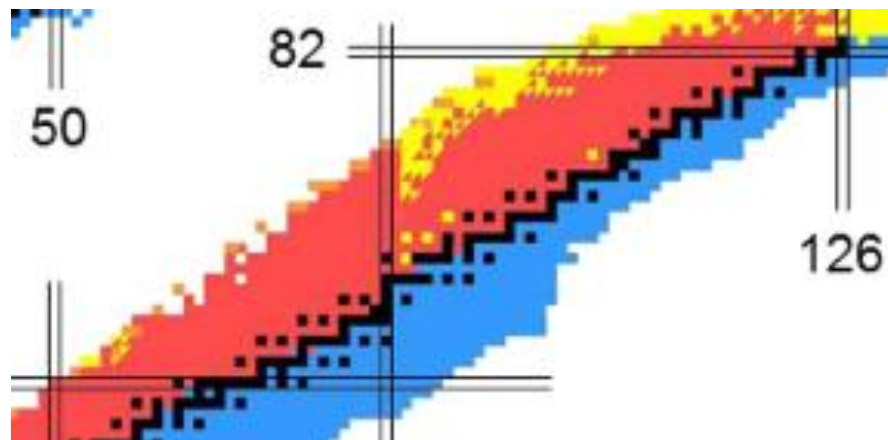

Secondary Projects (only if we have time)

n- γ Angular Correlations. The team has assisted associates at the nELBE time-of-flight facility (<https://www.hzdr.de/db/Cms?pNid=35>) with n- γ angular correlation calculations and have been encouraged to submit beamtime proposals for targets of common interest (^{56}Fe , ^{28}Si , ^{54}Fe). Such measurements have the potential to improve the precision of our γ -ray production cross sections. We have not taken advantage of the offer due to a lack of travel funds, but have provided advice on the angular positioning of the γ -detectors as they have little experience with detailed angular distributions. We would like to maintain contact for joint investigations in the distant future if the opportunity presents itself again.

Neutron emission spectra.

In the High Priority Request List [1], the fast reactor design community has requested emission spectra for neutron inelastic scattering on ^{23}Na and ^{56}Fe between 0.5 and 20 MeV incident energy and on ^{238}U between 65 keV and 20 MeV. The laboratory GELINA has made precise measurements of the γ -ray emission spectra of these nuclei; however, that laboratory does not have the capability to determine the emitted neutron energy.

Neutron capture.

The team has also been repeatedly asked to participate in (n, γ) measurements at the Institute Laue-Langevin. However, those experiments tend to be basic research instead of satisfying applied interests of the US government programs. The ILL FIPPS array employs high resolution HPGe detectors but with a continuous neutron beam. The DANCE array at LANL employs low resolution BaF₂ detectors with a pulsed neutron beam. Some team members would like the option to participate in some limited capacity, should funds be available.

$\text{CdTe}(n,\gamma)$ $^{100}\text{Ru}(n,\gamma)$ -- awaiting rescheduling

SUMMARY:

Much to do.

Have identified the students.

Must travel to take data and efficiently collaborate.

END

END

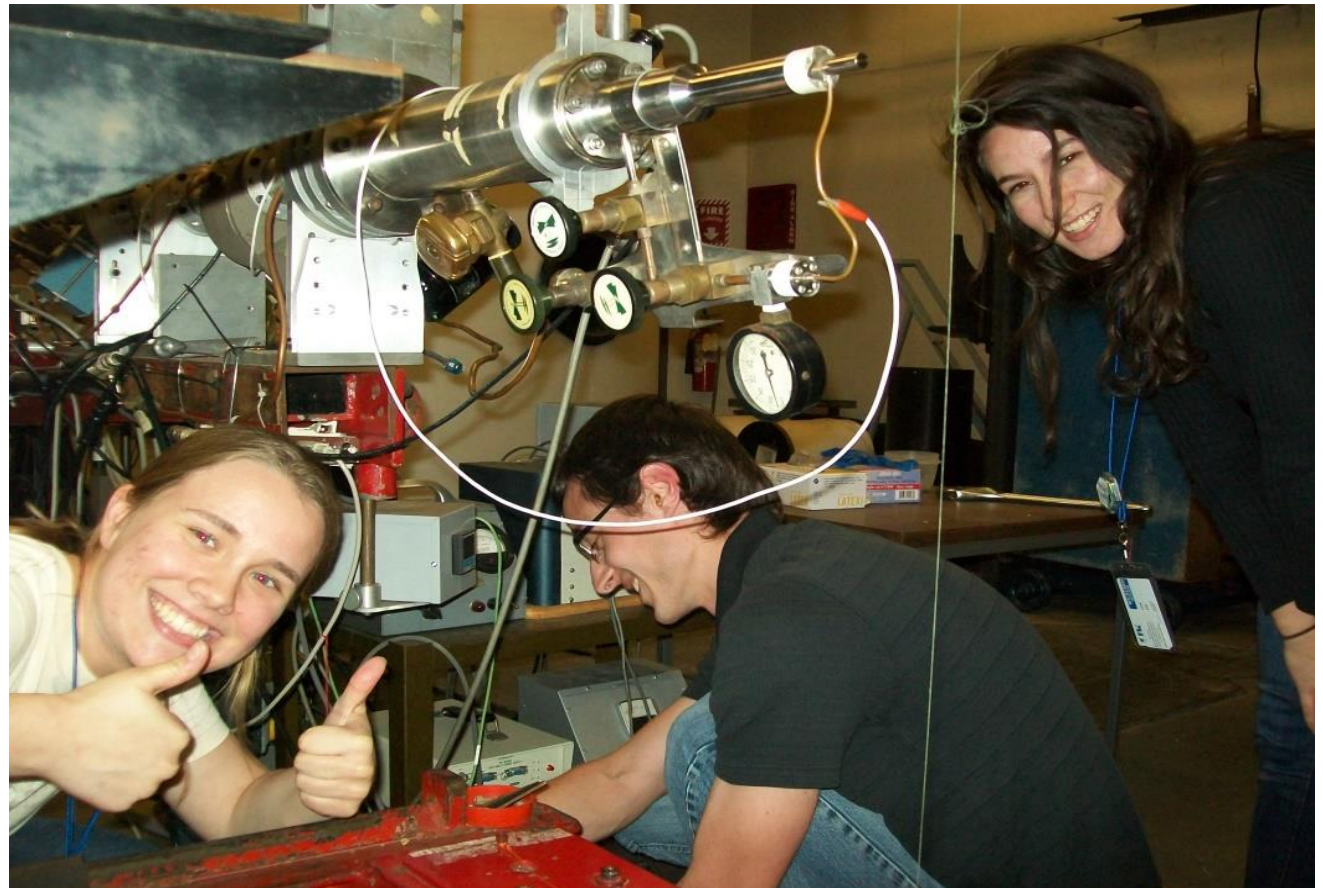

Uncertainties in Angular Distribution Values

Issue	
Counting Statistics n_0, n_1	<1%
Ability to Extract Yield from Peaks in Spectra (elas)	~2% usually
Ability to Extract Yield from Peaks in Spectra (inel)	...hum
Monitoring Neutron Production	<1%
Sample Mass	<<1%
H(n,n) reference XS	<0.5%
Detector Efficiency	
3H(p,n) $d\sigma/d\Omega$	~3%

Issue	
Atten & Mult Scat	
$n\sigma$	0.3 %
sample radius	0.3 %
sample-Tcell dist	0.2 %
method	<5%

making new MCNP tests with improved gas cell description to make this more definite

depends on the target nucleus

- Overall during ^{23}Na runs:
 - elastics ~8-10%
 - inelastics ~13-18%

- Overall during $^{54-56}\text{Fe}$ runs:
 - elastics ~7-10%
 - inelastics ~10-14%

**Overall during C runs: elastics ~6%
inelastics ~10%**

