

Tracing the Boundary of Ordinary Matter

Exploration of the QCD Phase Diagram at RHIC

Berndt Mueller (Duke University)
RHIC-BES Seminar
April 13, 2021

Overview

- The RHIC Beam Energy Scan II
- Critical Point search
- RHIC beyond BES-II

Beam Energy Scan II

RHIC: A Unique Facility

- RHIC is the world's most versatile facility for the exploration of the phases of QCD matter from high temperature to high baryon density.
- It's ability to explore hot QCD matter at high net baryon density has been enhanced by the installation of low-energy electron cooling (LEReC - 2020) and the upgrades of the STAR detector (iTPC, EPD, FTOF, FXT - 2018/19).
- These upgrades enable high-rate data taking down to 7.7 GeV CM energy in collision mode and to 3.0 GeV CM energy in the fixed target mode.
- RHIC/STAR is now able to collect data samples of > 100 million minimum bias events for Au+Au collisions over the entire CM energy range from 3.0 GeV to 200 GeV.

RHIC Runs 2018 - 2021

- **Run 2018:**

- High statistics 200 GeV isobar system ($^{96}\text{Ru} - ^{96}\text{Zr}$) comparison run
- 27 GeV Au+Au
- 3.0 GeV Au+Au (fixed target)

- **Run 2019:**

- 1st year of high statistics Au+Au beam energy scan ($\sqrt{s_{\text{NN}}} = 7\text{--}20$ GeV)
- Collider mode: $\sqrt{s_{\text{NN}}} = 14.6, 19.6, 200$ GeV
- Fixed target mode: $\sqrt{s_{\text{NN}}} = 3.2$ GeV (200M events)

- **Run 2020:**

- 2nd year of high statistics Au+Au beam energy scan
- Collider mode: $\sqrt{s_{\text{NN}}} = 9.2$ GeV (162M ev.), 11.5 GeV (235M ev.)
- Fixed target mode: $\sqrt{s_{\text{NN}}} = 3.5, 3.9, 4.5, 5.2, 6.2, 7.2, 7.7$ GeV (>100M ev.)

- **Run 2021:**

- 3rd year of high statistics Au+Au beam energy scan
- Collider mode: $\sqrt{s_{\text{NN}}} = 7.7$ GeV (goal: 100 M events)

RHIC & the QCD Phase Diagram

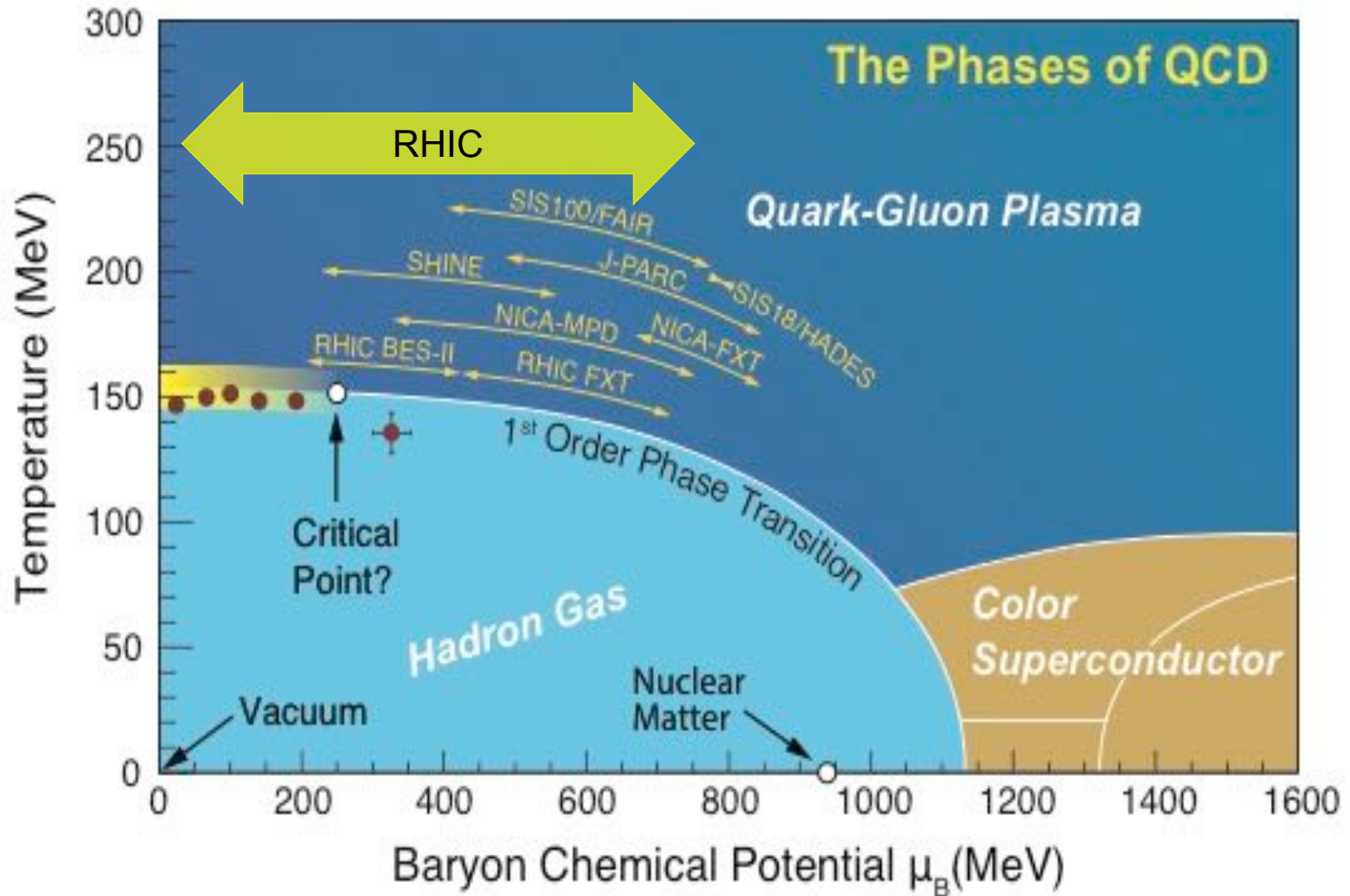

Charting the Boundary

Experimental evidence
for the QCD phase boundary
in 1995
Created for NSAC 1995 LRP

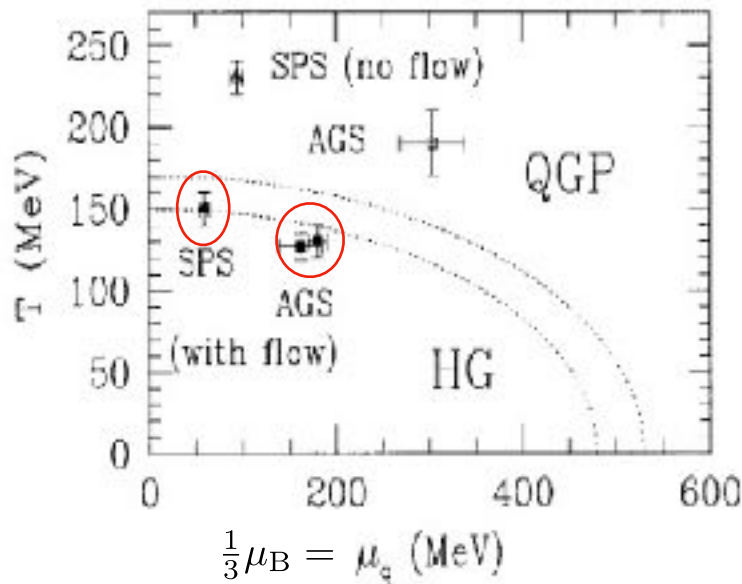

[B.M., NPA 590 (1995) 3c]

Phys. Rev. C96, 044904 (2017)
[STAR collaboration - BES-I data]

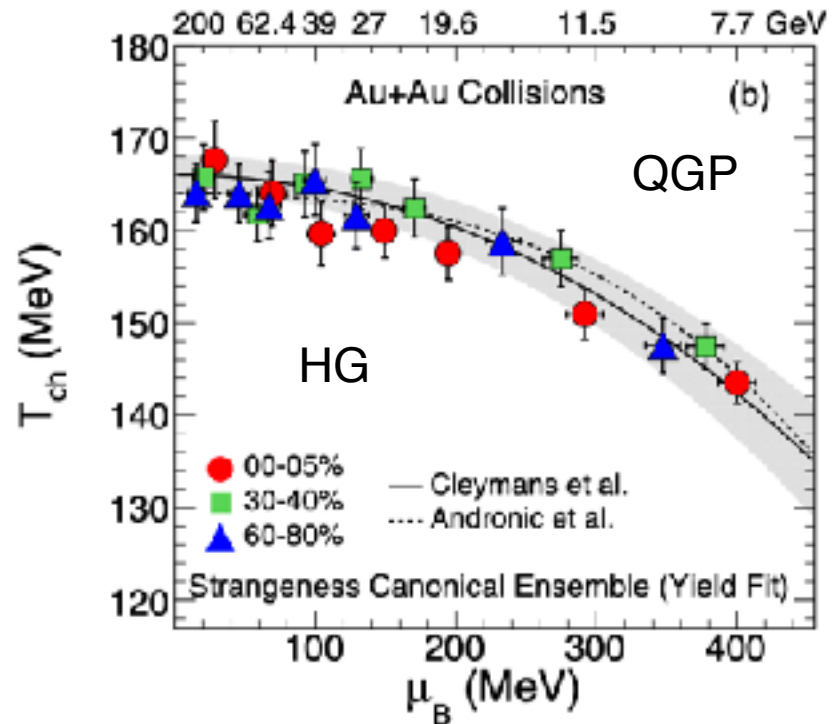

Will be extended to $\mu_B \approx 700$ MeV in the
precision beam energy scan at RHIC.

Why $\sqrt{s_{NN}} = 3-30$ GeV?

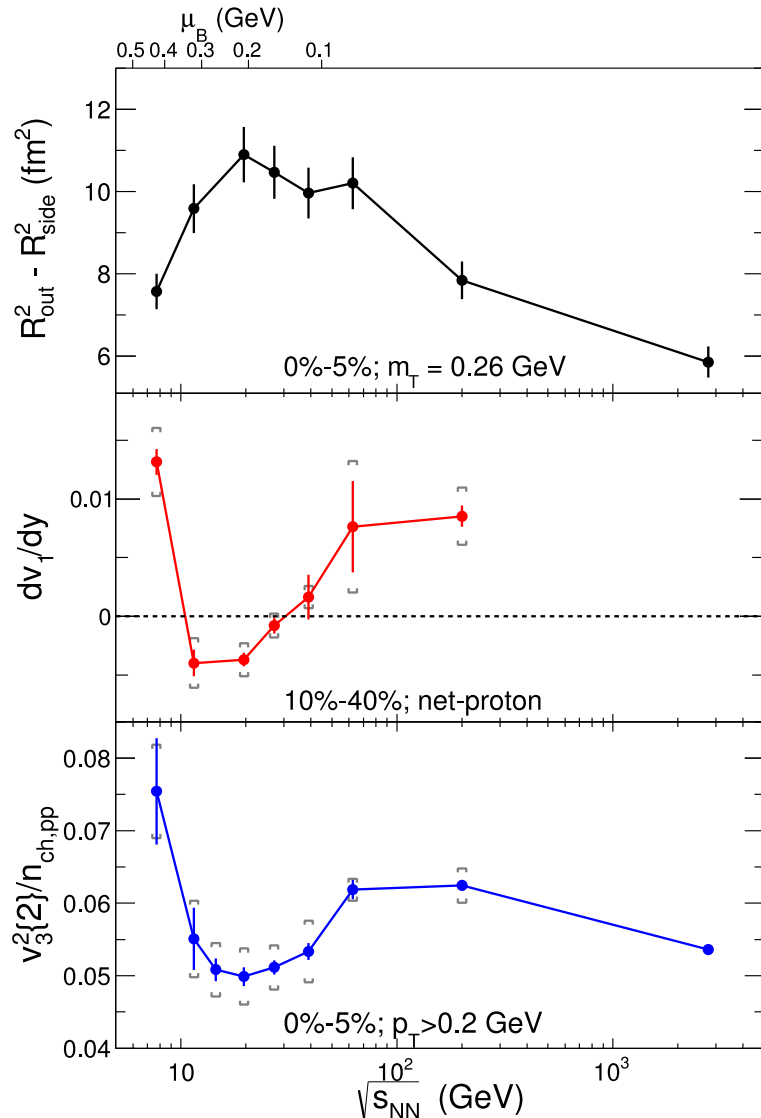

Maximum in lifetime?

Minimum in pressure?

Region of interest $\sqrt{s_{NN}} \lesssim 20$ GeV is complicated by changing B/M ratio, baryon transport dynamics, longer nuclear crossing times, etc.

Significant modeling uncertainties

RHIC: Precision Beam Energy Scan

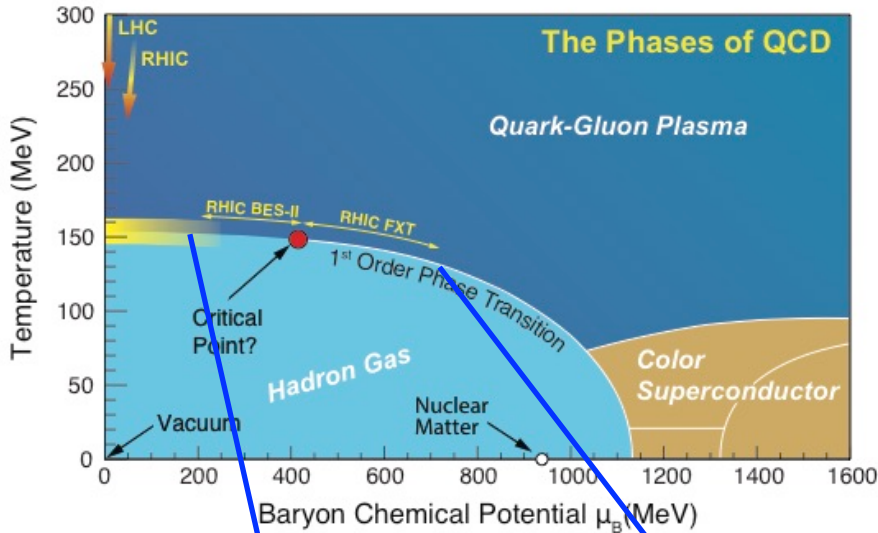

Beam Energy Scan Goals

- Where is the phase boundary of ordinary nuclear matter, i.e. matter composed of baryons and mesons?
- Is there a critical point in the QCD phase diagram and, if so, where is it located?
- 3-year run program: 13 energies (14 runs)
- 7 energies new (fixed target)
- >10-fold statistics for all energies
- **13.7 beam energy scan runs complete!**

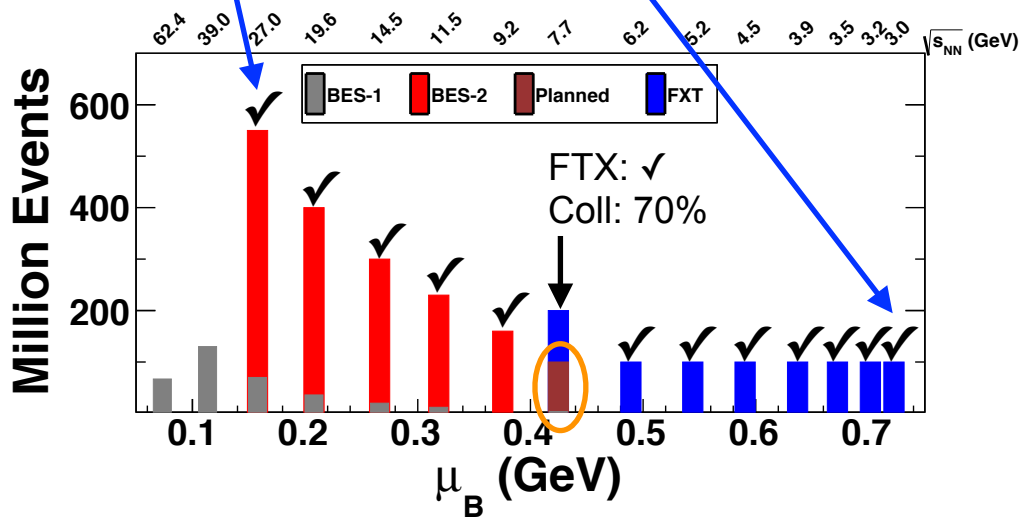

Low Energy RHIC electron Cooling
 First-ever electron cooling with bunched beams
 Test case for electron cooling at EIC



RHIC Run 21 status

Goal: 100 million minimum bias events for $\sqrt{s_{NN}} = 7.7$ GeV Au+Au collisions

Status: April 6, 2021



AuAu 7.7 GeV Collisions

- Stable performance with injection dampers (low tune);
- 60.6 (+3.2)M accumulated events for 7.7GeV collisions;
- The projections shows that we may achieve the 7.7GeV data set goal by May 3rd. (average last 2 weeks)



Upgrades for BES-II

63.9 m to IP2

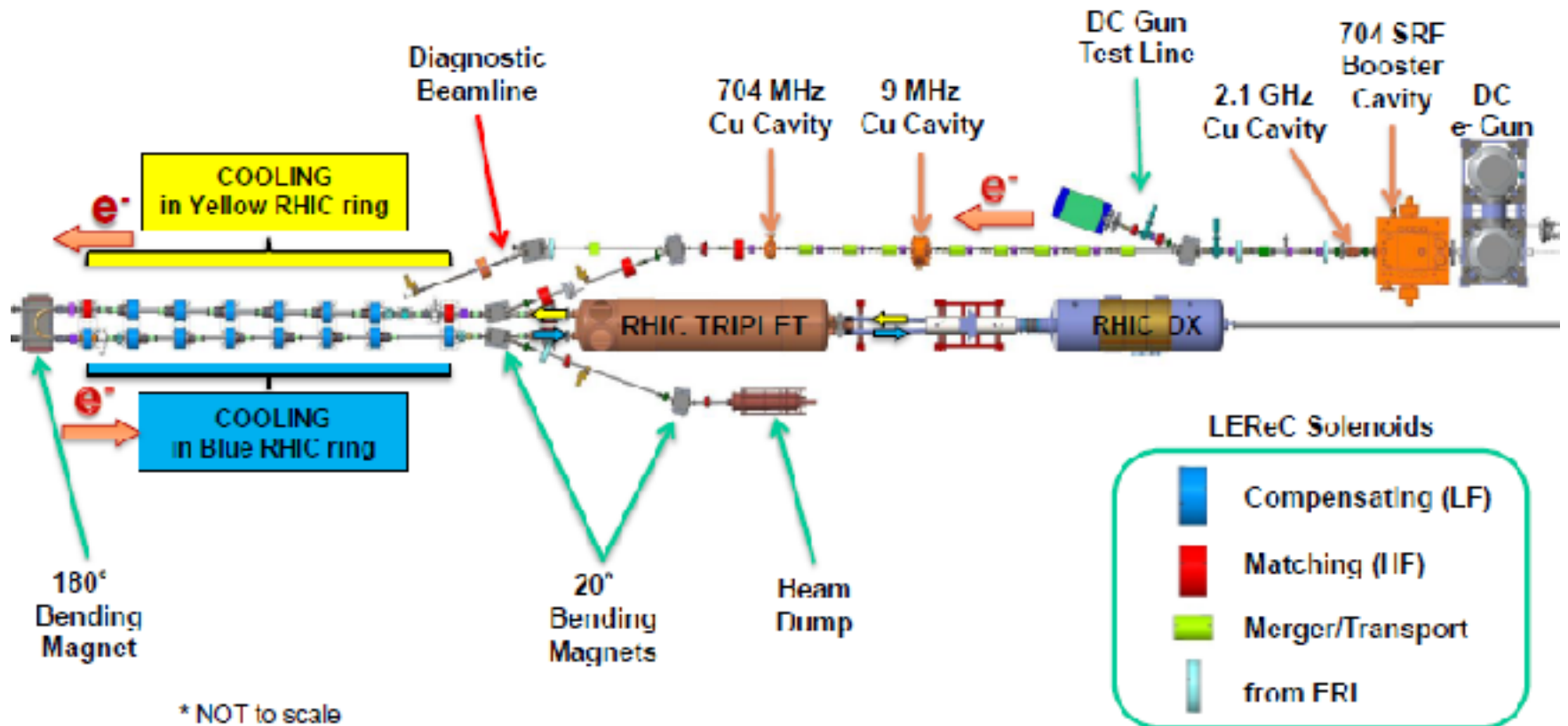

LEReC is a unique and pioneering facility, nothing similar was built before

LEReC Facility

Low-Energy RHIC electron Cooling (LEReC) facility was constructed over 5+ years

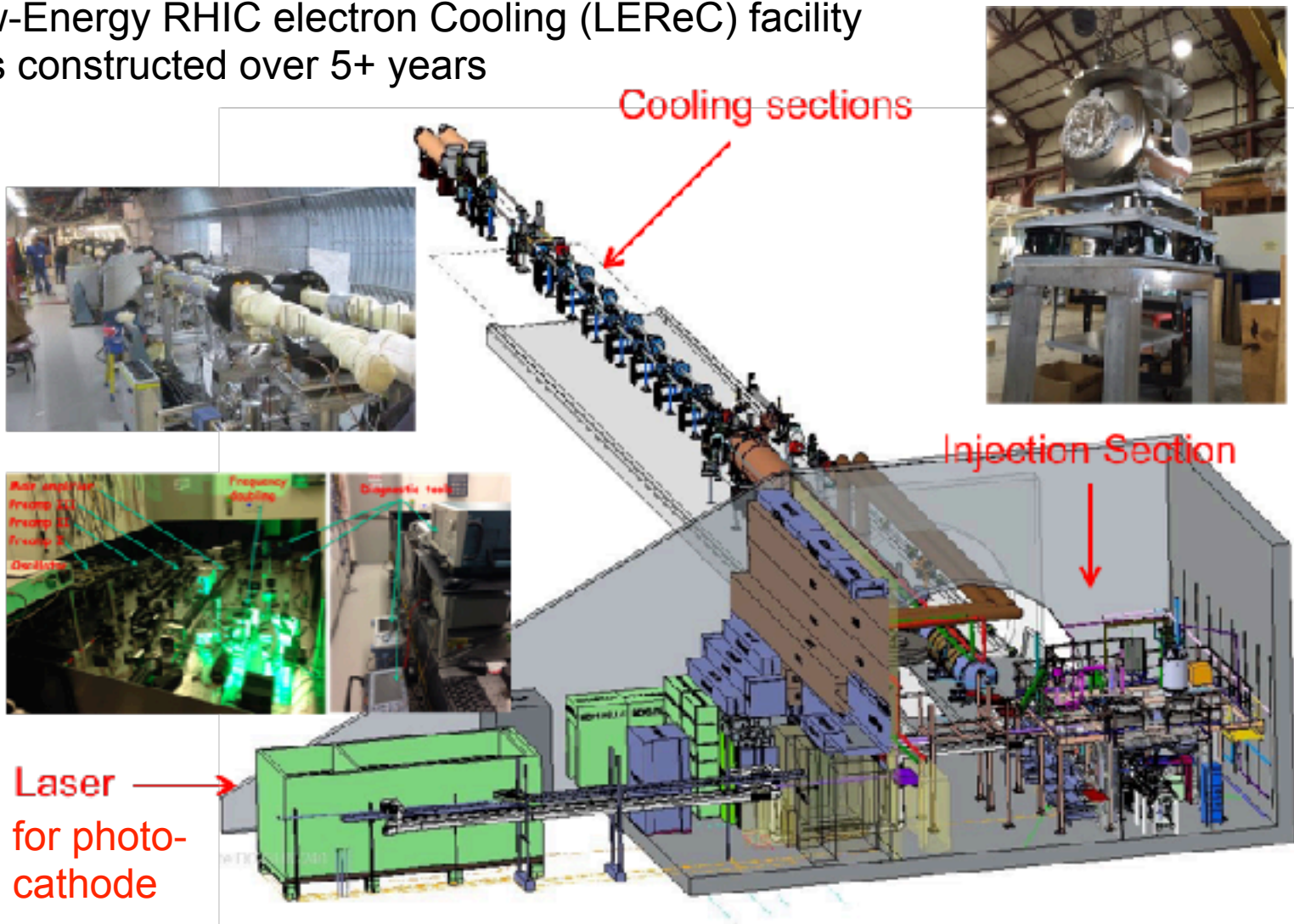

STAR upgrades for BES-II

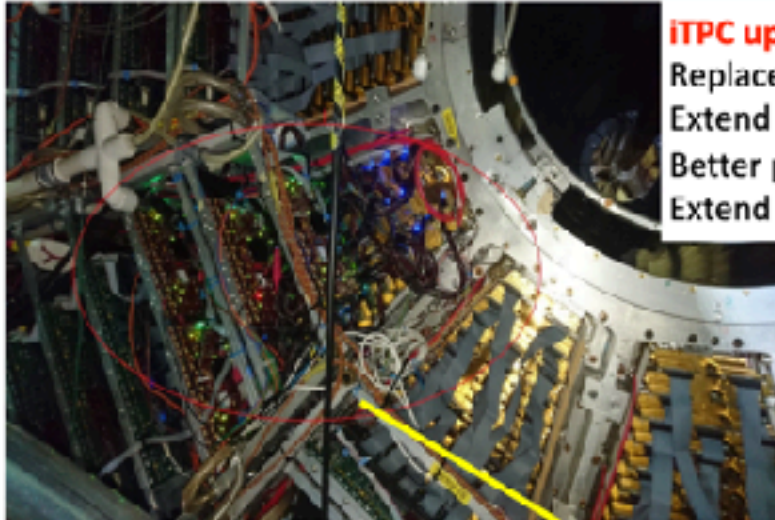

iTPC upgrade (2018)
 Replace inner TPC Sectors
 Extend rapidity coverage
 Better particle ID
 Extend low p_T coverage

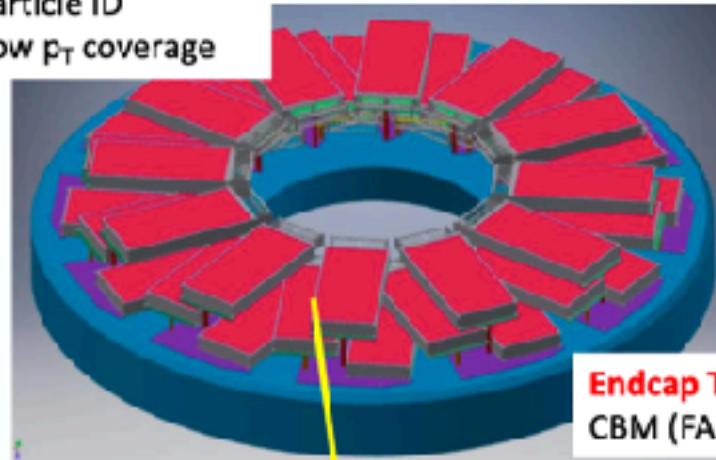

**Endcap TOF
 CBM (FAIR)**

Event Plane Detector
 Improved Event Plane Resolution
 Centrality definition
 Improved trigger

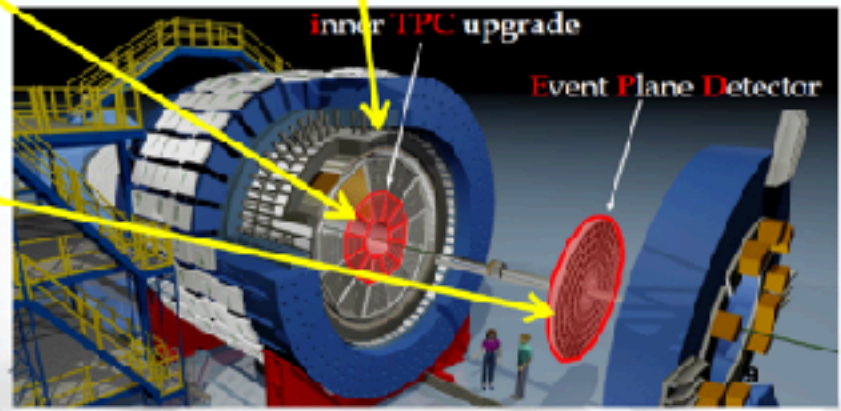
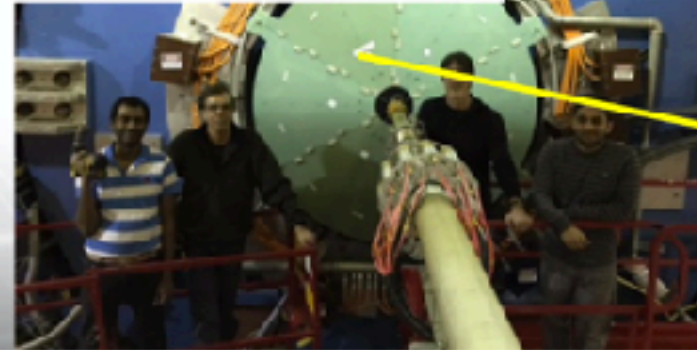

inner TPC upgrade

Event Plane Detector

BES-II approaching completion

Much higher statistics than BES-I
(Factor 10 or more)

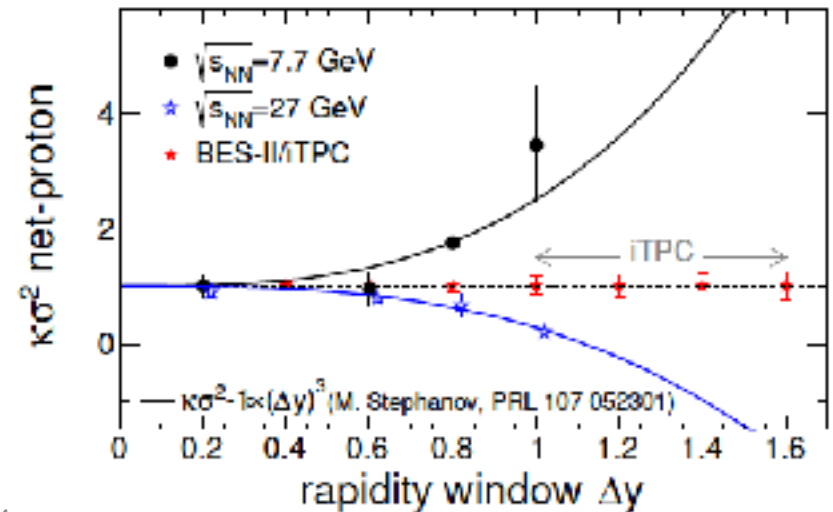
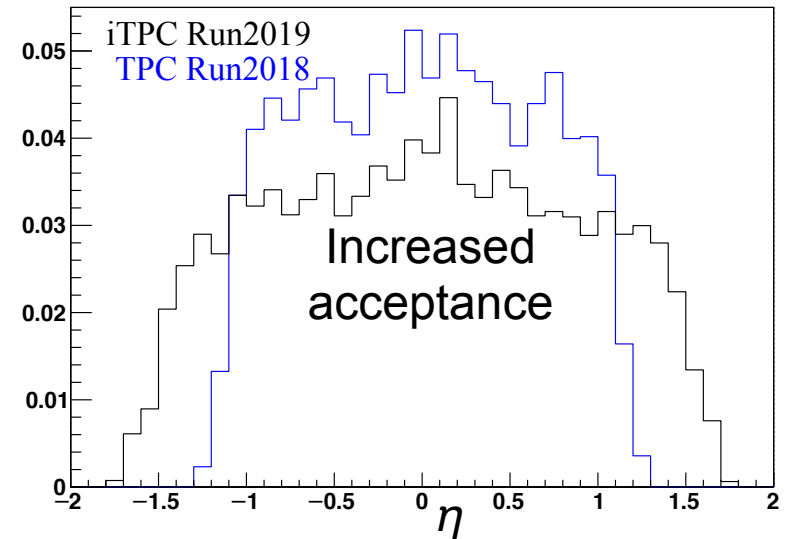
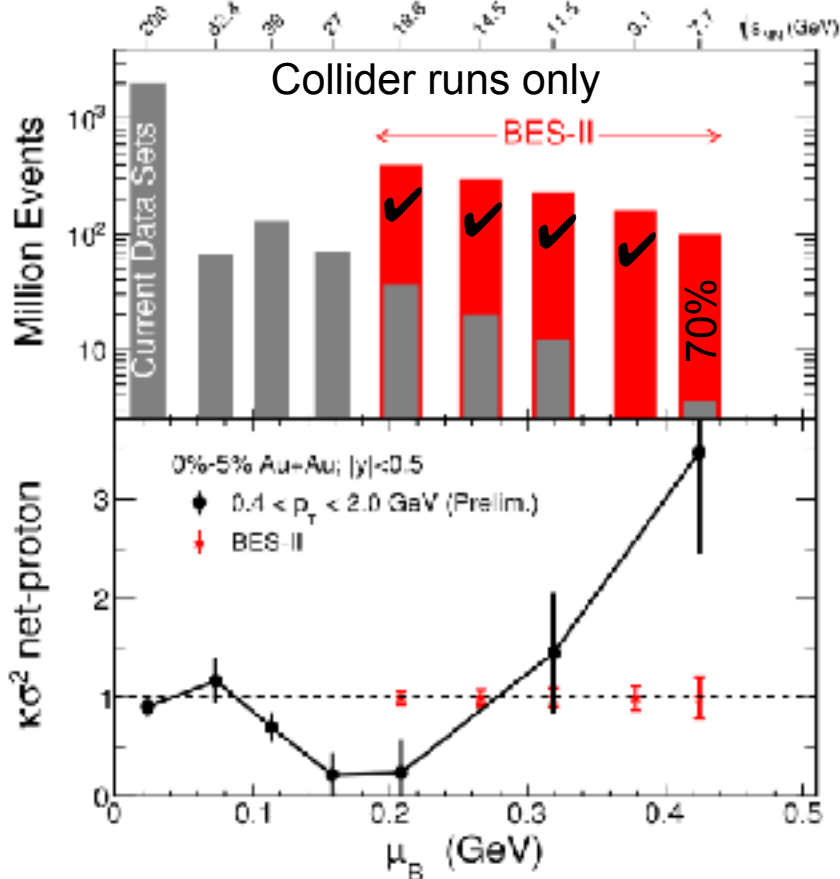

LEReC and iTPC Acceptance

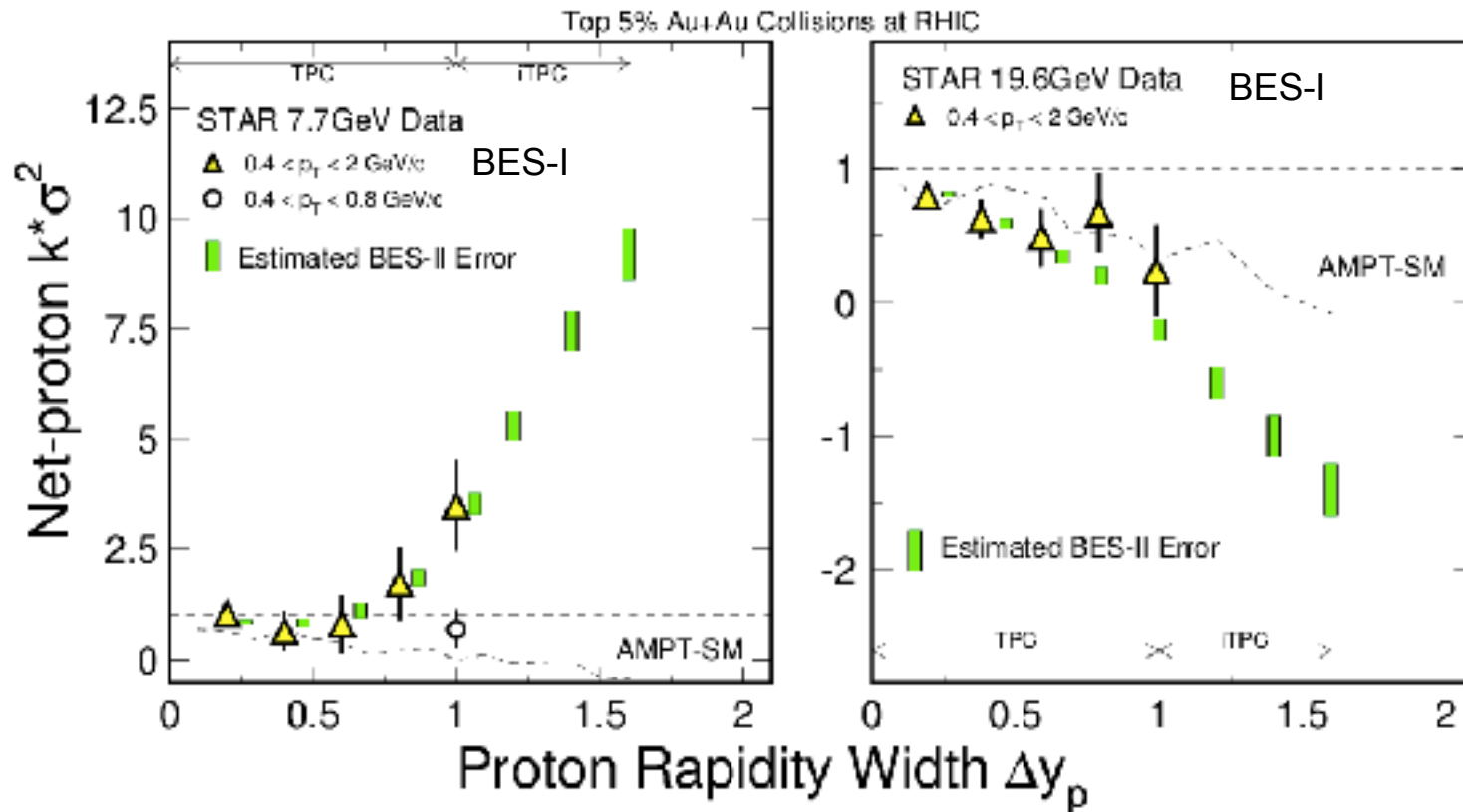

Kurtosis (fourth-order fluctuations) signal grows like $(\Delta y)^3$
 → **Detector coverage is critical for a definitive measurement**

Increased luminosity reduces error bars

Critical Point Search

Critical behavior signals

The moments of the distributions of baryon number are related to critical susceptibilities and sensitive to critical fluctuations

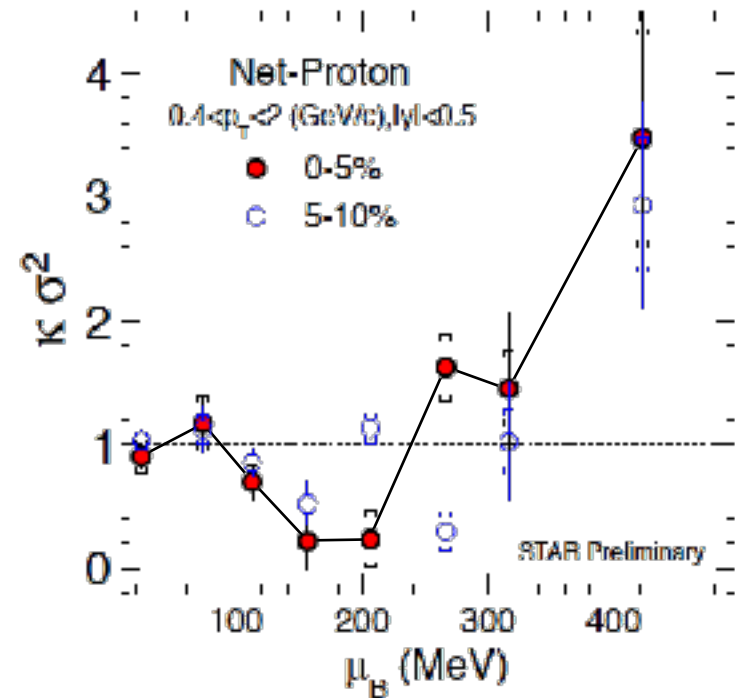
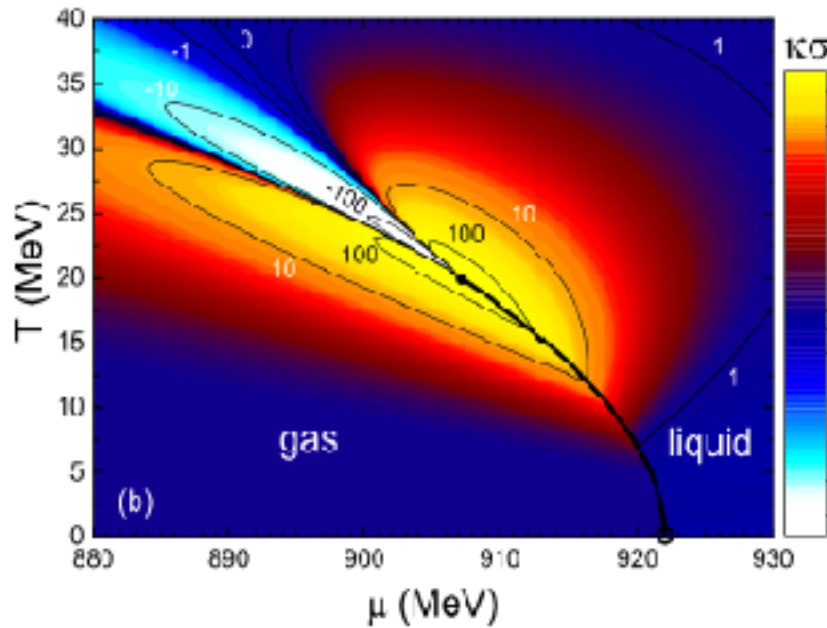

Higher moments (kurtosis) change sign at the critical point

Non-monotonic trend observed in BES-I with limited statistical precision

Critical signature: Net-proton kurtosis

Net-baryon/proton density of the QGP is controlled by the collision energy

Near the critical point, the correlation length of fluctuations diverges and the kurtosis ($\kappa-1$) of the net-proton distribution changes sign

Expected behavior near critical point

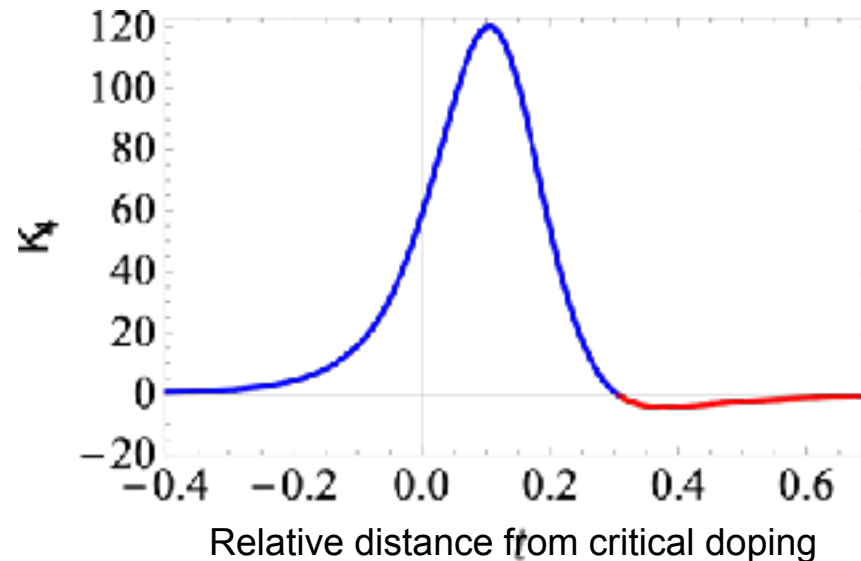

BES I provided a tantalizing hint, but with insufficient precision

Critical point search challenges I

- During the collision, the matter samples a rather large range of μ_B and T , not just a narrow path that can be tuned to hit the critical point by choosing the right collision energy.
- The expanding matter is always out of equilibrium. By how much depends on the ratio of the equilibration time τ_{eq} to the characteristic expansion time τ_{exp} . At the critical point, τ_{eq} for the critical mode diverges (critical slowing down): correlation length is controlled by interplay between diffusion and expansion dynamics (KZ regime).
- This is both, a boon and a curse: The effect of critical fluctuations is suppressed, but they may also remain frozen in to some degree as the matter moves away from the critical point.
- At lower collision energies, there is no central rapidity “plateau”, and the net baryon density varies significantly over the pseudorapidity window covered by the detector ($\Delta\eta \approx 3$). Thermal smearing implies that much smaller $\delta\eta$ windows come with loss of signal strength.

Critical point search challenges II

- Dynamical modeling of heavy ion collisions at lower collision energies is much more challenging and model dependent:
 - Baryon number fluctuations are sensitive to fluctuations of poorly understood baryon stopping.
 - Hydrodynamics needs to include transport of conserved quantum numbers (B, Q, S) and dynamics of correlations.
 - Colliding nuclei are less Lorentz contracted, and thus initial energy / baryon number deposition is not cleanly separated from transport.
 - μ_B dependence of transport coefficients is unknown, not calculable on the lattice, and difficult to deduce from data.
- Research by BEST collaboration is an essential contribution to tackling these formidable challenges. Progress is being made.

Critical Point Challenges III

Finally some issues that are sometimes overlooked [M. Asakawa, M. Kitazawa, BM, *Phys. Rev. C* 101 (2020) 034913]:

- Fluctuations of conserved quantities, such as net baryon number do not freeze out at T_{ch} but at T_{kin} , because they change due to diffusion. T_{kin} is reached deep in the hadronic phase, requiring an appropriate transport framework.
- The equilibrium relation $K_n \sim \xi^n$ does not hold away from equilibrium. Because the order parameter is related to a conserved quantity, its dynamics becomes enslaved to diffusive processes.
- Fluctuations and correlations occur in coordinate space, but are measured in momentum space. The mapping between the two is not simple due to thermal smearing, and the usual boost-invariant mapping is not valid at BES energies. Long-distance, low-relative momentum correlations among particles compete with HBT correlations.

Hunting the Critical Point I

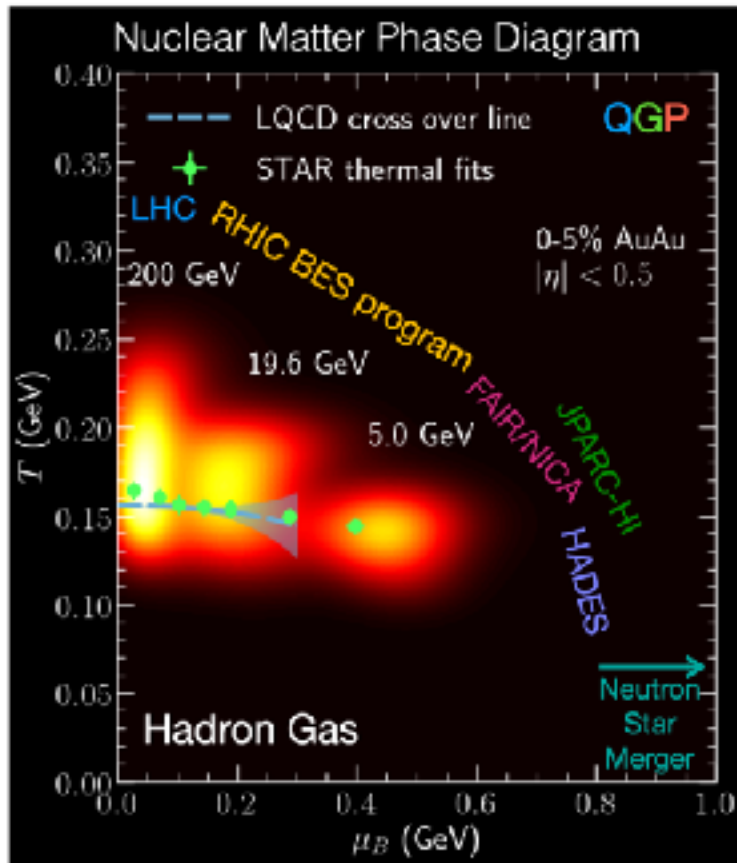

From C. Shen, L. Yan, 2010.12377

RFD calculation in T - μ space:

- 3+1D ideal RFD: Au+Au @ GeV/u
- realistic EoS with Critical Point
- color map reflects # of cells at each value of (T, μ)
- ▶ collision evolution probes rather broad range of (T, μ) values along temporal trajectory of reaction!

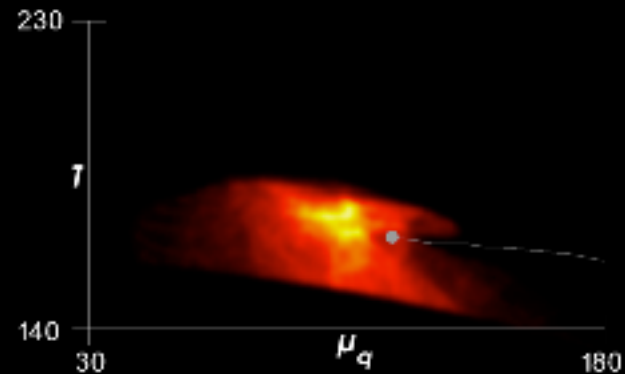

Courtesy: H. Petersen (2012)
MADAI collaboration

Hunting the Critical Point II

Visualizing RFD “trajectory” in T - μ space

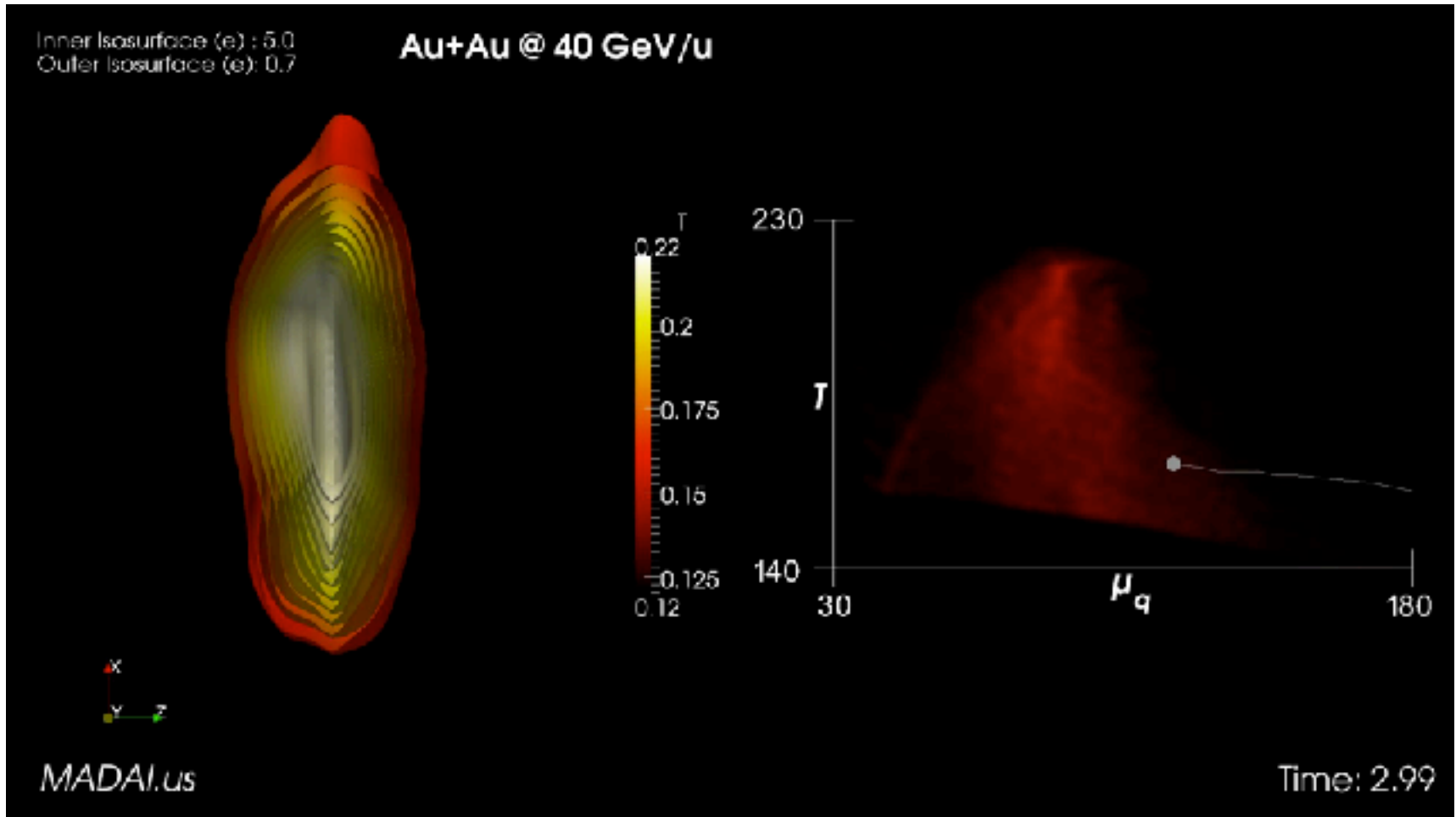

EOS & KZ regime

Phenomenological equation of state of QCD at finite baryon density with baryon number, electrical charge, and strangeness conservation

(e) NEOS BQS

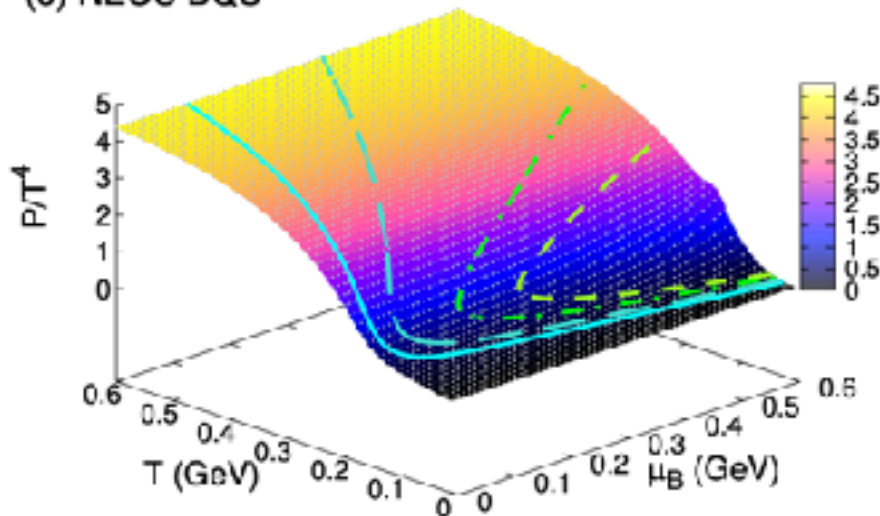

A. Monnai, B. Schenke, C. Shen,
IJMP A 36 (2021) 2130007

S. Mukherjee, R. Venugopalan, Yi Yin,
PRL 117 (2016) 222301

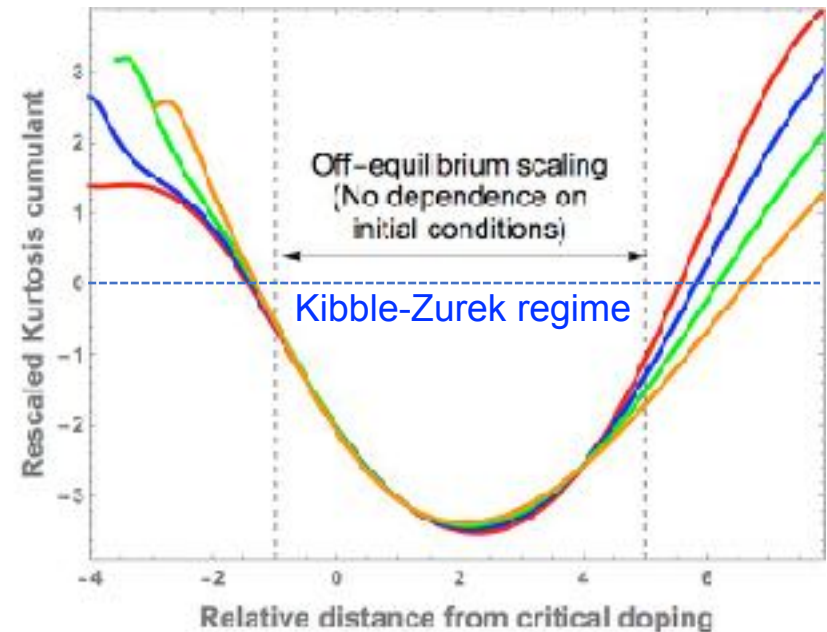

Off-equilibrium scaling of critical cumulants is scaling universally (Kibble-Zurek scaling)

Non-equilibrium fluctuations

Very nice parametric study by Y. Akamatsu, D. Yeane, F. Yan, and Yi Yin, of non-equilibrium fluctuations when the matter passes near the Critical Point [*Phys. Rev. D* 100 (2019) 044901]. For $\lambda = \tau_{\text{eq}}/\tau_{\text{exp}} = 0.2$ the maximal critical enhancement of correlations is $\sim 80\%$ and show up for $\Delta p \lesssim 1/\ell_{\text{kz}} \approx 50$ MeV.

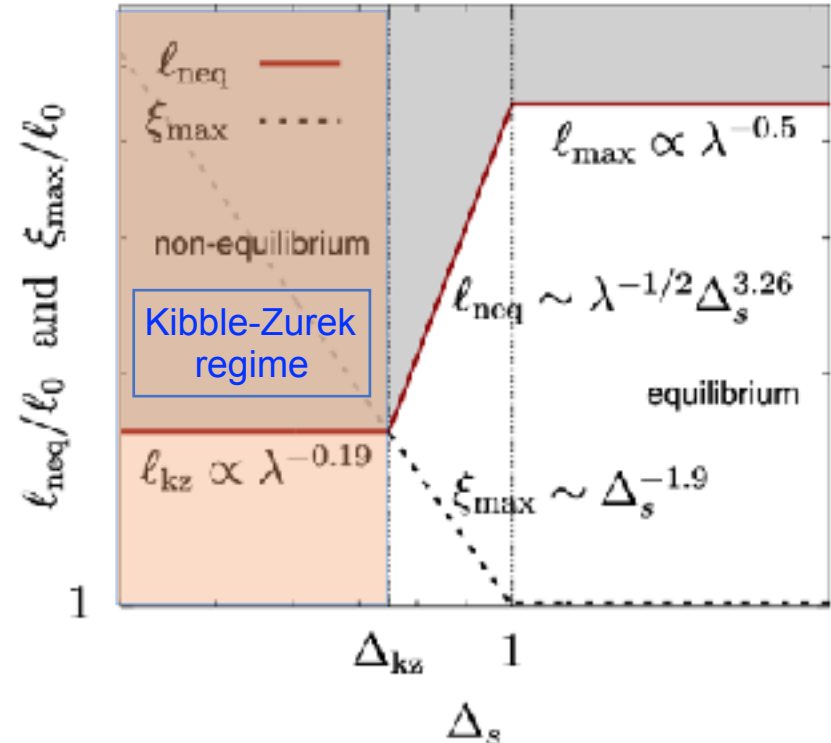
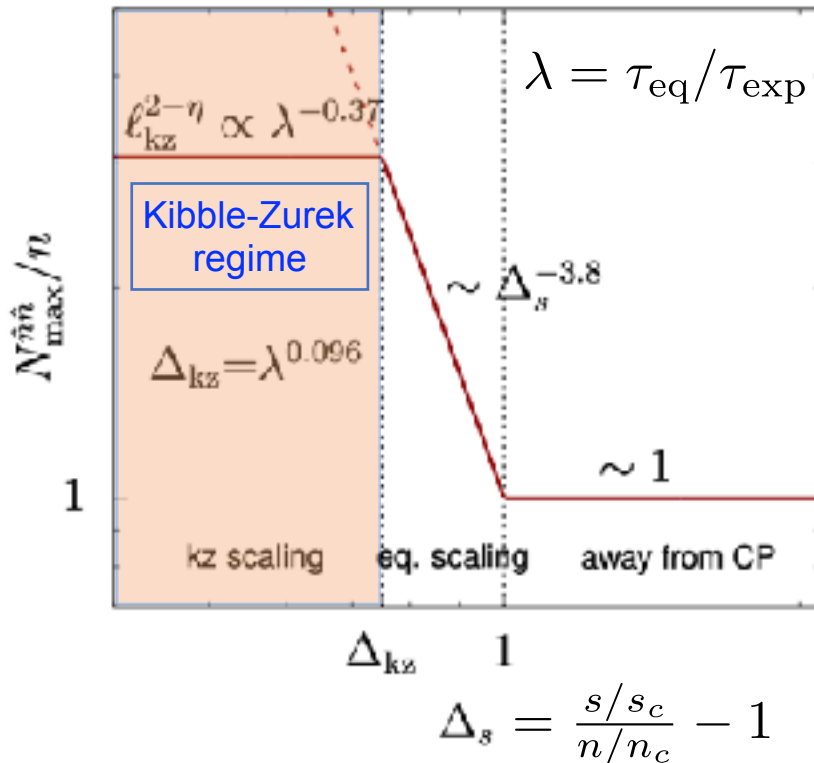

Beyond the BES-II: STAR+ and sPHENIX

STAR & sPHENIX Upgrades

New STAR forward detector systems in construction for FY 2022 RHIC run will enable measurements of physics important for EIC science program:
 Universality of 3-D parton dynamics

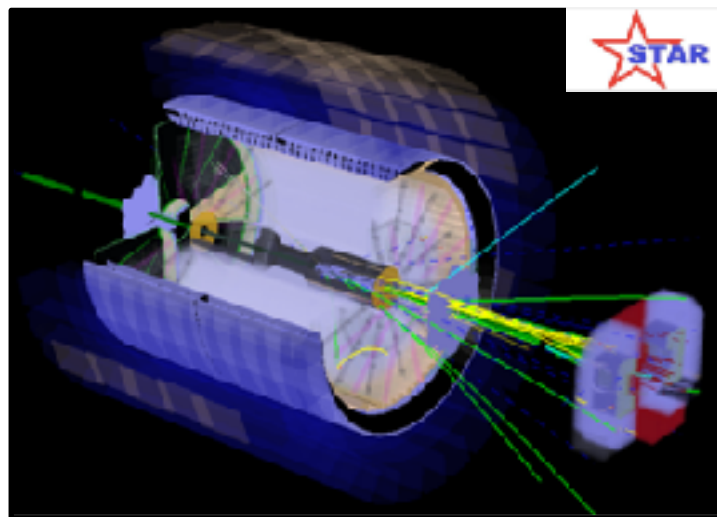

- High energy jets probe the structure of the QGP on different length scales and determine where and how it changes from particle-like quarks and gluons to a structureless “perfect” liquid
- Heavy quark atoms (Upsilon) also probe the QGP structure at different scales
- State-of-the-art collider detector using technology developed for LHC by ONP and OHEP

Data taking scheduled for 2023–2025
 sPHENIX will fully utilize the enhanced (50 times design) luminosity of RHIC

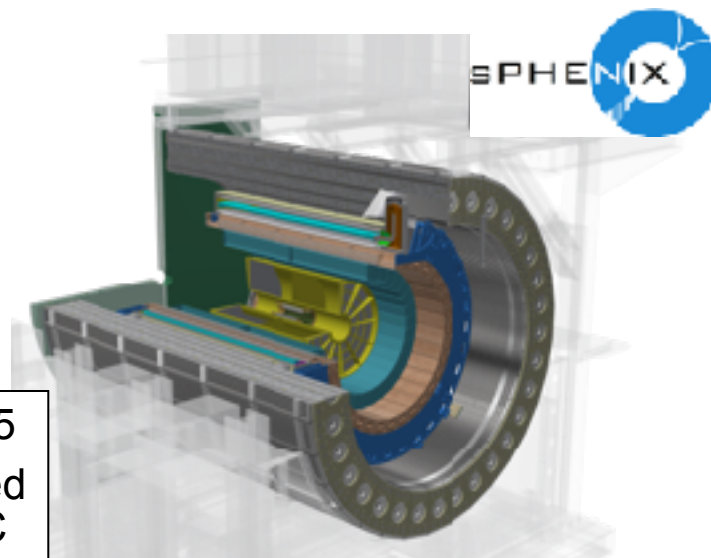

RHIC Program: Forward Physics

- STAR collaboration is implementing forward upgrades for RHIC runs beyond BES-II with significant international (esp. Chinese) and other non-DOE contributions. Upgrade to be ready for 2022 RHIC run.
- Physics program described in 2016 RHIC Cold QCD Plan - similar, but complementary to measurements planned for EIC.

Refurbished EMCal, new Hcal, STAR Pre-shower, FMS, and sTGC based tracking system, covering $2.5 < \eta < 4$, forward Si tracking.

Enables a polarized 500 GeV proton run in 2022 and continued running in parallel to sPHENIX

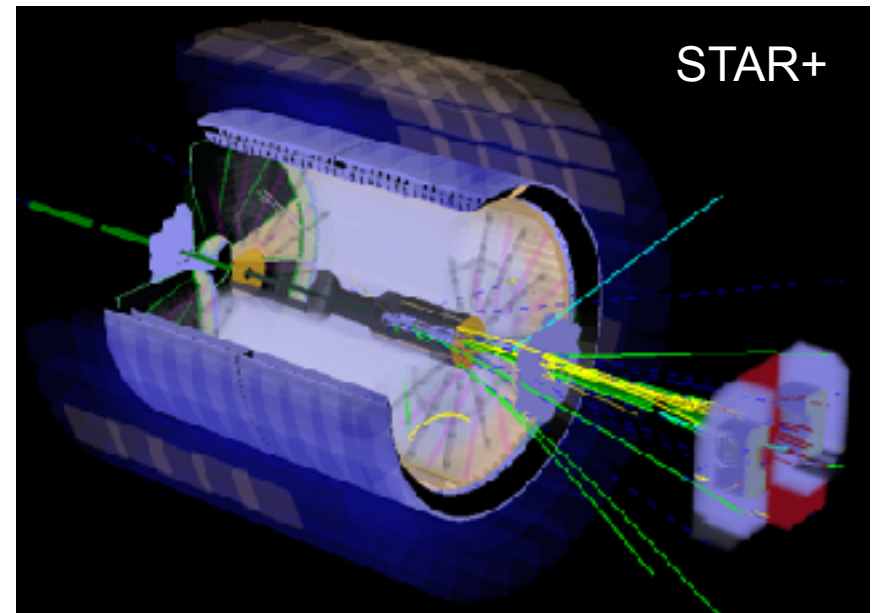

Cold QCD @ STAR

Mid-rapidity $-1.5 < \eta < 1.5$

Forward-rapidity $2.8 < \eta < 4.2$

p+p & p+A

Beam:

500 GeV: p+p

200 GeV: p+p and p+A

Physics Topics:

- Improve statistical precision
 - ▶ TMD measurements (Collins, Sivers)
 - ▶ Access s & Δs through Kaons in jets
- Measurement of GPD E_g through UPC J/ψ
- First access to Wigner functions through di-jets in UPC
- Gluon and quark vacuum fragmentation
- Gluon and quark fragmentation in nuclear medium
- Nuclear dependence of Collins FF

Rich physics program ::

p+p & p+A

Beam:

500 GeV: p+p

200 GeV: p+p and p+A

- TMD measurements at high x transversity \rightarrow tensor charge
- Improve statistical precision for Sivers through DY
- $\Delta g(x, Q^2)$ at low x through Di-jets
- Gluon PDFs for nuclei
 - ▶ R_{pA} for direct photons & DY
- Test of Saturation predictions through di-hadrons, γ -Jets

sPHENIX Layout

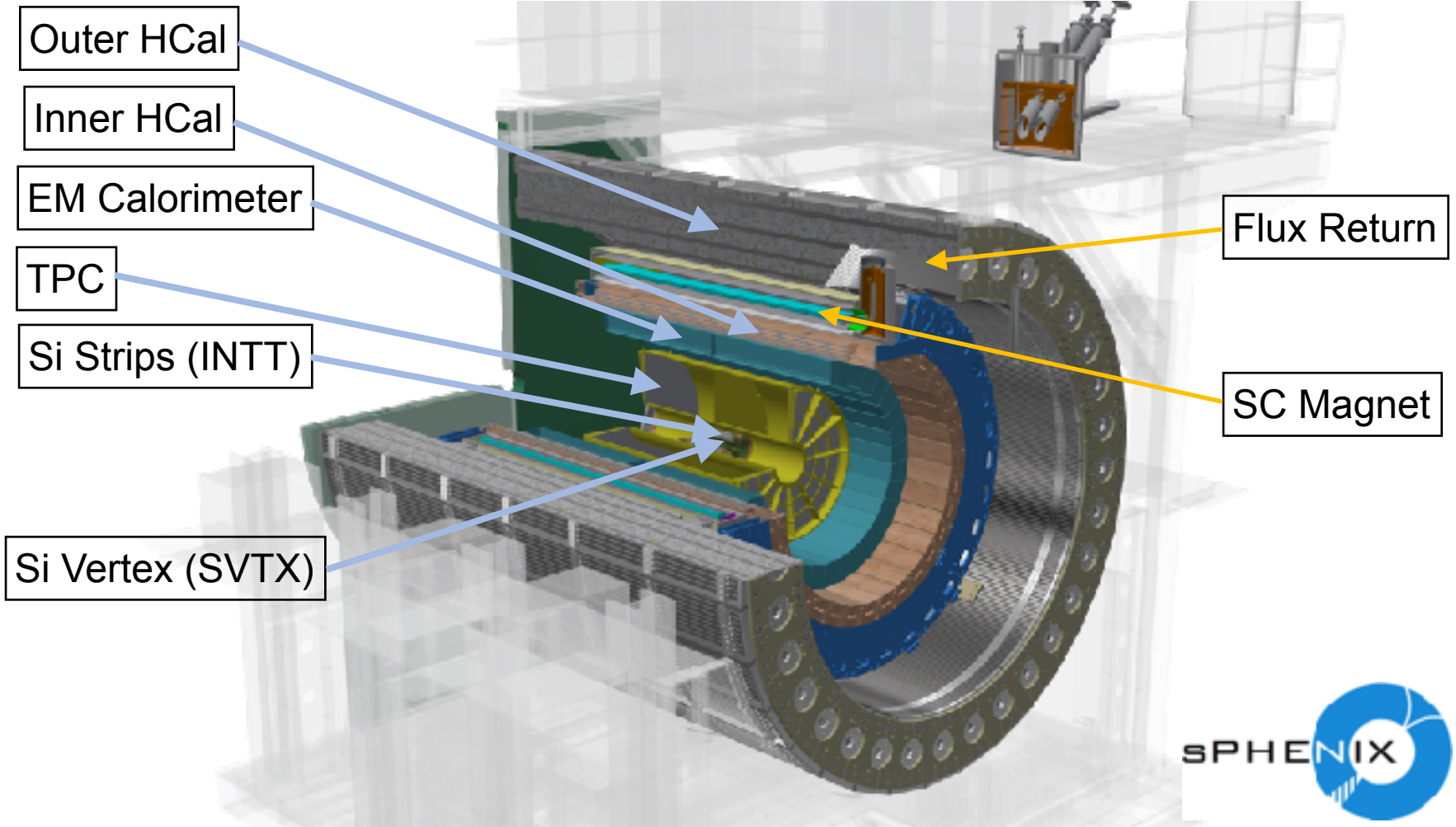

sPHENIX

- State-of-the-art collider detector incorporating technology developed for LHC by NP and HEP
- Components complete end of 2021
- Assembly complete end of 2022
- Data taking to start in 2023

Expanding jets probe various distance scales

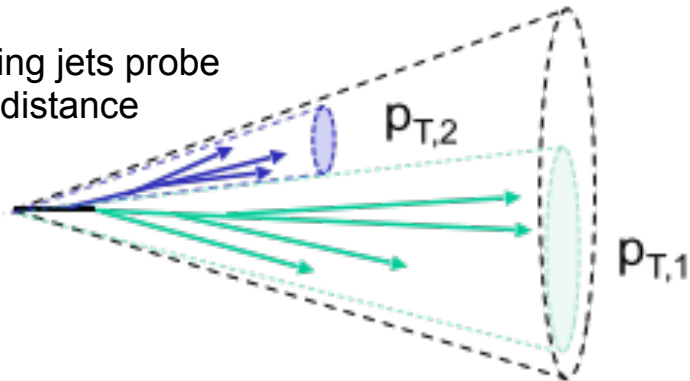

Upsilon states probe QGP structure

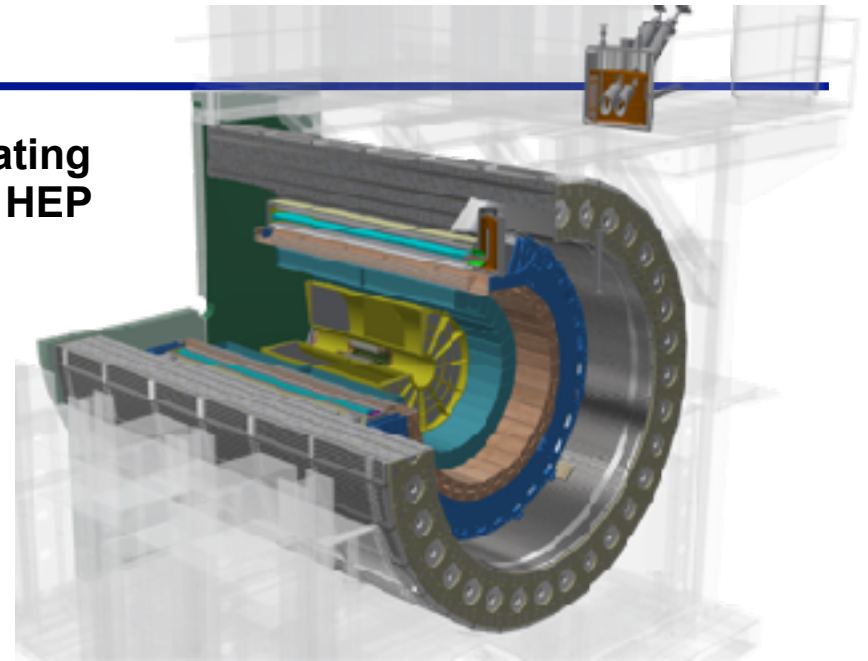
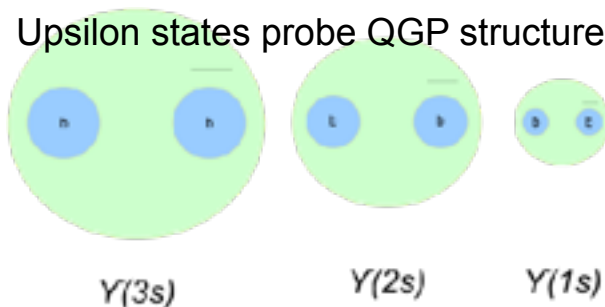

- High energy jets probe the structure of the QGP on different length scales
- Heavy quark atoms (Upsilon) also probe the QGP structure at different scales
- Heavy flavor hadrons and jets probe the transport properties of the QGP

sPHENIX will increase the data collection rate by a factor of 10 and utilize the enhanced RHIC luminosity

sPHENIX physics reach

Jet spectroscopy
with full calorimetry
and Si+TPC tracking

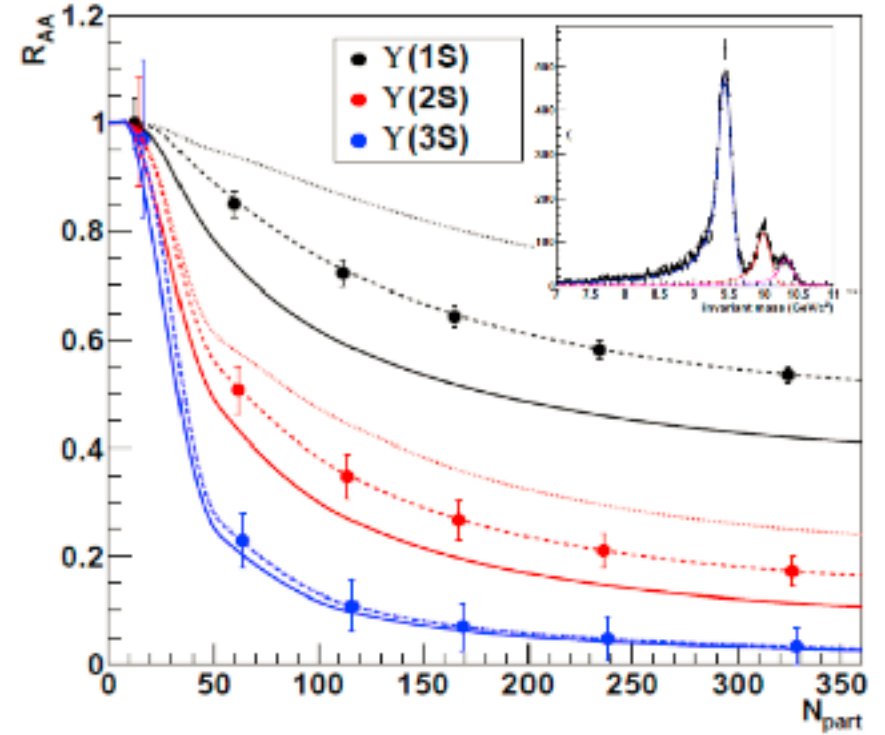
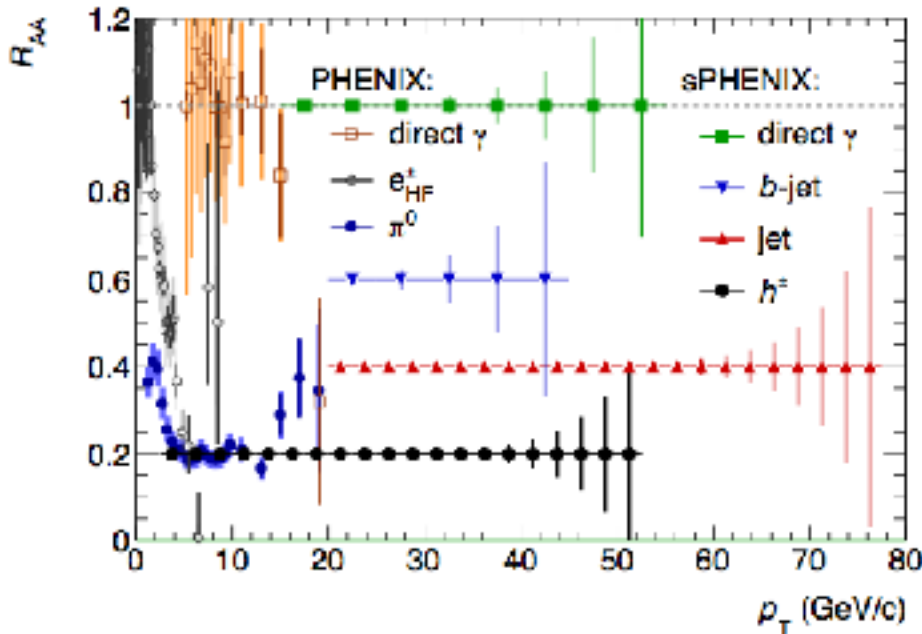

Completely resolved
Upsilon spectroscopy
SVTX+INTT+TPC+EMCal

Jets Probe QCD Structure

Parton virtuality evolves quickly
Sensitive to the medium at the scale it probes

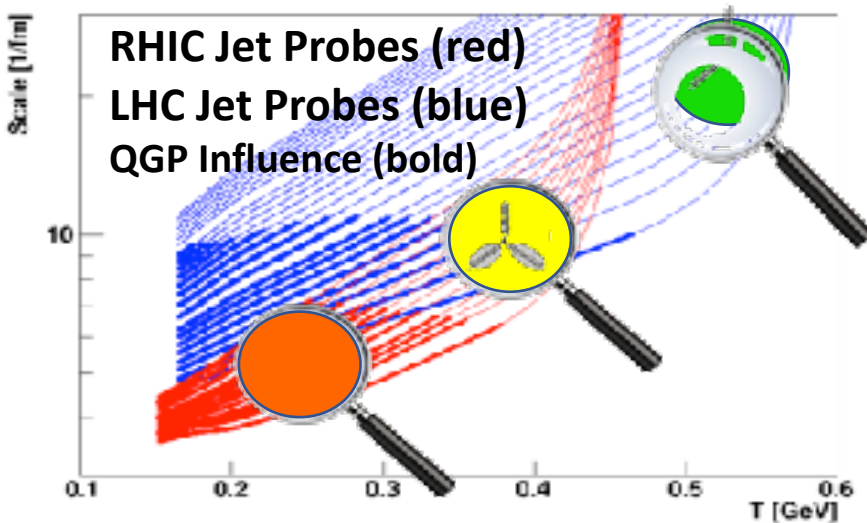

Different kinematic jet scale and energy at RHIC and LHC provides complementary sensitivity

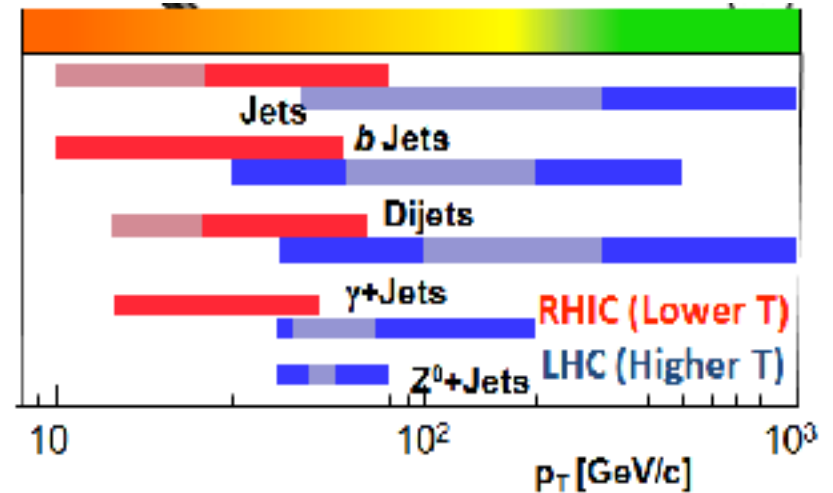
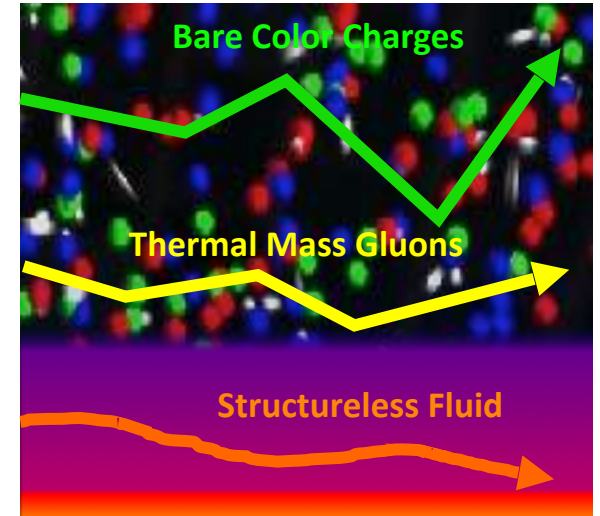

The RHIC Facility in 2023-25

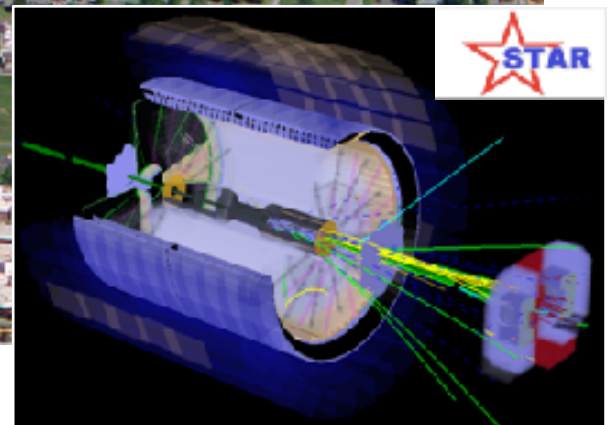
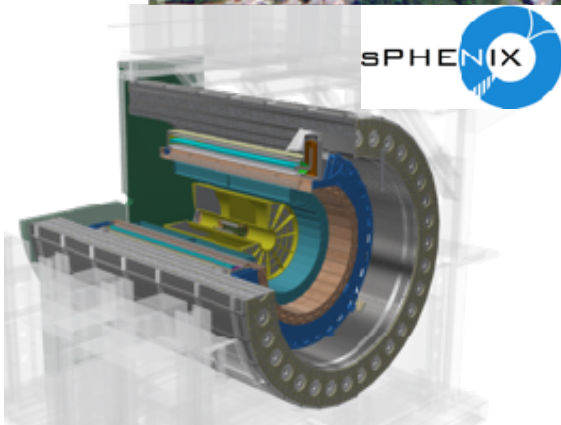
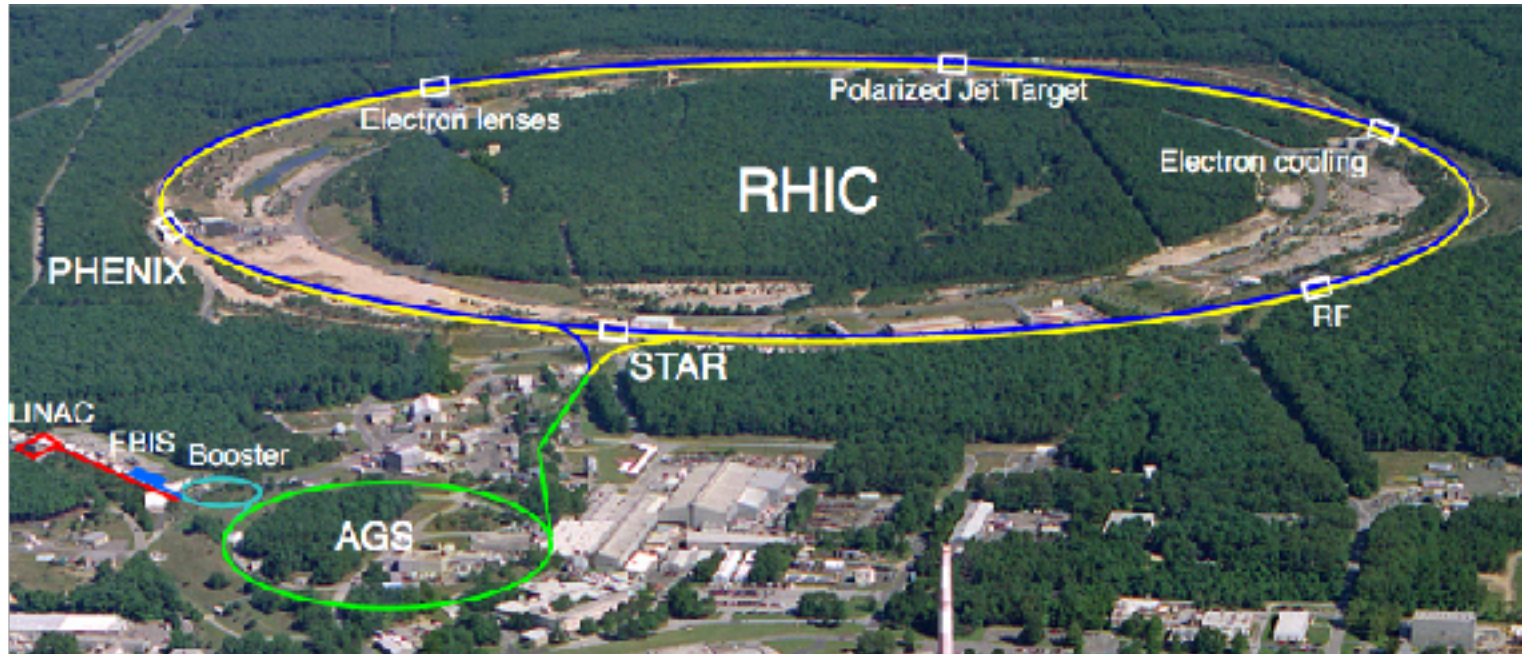

RHIC Run Plans

❖ **Beam Energy Scan II (2019-21):**

- ❖ Low energy ($\sqrt{s_{NN}} = 7.7, 9.1, 11.5, 14.5, 19.6$ GeV) Au+Au runs
- ❖ Fixed target runs at (3.0), 3.5, 3.9, 4.5, 5.2, 6.2, 7.7 GeV
- ❖ Search for signs of critical phenomena in event-by-event fluctuations

❖ **Forward spin run (2022):**

- ❖ 500 GeV p+p (enhanced by forward upgrades of STAR)
- ❖ Spin physics measurements complementary to EIC

❖ **Runs with sPHENIX and STAR+ (2023-25):**

- ❖ Full energy ($\sqrt{s_{NN}} = 200$ GeV) Au+Au, p+p, p+Au
- ❖ Precision measurements of fully resolved jets, Upsilon states, heavy flavor
- ❖ STAR taking “legacy data” with iTPC, forward detectors

“What RHIC Will Deliver” (2015 LRP)

- **Campaign 1 (2014-17):**

- ✓ QCD equation of state at $\mu_B \approx 0$
- ✓ Precision measurement of $\eta/s(T \approx T_c)$
- ✓ Measurement of heavy quark diffusion constant $D_{c/b}$
- ✓ Measurement of x-dependence of nuclear granularity
- ✓ Origin of single spin asymmetries
- ✓ ΔG , flavor dependence of spin in the quark sea
- ✓ QGP vorticity [not anticipated in 2015]

- **Campaign 2 (2018-20):**

- Chiral symmetry restoration via CME
- QCD equation of state at $\mu_B > 0$
- Discovery of the QCD critical point, if within the accessible range

- **Campaign 3 (2022++):**

- Precision measurement of jet quenching parameters
- Determine length scale where the QGP becomes a liquid
- Cold QCD measurements essential for EIC physics

The RICH Opportunities of RHIC

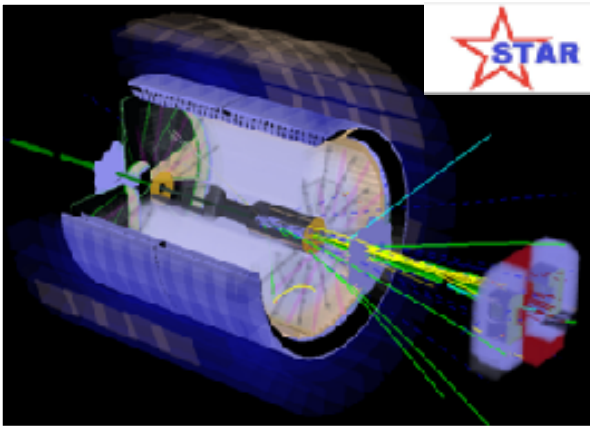

STAR

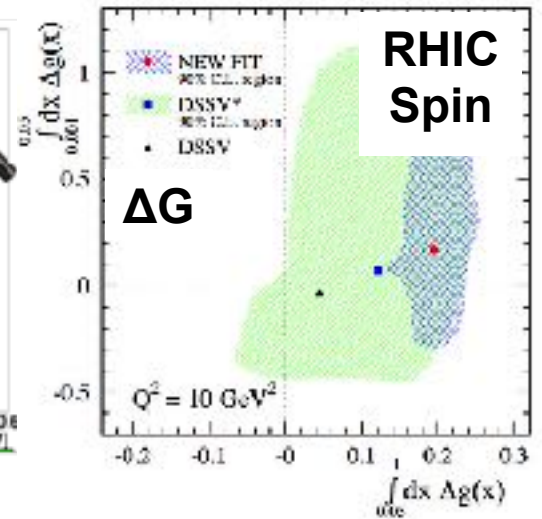
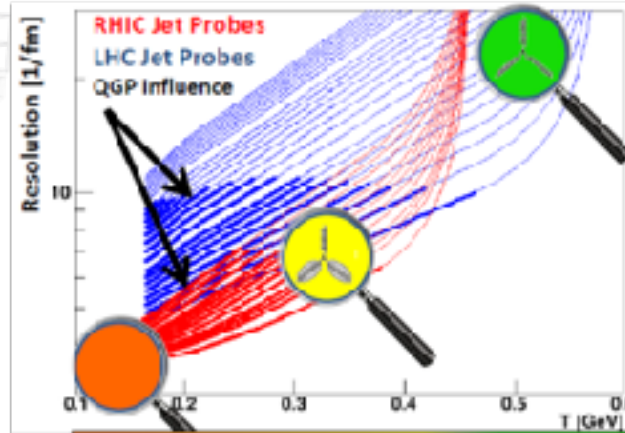
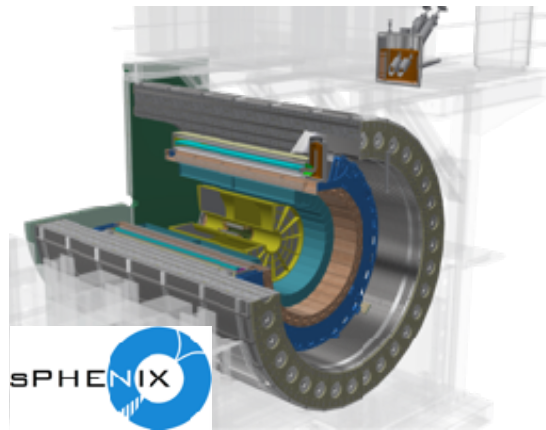
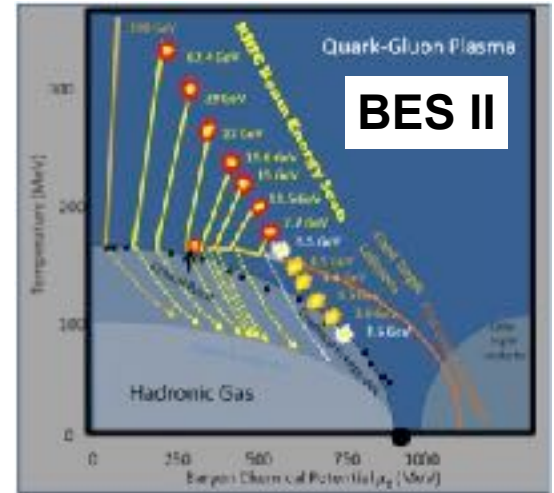
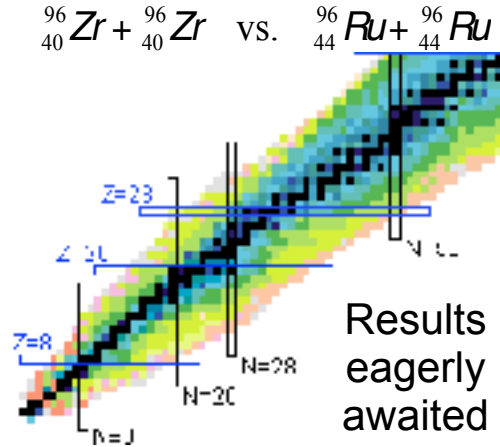

THANK YOU
for your attention!

Questions?